

# BYTE<sup>®</sup>

September 1982 Vol. 7, No. 9  
\$2.95 in USA  
\$3.50 in Canada/£1.85 in U.K.  
A McGraw-Hill Publication

the small systems journal

SEPTEMBER 1982

BYTE

COMPUTERS AND THE DISABLED

Volume 7, Number 9



ROBERT  
& WINNEY

**Computers and the Disabled**

# Powerful.



DPU card with error-correcting memory and controller cards

## 68000-Powered for tomorrow

Once again you get a big stride forward with Cromemco.

This time it's our new DPU Dual Processor Unit. It gives enormous power to Cromemco computer systems such as our System One shown here.

### Compares with mainframes

With the new DPU you get the almost unbelievably powerful 68000 processor and its 32-bit data-handling capabilities combined with its **16 Megabyte** address space.

In other words with the System One/DPU combination you get a small machine that's the equal of superminis and mainframes in some areas.

### 8-Bit and 68000 software

The dual part of the DPU refers to its on-board Z-80A processor. With this you have access to existing CP/M\* software.

But besides being compatible with this wealth of existing 8-bit software, the System One/DPU has available a whole family of new 68000 system software. This includes a wide range of high-level software such as our 68000 Assembler, FORTRAN 77, Pascal, BASIC, COBOL, and C.

Beyond all this there's a version for the 68000 of our widely admired CROMIX† Operating System. It's like UNIX‡ but has even more features and gives multi-tasking and multi-user capability. In fact, one or more users can run on the Z-80A processor while others are running on the 68000. Switching between the Z-80A and 68000 is automatically controlled.

The System One itself is a bus-oriented machine that has options for color graphics, for 390K or 780K of floppy storage, a 5 MB hard disk option, communications capability, and multi-processor capability using our I/O processor card.

# Powerful new micro. Powerful software.



System One CS-1H



3102 Terminal

## Highly expandable

With the System One/DPU combination, you get tremendous expandability. Right now you can have up to 2 MB of RAM storage. You get this with our new Memory Storage cards and our Memory Controller. The Controller fully supports the 16 MB storage space of the 68000, allowing you vast future expansion capability.

Further, the memory has built-in **error detection and correction**, a feature normally found only in much more costly systems.

Present customers can field-upgrade their Cromemco systems to use the DPU and still be able to run their present software using the Z-80A on the DPU. It's one more

instance of Cromemco's policy of providing obsolescence insurance for Cromemco users.

## Low priced

With all this performance you might not be ready for the low price we're talking about. With 256K of RAM and 780K of floppy storage, the price of the System One/DPU is only \$5495. That's hard to beat.

So contact your rep now. He'll fill you in on the many more features that this outstanding and powerful machine offers.

\*CP/M is a trademark of Digital Research  
†CROMIX is a trademark of Cromemco, Inc.  
‡UNIX is a trademark of Bell Telephone Laboratories



**Cromemco**<sup>TM</sup>  
I n c o r p o r a t e d

280 BERNARDO AVE., MOUNTAIN VIEW, CA 94040 • (415) 964-7400  
Tomorrow's computers today

Circle 137 on Inquiry card.

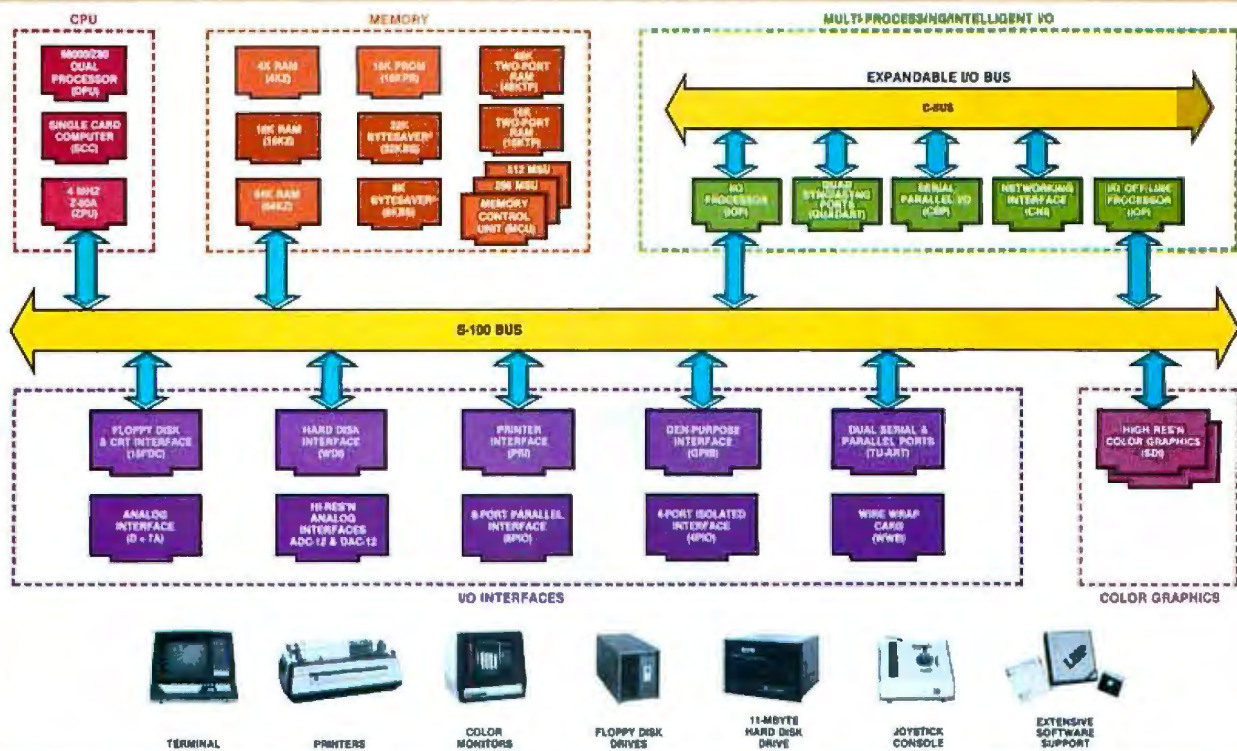

# What Cromemco computer card capability can do for you

The above diagram shows in a functional way one of the most complete lines of computer cards in the industry.

Look it over carefully. It could be well worth your while.

These are all cards that plug into our S-100 bus microcomputers.

You can also assemble them into a custom system in convenient Cromemco card cages.

## MULTI-PROCESSING AND INTELLIGENT I/O

The range of capabilities and versatility you can draw upon is enormous.

In processors, for example, you have a choice of CPU's including our extremely useful new I/O Processor. This can be used as a satellite processor to do off-line processing, multi-processing, and to form intelligent I/O. It opens the door to a whole new group of applications and tasks. Ask us about it.

## HIGH RESOLUTION COLOR GRAPHICS

Again, you can have beautiful high-resolution color graphics with our color graphics interface. You can select from over 4000 colors and have a picture with a resolution at least equal to quality broadcast-TV pictures.



You have an unprecedented selection of memory including our unusual 48K and 16K two-port RAMs which allow high-speed color graphics.

## LOTS OF STORAGE

These days you often want lots of disk storage. So you can select from our disk controller card which will operate our 5" and 8" floppy disk drives (up to 1.2 megabytes). Or select our WDI interface to operate our 11-megabyte hard disk drives.

## POWERFUL SOFTWARE AND PERIPHERAL SUPPORT

There's much more yet you can do with our cards. And, of course, there's an easy way to put them to work in our 8-, 12-, and 21-slot card cages. Our PSB power supply makes it simple to get the system into operation.

Finally, Cromemco offers you the strongest software support in the industry

with languages like FORTRAN, C, COBOL, ASSEMBLER, LISP, BASIC and others. There is also a wide choice from independent vendors.

To top it all off, you can draw from a substantial array of peripherals: terminals, printers, color monitors and disk drives.

There is even more capability than we're able to describe here.

## NOW AT HALL-MARK AND KIERULFF

For your convenience Cromemco products are now available at Hall-Mark Electronics and Kierulff Electronics. Contact these national distributors for immediate product delivery.

### CROMEMCO COMPUTER CARDS

- PROCESSORS — 4 MHz Z-80 A CPU, single card computer, I/O processor
- MEMORY — up to 64K including special 48K and 16K two-port RAMs and our very well known BYTESAVERS® with PROM programming capability
- HIGH RESOLUTION COLOR GRAPHICS — our SDI offers up to 754 x 482 pixel resolution.
- GENERAL PURPOSE INTERFACES—QUADART four-channel serial communications, TU-ART two-channel parallel and two-channel serial, 8PIO 8-port parallel, 4PIO 4-port isolated parallel, D+7A 7-channel D/A and A/D converter, printer interface, floppy disk controller with RS-232 interface and system diagnostics, wire-wrap and extender cards for your development work.



**Cromemco**™  
Incorporated

280 BERNARDO AVE., MOUNTAIN VIEW, CA 94040 • (415) 954-7400

Tomorrow's computers today

Circle 138 on Inquiry card.

# In The Queue

**BYTE**

Volume 7, Number 9

September 1982

## Features

**24 Quintl-Maze** by Robert Tsuk / A three-dimensional game that may redefine for you the meaning of "lost." It placed eighth in the BYTE Game Contest.

**34 Three Dee Tee** by John Stuart / Strategy is the key word in this game designed for the TRS-80 Color Computer. It's the seventh-place winner in the BYTE Game Contest.

**54 The Epson QX-10/Valdocs System** by Gregg Williams / This new machine from Epson combines a word processor, an appointment book, an electronic mail network, and more in one package—all for less than \$3000.

**58 NCC Report** by Chris Morgan / New products from the United States and Japan put the spotlight on microcomputers at the National Computer Conference.

**62 The Hanover Fair** by Robert E. Ramsdell / The annual exposition is a showcase for the latest microcomputers and data-processing and office equipment.

**64 Build the Microvox Text-to-Speech Synthesizer** by Steve Garcia / The 6502 microprocessor in this intelligent peripheral device translates plain English text into phonemes to control a Votrax SC-01A.

**136 Computers Can Play a Dual Role for Disabled Individuals** by Gregg Vanderheiden / Microcomputers must be made to do more than help disabled individuals in specialized ways; they must be adapted to give the disabled access to standard software.

**166 A New Horizon for Nonvocal Communication Devices** by Patrick Demasco and Richard Foulds / The Panasonic Hand-Held Computer can be used as a personal, portable speech prosthesis.

**186 Minspeak** by Bruce Baker / A picture can truly be worth a thousand words for people using this speech synthesizer.

**204 The FDA Regulation of Computerized Medical Devices** by Joseph Jorgens III, Carl W. Bruch, and Frank Houston / What you need to know before your creation hits the market.

**218 Talking Terminals** by David Stoffel / New devices open the world of computing to people with visual impairments.

**250 Braille Writing in Pascal** by Alfred Fant Jr. / A Pascal program, a strip of cellophane tape, and a rubber glove combine to make a line printer for braille text.

**276 Adaptive-Firmware Card for the Apple II** by Paul Schwejda and Gregg Vanderheiden / Physically disabled individuals can control standard programs without permanent modifications to the computer.

**318 User's Column: Letters, Pascal, CB/80, and Cardfile** by Jerry Pournelle / One man's opinion on a variety of subjects of interest to computer users.

**342 Logo: An Approach to Educating Disabled Children** by Sylvia Weir, Susan Jo Russell, and José A. Valente / Creating action-oriented learning environments and putting pupils in charge of their own learning greatly benefits students with severe educational disabilities.

**398 Model III A to D Revisited** by William Barden Jr. / Build this simple and inexpensive analog-to-digital converter.

**420 The Case of the Purlined Object Code: Can It Be Solved? Part 1: The Problems** by Richard H. Stern / A specialist in software and the legal aspects of high technology explains why new laws are necessary.

**440 A Comparison of Five Compilers for Apple BASIC** by Joseph H. Taylor and Jeffrey S. Taylor / Speed isn't the only factor to assess when choosing a compiler.

**466 Digital Troubleshooting with Signature Analysis** by Steven A. Piubeni / A look inside Hewlett-Packard's HP-5004A.

**476 Program Your Own Text Editor, Part 1: Avoid Complex Commands by Using Instant Updating** by Richard Fobes / A commonly used program should be easy to work with.

**513 A Weaving Simulator** by Paul W. Heiser / The final appearance of a loom pattern can be predicted with a microcomputer and a printer.

**520 Turn Your Apple II Into a Storage Oscilloscope** by Larry Korba / Low-repetition transient pulses can be easy to capture.

## Reviews

**92 The Apple III and Its New Profile** by Robin Moore

**231 The Cognivox VIO-1003: Voice Recognition and Output for the Apple II** by Dr. William Murray

**240 The Abilityphone** by William L. Rush

**362 BYTE's Arcade: Swashbuckler** by Scott Spangenberg; **Zero Gravity Pinball** by Mark Friedman; **Beer Run** by Arthur Little; **Advanced Star Raider Tactics and Strategies**

by C. Donald Harris Jr.

**531 Pickles & Trout CPIM for the TRS-80 Model II** by Hal Smith

**537 TRS-80 Disk Editor/Assemblers** by T. A. Daneluk

## Nucleus

**6** Editorial: Let There Be Talking People Too

**10** Letters

**270** Education Forum: Computers and the Special Education Classroom

**490** BYTELINES

**494** Software Received

**497** Clubs and Newsletters

**498** Books Received

**499** Ask BYTE

**501** BYTE's Bit

**502** Event Queue

**540** Desk-Top Wonder: Getting the Most from Your TI Programmer

**543** What's New?

**605** Unclassified Ads

**606** BOMB, BOMB Results

**607** Reader Service



Page 54



Page 92



Page 166



Page 362

Editor in Chief

**Christopher P. Morgan**

**Managing Editor**

Mark Haas

**Technical Editors**

Gregg Williams, Senior Editor;  
Richard S. Shuford, Curtis P. Feigel,  
George Stewart, Arthur Little,  
Stanley Wszola, Pamela Clark, Richard Malloy;  
Phillip Lemmons, West Coast Editor; Steve  
Ciarcia, Mark Dahmke, Consulting Editors;  
Jon Swanson, Drafting Editor

**Copy Editors**

Beverly Cronin, Chief;  
Faith Hanson, Warren Williamson, Anthony J.  
Lockwood, Hilary Selby Polk, Elizabeth Kepner,  
Nancy Hayes, Cathryn Baskin; Margaret Cook,  
Junior Copy Editor

**Assistants**

Faith Ferry, Debe Wheeler, Beverly Jackson

**Production**

David R. Anderson, Assoc. Director;  
Patrice Scribner, Jan Muller, Virginia Reardon;  
Sherry McCarthy, Chief Typographer;  
Debi Fredericks, Donna Sweeney,  
Valerie Horn

**Advertising**

Thomas Harvey, Director;  
Marion Carlson, Rob Hannings, Deborah  
Porter, Vicki Reynolds, Cathy A. R. Drew, Lisa  
Woznak; Jacqueline Earnshaw, Reader  
Service Coordinator; Wai Chiu Li, Advertising/  
Production Coordinator; Linda J. Sweeney

**Circulation**

Gregory Spitzfaden, Manager;  
Andrew Jackson, Asst. Manager;  
Agnes E. Perry, Barbara Varnum,  
Louise Menegus, Jennifer Price,  
Sheila A. Bamford;  
James Bingham, Dealer Sales;  
Deborah J. Cadwell, Asst;  
Linda Ryan

**Marketing**

Wilbur S. Watson, Marketing Coordinator;  
Timothy W. Taussig, Marketing Production  
Coordinator

**Controller's Office**

Daniel Rodrigues, Controller;  
Mary E. Fluhr, Acct. & D/P Mgr.; Karen  
Burgess, Jeanne Cilley, Linda Fluhr,  
Vicki Bennett, L. Bradley Browne

**Traffic**

N. Scott Gagnon, Scott Jackson,  
Kathleen Reckart

**Receptionist**

Jeanann Waters

**Publishers**

Virginia Londoner, Gordon R. Williamson;  
John E. Hayes, Associate Publisher;  
Cheryl A. Hurd, Michele P. Verville, Publisher's  
Assistants;

Officers of McGraw-Hill Publications Company: Paul F. McPherson, President; Executive Vice President: Gene W. Simpson; Senior Vice President-Editorial: Ralph R. Schulz; Vice Presidents: R. Bernard Alexander; Kemp Anderson, Business Systems Development; Harry L. Brown, Special Markets; Robert B. Doll, Circulation; James E. Hackett, Controller; Eric B. Herr, Planning and Development; H. John Sweger, Jr., Marketing.

Officers of the Corporation: Harold W. McGraw Jr., Chairman and Chief Executive Officer; Joseph L. Dionne, President and Chief Operating Officer; Robert N. Landes, Senior Vice President and Secretary; Ralph J. Webb, Treasurer.



## In This Issue

BYTE marks its seventh anniversary with the theme Computers and the Disabled, graphically illustrated on the cover by Robert Tinney. Gregg Vanderhelden discusses how "Computers Can Play a Dual Role for the Disabled," and with coauthor Paul Schwejdja demonstrates how to make an "Adaptive Firmware Card for the Apple II." David Stoffel reviews talking terminals for the blind, and William L. Rush evaluates the Abilityphone, a device for nonvocal communication. Patrick Demasco and Richard Foulds show how the Panasonic Hand-Held Computer can be used as a communication device in "A New Horizon for Nonvocal Communication Devices." Steve Ciarcia brings you his latest speech-synthesis system in "Build the Microvox Text-to-Speech Synthesizer: Part I—The Hardware," and Dr. William Murray reviews The Cognivox VI-1003, a speech-recognition system. Bruce Baker discusses his highly original Minspeak associative memory system for portable speech synthesis, and Alfred Fant Jr. shows you how to use a line printer to produce braille. In case you're thinking of marketing your own computerized aid, see our overview of the FDA's regulations concerning medical devices. In addition to our regular articles and reviews, we have BYTE's Arcade, and we start the countdown on our game contest winners.

BYTE is published monthly by BYTE Publications Inc, 70 Main St, Peterborough NH 03458, phone (603) 924-9281, a wholly-owned subsidiary of McGraw-Hill, Inc. Office hours: Mon-Thur 8:30 AM - 4:30 PM, Friday 8:30 AM - Noon, Eastern Time. Address subscriptions, change of address, USPS Form 3579, and fulfillment questions to BYTE Subscriptions, POB 590, Martinsville NJ 08836. Second class postage paid at Peterborough, N.H. 03458 and additional mailing offices. USPS Publication No. 528890 (ISSN 0360-5280). Canadian second class registration number 9321. Subscriptions are \$19 for one year, \$34 for two years, and \$49 for three years in the USA and its possessions. In Canada and Mexico, \$21 for one year, \$38 for two years, \$55 for three years. \$43 for one year air delivery to Europe, \$35 surface delivery elsewhere. Air delivery to selected areas at additional rates upon request. Single copy price is \$2.95 in the USA and its possessions, \$3.50 in Canada and Mexico, \$4.50 in Europe, and \$5.00 elsewhere. Foreign subscriptions and sales should be remitted in United States funds drawn on a US bank. Printed in United States of America.

Address all editorial correspondence to the editor at BYTE, POB 372, Hancock NH 03449. Unacceptable manuscripts will be returned if accompanied by sufficient first class postage. Not responsible for lost manuscripts or photos. Opinions expressed by the authors are not necessarily those of BYTE. Entire contents copyright © 1982 by BYTE Publications Inc. All rights reserved. Where necessary, permission is granted by the copyright owner for libraries and others registered with the Copyright Clearance Center (CCC) to photocopy any article herein for the base fee of \$1.00 per copy of the article or item plus 25 cents per page. Payment should be sent directly to the CCC, 21 Congress St, Salem MA 01970. Copying done for other than personal or internal reference use without the permission of McGraw-Hill is prohibited. Requests for special permission or bulk orders should be addressed to the publisher.

BYTE® is available in microform from University Microfilms International, 300 N Zeeb Rd, Dept PR, Ann Arbor MI 48106 USA or 18 Bedford Row, Dept PR, London WC1R 4EJ England.

Subscription questions or problems should be addressed to:

**BYTE Subscriber Service**  
P.O. Box 328  
Hancock, NH 03449



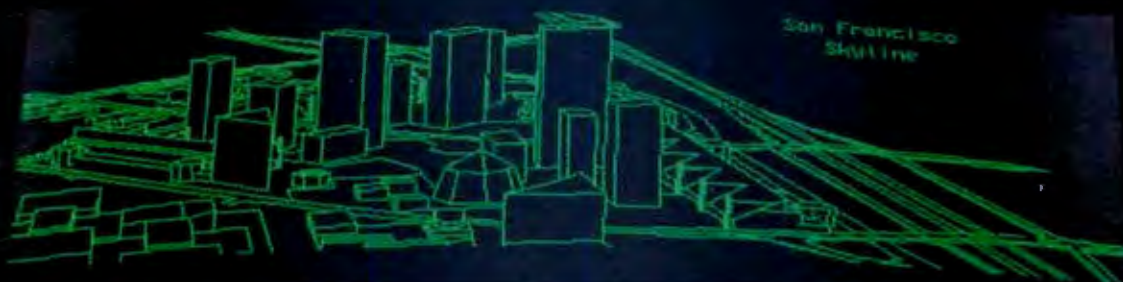

# ADD QUALITY GRAPHICS For Just \$711.\*



The OEM's best choice for graphics is MicroAngelo™, the single board graphics display computer from SCION. Install MicroAngelo in your Multibus or S-100 host and let this intelligent display processor bring your screen to life with full graphics and text. MicroAngelo features 512 by 480 pixel graphics and 40 line by 85 character text displays.

Save development time and overhead with SCREENWARE™, SCION's high level display firmware language. SCREENWARE provides point, vector, region, circle, flood, crosshair, light pen interface, tracking cross, screen load and dump, split screen, macro, and full terminal emulation commands. Use MicroAngelo both as your main console and as your application software's display screen.

MicroAngelo's on-board processor frees your host processor and bus to perform other tasks, while on-board memory and firmware reduce the size of your application programs. With our direct, easy interface to any high level language, you are no more than a simple sub-

routine call away from MicroAngelo's powerful capabilities. Use one MicroAngelo for monochrome graphics displays. And combine two or more MicroAngelos to create high resolution color graphics.

MicroAngelo is the OEM's choice because it is a powerful self-contained graphics display computer that is easy to add to your host. A graphics display computer that is proven reliable in over 1000 field installations. A graphics display computer that is so affordable you don't have to design your own.

**Think SCION for your graphics display needs. Think MicroAngelo. Call us at (703) 476-6100.**

\*OEM quantity 25 price for Multibus or S-100 board.

## SCION

**if the image is important.**

12310 Pinecrest Rd./Reston, VA 22091  
(703) 476-6100 TWX: 710-833-0684

Circle 416 on inquiry card

## MAINTAIN PROJECT CONTROL WITH MILESTONE®



Put your microcomputer  
to work...

As a project manager, you know the value of careful planning. An oversight here, a miscalculation there, and in no time, you could be in a lot of trouble.

Now, thanks to MILESTONE. Its easy to obtain and keep complete project control.

MILESTONE is an easy-to-use computer program that puts your desktop microcomputer to work using the same proven "critical path" techniques previously available only on big, expensive computers. Now, regardless of your type of project, you can plan and control manpower, dollars and time - with MILESTONE.

The price is \$295. (\$395. for the CP/M-86 version.) Manual alone is \$30.

Requires 56K RAM and CP/M, CP/M-86 or UCSD Pascal. Specify 8080/85, Z80, 8086 or UCSD version. Formats 8" single density IBM soft-sectored, 5 1/4" NorthStar DD, Micropolis Mod II, Superbrain 3.0, Apple II with CP/M, 5 1/4" and 8" Xerox 820, IBM Personal Computer with CP/M-86 and IBM DisplayWriter with CP/M-86.

See your computer dealer for  
details or contact us directly.

SOFTWARE  
SOFTWARE  
**DIGITAL MARKETING**  
DIGITAL MARKETING™



DIGITAL MARKETING CORPORATION

2670 CHEERY LANE • WALNUT CREEK • CALIFORNIA • 94596  
(415) 938-2880 • Telex: 47-1887 (DIGMKTG WNCR)

Milestone is a registered trademark of Organic Software.  
CP/M and CP/M-86 trademarks of Digital Research.  
UCSD Pascal trademark of Regent of University of California.

# Editorial

## Let There Be Talking People Too

by Mark Dahmke, Consulting Editor

When I was in college I met a fellow student who had great difficulties communicating because of cerebral palsy. We became friends and as things turned out I designed a voice-synthesizer system that greatly enhanced his ability to communicate. Designing this device was a logical extension of my long-time interest in electronics, microcomputers, and voice synthesis. My friend's case is a good example of how artificial aids—communicative or otherwise—can improve the quality of life for disabled persons.

Personal computers have done more for people with communicative disorders than any other technological development. Microcomputers are versatile machines that can be customized fairly easily to fit the individual needs of each person. Computers can be programmed to accept input from any kind of switch or device and to interpret that input in whatever way the user wants. As well, they can be made to respond with visual or audible output, opening up a new world to deaf and blind individuals.

Nearly 500,000 Americans who are not classified as retarded are unable to communicate either vocally or with standard hand signs. An even more sobering thought is that perhaps 100,000 or more individuals of normal intelligence are in institutions and have been diagnosed as retarded simply because they do not have the physical means to communicate. We do not even have accurate statistics in this area because of the nature of the disability. Assuming that the number of people with communicative disorders in this country amounts to two tenths of 1 percent of the population, then about 10 million people are affected world-wide.

While we now have the technology to *build* devices to compensate for almost any communicative disability, not everyone who needs a communication aid can *afford* one. They can't be mass produced because (ideally) they all require some customization. A similar situation prevails in the case of artificial limbs. Each prosthesis can cost thousands of dollars because of the relatively small market and because each limb is handmade for the individual. What we need are standard devices with plug-in memory modules, plug-in keyboard layouts, and modular-display or audio-output options. A communication aid could then be put together easily from two or three standardized modules and would fill 90 percent of the needs of most individuals with communication problems.





# Introducing the **PERCOM** Alternative to **ATARI** Disk Storage

Your Atari 800 is the finest home computer on the market. Now you can own a floppy disk system that measures up — an RFD mini-disk storage system from Percom.

At Percom we've been making disk storage systems since 1977.

Our designs are proven, our quality is well known. And we back our dealers with service know-how. Expect more from Percom. You won't be disappointed.

- Operate in either single- or double-density storage mode using Atari DOS 2.0S. In double-density you can store almost 184 Kbytes (formatted) on one side of a 40-track diskette.

For the best thing next to your computer, see your Atari dealer about a Percom RFD floppy disk storage system. For the name of your nearest dealer, call Percom toll-free 1-800-527-1222.

## PERCOM

PERCOM DATA COMPANY, INC.  
11220 Pagemill Rd. • DALLAS, TX 75243 • (214) 340-7081

ATARI 800 & ATARI 810 are trademarks of the Atari Corporation.  
PERCOM is a trademark of Percom Data Company, Inc.

- Connect your Percom RFD first-drive system directly to your computer or connect into your system through your Atari 810 Disk Drive.
- Add an RFD first-drive system with its versatile four-drive controller, then connect as many as three more low-cost RFD add-on drives.
- Write application programs that can query and set up your system to operate a different type drive at each cable position — that can even change configuration as the program executes.

- Get quality and state-of-the-art capability at competitive prices. Percom first-drive RFD systems are priced from only \$799, first add-on drive is only \$459. Cables included.

**Watch for announcement of a new, powerful, easy-to-use disk-operating system for your Percom-equipped Atari 800 computer.**

Minimum system requirements — are an Atari 800 computer with 24-Kbytes of RAM and compatible video display system; Atari's disk-operating system (ver 2.0S) and owner's manual; and, for add-on drives (if used) an optional disk drives interconnecting cable available from Percom.

Yes ... I'd like to know more about Percom RFD disk drives for my Atari 800 Computer. Rush me free literature.  
Send to: PERCOM DATA COMPANY, Inc., DEPT 18-801  
11220 Pagemill Road, Dallas, Texas 75243

name \_\_\_\_\_  
street \_\_\_\_\_  
city \_\_\_\_\_ state \_\_\_\_\_  
zip \_\_\_\_\_ phone number \_\_\_\_\_  
I plan to add a hard disk system to my Atari:  yes  no.  
**MAIL TODAY!**

PRICES AND SPECIFICATIONS  
SUBJECT TO CHANGE  
WITHOUT NOTICE.

One highly successful device currently on the market is the Texas Instruments Speak & Spell, which was designed as a children's learning tool. It has a reasonably large vocabulary and costs around \$50. In its current configuration, it can work as a communication aid if you ignore the spelling mode and simply type messages letter by letter. If, however, a few extra features had been incorporated into its design it could have very easily functioned as a communication aid and still cost \$50. It would have been the case of a mass-market product (with the price benefits of economies of scale and an extensive advertising campaign) doubling as a special-needs device. The integration of general-appeal consumer products with limited-market special-needs devices should be our goal. Thousands of people would benefit.

Recently Texas Instruments announced a new product called Vocaid, based on its Touch & Tell product. The \$150 device can be used by people with short-term communications problems. It also is a great communication aid for anyone with reasonably good coordination and cognitive skills. It can also accept memory modules that have specialized vocabularies. As such, it is a good practical application of customizing a standard product by plugging in memory modules.

Part of the problem faced by disabled individuals is the way they are perceived by the able-bodied members of society. Today we scarcely think of someone who wears

eyeglasses as disabled, yet before the discovery of the principles of optics, people with vision problems surely would not have been able to lead normal productive lives. I hope that in a similar way microcomputers will be able to help people with physical limitations overcome the restrictions to activity imposed on them by their disabilities and become, remain, and be viewed as productive members of society. It is an encouraging sign to see the proverbial "synthesizer on a chip." And now that we have the technology we must accept the challenge of making the fruits of that technology available to the people who will benefit the most.

On "Finding A Voice," a recent episode of NOVA on public television, John Eulenburg of Michigan State University said, "If there are going to be talking microwave ovens, let there be talking people too." ■

### Articles Policy

BYTE is continually seeking manuscripts of high quality written by individuals who are applying personal computer systems, designing such systems, or who have knowledge that will be useful to our readers. For a formal description of procedures and requirements, potential authors should send a legal-sized, self-addressed envelope with 37 cents U.S. postage affixed to BYTE Author's Guide, POB 372, Hancock, NH 03449.

Each month, the authors of the two leading articles in the reader poll (BYTE's Ongoing Monitor Box or BOMB) are presented with bonus checks of \$100 and \$50. Unsolicited materials should be accompanied by full name, address, and return postage.

## The Context MBA is available now at:

### California

ComputerLand/Aimaden 408/267-2182  
 ComputerLand/Belmont 415/595-4232  
 ComputerLand/Burlingame 415/348-7731  
 ComputerLand/Fremont 415/794-9311  
 ComputerLand/Hayward 415/538-8080  
 ComputerLand/Pasadena 213/449-3205  
 ComputerLand/Sacramento 916/920-8981  
 ComputerLand/San Diego 714/560-9912  
 ComputerLand/San Diego East 714/464-5656  
 ComputerLand/San Diego North 714/434-7001  
 ComputerLand/San Fernando Valley 213/716-7714  
 ComputerLand/San Francisco-Financial 415/546-1592  
 ComputerLand/San Francisco-Market Street 415/864-8080  
 ComputerLand/San Francisco-Van Ness 415/673-6640  
 ComputerLand/Sonoma 707/528-1775  
 ComputerLand/South Bay 213/371-7144  
 ComputerLand/Stockton 209/473-1241  
 ComputerLand/Thousand Oaks 805/495-3554  
 ComputerLand/Ventura 805/656-7711  
 ComputerLand/West Covina 213/960-6351  
 ComputerLand/West Los Angeles 213/559-3353  
 Personal Computer Business Systems/Irvine 714/540-1333

### Connecticut

ComputerLand/Danbury 203/748-2300  
 ComputerLand/Fairfield 203/255-9252  
 ComputerLand/Hartford 203/561-1446  
 ComputerLand/New Haven 203/288-5162  
 ComputerLand/Stamford 203/964-1224

### Illinois

ComputerLand/Arlington Heights 312/870-7500  
 ComputerLand/Downers Grove 312/964-7762  
 ComputerLand/Joliet 815/741-3303  
 ComputerLand/Lake County 312/949-1300  
 ComputerLand/Naperville 312/369-3511  
 ComputerLand/Niles 312/967-1714  
 ComputerLand/Northbrook 312/272-4703  
 ComputerLand/Oak Lawn 312/422-8080  
 ComputerLand/Schaumburg 312/843-7740

### Indiana

The Computer Room/South Bend 219/277-1600

### Kansas

ComputerLand/Lawrence 413/841-8611  
 ComputerLand/Overland Park 913/492-8882  
 ComputerLand/Topeka 913/267-6530

### Maine

ComputerLand/Portland 207/774-1309

### Massachusetts

Business Data Systems/Hanover 617/878-7888  
 ComputerLand/Boston 617/482-6033

### Michigan

ComputerLand/Ann Arbor 313/973-7075  
 ComputerLand/Grosse Pointe 313/772-6540  
 ComputerLand/Southfield 313/356-8111  
 Computer Mart/Ann Arbor 313/865-4453  
 Computer Mart/Flint 313/234-0181  
 Computer Mart/Kalamazoo 616/329-1000  
 Computer Mart/Lansing 517/351-1777  
 Computer Mart/Livonia 313/540-3928  
 Computer Mart/Tri-Cities 517/790-1360  
 Computer Mart/Troy 313/649-0910  
 The Computer Room/Grand Rapids 616/949-2802  
 The Computer Room/Kalamazoo 616/343-4634

### Minnesota

ComputerLand/Bloomington 612/884-1474  
 ComputerLand/Hopkins 612/933-8822  
 ComputerLand/Minneapolis 612/333-3151

### Missouri

ComputerLand/Gladstone 816/436-3737  
 ComputerLand/Independence 816/461-6502  
 ComputerLand/St. Joseph 816/364-4496

### New Hampshire

ComputerLand/Nashua 603/889-5238

### New Jersey

ComputerLand/Morrisstown 201/539-4077  
 ComputerLand/Princeton 609/882-1400

### New York

ComputerLand/Nassau County 516/742-2262  
 ComputerLand/Suffolk County 516/499-4484  
 ComputerLand/White Plains 914/328-0144  
 Future Data 212/964-6666  
 Morris Decision Systems/New York 212/742-9590

### Oregon

ComputerLand/Multnomah County 503/295-1828  
 ComputerLand/Salem 503/620-6170  
 ComputerLand/Portland 503/620-6170

### Pennsylvania

ComputerLand/Dresher 215/542-8835  
 ComputerLand/Harrisburg 717/783-1116  
 ComputerLand/Paoli 215/296-0210  
 ComputerLand/Philadelphia

### Texas

ComputerLand/Dallas 214/363-2223  
 ComputerLand/Fort Worth 817/292-7114  
 ComputerLand/Houston Bay Area 713/488-8153  
 ComputerLand/North Dallas 214/235-1285  
 ComputerLand/Southwest Houston 713/977-0909  
 ComputerLand/Tyler 214/581-7000  
 ComputerLand/Westwood 713/270-1200

### Virginia

ComputerLand/Richmond 804/741-3502  
 ComputerLand/Tyson's Corner 703/893-0424  
 ComputerLand/Woodbridge 703/491-4151

### Washington

ComputerLand/Bellevue 206/746-2070  
 ComputerLand/Federal Way 206/838-9363  
 ComputerLand/Lynnwood 206/774-6993  
 ComputerLand/Renton 206/271-8585  
 ComputerLand/Seattle 206/223-1075  
 ComputerLand/Tacoma 206/383-4951  
 ComputerLand/Vancouver 206/695-1540

### Washington, DC

ComputerLand/Washington, DC 202/835-2200

### Wisconsin

ComputerLand/Madison 608/273-2020

### Canada

Computer Mart/Windsor 519/968-5757

# Screen Test:

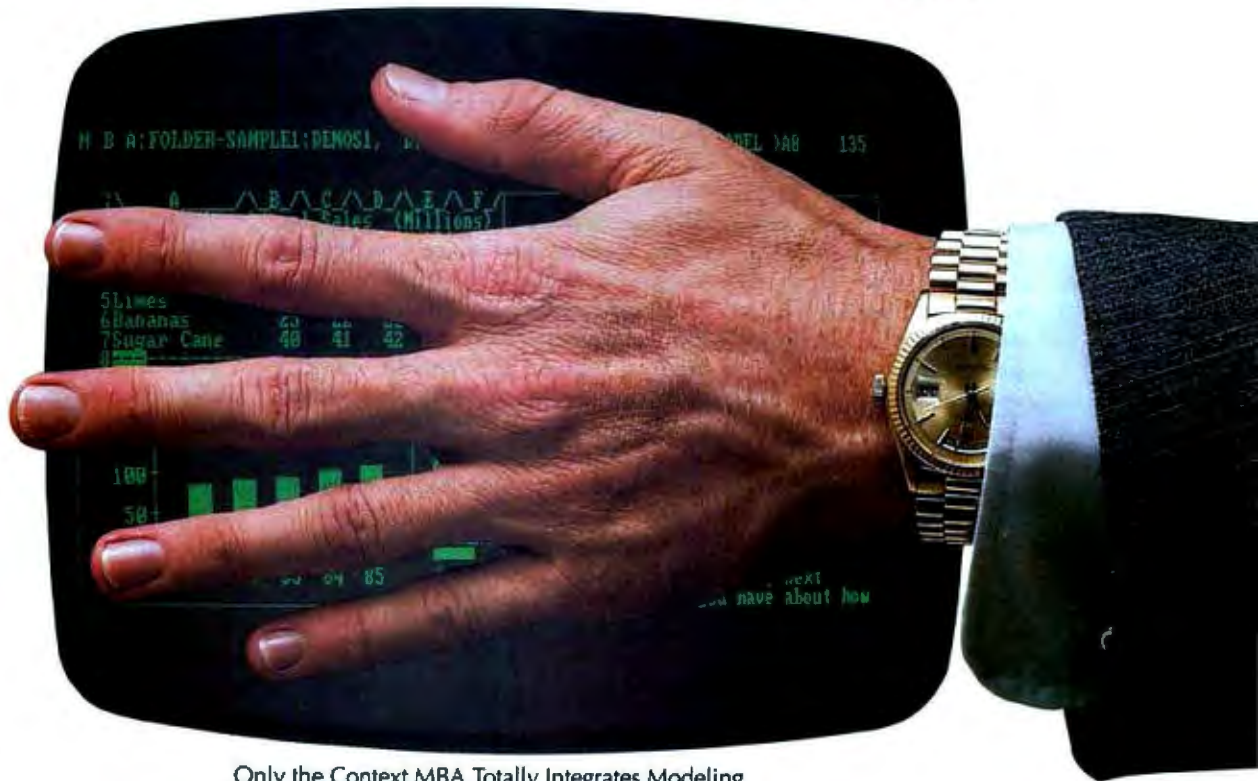

Only the Context MBA Totally Integrates Modeling,  
Word Processing, Database and Graphics in One Program.  
\_\_\_\_\_ TRUE \_\_\_\_\_ FALSE



The Context MBA turns second generation personal computers like the IBM into powerful management tools. Information entered in any of the C-MBA's four contexts can be used in any other context. Build a model using C-MBA's sophisticated electronic spreadsheet. Switch into database context by pressing three keys to quickly sort your model. When one picture is worth a thousand words (or numbers), a few keystrokes produce one of nine different graphs. Change your

numbers and your graphs automatically update as well.

The word processing context helps you write clear, concise reports. And you can copy in entire tables of numbers from your spreadsheet in seconds.

The Context MBA is far more than four integrated programs. It is a whole new concept in management software.

Personal computers are full of promise. Context makes them deliver. ©Copyright 1982 Context Management Systems

## Context

Management Software  
for Personal Computers

23864 Hawthorne Boulevard  
Torrance, CA 90505  
(213) 378-8277  
Telex 181149 WEST LSA

SOURCE ID TCA 442

## Response to Japanese Computers

As a BMC if800 user for the past year and a half, I read with interest the fine article "Six Personal Computers from Japan" by Christopher P. Kocher and Michael Keith (May 1982 BYTE, page 60). I was pleased to see that the section on the if800 was thorough and reasonably correct. The authors, however, made a few inaccurate statements that were probably due to omissions in the if800 documentation.

One of the inaccurate statements concerns the if800's screen-dump feature. The authors consider it a shortcoming that "... in dumping a screen image (as opposed to regular character-by-character text printing) the scan lines are spread quite far apart in the printed image, making text or detailed graphics difficult to read." They fail to mention, however, that the if800 has two additional screen-dump modes—one that prints a normal representation of what appears on the screen without the above-mentioned wide spacing, and another that prints a compacted representation of what appears on the screen. The widely spaced printout described in the article is obtained by pressing the Hard Copy key. The normally spaced printout is obtained by holding down the CTRL (Control) key while pressing the Hard Copy key. Likewise, the compacted printout is obtained by holding down the Shift key while pressing the Hard Copy key.

A second inaccuracy occurs in the subsection titled "Minor Gripes." Here the reader is led to believe that the if800 keyboard functions only in the uppercase mode, where the Shift key must be used to get lowercase characters. The if800 keyboard does, in fact, have a typewriter mode in which the Shift-key function is reversed; that is, lowercase characters are typed when the Shift key is not used, and uppercase characters are typed when the Shift key is used. The typewriter mode may be entered by simply pressing the Shift and COMD (Command) keys simultaneously. To return to the uppercase mode, press the CTRL and COMD keys together.

Ken Davison, Applications Engineer  
Oki Semiconductor Inc.  
1333 Lawrence Expressway, Suite 401  
Santa Clara, CA 95051

I would like to inform Christopher Kocher and Michael Keith that Canon CX-1 BASIC is definitely not the only BASIC with an XREF command. It may be the only BASIC running under CP/M with such a command, but CP/M isn't the only microcomputer operating system, or to my mind, the best. Phase One Systems has an excellent BASIC (running under the Oasis operating system) that includes XREF, which can be called from the interpreter or included as a compiler option. I think this version of BASIC is about as good as you can get with BASIC and still call it BASIC. It also has a good editor, which may stun some BASIC programmers.

Bob Pierce  
99 Golden Hinde Blvd.  
San Rafael, CA 94903

I'd like to clear up a common misconception about using multiple processors. In the article "Six Personal Computers from Japan," the authors repeatedly state that the Fujitsu FM-8 was the fastest machine in their test due to its "division of labor." A little reflection will reveal this to be false.

As stated in the article, the three microprocessors in the Fujitsu handle processing, video, and keyboard scanning. The authors did not realize that while running a BASIC benchmark the second and third processors are standing by in an idle loop. Because the programs that the authors chose do not involve graphics or extensive character I/O (input/output), they will not exercise the task-splitting features of the FM-8 computer.

As the designer of my own dual-processor upgrade for my SWTPC (Southwest Technical Products Corporation) computer, I've found that speed improvement is seldom a factor. In any program that does extensive computation, the I/O processor remains idle. In programs that do a lot of screen formatting, the main processor must wait. Only in those rare programs where computation and I/O are evenly split does my computer approach a theoretical speed improvement of 2 to 1.

So why do Fujitsu and I use multiple processors? In my case, I wanted to free the computation-processor memory space from the space required for the graphics storage. This use of multiple processors is mentioned in the BYTE article. If an

Apple or Radio Shack computer devoted 48K bytes of memory to graphics, there would be little left for the user. The FM-8 graphics resolution of 640 by 200 by 3 bits per pixel adds up to a total of 48K bytes of video memory. It was not mentioned in the article that 640 by 200 pixels can be divided into 25 lines and 80 columns of 8-by 8-bit character cells. This means the Fujitsu can plot letters in graphics with 80 characters per line.

What, then, makes the Fujitsu the fastest machine in the group tested? I would say it is a combination of its Motorola processor and a good BASIC interpreter. I can't overstress the fact that almost any hardware can run faster with better software. My vintage SWTPC 6800 in single-processor mode is about three times faster than the new Japanese machines. This is possibly due to the fast floating-point BASIC interpreter supplied by Technical Systems Consultants.

Leo Taylor  
18 Ridge Court West  
West Haven, CT 06516

## Another TRS-80 Hang-Up

Glenn Tesler's article "TRS-80 BASIC Program Hang-ups: The Reasons and Some Solutions" (May 1982 BYTE, page 318) was very well done and useful. I would like to extend his article with a practical suggestion for other programmers. I have noticed that programs containing PRINTUSING statements that have concatenated strings as statement elements eventually lead to program hang-ups in TRS-80 BASIC. A simple solution is to avoid concatenating strings in these statements by using alternative methods. For example, instead of

```
PRINTUSING"% (20 spaces) %";  
"A"+"", "+B$
```

try:

```
PRINTUSING"!";"A";:PRINT". ";:  
PRINTUSING"% (17 spaces) %";  
B$
```

You can use the addresses for "string work area" and "start of string data" pointers given in listing 2 of the article to verify the difference. This technique is

# NEC's new letter-quality printer gets personal with IBM.

**The Spinwriter™ 3550 lets the IBM PC get down to business.**

NEC's new Spinwriter letter-quality printer is the *only* one plug-compatible with the IBM Personal Computer. So you get the business applications you've been wishing for. Letter-quality output for word and data processing. Multi-language, scientific, and technical printing. Simple forms handling. Quiet operation. And the reliability of the industry's most popular printer line.

NEC designed the new Spinwriter especially for the IBM PC. It comes complete with documentation and training materials to fit your PC user's handbook. Just plug the Spinwriter in and your PC instantly becomes more versatile and flexible.

**More than 8 forms handlers and 50 print thimbles boost PC versatility.**

NEC designed the Spinwriter's 8 modular forms handlers to accommodate a wide range of paper and document sizes and types. The easily mounted handlers let your computer print out the forms you

need for data processing, word processing, graphics, accounting or other business applications.

The Spinwriter's 50 print thimbles can more than triple your PC's usefulness. They come in both constant pitch and proportional-spaced fonts, plus in foreign language, technical and scientific versions. They snap in and out in seconds, and let you print up to 203 columns on 16-inch paper. They each last for more than 30 million impressions.

**This printer's special features make everything look better on paper.**

The Spinwriter's software-invoked features include automatic proportional spacing; bidirectional, bold and shadow printing; justification; centering; under-scoring; and sub/super scripting, all at speeds up to 350 words per minute.

**That big extra, Spinwriter reliability.**

Spinwriters have the industry's best mean-time-between-failure rating, in excess of 3,000 hours. In terms of average personal computer usage, that's more than five years.

The Spinwriter 3550 is available at **ComputerLand** stores, **Sears Business Systems Centers** and **IBM Product Centers** nationwide.

NEC Information Systems, Inc.  
5 Militia Drive, Lexington, MA 02173

Send me more information on the Spinwriter 3550.

Name \_\_\_\_\_

Title \_\_\_\_\_ Telephone \_\_\_\_\_

Company \_\_\_\_\_

Address \_\_\_\_\_

City \_\_\_\_\_ State \_\_\_\_\_ Zip \_\_\_\_\_

BE982

Circle 339 on Inquiry card.

**NEC**

**NEC Information Systems, Inc.**

Spinwriter is a trademark of Nippon Electric Co., Ltd.

We're Made



for Each Other.



MICROPRO

## WordStar<sup>®</sup>

The number one selling microcomputer word processing package in the world.

8" CP/M<sup>®</sup>

LIST PRICE: 495.00  
MH PRICE: 289.00

5 1/4" APPLE<sup>®</sup>

LIST PRICE: 375.00  
MH PRICE: 234.00

MICROPRO

## MailMerge<sup>™</sup>

A multi-purpose text-data merging program. One of its most popular uses is producing personalized form letters. Requires WORDSTAR<sup>®</sup>

8" CP/M<sup>®</sup>

LIST PRICE: 150.00  
MH PRICE: 99.00

5 1/4" APPLE<sup>®</sup>

LIST PRICE: 125.00  
MH PRICE: 83.00

MAILMERGE, DATASTAR, SPELLSTAR, CALCSTAR, and SUPERSORT are trademarks of MicroPro International, San Rafael, California USA. QUICKCODE, QUICKSCREEN, and dUTIL are trademarks of Fox & Geller Associates. VISITREND/VISIPLOT, VISIFILE, VISISCHEDULE, VISIDEX, VISITERM, and DESKTOP PLAN are trademarks of VisiCorp. dBASE II is a trademark of Ashton-Tate. MATHSTAR is a trademark of Force Two, LTD. SUPERCALC is a trademark of Sorcim. SPELLGUARD is a trademark of Innovative Software Applications.

T.I.M. is a trademark of Innovative Software, Inc. CROSSTALK is a trademark of MicroStul. EASY WRITER and EASY SPELLER are trademarks of Information Unlimited Software. PERFECT WRITER and PERFECT SPELLER are trademarks of Perfect Software, Inc. WORDSTAR is a registered trademark of MicroPro International, San Rafael, California USA. VISICALC is a registered trademark of VisiCorp. CP/M is a registered trademark of Digital Research. APPLE is a registered trademark of Apple Computers. IBM is a registered trademark of International Business Machines.

MICROPRO

## DataStar<sup>™</sup>

The office-oriented system for data entry, retrieval, and updating. DATASTAR allows you to create a form, be it a price list, catalog, or order form. You can edit, update, or save this information in a file or simply print it out. DATASTAR interfaces with MAILMERGE and SUPERSORT.

8" CP/M

LIST PRICE: 350.00  
MH PRICE: 235.00

5 1/4" APPLE<sup>®</sup>

LIST PRICE: 295.00  
MH PRICE: 199.00

MICROPRO

## CalcStar<sup>™</sup>

Financial planning and business decision-making made simpler, faster, and more accurate. CALCSTAR calculates solutions to complex numerical problems in business and finance. CALCSTAR turns your microcomputer's video screen into a 'window' on a gigantic electronic ledger sheet with up to 600 entries arranged the way you want.

8" CP/M<sup>®</sup>

LIST PRICE: 295.00  
MH PRICE: 199.00

5 1/4" APPLE<sup>®</sup>

LIST PRICE: 195.00  
MH PRICE: 149.00

FORCE TWO, LTD

## MathStar<sup>™</sup>

MATHSTAR is a combination adding machine/calculator program, designed specifically for use with MicroPro's WORDSTAR<sup>®</sup>. Provides basic math functions, formatted results, and accounting notation.

8" CP/M<sup>®</sup>

LIST PRICE: 125.00  
MH PRICE: 99.00

5 1/4" APPLE<sup>®</sup>

Same as 8" CP/M<sup>®</sup>

ASHTON-TATE

## dBASE II<sup>™</sup>

THE database management system for the microcomputer.

8" CP/M<sup>®</sup>

LIST PRICE: 700.00  
MH PRICE: 489.00

5 1/4" APPLE<sup>®</sup>

Same as 8" CP/M<sup>®</sup>

FOX & GELLER

## QuickCode<sup>™</sup>

QUICKCODE allows dBASE II users to create the following programs, in a matter of seconds, without programming.

- Data entry programs
  - Data retrieval programs
  - Date edit/validation programs
  - Menus
  - dBASE II files
- PLUS: 4 New Data Types:
- Date
  - Dollars
  - Telephone
  - Social Security number

QUICKCODE includes a powerful new version of QUICKSCREEN, the dBASE II screen builder.

8" CP/M<sup>®</sup>

LIST PRICE: 295.00  
MH PRICE: 249.00

5 1/4" APPLE<sup>®</sup>

Same as 8" CP/M<sup>®</sup>

FOX & GELLER

## dUTIL<sup>™</sup>

dUTIL is the dBASE II utility program which saves valuable computer time and work by:

- Increasing command file running time
- Creating standard text files to use within your word processor
- Automatically debugging dBASE II command files

dUTIL does not require QUICKCODE or QUICKSCREEN.

8" CP/M<sup>®</sup>

LIST PRICE: 99.00  
MH PRICE: 75.00

5 1/4" APPLE<sup>®</sup>

Same as 8" CP/M<sup>®</sup>

Call Toll-Free: 1-800-523-9511

In Pennsylvania: 1-215-868-8219

# The Software:

# PACKAGES

	CP/M®		APPLE®	
	COMBINED LIST PRICE	MICROHOUSE PRICE	COMBINED LIST PRICE	MICROHOUSE PRICE
MH-1 WORDSTAR®/MAILMERGE	645.00	<b>319.00</b>	500.00	<b>259.00</b>
MH-2 WORDSTAR®/MAILMERGE/DATASTAR	995.00	<b>519.00</b>	795.00	<b>399.00</b>
MH-3 WORDSTAR®/CALCSTAR	790.00	<b>419.00</b>	570.00	<b>299.00</b>
MH-4 WORDSTAR®/MATHSTAR	620.00	<b>369.00</b>	500.00	<b>319.00</b>
MH-5 dBASE II/WORDSTAR®/MAILMERGE	1345.00	<b>819.00</b>	1200.00	<b>719.00</b>
MH-6 dBASE II/QUICKCODE/ WORDSTAR®/MAILMERGE	1640.00	<b>999.00</b>	1495.00	<b>899.00</b>
MH-7 dBASE II/QUICKCODE/dUTIL	1070.00	<b>749.00</b>	1070.00	<b>749.00</b>

## NEW: The IBM-PC Software Menu.

MICROPRO		IUS	
WordStar® .....	<b>289.00</b>	Easy Writer II .....	<b>299.00</b>
MailMerge .....	<b>99.00</b>	Easy Speller .....	<b>149.00</b>
SpellStar .....	<b>149.00</b>	PERFECT	
DataStar .....	<b>199.00</b>	Perfect Writer .....	<b>289.00</b>
SuperSort .....	<b>170.00</b>	Perfect Speller .....	<b>149.00</b>
CalcStar .....	<b>199.00</b>	SORCIM	
		SuperCalc .....	<b>209.00</b>
VISICORP		ISA	
VisiCalc® .....	<b>190.00</b>	SpellGuard .....	<b>249.00</b>
VisiTrend/VisiPlot .....	<b>228.00</b>	ISI	
VisiFile .....	<b>169.00</b>	T.I.M. ....	<b>399.00</b>
VisiPlot .....	<b>179.00</b>	MICROSTUF	
VisiSchedule .....	<b>249.00</b>	CrossTalk .....	<b>119.00</b>
VisiDex .....	<b>190.00</b>	ASHTON-TATE	
VisiTerm .....	<b>80.00</b>	dBASE II .....	<b>CALL</b>
Desktop Plan .....	<b>190.00</b>		

# MICROHOUSE™

The Microcomputer People.™

**Compliment  
your  
Apple III®  
or IBM...**



## Introductory Offer...

**COLOR RGB MONITORS  
BUY DIRECT!!**

# \$389<sup>00</sup>

*plus \$9.50 shipping & handling.*

- \* 13" RGB Color.
- \* 8 Colors standard.
- \* 16 Colors on your IBM or Apple III.
- \* Analog
- \* Up to 80 Characters per line.
- \* 360 Dots per color. (horizontal resolution)

Apple III and IBM customers please add \$29.50 for factory installed mod board.

MasterCard / VISA / American Express / Prepaid / C.O.D.

Call Toll Free for immediate shipment: **1-800-258-6370**

© Apple III is a registered trademark of Apple Computer.

Monitors by  
**TECO**

**dataled**

18 Bridge Street, Salem, NH 03079  
Tel. (603) 893-2047  
TWX: 710-366-0502

## Letters

especially helpful in programs with lots of menus.

William S. Wise, M.D.  
President  
Datalab Corp.  
2652 Edgerton Rd.  
University Heights, OH 44118

Thank you for publishing Glenn Tesler's article "TRS-80 BASIC Program Hang-ups: The Reasons and Some Solutions." If anyone wishes to get in touch with Glenn, his correct address is Glenn Tesler, Prosoft, POB 839, North Hollywood, CA 91603.

Your readers might also be interested to know that Glenn was barely 12 years old when he wrote that article.

Although he didn't know it at the time the article was written, Glenn now says that many of the techniques presented in the article apply to Microsoft BASIC on the Apple, the IBM Personal Computer, and many other microcomputers.

Debbie Tesler  
Prosoft  
POB 839  
North Hollywood, CA 91603

### Why Advertisers Don't Respond

We read with interest the letter to the editor from H. B. Brandon regarding the lack of interest some advertisers showed concerning inquiries about their equipment or software (May 1982 BYTE, page 19). Our firm specializes in designing and optimizing small computer systems for industry and small-business use. We often experience the same frustration and delay that Mr. Brandon found. Typically, it is not that the manufacturers intend to be rude or inapproachable, but rather that they are simply swamped. For production lines, customer services, sales forces, etc. to be scaled up to meet the demand requires a very long lead time plus long-range forecasting to meet future demand. Personnel must be hired and trained, and telephone lines must be added to handle orders and inquiries. Sometimes the entire staff must be relocated to more spacious quarters. Then of course, letters can be lost. We offer this not as an excuse but as an explanation and ask you not to be too

harsh in your judgment of these companies.

Thomas M. Krischan, Chief Executive Officer  
Technimetrics Computer Consulting  
646 South 93rd St.  
West Allis, WI 53214

### Buffer Overflow Cure

I enjoyed reading John Blankenship's "Give Your Apple a Voice: A Speech-Development System Using the Radio Shack Speech Synthesizer" (May 1982 BYTE, page 446). However, like most articles on the Radio Shack Speech Synthesizer, it overlooked the fact that this device contains only a 32-byte buffer and has no control over preventing buffer overflow. There is a simple cure for this problem; it requires a small hardware modification to the synthesizer and the availability of a single input line to the computer. First, bring out pin 2 of IC4, as marked on the circuit board, to an unused wire of the ribbon cable. On the computer end of the ribbon cable connect this line to an input port that can be read by your program. The signal you have just wired to an input port will indicate by a low voltage that the synthesizer buffer is full. It will go to a high-voltage state when there is again room in the buffer.

Ralph J. Jannelli  
101 Cottonwood Dr.  
Jamestown, NC 27282

We congratulate Mr. Blankenship on his excellent article. The program listing he provided should be quite helpful to owners of the Radio Shack Speech Synthesizer. As an update to the article, please note that while the Radio Shack Speech Synthesizer was designed and manufactured by Votrax for Radio Shack, the unit uses a Votrax VST synthesizer module, not an SC-01A speech chip. It may interest your readers to know that the SC-01A is currently available in a Votrax product called Type-N-Talk, a text-to-speech computer peripheral with unlimited vocabulary and an RS-232C interface. Type-N-Talk utilizes a program similar to that developed by Mr. Blanken-



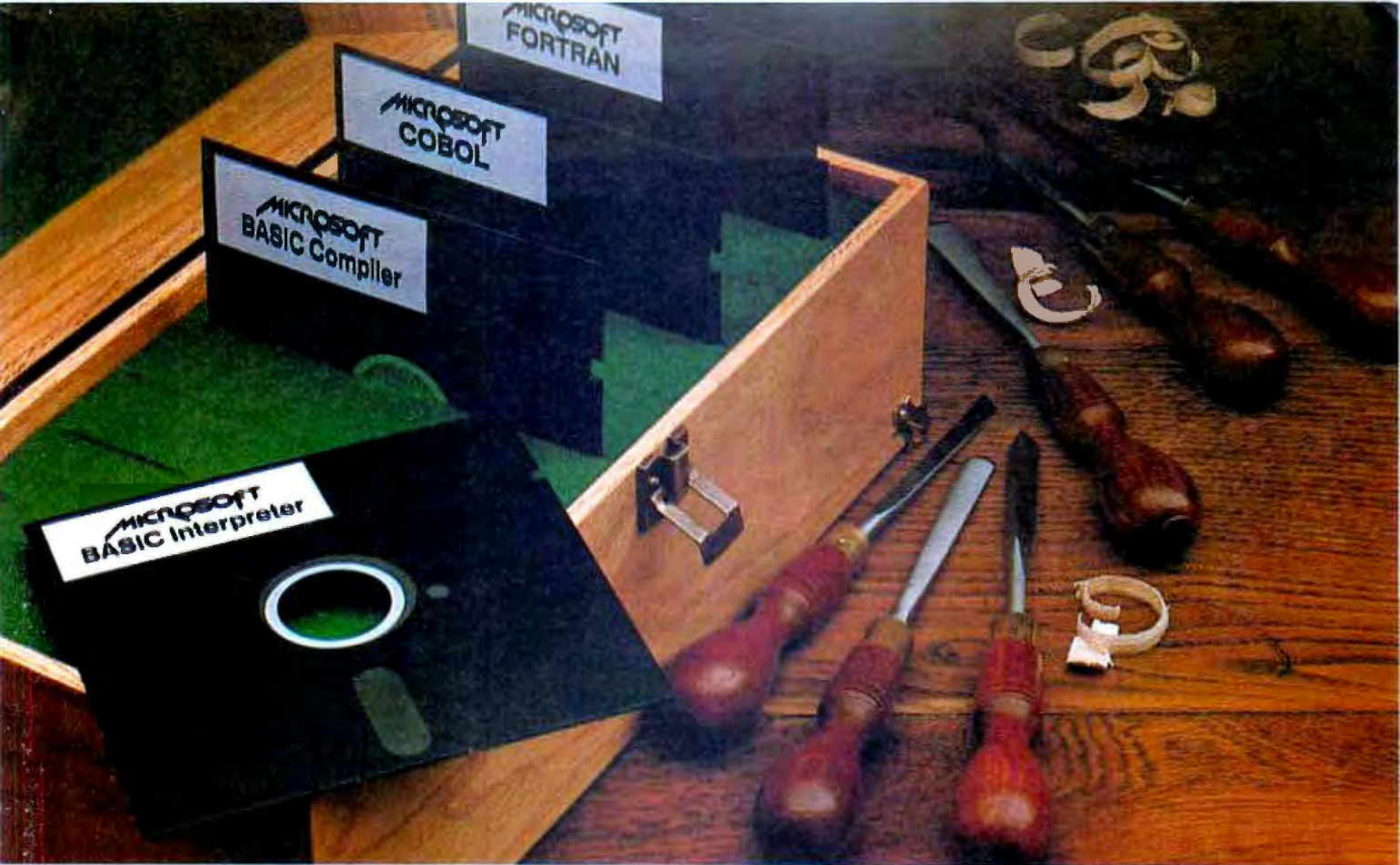

## Proven tools for programmers. From Microsoft.

**Old friends.** Eight years ago, Microsoft put BASIC on the first microcomputer. Today, there are more than 1,000,000 copies of Microsoft™ languages in use. BASIC interpreter. BASIC compiler. FORTRAN, and COBOL. A proven set of programming tools. All, fully supported by Microsoft.

**The best get better.** Good tools work better if you keep them sharp. That's why we constantly improve the tools we offer. Enhancing them. Increasing their utility. Taking full advantage of the strengths of each language. Supporting you, the user, with a full range of finely honed programming tools.

**Technical support.** When you buy our tools, you get our number. If you have technical problems, call the Microsoft support staff for assistance. If we don't have the answers now, we'll find them and call you back.

**Compatible documentation.** All Microsoft languages share a common approach to documentation. Starting with plain English. That means that even when you're learning a new language, you won't have to learn a new vocabulary.

**Linkable code.** All Microsoft compilers share common utilities. A linker accompanies each

compiler. That means you can write programs in two or more languages, taking advantage of the specific strengths of each, then, link and run them as a single program.

**Leadership in micros.** Nobody gave us leadership. We earned it through innovation, enhanced programming tools and complete user support. Today, Microsoft is the only software supplier to offer you a complete programming environment. Including specialized languages that support you in a wide variety of programming situations. Tomorrow, you can look to Microsoft to make that environment even more productive.

**Better tools.** Ask your Microsoft dealer about Microsoft's family of proven tools for programmers: BASIC interpreter, BASIC compiler, FORTRAN and COBOL. Each is a specialized tool for a special programming problem. Better tools. And better tools make better programs.



BETTER TOOLS FOR MICROCOMPUTERS

# MICROSOFT

Microsoft Corporation  
10700 Northup Way  
Bellevue, WA 98004

Microsoft is a trademark of Microsoft Corporation.

# Speaking graphically...



## it really pays to rent terminals and desktop computers from Genstar REI!

You can rent — right now, off-the-shelf, for as short as 30 days — Hewlett-Packard desktop computers, intelligent graphics terminals, graphics terminals, digitizers and thermal graphics printers. Plus, you can rent dot matrix printers, graphic printers, impact printers and teleprinters from Centronics, HP, Tally, Texas Instruments, Qume, and more. Also, data terminals from ADDS, Beehive, Computer Devices, HP, Lear Siegler, Tektronix, Televideo Systems, TI, and others. We've also got modems and acoustic couplers immediately available for rent throughout North America. Think of your bottom line in graphic terms. Rent from Genstar REI. Today!

**GENSTAR**

**Rental Electronics, Inc.**  
**(800) 227-8409**

In California (213) 993-7368, (415) 968-8845, (714) 879-0561

GSA Contract #GS-04S-23560

**Show me the savings picture, REI. Send me a Free Catalog now!**

- It sounds great. Tell me more! Call me at \_\_\_\_\_
- Send me your new Rental Catalog.
- I'd like a copy of your "like new" equipment for sale catalog, too.
- I'm particularly interested in the following equipment: \_\_\_\_\_

NAME \_\_\_\_\_ TITLE \_\_\_\_\_

ORGANIZATION \_\_\_\_\_

ADDRESS \_\_\_\_\_ MAIL STOP \_\_\_\_\_

CITY/STATE/ZIP \_\_\_\_\_

TELEPHONE \_\_\_\_\_ B982

Please complete coupon and mail to: Genstar Rental Electronics, Inc., 19525 Business Center Drive, Northridge, CA 91324

© Genstar Rental Electronics, Inc. 1982

## Letters

ship for the Radio Shack unit, but the software is self-contained within Type-N-Talk and requires no additional programming on the part of the user. Mr. Blankenship's statement that "quality was more a function of the programmer than of the hardware" is all too true, but with the introduction of programs such as his for the Radio Shack unit and Type-N-Talk more and more users can now add voice to their computers without first becoming specialists in phonetic speech synthesis.

Melanie J. Moyna, Manager  
Consumer Products Group

Votrax

Division of Federal Screw Works  
500 Stephenson Highway  
Troy, MI 48084

*The Votrax SC-01A chip is also used in Steve Ciarcia's project this month. See "Build the Microvox Text-to-Speech Synthesizer, Part 1: Hardware," on page 64. . . . R.S.S.*

## Computing Careers

Jacqueline Johnston's article "Career Opportunities in Computing" (April 1982 BYTE, p. 439) was very informative and useful. I enjoyed it because I am currently seeking a job as an entry-level programmer. As a result, I have some observations that may interest the audience addressed by Ms. Johnston's article.

There are indeed many openings out there for programmers and programmer-analysts. This fact is readily apparent from the classified pages of the major metropolitan newspapers. But very few of the advertised openings are for entry-level personnel, and many firms demand qualifications that even an experienced professional may have difficulty meeting.

Entry-level programmers who do not have access to a school placement service or a diligent guidance counselor will probably have to knock on a lot of doors in order to find entry-level positions. This could be an expensive proposition for anyone who resides, as I do, in an area remote from the urban centers where there is the greatest demand for computer personnel. Private employment agencies are of little help because, although clients will pay an agency to find experienced programmers, companies apparently prefer to obtain entry-level personnel through campus recruiting and walk-ins.



## Letters

Most advertised openings I have seen now specify two to five years' experience in addition to the expected knowledge of a specific computer language. While many hobbyists may meet those qualifications, the job seeker should also realize that most advertisements now demand experience on specific types of computers and knowledge of specific operating and/or database systems. These prerequisites presumably exclude those professionals who are familiar with the "wrong" machine or system. They certainly exclude those hobbyists who have had no opportunity to work with minicomputers and mainframes.

These demands for specialization in one brand or line of hardware or software seem unrealistic. After all, much of what we do as programmers is medium independent, there is a shortage of computer personnel, the differences between brands of hardware and software are not huge, and new brands or lines of hardware and software are coming into the market almost daily. The employers obviously want no time wasted on training or retraining computer personnel; perhaps high salaries are at fault.

These observations are not meant to discourage anyone interested in a programming job or career. The opportu-

nities are out there, but finding a position that's right for you may not be quite as easy or fast as it once was or as some sources would indicate.

La Vaughn H. Hayes  
2021 Biltmore Dr.  
Fayetteville, NC 28304

### Disclaimer May Not Be Valid

I read with interest John Navas's letter regarding warranties and software (May 1982 BYTE, page 18), and I'd like to inform Mr. Navas that just because a disclaimer is printed doesn't mean it is valid.

Assuming Mr. Navas's software can be termed "goods" under the Uniform Commercial Code, Section 2-316 of that code applies. This section requires that for a disclaimer to be valid, it must be conspicuous and in writing.

Conspicuousness in this context is readily determined. Usually the disclaimer must appear in capital letters and in a typeface that contrasts with the surrounding typefaces. If a disclaimer is indistinguishable from the rest of the sales contract or agreement, it is not conspicuous.

Furthermore, it is required that the purchaser either have or should have had actual knowledge of the disclaimer prior to the sale. A warranty cannot be disclaimed after a sale.

Finally, even if there is a disclaimer, the disclaimer will not excuse the failure to supply the goods forming the basis of the bargain. For example, if Mr. Navas bought a checkbook maintenance program, the product must function as a checkbook maintenance program. If the software or hardware delivered is so riddled with bugs that it will not operate, the seller did not deliver what was bargained for.

L. J. Kutten  
201 South Central  
POB 16185  
St. Louis, MO 63105

### A Fix for the Soundex Algorithm

The algorithm given in Jacob R. Jacobs's "Finding Words That Sound Alike: The Soundex Algorithm" (March 1982 BYTE, page 473) can be improved simply by eliminating the code element

## COMPUTER FORMS AND SUPPLIES

### WE SUPPORT MORE SYSTEMS WITH FORMS THAN ANYONE!

INVOICES • STATEMENTS • CHECKS • P.O.'s • SHIPPERS • MEDICAL FORMS

Accounting Plus • Peachtree • BPI • Open Systems • Structured Systems • Vector Graphic • Howard • Radio Shack • Continental • Designer • Libra • Gold • IMS • Alpha Micro • Cimarron • Van Data • Durango • Dynabyte • Osborne • Brlareus • MCBA • Apple • Great Plains • Emeritus

WE SUPPORT 215 SYSTEMS NOT LISTED HERE, SO IF YOU DON'T SEE YOUR SOFTWARE HERE CALL TOLL FREE FOR A FREE SAMPLE PACKET OF FORMS FOR YOUR SOFTWARE.

### WORD PROCESSING LETTERHEAD

SHEER CUT LETTERHEAD FROM CHECKS TO-GO USES A NEW PROCESS TO PRODUCE CONTINUOUS FORM PAPER THAT TRIMS CLEAN WHEN BURST. NORMAL COMPUTER PAPER USES FIVE PERFORATIONS PER INCH, BUT SHEER CUT USES A NEW TECHNOLOGY TO PRODUCE 80 PERFS OR "TIES" PER INCH. THIS PRODUCES A VERY CLEAN AND UNIFORM EDGE WHEN BURST, AND IS ECONOMICAL IN BOTH SMALL AND LARGE QUANTITIES. SHEER CUT IS AVAILABLE ON A STOCK FORM BASIS IN FOUR "CLASSIC LAID" PAPERS, OR IN ANY TYPE PAPER ON A CUSTOM ORDER. EVERY OTHER FORM CAN BE IMPRINTED TO PRODUCE CONTINUOUS FIRST AND SECOND SHEETS. BLANK PRICES ARE \$60 FOR 1,000, \$235 FOR 5,000 AND \$400 FOR 10,000, WITH IMPRINTING, DEALER, AND VOLUME PRICING AVAILABLE.

### TAX FORMS

Call for your free 1982 continuous tax form catalogue.

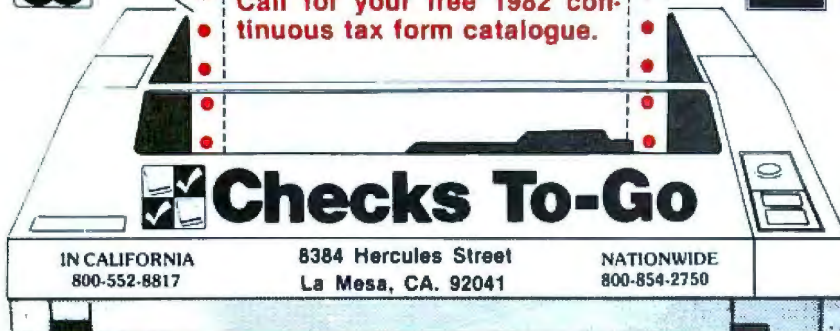

IN CALIFORNIA  
800-552-8817

8384 Hercules Street  
La Mesa, CA. 92041

NATIONWIDE  
800-854-2750

CALL TOLL FREE: (800) 854-2750 IN CA (800) 552-8817

# new faces

## 15 type styles for the IBM PC and Apple II

With this program your dot matrix printer  
can output 15 large typefaces.

Type Faces generates distinctive presentations, fancy lettering,  
invitations, easy to read output, and over 100 symbols.  
Reduced printout on a copier gives you letter quality text  
on an inexpensive typesetter.

Type Faces comes with its own simple text editor and is  
compatible with most word processors.

Actual dot matrix printout

Reduced dot matrix printout  
gives you letter quality text

ABC abc	ABC abc
ABC abc	ABC abc
ABC abc	ABC abc
ABC abc	ABC abc
ABC abc	ABC abc

Alpha software products available at participating ComputerLands  
Or call us for your nearest dealer: 617 229-2924



6 New England Executive Park • Burlington, Massachusetts 01803

Type Faces supports Epson and IDS dot matrix printers. Type Faces: \$95

Circle 19 on inquiry card.



Type Faces



alpha

SOFTWARE FOR  
IBM and APPLE

## Letters

for vowels only after consecutive repeated elements are eliminated. With this fix, the routine will correctly discriminate between words like "decision" and "thicken" because similarly coded consonants separated by vowels are preserved. The earliest document I know of that describes the Soundex method with this change is "Information Retrieval by Proper Name" by W. L. Hewes and K. H. Stow (June 1965 *Data Processing*, page 18).

John Nesbit  
9808 110th St.  
Edmonton, Alberta  
Canada

### Wanted: FORT/80

My company has a problem: a number of our customers have bought and are using FORT/80, a FORTRAN compiler produced by Unified Technologies Inc. of Islington, Ontario. Our customers find the compiler an excellent product, if a little lacking in some advanced features. Unfortunately, we believe Unified Technologies ceased trading some time ago, and we

cannot contact them.

We would appreciate any information on the availability of the FORT/80 compiler.

D.G. Collier, Software Director  
Data Applications [UK] Ltd.  
16B Dyer St.  
Cirencester  
Gloucestershire, GL7 2PF  
United Kingdom

### MPI Disk Drives Meet IBM

The following information may be useful to anyone considering purchasing the IBM Personal Computer.

Recently, I decided to upgrade to a 16-bit computer. I first purchased the IBM *Technical Reference* manual and later bought the IBM Personal Computer. Why did I buy the technical manual first? I wanted to know if there was any reason why IBM's Tandon-made disk drives could not be replaced with my MPI (Micro Peripherals Inc.) B51 drives.

Last week, I brought home my newly acquired Personal Computer system with

the DOS (disk operating system) manual, a disk-controller board, a color-graphics board, and an additional 16K bytes of memory. That same evening my system was up and running with the DOS and one of the B51 drives. Unfortunately, when I attached the second disk drive neither drive would work. I found that making the MUX (multiplex) connection on the MPI shunt socket for the Tandon drive, as described in the *Technical Reference* manual, does not work on the MPI drives, because the drive electronics are then enabled all the time. Therefore, the outputs of the two drives contend with each other. Fortunately, no damage can occur with open-collector drive circuits. The solution is simple: do not make the MUX shunt connection. Also, the disk-controller board places a logic low voltage on pin 34, Side Select, and this must always be logic high for the MPI B51 drives.

The following information will allow anyone who wants to use MPI B51 drives to have a system up and running in no time with the IBM Personal Computer and DOS:

- Each MPI drive must be set up to receive its Drive Select signal on pin 12 of its edge connector.
- The Drive Select signal must also enable the Head Load line.
- The MPI drives' Side Select lines must always be logic high.

The above conditions can be achieved by placing two jumper connections across the following pins of the shunt socket on the MPI drives:

- 1 to 14 (Head Load connecting to Drive Select)
- 3 to 12 (Drive Select connecting with pin 12)

and cutting the trace on the MPI printed-circuit board leading to pin 34 of the edge connector (just above the contact), allowing this pin to stay in the high state.

Note that the termination-resistor pack (150-ohm pull-up resistors) should be left in the A drive only; remove this pack from the B drive but place a single 150-ohm resistor between pins 2 and 13 of this socket. This pulls the Side Select line up to the high state.

Kim B. Lignell  
649 South Harvard Ave.  
Addison, IL 60101 ■

## BYTEWRITER

### DAISY WHEEL PRINTER LETTER QUALITY PRINTER AND TYPEWRITER IN ONE PACKAGE

The BYTEWRITER is a new Olivetti Praxis 30 electronic typewriter with a micro-processor controlled driver added internally.



**\$795**  
plus shipping

Dealer  
Inquiries  
Invited

#### FEATURES

- Underlining • 10, 12, or 15 characters per inch switch selectable • 2nd keyboard with foreign grammar symbols switch selectable • Changeable type daisy wheel
- Centronics-compatible parallel input operates with TRS-80, Apple, Osborne, IBM and others • Cartridge ribbon • Typewriter operation with nothing to disconnect
- Service from any Olivetti dealer • Self test program built in.

## BYTEWRITER

125 NORTHVIEW RD., ITHACA, N.Y. 14850  
(607) 272-1132

Praxis 30 is a trademark of Olivetti Corp.  
TRS-80 is a trademark of Tandy Corp.  
BYTEWRITER is a trademark of Williams Laboratories.



# Turn your Apple<sup>\*</sup> III into an Orchard



## With software from Quark<sup>TM</sup> Engineering

Quark Engineering brings you software specially designed for your Apple III. Easy-to-use products that dramatically increase your system's capabilities. And **your** productivity.

You start with Word Juggler<sup>TM</sup>, the most easy-to-use word processor available for the Apple III. Word Juggler is written in assembly language. And comes with special keyboard templates to label important functions.

Word Juggler retails for \$295. Form letter and simple mailing list capabilities are included free. If you want even more capacity, you can interface with Apple's Mail List Manager for an additional \$35.

Need to check your spelling? Add Lexicheck<sup>TM</sup>. A high-performance spelling checker with a 25,000-word dictionary. You can add your own words. And get more accurate documents, without a lot of proofreading. The price? Less than a penny a word. Only \$195.

You can even send text from Word Juggler to computerized typesetting equipment. All you need is Typeface<sup>TM</sup>. Interface software which cuts your typesetting costs and eliminates re-keying errors. \$175.

Finally, there's TranScribe<sup>TM</sup>. A spooler designed especially for hard disk drives. TranScribe lets you use other computer functions while you're printing. And it's compatible with most Apple III software. \$125.

There's much more to tell you about Word Juggler, Lexicheck, Typeface and TranScribe. See them at your local dealer. Or contact us today. We'll help you turn your Apple III into an orchard. And from then on, you'll find easy picking.

Quark Engineering  
1433 Williams, Suite 1102  
Denver, CO 80218  
(303) 399-1096



## Quark

\*Apple is a registered trademark of Apple Computer, Inc.  
Circle 391 on inquiry card.

See us at Applefest/San Francisco, Booth #529.

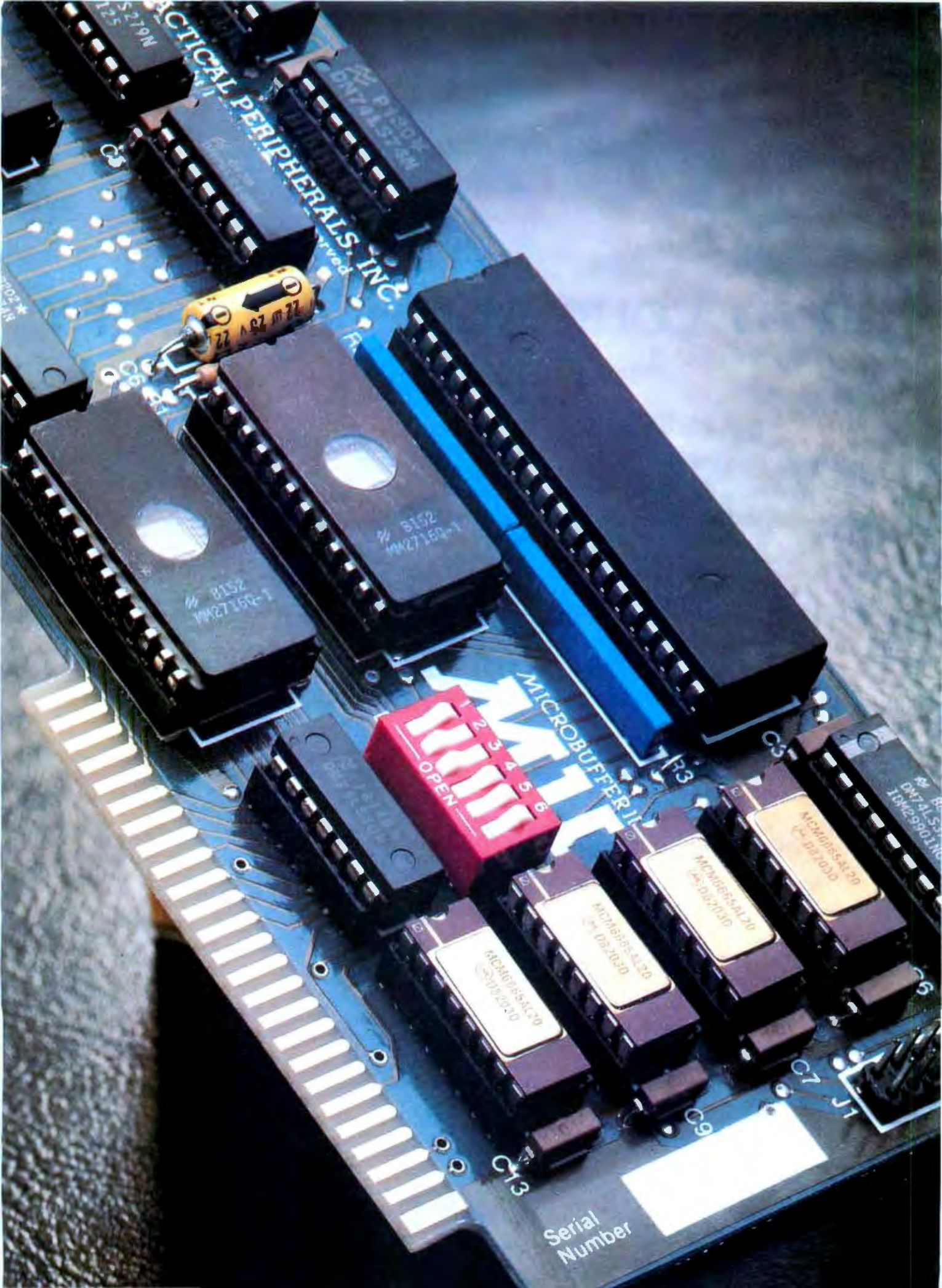

ACTICAL PERIPHERALS, INC.  
# 8152 MK27150-1

# 8152 MK27150-1  
# 8152 MK27150-1

MICROBUFFER II

1 2 3 4 5 6  
OPEN

MCMB8554120  
MCMB8554120  
MCMB8554120

Serial Number



# MICROBUFFER WILL SPEED UP ANY PROGRAM THAT REQUIRES PRINTING.

## **MICROBUFFER ALLOWS YOU TO PRINT AND PROCESS SIMULTANEOUSLY.**

Now you don't have to wait for the printer to finish before you can use your computer again.

## **YOU CAN DUMP PRINTING DATA DIRECTLY TO MICROBUFFER.**

Unlike your printer, Microbuffer accepts data as fast as your computer can send it. So there's never a bottleneck.

Microbuffer first stores the data in its own memory buffer and then takes control of your printer. This frees the computer for more productive functions.

Additional output may be dumped to the buffer at any time and it will be printed in turn.

## **THERE IS A MICROBUFFER FOR ANY PRINTER/COMPUTER COMBINATION.**

Microbuffers are available in Centronics-compatible parallel or RS-232C serial versions.

FOR APPLE II COMPUTERS, Microbuffer II features on-board

firmware for text formatting and advanced graphics dump routines. Both serial and parallel versions have very low power consumption. Special functions include Basic listing formatter, self-test, buffer zap, and transparent and maintain modes. The 16K model is priced at \$259 and the 32K, at \$299.

FOR EPSON PRINTERS, Microbuffer is \$159 in either an 8K serial or a 16K parallel version. The serial buffer supports both hardware handshaking and XON-XOFF software handshaking at baud rates up to 19,200. Both Epson interfaces are compatible with all Epson commands including GRAFTRAX-80 and GRAFTRAX-80+.

ALL OTHER PRINTER/COMPUTER COMBINATIONS are served by the in-line, stand-alone Microbuffers. Both serial and parallel versions are expandable up to 256K. The serial stand-alone will support different input and output baud rates and handshake protocol. The 32K model starts at \$299, 64K for \$349. 64K add-ons for up to a total of 256K are just \$179.

When you think of how much time Microbuffer will save, can you afford to *not* have one?

## **SIMPLE TO INSTALL.**

Microbuffer II is slot-independent. It will fit directly inside the Apple II in any slot except zero.

Microbuffer for your Epson mounts easily in the existing auxiliary slot directly inside the printer.

The stand-alone Microbuffer is installed in-line between virtually any printer and computer.

## **MICROBUFFER FROM PRACTICAL PERIPHERALS.**

Practical Peripherals is dedicated to establishing new industry standards for product performance.

The un-retouched photo at left has been enlarged to demonstrate Microbuffer's exact workmanship and precise attention to detail. Specifications demand that each board undergo 36 separate tests and inspections before it can leave the factory.

Ask your dealer for a demonstration of the most practical, most successful new product of the year — Microbuffer.

PRACTICAL PERIPHERALS, INC.  
31245 LA BAYA DRIVE  
WESTLAKE VILLAGE, CA 91362  
(213) 991-8200

## Quinti-Maze

Robert Tsuk  
17 Lexington Ave.  
Plattsburgh, NY 12901

The Quinti-Maze game takes you on a three-dimensional adventure through a 5-by-5-by-5 cubic maze. The object of the game is to find your way through the rooms and out of the maze in as little time as possible.

The program is written in Applesoft BASIC for an Apple II with 32K bytes of memory and one disk drive. Although it's written in BASIC, Quinti-Maze is a fast game to play (see listing 1). But setting up the maze takes about 30 seconds (see photo 1). One room at a time appears on the screen, showing you four possible exits—one in each of the three visible walls and one in either the floor or ceiling.

### Playing the Game

At the start of the game, you're asked if you want to see the instructions. If you don't, the screen then displays a view of one of the rooms, in high-resolution graphics, located somewhere in the maze. The direction in which you are facing is indicated at the bottom center of the screen.

You move around the maze by entering any of the following commands:

U—up	E—east
D—down	W—west
N—north	F—change facing direction
S—south	Q—quit

Every time you enter a command, you move to another room or get a different perspective of your location in the room. The rooms look nearly identical, except for the

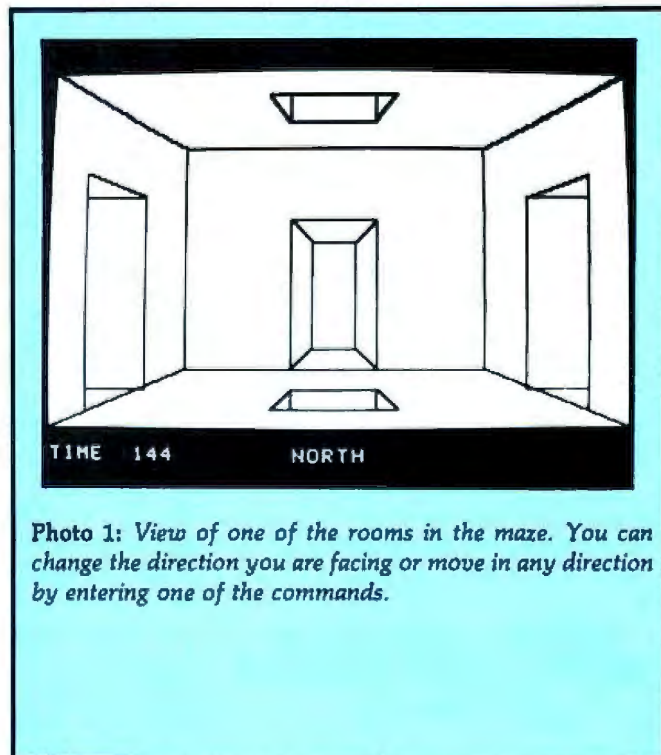

Photo 1: View of one of the rooms in the maze. You can change the direction you are facing or move in any direction by entering one of the commands.

varying positions of the doors and holes in the floor or ceiling. As you move about the maze, the computer ticks off the seconds, keeping track of your total time. The elapsed time is displayed in the lower left-hand corner of the screen.

When you enter the F command, to change your direction, the program asks that you enter the new direction.

**Listing 1: Quinti-Maze.** *written in Applesoft BASIC, requires an Apple II with 32K bytes of memory and one disk drive.*



If you enter the Q command, to stop the game, the program asks if you want to save the current maze. If you do, the program requests a name for the maze and then saves it on the disk. When you next play Quinti-Maze, the program asks if you want to start in a new maze or recall an old maze from the disk. If you want to recall an old maze, you enter the name of the maze. The program returns you to the same room and with the same cumulative time as when you last quit the game.

### Strategy

The strategy for Quinti-Maze is fairly simple; be methodical. Because all the rooms in the maze look similar, you could wander around forever without finding the exit. My favorite method is to travel in one direction for as far as I can go, then I assume I'm at one of the outside walls and search there for an exit.

### Conclusion

Quinti-Maze is a simple yet very playable game. Because it is written in BASIC you can easily modify the program to include your own special features. A denizen or two would add even more excitement to Quinti-Maze. ■

*The author has offered to make copies of his program available to BYTE readers for \$5. Send a blank disk and a self-addressed stamped envelope to:*

*Robert Tsuk  
17 Lexington Ave.  
Plattsburgh, NY 12901*

```

1 DATA 201,84,208,15,32,177,0,3
  2,248,230,138,72,32,183,0,20
  1,44,240,3,76,201,222,32,177
  ,0,32,248,230
2 FOR I = 768 TO 833: READ P: POKE
  I,P: NEXT I
3 DATA 104,134,3,134,1,133,0,17
  0,160,1,132,2,173,48,192,136
  ,208,4,198
4 DATA 1,240,7,202,208,246,166,
  0,208,239,165,3,133,1,198,2,
  208,241,96
5 POKE 1013,76: POKE 1014,0: POKE
  1015,3
10 TEXT : HOME
90 GOSUB 2000
100 DIM FC(5,7): DIM FC$(5)
105 FC$(1) = "NORTH":FC$(2) = "SO
  UTH":FC$(3) = "EAST":FC$(4) =
  "WEST"
110 FOR B = 1 TO 4: FOR I = 1 TO
  6: READ FC(B,I): NEXT : NEXT

115 GOTO 155
120 HPLOT 0,0 TO 279,0 TO 279,15
  9 TO 0,159 TO 0,0 TO 69,29 TO
  209,29 TO 209,129 TO 69,129 TO
  69,29: HPLOT 209,29 TO 279,0
  : HPLOT 209,129 TO 279,159: HPLOT
  69,129 TO 0,159: RETURN
125 RETURN
130 HPLOT 109,9 TO 169,9 TO 159,
  19 TO 119,19 TO 109,9: HPLOT
  119,19 TO 119,9: HPLOT 159,1
  9 TO 159,9: RETURN
135 HPLOT 119,139 TO 159,139 TO
  169,149 TO 109,149 TO 119,13
  9: HPLOT 119,139 TO 119,149:
  HPLOT 159,139 TO 159,149: RETURN
140 HPLOT 19,39 TO 49,49 TO 49,1
  39: HPLOT 19,149 TO 19,39: HPLOT
  19,139 TO 49,139: HPLOT 19,4
  9 TO 49,49: RETURN
145 HPLOT 119,59 TO 159,59 TO 15
  9,129 TO 119,129 TO 119,59 TO
  129,69 TO 149,69 TO 149,119 TO
  129,119 TO 129,69: HPLOT 149
  ,69 TO 159,59: HPLOT 149,119
  TO 159,129: HPLOT 129,119 TO
  119,129: RETURN
150 HPLOT 229,49 TO 259,39 TO 25
  9,149: HPLOT 229,139 TO 229,
  49: HPLOT 229,49 TO 259,49: HPLOT
  229,139 TO 259,139: RETURN
155 DIM S$(6,6)
160 INPUT "RESTART OLD MAZE ":Y$
  : IF LEFT$(Y$,1) = "Y" THEN
  1360
165 FOR A = 1 TO 5: FOR X = 1 TO
  5: FOR Y = 1 TO 5
167 & T10 * A + 10 * X + 10 * Y,
  10

```

*Listing 1 continued on page 26*

# SUPPLIES!

## BASF DISKETTES, 100% CERTIFIED

Stk #	5.25" DISKETTES, BOX OF 10	1 BOX	5	10+
35-256	1 SIDE SINGLE DENSITY SOFT SECTOR	\$23.00	\$112.50	\$220.00
35-257	1 SIDE SINGLE DENSITY 10 SECTOR	\$23.00	\$112.50	\$220.00
35-648	1 SIDE DOUBLE DENSITY SOFT SECTOR	\$24.00	\$117.50	\$230.00
35-649	1 SIDE DOUBLE DENSITY 10 SECTOR	\$24.00	\$117.50	\$230.00
35-624	2 SIDE DOUBLE DENSITY SOFT SECTOR	\$38.00	\$185.00	\$360.00
35-627	2 SIDE DOUBLE DENSITY 10 SECTOR	\$38.00	\$185.00	\$360.00
Stk #	5" DISKETTES, BOX OF 10	1 BOX	5	10+
38-426	1 SIDE SINGLE DENSITY SOFT SECTOR	\$24.00	\$117.50	\$230.00
38-568	1 SIDE DOUBLE DENSITY SOFT SECTOR	\$35.00	\$170.00	\$330.00
38-596	1 SIDE DOUBLE DENSITY 32 SECTOR	\$35.00	\$170.00	\$330.00
38-325	2 SIDE DOUBLE DENSITY SOFT SECTOR	\$43.00	\$207.50	\$410.00
38-812	1 SIDE SINGLE DEN. (SHUGART 32 SECT)	\$24.00	\$117.50	\$230.00

## HARDHOLES — ADDED STRENGTH REINFORCING RINGS PREVENT HOLE TEARING AND RIPPING DAMAGE. MADE OF HEAVY DUTY MYLAR.

Stk #	Price
29-801	6" APPLICATION KIT ..... \$11.95
29-800	EXTRA BOXES OF 50 HOLES ..... \$8.00
29-501	5" APPLICATION KIT ..... \$8.95
29-500	EXTRA BOXES OF 50 HOLES ..... \$8.00



## DISK DRIVE HEAD CLEANING KITS — REDUCE READ/WRITE ERRORS AND EXTEND MEDIA LIFE WITH REGULAR CLEANING.

Stk #	Price
21-731	Box of three 8" disks ..... \$35.00
21-732	Box of three 5" disks ..... \$35.00
	<b>PERFECT DATA™ one/two head kit.</b>
21-708	8" Cleaning kit ..... \$24.95
21-705	5.25" Cleaning kit ..... \$24.95

## Flip 'N' File™

PROTECTIVE STORAGE SYSTEM FOR UP TO 60 DISKS. TRANSPARENT SMOKE COLORED ACRYLIC CONSTRUCTION WITH HINGED LID AND INDEX DIVIDERS.

Stk #	Price
25-805	FOR 5" DISKS ..... \$24.95
25-808	FOR 8" DISKS ..... \$29.95



Stk #	EACH	TEN	CASE
21-105	\$2.95	\$2.25ea	\$CALL
21-108	\$3.95	\$2.95ea	\$CALL

## Paper Tractor



THE PAPER TRACTOR ENABLES YOUR TRACTOR FEED SYSTEM TO FEED INDIVIDUAL SHEETS OF LETTER OR LEGAL SIZE PAPER... INEXPENSIVELY!

- Fits 9 1/2" print frames
  - Compatible with matrix, impact, daisywheel and ink injection printheads
  - Fits front, back and dual tractor feeds
  - Proven with all major manufacturers printers including Epson, Tiger, DEC-writer, Commodore, Centronics, RS V VI VII and many more
- Stk # 28-1101 ..... \$14.95

## RIBBONS — QUALITY, BRAND NEW, LONG LIFE EXACT REPLACEMENT

Stk #	Fits these printers	1-5	6-11	12+
41-421	Centronics 700 series, LP, I, II, IV (zip pack insert)	\$3.74	\$3.33	\$2.93
41-430	NEC Spinwriter 5500,7700 multistrike	\$5.84	\$5.20	\$4.57
41-485	Centronics 104	\$20.83	\$18.58	\$16.32
41-471	Diablo HY Type II, Multistrike	\$4.85	\$4.32	\$3.80
41-473	Diablo HY Type II, Long life nylon fabric	\$5.38	\$4.80	\$4.22
41-476	QUME, Multistrike black	\$3.88	\$3.42	\$3.00
41-495	Texas Instr. 810, Dual Spools	\$5.06	\$4.52	\$3.97
41-496	Decwriter LA 30/36, Dual spools	\$4.91	\$4.38	\$3.85
41-498	DEC LA 180, TI 820 dual spools	\$6.61	\$5.90	\$5.18
41-451	Epson/IBM MX 70/80 cartridge	\$13.82	\$12.33	\$10.83

## THE SOURCE

America's information utility. Get timely information on stocks, bonds, commodities. Find Airline schedules and make travel reservations. Use the discount shopping and banner service. Many other facilities available.

Stk. # 965 The Source Electronic Information and Communication Service \$85.00

# (805)985-9824

BY MAIL: Mail your order to NATIONAL DATA SUPPLIES, INC. 1741 CAPSTAN DRIVE OXNARD, CA 93033

Include your phone number, Master Card or Visa number, and expiration date. Please order by stock number. Minimum order \$20.00. C.O.D.s 3% (min \$2.00).

Personal checks require two weeks to clear.

**PURCHASE ORDERS:** Purchase orders welcome from well rated companies and institutions. Minimum order \$35.00

**SHIPPING:** 3% of order (minimum \$3.00). Non UPS areas, export orders or parcel post are 10% (minimum \$5.00).

# INDS NATIONAL DATA SUPPLIES, INC.

Listing 1 continued:

```

170 IF A < > 5 AND RND (1) < .
    BO THEN S$(X,A) = S$(X,A) +
    "0": GOTO 180
175 S$(X,A) = S$(X,A) + "X"
180 IF MID$(S$(X,A - 1), (Y - 1
) * 6 + 1, 1) = "0" THEN S$(X
,A) = S$(X,A) + "0": GOTO 19
0
185 S$(X,A) = S$(X,A) + "X"
190 IF Y - 2 < 0 THEN 200
195 IF MID$(S$(X,A), (Y - 2) *
6 + 4, 1) = "0" THEN S$(X,A) =
S$(X,A) + "0": GOTO 205
200 S$(X,A) = S$(X,A) + "X"
205 IF Y < > 5 AND RND (1) < .
    8 THEN S$(X,A) = S$(X,A) + "
0": GOTO 215
210 S$(X,A) = S$(X,A) + "X"
215 IF X < > 5 AND RND (1) < .
    8 THEN S$(X,A) = S$(X,A) + "
0": GOTO 225
220 S$(X,A) = S$(X,A) + "X"
225 IF MID$(S$(X - 1,A), (Y - 1
) * 6 + 5, 1) = "0" THEN S$(X
,A) = S$(X,A) + "0": GOTO 23
5
230 S$(X,A) = S$(X,A) + "X"
235 NEXT : NEXT : NEXT
240 X = INT ( RND (1) * 3) + 2:Y
    = INT ( RND (1) * 3) + 2:A
    = INT ( RND (1) * 3) + 2
245 RD = INT ( RND (1) * 6) + 1:
    ON RD GOTO 250,255,260,265,
    270,275
250 A = 5:P1$ = LEFT$(S$(X,A), (
Y - 1) * 6):L = 29 - LEN (P
1$):P2$ = RIGHT$(S$(X,A),L
):S$(X,A) = P1$ + "0" + P2$:
    GOTO 280
255 A = 1:P1$ = LEFT$(S$(X,A), (
Y - 1) * 6 + 1):L = 29 - LEN
(P1$):P2$ = RIGHT$(S$(X,A)
,L):S$(X,A) = P1$ + "0" + P2
$: GOTO 280
260 Y = 5:P1$ = LEFT$(S$(X,A), (
Y - 1) * 6 + 3):L = 29 - LEN
(P1$):P2$ = RIGHT$(S$(X,A)
,L):S$(X,A) = P1$ + "0" + P2
$: GOTO 280
265 Y = 1:P1$ = LEFT$(S$(X,A), (
Y - 1) * 6 + 2):L = 29 - LEN
(P1$):P2$ = RIGHT$(S$(X,A)
,L):S$(X,A) = P1$ + "0" + P2
$: GOTO 280
270 X = 5:P1$ = LEFT$(S$(X,A), (
Y - 1) * 6 + 4):L = 29 - LEN
(P1$):P2$ = RIGHT$(S$(X,A)
,L):S$(X,A) = P1$ + "0" + P2
$: GOTO 280
275 X = 1:P1$ = LEFT$(S$(X,A), (
Y - 1) * 6 + 5):L = 29 - LEN
(P1$):P2$ = RIGHT$(S$(X,A)
,L):S$(X,A) = P1$ + "0" + P2
$: GOTO 280
280 SX = X:SY = Y:SA = A
    
```

Listing 1 continued on page 28

# QUME

**SPECIAL SALE  
SPRINT 9/45!  
Call Qume for details.**

## SPRINT 9

STANDARD OPERATOR  
CONTROL PANEL.

Switch selection of interface parameters and forms handling allows simple OEM system integration.

Automatic proportional spacing, without decreasing system throughput, sets the new standard for print quality.

To cut service costs and reduce adjustments, the exclusive Kevlar® belt is stronger and lighter than steel, with virtually no stretch.

For the highest accuracy in the history of daisywheel printing, our Microdrive™ carriage drive mechanism has no cables or pulleys.

## Test drive our hot new daisywheelers.

If you've always wanted letter-quality printing from your DP system but the cost has put you off, then a SPRINT 9 is for you. Now you can have the same high quality print—usually only available on word processing systems—at prices that will let you forget all about dot-matrix terminals. With speeds of 45 and 55 cps (average English text, not burst rate), the reliable high performance of SPRINT 9 terminals leaves the crowd behind. Prove it to yourself with a test drive. Call or write Qume at (408) 942-4000, 2350 Qume Drive, San Jose, California 95131.

LIMITED OEM  
CONTROL PANEL.

**Qume.**  
A Subsidiary of ITT

# TRS-80™ By RADIO SHACK

1-800-841-0860 Toll Free

**BUY DIRECT**  
PURE RADIO SHACK EQUIPMENT  
**LOW DISCOUNT PRICES**

TRS-80 Color Computer



BUY DIRECT

PRICED FROM

**\$299**

TRS-80 Model II Computer



BUY DIRECT

PRICED FROM

**\$2988**

TRS-80 Model III Computer



BUY DIRECT

PRICED FROM

**\$609**

TRS-80 Model 16 Computer



BUY DIRECT

PRICED FROM

**\$4158**

Smith Corona TP-1 Daisy Wheel Printer



BUY DIRECT

\*LIST \$895.00\*

**\$639**

Commodore  
**VIC-20**  
The Friendly Computer

**\$249**

TM - TANDY CORPORATION  
FREE COPY OF WARRANTY  
UPON REQUEST

CENTRONICS 739-1  
**\$469**

WRITE FOR YOUR FREE CATALOG

We Carry The Full TRS-80 Product Line

**MICRO MANAGEMENT SYSTEMS, INC**

PARCEL DIVISION - DEPT. NO. 1

2803 Thomasville Road East

Cairo, Georgia 31728

GA. & INFO 912-377-7120

SMITH-CORONA

VIC-20  
The Friendly Computer

Thousands of Satisfied Customers Since '78

Listing 1 continued:

```

290 VTAB 23: PRINT "HIT ANY KEY
    TO START"
300 IF PEEK ( - 16384) < 127 THEN
    300
310 POKE - 16368,00
1000 X = INT ( RND (1) * 5) + 1:
    Y = INT ( RND (1) * 5) + 1:
    A = INT ( RND (1) * 5) + 1:
    FC = 1: GOTO 1220
1010 HOME : VTAB 22: HTAB 18: PRINT
    FC$(FC):A$ = "":D = 0: IF LS
    = 1 THEN PRINT X,Y,A
1020 VTAB 22: PRINT "TIME :";T: FOR
    TIME = 1 TO 80
1025 IF PEEK ( - 16384) > 127 THEN
    1030
1027 NEXT :T = T + 1: VTAB 22: PRINT
    "TIME :";T: GOTO 1020
1030 GET A$
1035 IF A$ = "*" THEN LS = 1
1040 IF A$ = "Q" THEN LS = 1300
1050 IF A$ = "U" THEN D = 1
1060 IF A$ = "D" THEN D = 2
1070 IF A$ = "N" THEN D = 3
1080 IF A$ = "S" THEN D = 4
1090 IF A$ = "E" THEN D = 5
1100 IF A$ = "?" THEN LS = 1290
1110 IF A$ = "W" THEN D = 6
1120 IF A$ = "F" THEN GOTO 1280

1130 IF D = 0 THEN 1010
1135 T = T + 1
1140 IF MID$(S$(X,A),(Y - 1) *
    6 + D,1) < "0" THEN PRINT
    CHR$(7): GOTO 1010
1150 ON D GOTO 1160,1170,1180,11
    90,1200,1210
1160 A = A + 1: GOTO 1220
1170 A = A - 1: GOTO 1220
1180 Y = Y - 1: GOTO 1220
1190 Y = Y + 1: GOTO 1220
1200 X = X + 1: GOTO 1220
1210 X = X - 1: GOTO 1220
1220 IF X > 5 OR X < 1 OR Y > 5 OR
    Y < 1 OR A > 5 OR A < 1 THEN
    PRINT "YOU WIN": & T100,100
    : & T100,50: & T100,50: & T7
    5,66: & T100,66: & T75,66: &
    T60,255: GOTO 3000
1230 HGR : HCOLOR= 3: HPL0T 0,0:
    CALL 62454: HCOLOR= 0: GOSUB
    120
1240 FOR I = 1 TO 6: IF MID$(S
    $(X,A),(Y - 1) * 6 + I,1) =
    "X" THEN NEXT : GOTO 1010
1250 R = FC(FC,I) + 1
1260 HCOLOR= 0: ON R GOSUB 125,1
    30,135,140,145,150
1270 NEXT : GOTO 1010
1280 INPUT "WHAT FACING 1-N 2-S
    3-E 4-W";FC: IF FC < 1 OR FC
    > 4 THEN 1280
1285 GOTO 1220
1290 INVERSE : HTAB 18: PRINT SX
    ;" ";SY;" ";SA: NORMAL : GOTO
    1220
    
```

Listing 1 continued on page 30

# The software professional's choice.

The most complete Pascal programming package is available for both 8 and 16-bit computers. Pascal/MT+ is the choice of professional software writers and hardware vendors. Pascal/MT+ is fast, versatile, and portable, plus it's easier to use than other Pascals. In fact, no other Pascal gives you the many programming conveniences of Pascal/MT+. Our superior native code compiler, 8087 support, advanced debugging tools, and ROM-able code make it perfect for every professional application. Pascal/MT+ is a total development package with all the utilities you need, including our

exclusive SpeedProgramming Package.<sup>®</sup> Pascal/MT+ is a comprehensive language package that translates directly into high-speed object code, not slow P-code. That means it's five to ten times faster than the competition's. So move up to the best Pascal on the market.

Call or write Digital Research for more information. (408) 649-5500 or (408) 649-3896. 160 Central Ave., Pacific Grove, California 93950.



**DIGITAL  
RESEARCH™**

The creators of CP/M™

Circle 184 on Inquiry card.

#### Europe

Vector International Research Park  
B-3030 Leuven, Belgium  
32 (16) 20-24-96  
Telex: 26202 VECTOR

#### Far East

Microsoftware Associates  
6 Floor A.Y. Building  
3-2-2 Kitaoyama, Minato-ku  
Tokyo 107, Japan  
03-403-2120  
Telex: 2426875



# Pascal/MT+™

Listing 1 continued:

```

1300 PRINT "DO YOU WANT TO SAVE
THIS MAZE": INPUT Y$: IF LEFT$(
(Y$,1) < > "Y" THEN GOTO 3
000
1310 INPUT "WHAT DO YOU WANT TO
CALL IT ";N$
1320 D$ = CHR$(4)
1330 PRINT D$;"OPEN OLD MAZE/";N
$: PRINT D$;"WRITE OLD MAZE/
";N$
1340 FOR A1 = 1 TO 5: FOR X1 = 1
TO 5: PRINT S$(X1,A1): NEXT
: NEXT : PRINT X: PRINT Y: PRINT
A: PRINT T: PRINT FC
1350 PRINT D$;"CLOSE OLD MAZE/";
N$: GOTO 3000
1360 INPUT "WHAT IS ITS NAME ";N
$
1370 D$ = CHR$(4)
1380 PRINT D$;"OPEN OLD MAZE/";N
$: PRINT D$;"READ OLD MAZE/"
;N$
1390 FOR A1 = 1 TO 5: FOR X1 = 1
TO 5: INPUT S$(X1,A1): NEXT
: NEXT : INPUT X: INPUT Y: INPUT
A: INPUT T: INPUT FC
1400 PRINT D$;"CLOSE OLD MAZE/";
N$: GOTO 1220
2000 VTAB 12: HTAB 18: INVERSE :
PRINT "MAZE": NORMAL : VTAB
22: INPUT "DO YOU WANT INSTR
UCTIONS ";Y$: IF LEFT$(Y$,
1) < > "Y" THEN RETURN
2005 PR# 1
2010 HOME : PRINT "THE OBJECT OF
MAZE IS TO FIND YOUR WAY": PRINT
: PRINT "OUT OF A 5X5X5 CUBI
C MAZE. IN ONE OF THE": PRINT
"ROOMS THERE IS AN EXIT OUT
OF THE MAZE."
2020 PRINT : PRINT "YOU MUST TRY
TO FIND IT IN AS FEW TURNS
": PRINT "AS POSSIBLE. THE C
OMMANDS ARE : "
2030 PRINT : HTAB 6: INVERSE : PRINT
"U";: NORMAL : PRINT "--UP";:
HTAB 17: INVERSE : PRINT "S
";: NORMAL : PRINT "--SOUTH"
2040 PRINT : HTAB 6: INVERSE : PRINT
"D";: NORMAL : PRINT "--DOWN"
;: HTAB 17: INVERSE : PRINT
"E";: NORMAL : PRINT "--EAST"
2050 PRINT : HTAB 6: INVERSE : PRINT
"N";: NORMAL : PRINT "--NORTH
";: HTAB 17: INVERSE : PRINT
"W";: NORMAL : PRINT "--WEST"
2060 PRINT : HTAB 6: INVERSE : PRINT
"Q";: NORMAL : PRINT "--QUIT"
;: HTAB 17: INVERSE : PRINT
"F";: NORMAL : PRINT "--CHANG
E FACING"
2070 VTAB 23: PRINT "HIT ";: INVERSE
: PRINT "SPACE";: NORMAL : PRINT
" FOR MORE"
2080 IF PEEK ( - 16384) < 127 THEN
2080
2090 POKE - 16388,0: HOME : INVERSE
: PRINT "F";: NORMAL : PRINT
" WILL COME BACK WITH A QUES
TION AS TO": PRINT : PRINT "
WHICH FACING YOU WISH.HIT ON
LY ONE KEY": PRINT : PRINT "
AND ";: INVERSE : PRINT "RET
URN": NORMAL
2100 PRINT : PRINT "PLEASE WAIT
WHILE IT SETS UP THE MAZE": PRINT
: PRINT : RETURN
3000 TEXT : HOME : VTAB 5: HTAB
12: PRINT "CONGRATULATIONS !
"
3010 PRINT : PRINT TAB(7)"YOU
HAVE FINISHED THE MAZE IN ":
PRINT TAB(7)T;" SECONDS"
3030 INPUT "DO YOU WANT TO PLAY
AGAIN ? ";Y$
3040 IF LEFT$(Y$,1) = "Y" THEN
RUN
9999 NORMAL
10000 DATA 1,2,4,0,5,3,1,2,0
,4,3,5,1,2,3,5,4,0,1,2,5,3,0
,4

```

## SEPTEMBER SPECIAL • NEW XEROX 820-II 5 1/4" DD - \$1995\*



FEATURES: 4MHz Z80A, CP/M BASED, 64K RAM, DD DISK CONTROLLER, THIN LINE GRAPHICS, ENHANCED SCREEN FEATURES, H.L INTENSITY, REVERSE VIDEO, TONE GENERATOR, 2 RS-232 PORTS, ONE PARALLEL PRINTER PORT, ALSO BOOTS AS INTELLIGENT TERMINAL.

**\$199 OPTION PACKAGE for any 820/820 II**

- 280SPEEDUP - Programmable to 6MHz (Simple plug-in resolution) \$149
- DISPLAY RISER - Elevates 3" or 5", Steel Construction \$ 20
- ACRYLIC GREEN SCREEN - Mated to 9" CRT \$ 19
- NYLON ANTI-GLARE SCREEN - Stretches over CRT \$ 19
- SYSTEM DUST COVERS - 3 Covers Protect CRT, Drives & Keyboard \$ 20

**\$299 OPTION PACKAGE for any 820/820 II**

- INCLUDES ALL OF THE \$199 PACKAGE PLUS - \$ 25
- Box of 10 Disquettes
- Surge-Protected Multiple Outlet Strip (5 outlets, circuit breaker, on/off, light) \$ 19
- Enter Key for Numeric Keypad \$ 19
- Coating fan fits in display processor, quiet \$ 35
- Parallel Printer Cable \$ 19

**\$299 820 DD Kit**

- 250% More Storage than Model 820
- Simple Plug-In Installation

All options available separately — PLUS ADDITIONAL SAVINGS on other Hardware & Software!

\*PRICE INCLUDES THE NEW XEROX 820 II DISPLAY/PROCESSOR, KEYBOARD and 2 TANDON DRIVES. FULL MANUFACTURER'S WARRANTY

### XEROX 820 II SYSTEMS

5 1/4" SS/DD - \$1995\*  
5 1/4" DS/DD - \$2495\*  
8" SS/DD - \$2995\*

Similar savings on:  
8" DS/DD & Hard Drive Systems\*

## microNEST

Box 545, 1700 Front Street  
Fort Benton, MT 59442  
CALL COLLECT TO ORDER:  
(406) 622-5651 9-5, MDT, M-F

VISA, MC, Cash, CK, MO, COD: Add 2% for Ship. Handling/Ins. UPS. Order Hours 9-5 MDT, M-F.

XEROX 820/820 II are trademarks of Xerox Corp. CP/M is a trademark of the Digital Research Corp.





# The \$1795. Personal Business Computer that is changing the way people go to work.

Henry Ford revolutionized personal transportation.

Adam Osborne has done the same for personal business computing.

Virtually everything you need in a personal business computer to work faster and better with words, numbers, and ideas is included in a portable carrying case you can take anywhere.

The Osborne is easy to learn, fun to use, and quickly becomes indispensable.

One price, \$1795, buys it *all*. The Osborne is available from a computer retailer near you.

And you can buy it in any color you want. As long as it is blue.

Put away your buggywhips.



**\$1795. Complete. Including Software.**

For your nearest dealer, call (in California) 800 772-3545 ext. 905; (outside California) call 800 227-1617 ext. 905.

**OSBORNE**  
COMPUTER CORPORATION™

The \$1795 suggested retail price for the Osborne 1 (a trademark of Osborne Computer Corporation) includes a full business keyboard, built-in CRT display, two built-in floppy disk drives, CPU and 64 kilobytes of RAM memory, RS-232 and IEEE 488 interfaces, and the following software packages: WORDSTAR® word processing with MAILMERGE® (a trademark and a registered trademark of MicroPro International Corporation of San Rafael, California); SUPERCALC® electronic spreadsheet system (a trademark of Sorcim Corporation); CBASIC® (a registered trademark of Compler Systems); MBASIC® (a registered trademark of Microsoft); and CP/M® (a registered trademark of Digital Research).

# When you say your disk drive has more juice than Apple's, be prepared to cut one open.

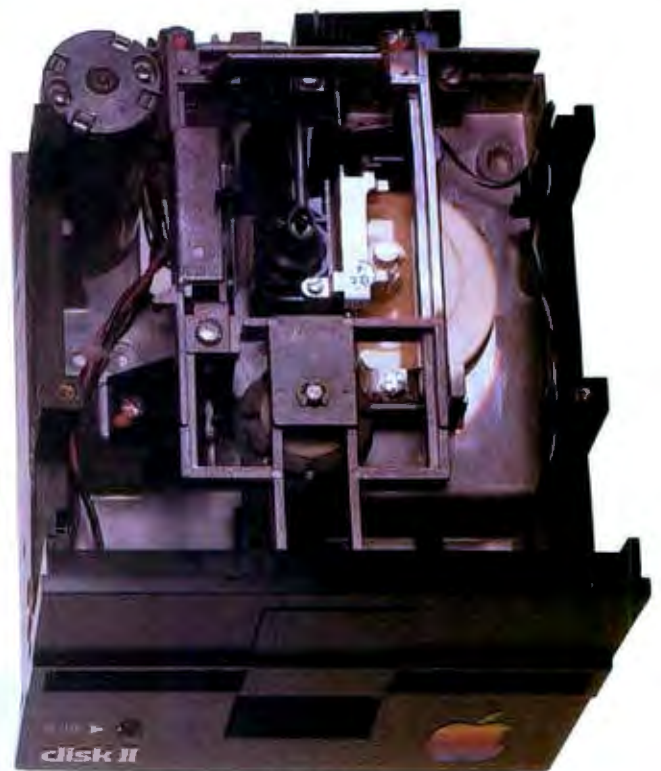

## The problem with Apple's disk drive stems from the core.

There are a lot of good reasons why dealers all over America aren't recommending Apple's disk drive. And one of the main reasons is Rana Systems' new Elite Series of Apple II compatible disk drives.

It's easy to see why Apple® has been having some major slipped disk problems. Just look at their antiquated head positioner.

It's plastic. Just like a toy. That's why it can take multiple passes to get the information needed. And why the information on your disk can appear obscured and unreadable. If Apple's positioner doesn't accurately center the head over your data tracks, it's no bargain at any price.

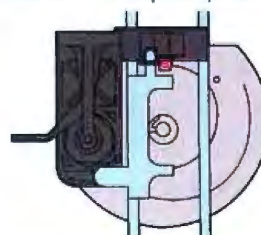

Apple's primitive plastic positioner  
A workable, but sloppy, way to capture data.

Rana knows the head positioner is the heart of the machine, so we didn't cut any corners. To most accurately place the head over the data area we use finely machined lead screws and metal band positioners. They provide you with the fastest and clearest data recognition on the market. With three to four times faster access, track to track. With far greater precision than Apple's, to give you virtually 100% data integrity.

Rana's state of the art technology lead screw and metal band positioners give vastly improved speed and accuracy.

access, track to track. With far greater precision than Apple's, to give you virtually 100% data integrity.

### More juice on Apple's inferiority.

There's another big problem Apple has chosen to ignore. The irritating scratching noise that occurs when it is searching for information. Rana, on the other hand, has built the Elite Series to be virtually noiseless.

And more importantly, Rana has an advanced write protect feature which makes it impossible to lose your information. A simple touch on the front panel's membrane switch gives you failsafe control. Apple of course only has a notch or tab, which gives you only minimal protection.

With the superior Elite controller card, you can control up to four floppy disks using only one slot. With Apple's you can only use two. Of course, you can still plug into Apple's controller card, but down the line you'll want to switch to Rana's and save yourself a slot.

### Elite also gives you more byte per buck.

Even our most economical model, the Elite One, gives you 14% more storage than Apple's. 163K versus Apple's 143K. With our Elite Two offering 326K and our top-of-the-line Elite Three offering a 356% storage increase at 652K. That's almost comparable to hard disk performance, all because of our high density single and double sided disks and heads.

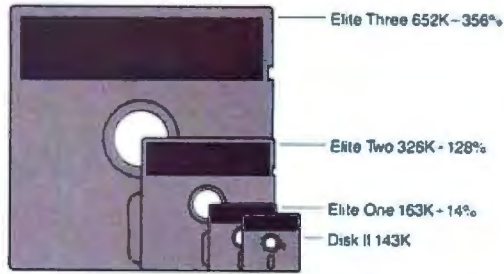

And the cost? Just look at the chart. 272 Bytes per dollar for Apple, versus between 363 to 767 Bytes per dollar for ours. They're not even close.

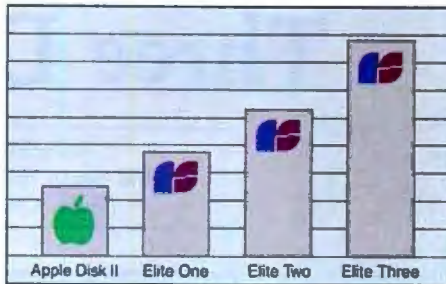

### The real beauty of it isn't the beauty of it.

There is no comparison to the lean, clean design of the Elite Series to Apple's 5 year old model (which by the way has never been updated). It's our superior technology, operating economy, increased storage and faster step that makes us the best performing and hottest selling disk drive in America.

So give us a call or write for more information. It doesn't take a lot of courage to cut into an Apple when you outshine them as brilliantly as we do.

## RanaSystems



20620 South Leapwood Avenue, Carson, CA 90746 213-538-2353. For dealer information call toll free 1-800-421-2207. In California only call: 1-800-262-1221. Source Number: TCT-654

## Three Dee Tee

John Stuart  
6345 South 70th East Ave.  
Tulsa, OK 74133

Three Dee Tee is a computer game for two players, which runs on the Radio Shack TRS-80 Color Computer. It is loosely based on the Rubik's cube game and Tic Tac Toe. The object of the game is to color three cubes in a line either vertically, horizontally, or diagonally. The computer keeps track of every winning combination and displays a box score for each player.

When you start the program, the computer draws two cubes. One cube is larger than the other and represents the front view. The smaller cube shows the back view of the cube as if viewed in a mirror. After the program generates these two cubes, it draws 9 smaller subcubes on each face. There are 6 faces with 9 subcubes each for a total of 54 subcubes.

Next, the computer colors a subcube for player A. It then starts moving the color cursor around the cube in an orderly fashion. It may take you some time to get oriented to the pattern of movement. Observe that one, two, or three faces can be colored for each subcube, depending on its position. If some of the faces are on the back of the cube, the smaller cube will show the color. Thus, a subcube can be colored on the front view, the back view, or both.

The cursor starts at the subcube 1 corner of the cube (see figure 1).

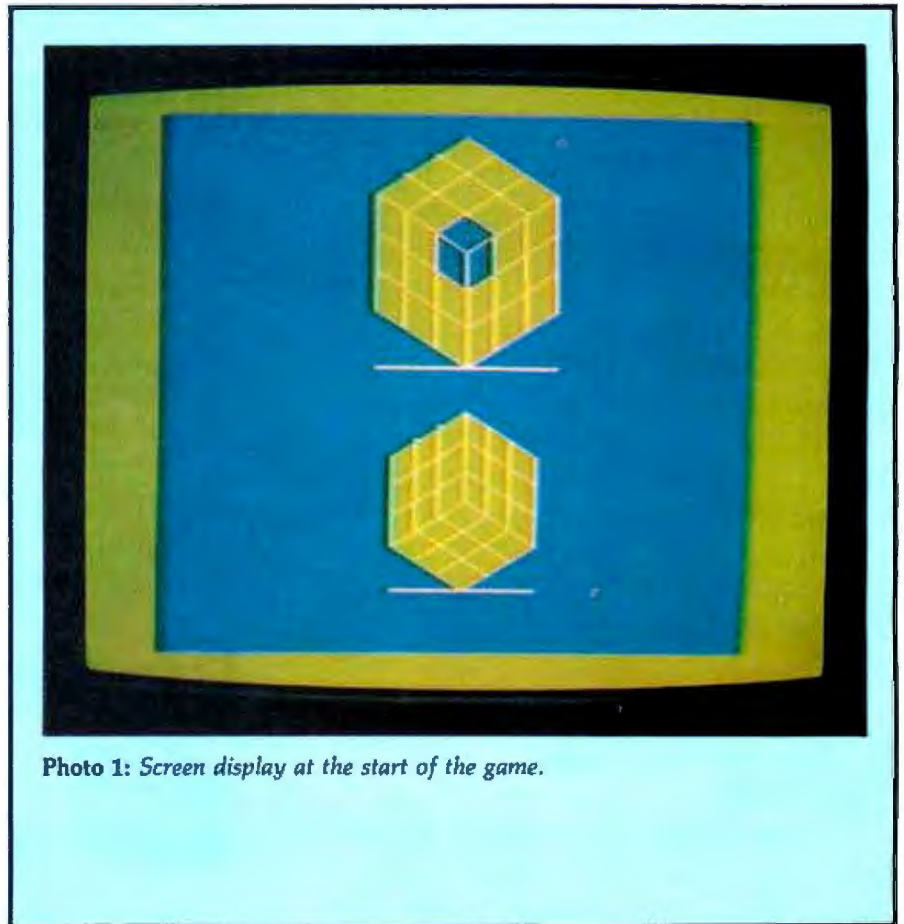

Photo 1: Screen display at the start of the game.

Photo 1 shows the view at the start of the game. The cursor moves along each row of the cube, coloring each of 27 subcubes in turn; the center one is skipped, so it takes 26 moves to traverse the entire cube. When

player A presses any key, the subcube is permanently colored, and player B's color then starts moving around the cube. If a straight line of three subcubes together in a player's color are made, then a point is recorded in



the player's column. The winner is the player who has the highest box score when all subcubes are colored.

### Program Design

Initially, I intended to rotate one cube on the screen and let the players move the cursor using joysticks, but several problems forced me to abandon this approach. The mathematics involved in rotating the cube in order to give a three-dimensional effect got very complicated for someone who had managed to avoid trigonometry in school. Even when I developed a BASIC program that would crudely represent an object rotating in space, it was too slow to give the appearance of a smooth rotation. Therefore, I decided to take the approach of displaying the front and back of a cube.

I organized the program to do the following major tasks:

- draw the cube views
- move the cursor around the sub-cubes for each player
- build a win table of all winning combinations
- check each player's move against the win table, and display the score

The flowchart explains the logic of the program routines that accomplish these tasks (see figure 2).

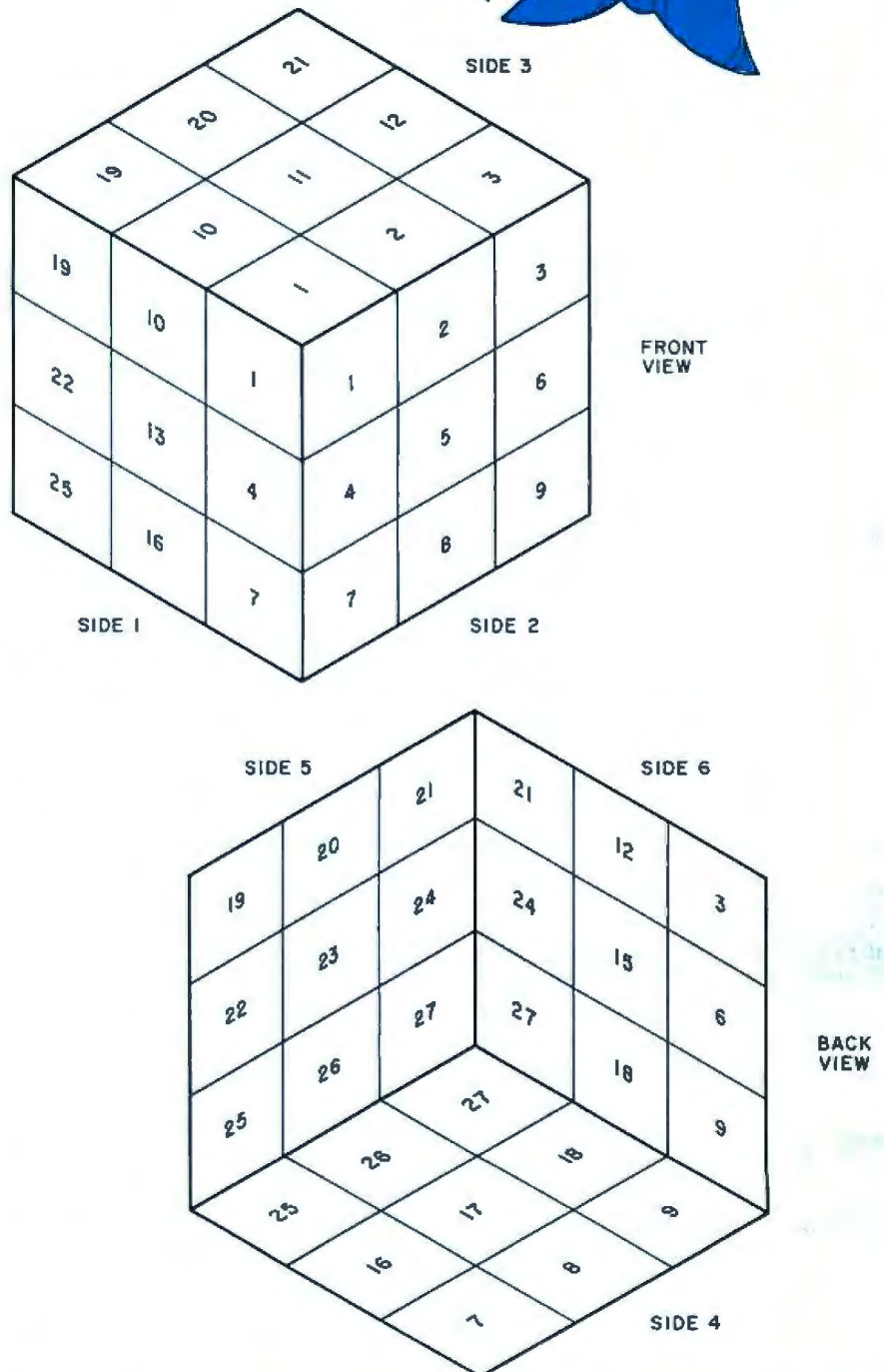

Figure 1: Numbering scheme used by the program to determine the position of the cursor.

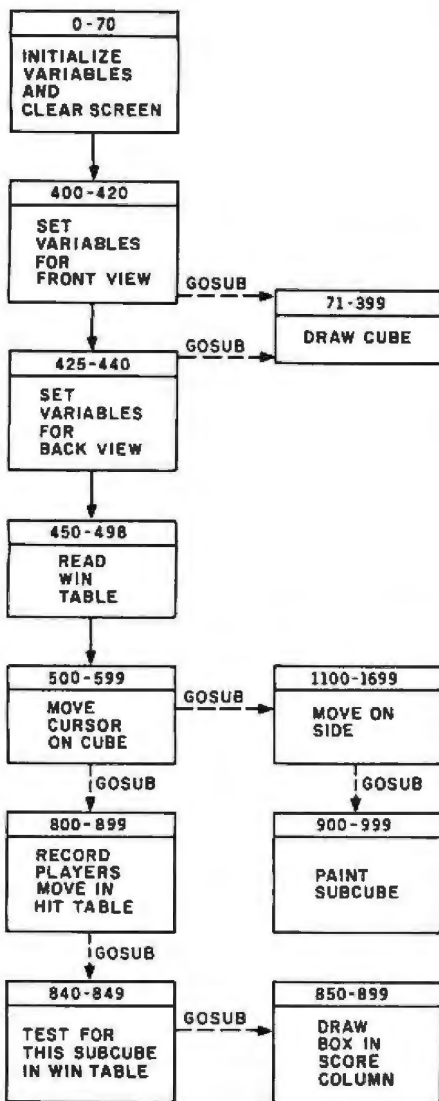

Figure 2: Flowchart of the Three Dee Tee program.

## Drawing the Cubes

The subroutine at line 71 is used to draw the cubes (see listing 1). This subroutine is written so that it can be changed to draw different size cubes at different locations on the screen. The instructions at lines 400-420 set the size and location for the front view of the cube, and lines 425-440 change the size and location for the back view of the cube.

First, the subroutine at line 71 computes the variables used to draw the cube using the size and location set by the calling routine. See figure 3 and table 1 for an explanation of these variables. The instructions at lines 100-399 then use these variables in Line commands to draw the different

Text continued on page 45

Listing 1: Three Dee Tee runs on the TRS-80 Color Computer and requires 16K bytes of memory.

```

1 REM 3DT GAME COPYRIGHT
2 REM 1981 JOHN C STUART
5 CLEAR 100
10 PCLEAR 4
20 PMODE 3,1
30 B=3:F=2
31 P=1
32 AS=180:BS=180
33 PA=3:PB=4
34 PN=PA
40 COLOR F,B
50 SCREEN 1,0
51 PCLS B
54 DIM WN(48,3)
55 DIM CC(27)
56 FOR BN=1 TO 27
58 CC(BN)=1
60 NEXT BN
62 BN=0
69 GOTO 400
70 REM COMP CUBE VARIABLES
71 X1=X/3
72 X2=X*2/3
81 LC=H-2*X
82 MC=H
83 RC=H+2*X
84 V1=V-2*X
85 V2=V-X
86 V3=V
87 V4=V+X
88 V5=V+2*X
100 REM DRAW CUBE
110 LINE(MC,V3)-(MC,V5),PSET
120 LINE(MC,V5)-(RC,V4),PSET
125 LINE(RC,V4)-(RC,V2),PSET
130 LINE(RC,V2)-(MC,V3),PSET
135 LINE(MC,V3)-(LC,V2),PSET
140 LINE(LC,V2)-(LC,V4),PSET
145 LINE(LC,V4)-(MC,V5),PSET
150 LINE(LC,V2)-(MC,V1),PSET
155 LINE(MC,V1)-(RC,V2),PSET
200 PAINT(H-D,V),P,F
205 PAINT(H+D,V),P,F
210 PAINT(H,V-D),P,F
300 LINE(LC,V+X1)-(MC,V+2*X2),PSET
305 LINE(LC,V-X1)-(MC,V+X2),PSET
310 LINE(RC,V+X1)-(MC,V+2*X2),PSET
315 LINE(RC,V-X1)-(MC,V+X2),PSET
320 LINE(LC+X2,V-X2)-(LC+X2,V+X+X1),PSET
325 LINE(MC-X2,V-X1)-(MC-X2,V+X+X2),PSET
330 LINE(MC+X2,V-X1)-(MC+X2,V+X+X2),PSET
335 LINE(RC-X2,V-X2)-(RC-X2,V+X+X1),PSET
340 LINE(LC+X2,V-X2)-(MC+X2,V-X-X2),PSET
345 LINE(MC-X2,V-X1)-(RC-X2,V-X-X1),PSET
350 LINE(LC+X2,V-X-X1)-(MC+X2,V-X1),PSET
  
```

Listing 1 continued on page 38

# And The Winner Is... IBC By Four Users!



When you are racing toward that finish line, beating the competition is everything. IBC is the choice of OEM's, system integrators and dealers throughout the world, because in benchmark after benchmark our small business computer systems finish first.

We finish first because we are faster, offer higher quality peripherals and can expand our system significantly beyond our nearest competitors. In fact, looking at the chart below, you can quickly see why knowledgeable resellers are choosing IBC.



Circle 225 on Inquiry card.

Join us in the winners circle with high performance equipment and the best dealer plan in the industry. Call or write:

	<b>IBC</b>	<b>ONYX</b>	<b>ALLOS</b>
Oasis Operating System (Max. Users)	9	5	4
CPU Speed (MHz)	6	4	3
Disk Speed I/O (MB/Sec.)	81	65	54
Seek (Milli Sec.)	35	50	65
Cache Disk Memory	Yes	No	No

OUTSIDE THE USA  
**IBC** / Integrated Business Computers

21592 Marilla Street  
 Chatsworth, CA 91311  
 (213) 882-9007 TELEX NO. 215349

WITHIN THE USA  
**IBC** / DISTRIBUTION

4185 Harrison Blvd., Suite 301  
 Ogden, UTAH 84403  
 (801) 621-2294

Listing 1 continued:

```
355 LINE(MC-X2,V-X-X2)-(RC-X2,V-X2),PSET
375 LINE(H-2*ABS(X),V+2*ABS(X))-(H+2*ABS(X),V+2*ABS(X)),PSET
399 RETURN
400 REM DRAW BOXES
401 FH=128
402 BH=128
403 FV=48
404 BV=136
405 D=2
406 FX=20
407 BX=-16
409 X=FX
410 H=FH
415 V=FV
419 REM DRAW FRONT VIEW
420 GOSUB 71
425 V=BV
430 H=BH
435 X=BX
436 D=-2
439 REM DRAW BACK VIEW
440 GOSUB 71
450 BX=BX*-1
460 FOR WC=1 TO 48
462 FOR CN =1 TO 3
465 READ WN(WC,CN)
```

Listing 1 continued on page 40

Circle 469 on Inquiry card.



*Step Up The Pace...  
Higher Technology at Lower Cost.*

- Bell 212 compatible—1200 Baud
- Full duplex
- 120 CPS over any standard phone line

Microprocessor design has invaded the modem world. Our new 1200 baud modems pack Bell 212 compatibility into 10 integrated circuits—by far the lowest parts count of any 212 modem available. The extremely low parts count translates directly into long life, outstanding reliability and low production costs—savings passed on to you in a lower price.

The Micro Link 1200 features originate and answer capability. The Auto Link 1200 includes these features plus auto-answer. Both units are FCC certified for direct connection to the phone lines via a standard RJ11C phone jack and include RS232C, Self-Test, and a one year limited warranty.

Take advantage of higher technology at lower cost. Call for full product specifications and today.

Micro Link 1200 \$449\* Auto Link 1200 \$549\*

\*Suggested list price, quantity one



**U.S. ROBOTICS INC.**

1035 WEST LAKE STREET, CHICAGO, ILLINOIS 60607  
(312) 733-0497



# First, the *IBM Personal Computer*, The Next Step . . .

## Tecmar

The **TECMAR** Expansion series is the first and only, complete line of expansion options available for the IBM Personal Computer.

Now totaling over twenty-five separate options, the **TECMAR** series gives you the broadest range of expansion available for your IBM Personal Computer.



**SYSTEM EXPANSION** with a complete Expansion Chassis providing six additional system slots, a separate power supply and styling that complements the IBM system.

**MEMORY EXPANSION** in 64K, 128K, 192K and 256K Byte increments of Dynamic RAM with parity, 32K Bytes of Static RAM, 32K Bytes of CMOS RAM with battery backup, or up to 128K Bytes of Read Only Memory.

**PRACTICAL EXPANSION** with two Serial ports and one Parallel port on a single board, or a Time of Day calendar with battery backup, a Voice Synthesizer with vocabulary in ROM and phoneme speech generation, even a BSR X10™ device controller for lights and appliances.

**DISK EXPANSION** through the addition of a five or ten megabyte Winchester disk. The disk options come enclosed in the **TECMAR** Expansion Chassis, providing additional expansion slots as well as Winchester disk storage. This approach assures you of unmatched system expandability for nearly any application.

**FUNCTIONAL EXPANSION** is also available with **TECMAR** Speed Disk™ and print Spooling Software that give new functionality to memory options.

**UNMATCHED EXPANSION** for the serious IBM Personal Computer user through these and the many other **TECMAR** Expansion products available through participating **COMPUTERLAND** stores, and other fine computer retailers nationwide.

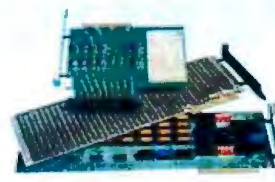
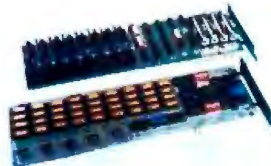

**LABORATORY/INDUSTRIAL EXPANSION** through an IEEE 488 interface, the Lab Tender with an 8 bit A/D and D/A, or the Lab Master for 12 bit A/D and D/A, a two axis Stepper Motor Controller, or the Parallel Digital-In/Digital-Out Base Board™, Video Digitization with Video VanGogh™.

**DEVELOPMENT EXPANSION** using an E+EEPROM programmer, Protozoa prototyping boards or a **TECMAR** Extender card.

**NEW PRODUCTS** are currently under development with many soon to be announced. At present shipping 26 unique IBM add-on products, we are still looking for needs to meet. If you have an need for a new product for the IBM Personal Computer, and would like to ask us about it, give a call on our Product Input Hotline at (216) 464-8317.



For IBM Personal Computer Expansion, TAKE THE NEXT STEP . . .

# Tecmar Inc.

PERSONAL COMPUTER PRODUCTS DIVISION  
23600 Mercantile Road, Cleveland, Ohio 44122  
Telephone: (216) 464-7410 Telex: 241735

Listing 1 continued:

```
470 NEXT CN
472 NEXT WC
473 N=0
474 REM SIDE 2
475 DATA 1,2,3,4,5,6,7,8,9
477 DATA 1,4,7,2,5,8,3,6,9
479 DATA 1,5,9,3,5,7
480 REM SIDE 1
482 DATA 1,10,19,4,13,22,7,16,25,1,4,7,10,13,16,19,22,25,1,13,25,7,13,19
484 REM SIDE 3
486 DATA 1,2,3,10,11,12,19,20,21,1,10,19,2,11,20,3,12,21,1,11,21,3,11,19
488 REM SIDE 4
490 DATA 7,8,9,16,17,18,25,26,27,7,16,25,8,17,26,9,18,27,7,17,27,9,17,25
492 REM SIDE 5
494 DATA 19,20,21,22,23,24,25,26,27,19,22,25,20,23,26,21,24,27,19,23,27
495 DATA 21,23,25
496 REM SIDE 6
498 DATA 3,12,21,6,15,24,9,18,27,3,6,9,12,15,18,21,24,27,3,15,27,9,15,21
499 REM MOVE CURSOR
500 FOR L1=1 TO 3
510 FOR L2=1 TO 3
515 FOR L3=1 TO 3
516 TIMER =0
517 BN=BN+1:IF BN=28 THEN BN=1
519 IF CC(BN)>1 THEN GOTO 590
520 REM TEST FOR ACTIVE SIDE
```

Listing 1 continued on page 42

# "The Perfect Marriage"

## ARBA Register and Accounting Plus\*.

Great hardware now with superb software. ARBA register, the affordable, dependable RS232 on line cash register. Accounting Plus\* Inventory Control software, comprehensive, timely, accurate. The ARBA point of sale software module that brings the two together. The ability to integrate on line real time inventory control with a total business package: G/L, Payables, Receivables, Payroll, Purchase Order, Budgeting, LY Comparisons, Electronic Spread Sheet.

# ARBA

ARBA Fine Business Computing Corporation  
890 E. Roosevelt Road  
Lombard, Illinois 60148  
(312) 620-8566

ARBA Register—\$1295.00—Suggested Retail

Dealer Pricing Available



Runs under CP/M \*\* or MP/M \*\*



\* TM Software Dimensions, Inc., Citrus Heights, Ca.  
\*\* TM Digital Research, Pacific Grove, Ca.

# SuperBrain II™



## Summa Cum Laude!

Just three years ago, Intertec stunned the microcomputer industry when its SuperBrain™ desktop computer graduated with honors . . . outperforming all the others by achieving the best price/performance ratio in its class. Today, that scholastic achievement remains unchallenged. At least until now. . .

Announcing SuperBrain II™ . . . our latest microcomputer marvel that's destined to be the "Most Likely to Succeed" in the Class of '82. With thousands of SuperBrains in use worldwide, it's no surprise that SuperBrain II users have given our new model the highest honors yet. Standard features include a powerful 64K of internal memory, a CP/M\* operating system, a 24 line × 80 column display on a 12-inch non-glare screen, a full-featured ASCII keypad with operator convenience keys, twin Z80 processors and dual RS-232 communications and printer ports. But SuperBrain II outsmarts its Class of '79 counterpart by

offering *leaner* pricing, *more* features and *better* overall system performance. New SuperBrain II features include a faster, enhanced disk operating system, a library of new visual attributes including reverse video, below-the-line descenders and impressive graphics capabilities *and* Microsoft® BASIC — all included at absolutely no extra cost!

SuperBrain II's internal circuitry has also been completely redesigned and is now computer tested to ensure optimum field reliability. Plus, there are four new SuperBrain II models from which to choose, offering disk storage capacities from 350K bytes to 10 megabytes! But, best of all, prices start as low as \$2,495, including software!

Of all the single-user microcomputers available today, our SuperBrain II is certainly in a class by itself. Not only does it outprice *and* outperform its competitive classmates, it's also backed by our comprehensive customer protection

programs — depot maintenance, extended warranties, a satisfaction guarantee and a factory sponsored users group. All in all, the SuperBrain II™ represents the most incredible microcomputer value we've ever seen (or probably ever will see) in a long, long time.

Contact your local dealer or call or write us at the address below for more information on our full line of single and multi-user microcomputers. Ask for our SuperBrain II "Buyers Guide" and find out why so many microcomputer buyers who insist on quality and value . . . insist on Intertec.

 **INTERTEC  
DATA  
SYSTEMS®**

2300 Broad River Rd. Columbia, SC 29210  
(803) 798-9100 TWX: 810-666-2115

Circle 244 on inquiry card.



### From Aspen Software

The Only Complete Document Proofreading System  
For CP/M®, TRS-80® and IBM-PC Word Processors

## PROOFREADER™

### Featuring Random House® Dictionary

- Complete Accuracy-looks up every word; does not use less accurate root word analysis, plus Random House Dictionary
- + • Full Interactive Correction-standard
- Instant Access to Dictionary
- Compact-Random House Dictionary supplied in sizes to fit your system (50,000 words standard)

## GRAMMATIK™

### Beyond Spelling Checking

- Detects typos, punctuation and capitalization errors, misused words and phrases
- Analyzes Writing Style
- Suggests Alternative Usages

## = NO ERRORS

"The programs together (Proofreader and Grammatik) offer a dynamic tool for comprehensive editing beyond spelling corrections."

-Dona Z. Meilach in Interface Age, 5, 82

"Grammatik is the perfect complement to a spelling check program."

-Dr. Alan R. Miller in Interface Age, 5:82

"If you use a word processor and a spelling checker, then you should investigate the unique capabilities of this program. Grammatik is a surprisingly fast and easy to use tool for analyzing writing style and punctuation."

-Bob Loudon in InfoWorld, 12, 81

"For the user who is as tight with his dollar as I, Proofreader is the program of choice."

-Stephen Kimmel in Creative Computing, 3:82

"Anyone involved with word processing in any way, whether writing manuals, letters, brochures, newscopy, reports, etc. is encouraged to get the excellent program Grammatik."

-A.A. Wicks in Computronics, 6:82

Grammatik and Proofreader are compatible with all CP/M, MS-DOS (incl. IBM-PC), and TRS-80 word processors. Current CP/M formats, standard 8", Northstar, Omikron, Osborne, Apple. Please call/or write for details of minimum system sizes and availability of additional disk and operating system formats. Shipping costs included. Please specify your system configuration when ordering. Dealers inquiries invited.

	Proofreader	Grammatik	Both
CP/M, MS-DOS	\$129.00	\$150.00	\$250.00
TRS-80 Model II	n/a	\$99.00	
TRS-80 Mod. V/III	\$89.00	\$59.00	\$139.00

Random House is a registered trademark of Random House, Inc. Other registered trademarks: CP/M: Digital Research; TRS-80: Tandy Corp.; MS-DOS: Microsoft; IBM: IBM; Proofreader, Grammatik: Aspen Software Co.

## Aspen Software Co.

P.O. Box 339-B Tijeras, NM 87059  
(505) 281-1634



Listing 1 continued:

```

523 IF L3=1 THEN GOSUB 1100
525 IF L1 = 1 THEN GOSUB 1200
530 IF L2=1 THEN GOSUB 1300
540 IF L2=3 THEN GOSUB 1400
545 IF L1=3 THEN GOSUB 1500
550 IF L3=3 THEN GOSUB 1600
555 IF BN=14 THEN 590
559 REM DELAY LOOP
560 IF TIMER < 60 THEN 560
561 K$=INKEY$
562 IF K$ <> "" THEN 800
569 REM CLEAR SUBCUBE COLOR
570 FOR M=1 TO N
575 PAINT(SH(M),SV(M)),P,F
580 NEXT M
585 N=0
590 NEXT L3
591 NEXT L2
592 NEXT L1
599 GOTO 500
800 REM RECORD MOVE
803 PLAY "L25;A;D;A;D;"
805 CC(BN)=PN
809 REM FIND BN IN TABLE
810 FOR WC=1 TO 48
812 FOR CN=1 TO 3
814 IF WN(WC,CN)=BN THEN GOSUB 840
818 NEXT CN
820 NEXT WC
830 K$=""
835 IF PN=PA THEN PN=PB ELSE PN=PA
838 N=0
839 GOTO 590
840 HT=0
841 REM FIND 3 TOGETHER
842 FOR LT=1 TO 3
844 TM=WN(WC,LT)
846 IF CC(TM)=PN THEN HT=HT+1
847 NEXT LT
848 IF HT=3 THEN GOSUB 850
849 RETURN
850 IF PN=PB THEN 870
851 REM RECORD WIN PLAYER A
852 COLOR PA,F
854 LINE(192,AS)-(208,AS-4),PRESET,B
855 PAINT(200,AS-2),PA,F
860 AS=AS-4
865 PLAY"02;L2;A"
869 RETURN
870 COLOR PB,F
873 REM RECORD WIN PLAYER B
875 LINE (220,BS)-(236,BS-4),PRESET,B
877 PAINT(224,BS-2),PB,F
880 BS=BS-4
885 PLAY"04;L2;C"
890 RETURN
899 REM PAINT SUBCUBE
900 HP=SH-LM*(L1-1)+RM*(L3-1)
910 HV=SV-LU*(L1-1)-RU*(L3-1)+DM*(L2-1)

```

Listing 1 continued on page 44

# CompuStar™



## The Best Made Better

When we unveiled our CompuStar™ multi-user terminal system just over a year ago, we thought we had created the most powerful, lowest-priced multi-user computer we would ever manufacture. We were wrong. Today, we've made our best even better!

Our newly redesigned CompuStar™ boasts the same performance statistics that made its predecessor such an overnight success, plus a host of exciting *new* features. CompuStar users now get the added benefits of dual character set capability, an expanded library of visual attributes including reverse video, underlining and below-the-line descenders, an enhanced disk operating system and Microsoft® BASIC — all at no extra cost! And single-user systems now start at as little as \$2995.

There are four types of CompuStar™ workstations (called Video Processing Units or VPU's) that can be connected into a variety of central disk systems with 10 to 96 megabytes of multi-user storage.

Up to 255 VPU's can be tied together to form a massive multi-user network. Or, you can start with only a single VPU and easily expand your system as your processing needs become more sophisticated. But whether you start with one or one-hundred VPU's, you'll probably never outgrow your CompuStar. Unlike other systems, you configure the CompuStar the way *you* want it . . . connecting any combination of VPU's in a "daisy chain" fashion into the central disk system. And since each VPU has its own twin Z80 processors, its own CP/M\* operating system and a full 64K of internal memory, (not to mention disk capacities of up to 1½ million bytes), overall system response time remains unbelievably fast! And that's a claim most of the other multi-user vendors just can't make.

Inside our new CompuStar you'll find a level of design sophistication that's destined to establish a new standard for the industry. A series of easy-to-service modular components has been

engineered to yield the most impressive reliability figures we've ever seen. But CompuStar users are not only thrilled with our system's performance (and the miserly few dollars they spent to get it), they also have the peace of mind of knowing that Intertec's comprehensive customer protection and field service programs will insure their total after-the-sale satisfaction.

For more information on what just may be the last multi-user microcomputer you'll ever (have to) buy, ask your dealer today about our all new CompuStar™ system. Or, contact us at the number and address below. We'll gladly explain how we've made our best . . . even better!

 **INTERTEC  
DATA  
SYSTEMS®**

2300 Broad River Rd. Columbia, SC 29210  
(803) 798-9100 TWX: 810-666-2115

Circle 245 on inquiry card.

Listing 1 continued:

```
920 PAINT(HP,HV),PN,F
930 N=N+1
940 SH(N)=HP
950 SV(N)=HV
990 RETURN
1000 REM SET VARIABLES EACH SIDE
1100 BW=2*FX/3
1110 SH=FH-.5*BW
1120 LM=BW:RM=0:RU=0:DM=BW
1130 SV=FV+.5*BW
1140 LU=.5*BW
1150 GOSUB 900
1190 RETURN
1200 BW=2*FX/3
1210 SH=FH+.5*BW
1220 LM=0:RM=BW:LU=0:DM=BW
1230 RU=.5*BW
1240 SV=FV+.5*BW
1280 GOSUB 900
1290 RETURN
1300 BW=2*FX/3:SH=FH
1310 LM=BW:RM=BW
1320 SV=FV-.5*BW
1330 LU=.5*BW:RU=.5*BW:DM=0
1380 GOSUB 900
1390 RETURN
1400 BW=2*BX/3
1410 SH=BH:LM=BW:RM=BW
1420 SV=BV+2.5*BW
1430 LU=.5*BW:RU=.5*BW:DM=0
1480 GOSUB 900
1490 RETURN
1500 BW=2*BX/3
1510 SH=BH-2.5*BW
1520 LM=0:RM=BW
1530 SV=BV-1.5*BW
1540 LU=0:RU=.5*BW:DM=BW
1580 GOSUB 900
1590 RETURN
1600 BW=2*BX/3
1610 SH=BH+2.5*BW
1620 LM=BW:RM=0
1630 SV=BV-1.5*BW
1640 LU=.5*BW:RU=0:DM=BW
1680 GOSUB 900
1690 RETURN
```

## IBM's New Companion Frontier Technologies Corporation

The Systems Company bringing Technology Frontiers closer to you.  
Providing full **3-Year Warranty** and total system support.

### HARDWARE SUPPORT

- Memory Boards  
64K, 128K, 192K, 256K  
RS-232C Option  
Parallel Port Option
- IEEE-488 Controller  
Real Time Clock Option  
Serial Channel Option (RS-232C)
- Advanced Communication Bds.  
Single Channel or Dual Channel  
Sync or Async Operation  
HDLC, SDLC, X-25 Protocols  
Real Time Clock Option  
Parallel Port Option
- Prototype Board

### HARDWARE FEATURES

Full 3-Year Warranty  
Total IBM BUS Compatibility  
Easy Installation  
Thorough Documentation

### SOFTWARE SUPPORT

- IEEE-488 Bus Manager  
Higher level user friendly interface to the bus devices
- Communications Package (COMPAC)  
Menu Driven Mode Selection  
Easy Commands to Communicate with the Host
- Entrepreneur™  
Ideal Software for small business organizations

### SOFTWARE FEATURES

Free upgrade releases for 1 year. Menu driven, user friendly packages. IBM PC DOS compatible operation

### FUTURE PRODUCTS

Data Base Manager • Winchester Disk Subsystem • Medical Office System • Ethernet Controller

Call for unbeatable prices.  
Major credit cards accepted

(414) 964-8689  
P.O. Box 11238  
Milwaukee, WI 53211

Frontier  
Technologies  
Corporation



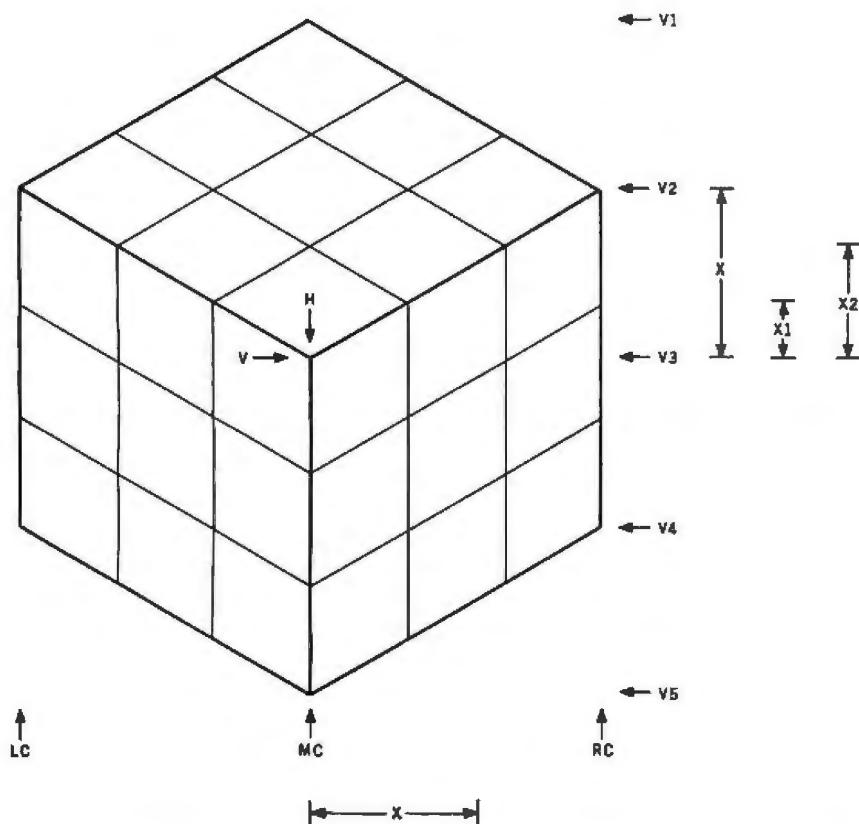

Figure 3: Location of the variables used to draw the initial view of the cube.

Variable	Description
X	one-half the difference between the center of the cube and the outer limits of the cube in a horizontal or vertical direction
H	the horizontal coordinate of the cube center
V	the vertical coordinate of the cube center
LC	the leftmost corner of the cube
MC	the middle corner of the cube
RC	the rightmost corner of the cube
V1	the top of the cube
V2	$V1 - X$
V3	$V1 - 2X$
V4	$V1 - 3X$
V5	the bottom of the cube

Table 1: Description of the variables used to draw the cube.

Text continued from page 36:

lines required for the cube. The Paint command is used to color the sub-cubes.

The subroutine that draws the cube is written so that the back view of the cube is drawn in the mirror image of the front cube, putting the face that is closest to the viewer on the bottom of the cube instead of the top. This is achieved by making *BX* a negative number in line 407, which reverses all drawing directions.

The preceding change in the program illustrates the symmetry in-

involved in drawing a geometric figure with a computer. When I finished the program, I felt that drawing each line using a command was a crude way to program this figure. I suspect a better programmer would be able to reduce the number of statements considerably by using `FOR...NEXT` loops.

### Moving the Cursor

When I started writing the program, I thought that moving the cursor among the subcubes would be simple, but it turned out to be the hardest task. The scheme I finally

# INTELLIGENT PRINTER INTERFACE

Free Your Computer from the  
Mundane Task of Printing



Imagine being able to use your computer seconds after beginning an extensive printout.

Visualize your printout with page breaks, page numbering and titles, margins of your choice, indented carryover lines, on any size paper!

Appreciate the time and money you will save by not waiting for your printer.

SooperSpooler, a buffered printer interface, maintains control over your printer while you go on using your computer for more productive activities. Eliminate waiting while your printer pecks through a long document. SooperSpooler accepts information from your computer at up to 3000 characters per second and feeds it to your printer as fast as it can handle it—without using any of your computer's memory or time!

### SooperSpooler features include:

- 16K Memory (62K optional)
- Buffer Status Readout
- Space Compression
- Pagination
- Single Sheets
- Headers and Page Numbering
- Indentation on Carryover Lines
- Self Test Routine
- Features also Software Controllable
- Plugs into Most Computer Systems
- ★ 16K Parallel I/O Unit—\$349.00!
- ★ Serial I/O Option—\$95.00
- ★ 46K Memory Option—\$159.00

**SooperSpooler™ by Compulink—**  
The missing link that gives your microcomputer mainframe printing.

## COMPULINK CORPORATION

1840 Industrial Circle  
Longmont, CO 80501 (303) 651-2014

Send for brochure  
Dealer inquiries welcome  
Call for information: 800-525-6705

# EXPOTEK

2723 W. Windrose • Suite 3  
Phoenix, Arizona 85029  
1-800-528-8960

## GUARANTEED LOW PRICES

### APPLE CARDS

16K RAM — \$99    Z80 CARD — \$279  
Videx Card — \$249    Smart Term — \$179  
32K Atari Card — \$99.50    Clock CARD — \$220

### ALTOS

5-15D — \$2290    5-5D — \$4399

### ANADEX

9500A — \$1290    9501A — \$1290

### ATARI

400-16K — \$289    800-18K — \$659  
410 — \$79    810 — \$435  
825 — \$589    850 — \$149

### CITOM

F-10P — \$1380    F-10S — \$1525

### Prowriter

8510AP — \$489    8510ACD — \$610

### DATASOUTH

DS120 — \$595    DS180 — \$1259

### DIABLO

830RO — \$1945    620 — \$1295

### EPSON

MX80FT — \$515    MX80 — \$439  
MX100 — \$699    Graphic Rom — \$45

### HAZELTINE

1500 — \$995    ESPRIT — \$515

### MICRO SCI A2

\$350 — Apple Drive/Card — \$400

### MODEMS

HAYS — MICROMODEM — \$290  
HAYS — SMARTMODEM — \$229  
Penril — 300/1200 (212A) — \$695

### MONITORS

BMC Green — \$95    Color RGB — \$550  
Amdek 3000 — \$159    Color — \$380  
Sanyo-Green — \$225    Color — \$335

### NORTHSTAR

Advantage — \$2795    Horizon 640D — \$2795.

### NEC

8023 — \$489    7710 — \$2350

### MPI

88G — \$550    99G — \$650

### SOROC

120 — \$659    135 — \$689

### TELEVIDEO

910 — \$569    925 — \$730  
920 — \$735    950 — \$915

### TI

810 — \$1240    820 — \$1785

### ZENITH

Z19 — \$699    Z89 — \$2129

### OKIDATA

M80 — \$320    M83A — \$699  
M82A — \$425  
M84P — \$1059    M84S — \$1225

### SOFTWARE

All Major Brands — \$CALL

### DISKETTES/BOXES

Elephant — \$20    Scotch — \$25    Dysan — \$35

All Prices Subject To Change

**Customer Service**  
**602-863-0759**

Subcube Number N	Vertical Slice L1	Horizontal Row L2	Vertical Column L3
1	1	1	1
2	1	1	2
3	1	1	3
4	1	2	1
5	1	2	2
6	1	2	3
7	1	3	1
8	1	3	2
9	1	3	3
10	2	1	1
11	2	1	2
12	2	1	3
13	2	2	1
14	2	2	2
15	2	2	3
16	2	3	1
17	2	3	2
18	2	3	3
19	3	1	1
20	3	1	2
21	3	1	3
22	3	2	1
23	3	2	2
24	3	2	3
25	3	3	1
26	3	3	2
27	3	3	3

Table 2: Values of variables L1, L2, and L3 used to determine the position of the cursor.

settled on was to move the cursor using three FOR...NEXT loops at lines 500-599. The outer loop (L1) represents one of three vertical slices of the cube, the next loop (L2 in line 510) represents the horizontal rows on each slice, and the inner loop (L3 in line 515) represents the vertical columns on each slice. Table 2 shows the contents of the three variables that are used to control the loops for each subcube, and figure 1 shows the subcube numbers.

An inspection of table 2 and figure 1 reveals that the position of the cursor on a side can be determined by the value of one of the variables L1 to L3. For example, whenever one of the top subcubes (side 3) is addressed, L2 is a 1. Line 530 tests L2 for a 1 and executes the subroutine that paints the top side of the cube.

The subroutines at lines 1100, 1200, 1300, 1400, 1500, and 1600 that handle moving the cursor on each side use another subroutine at line 900 to paint the player's color. Before it executes a GOSUB 900, the calling subroutine first determines the con-

tents of the variables that will be used by line 900 to determine the location of the subcube to paint. The variable HP contains the horizontal position, and variable HV contains the vertical position that the Paint command uses. The amount of movement is determined by the distance each subcube is from subcube 1 when L1, L2, or L3 is 1.

For example, when the cursor is on subcube 1 then L1, L2, and L3 are all 1, and subroutines at lines 1100, 1200, and 1300 will be executed to paint subcube 1 on three sides. When the subcube changes to 2, L3 becomes 2, while L2 and L1 stay at 1, and subroutines at lines 1200 and 1300 are executed. These two subroutines store values in variables RM and RV that equal the number of dots needed to move to subcube 2 from subcube 1. When the statements at lines 900 and 910 are executed, variables HP and HV are adjusted by the values in variables RM and RV, and subcube 2 is painted. This procedure is used for each subcube. If you work out the values in the subroutines using table



# WHEN WE ANNOUNCED SAGE II, 8-BIT COMPUTERS BIT THE DUST.



## **16-BIT, 8 MHZ, 68000 MICROPROCESSOR.**

The new Sage II doesn't look exactly awesome. Some folks even mistake it for a disk subsystem.

But the fact is, 8-bit microcomputers don't stand a chance against it. Minicomputers are shaking in their boots. And even a few mainframes are running scared.

Because the Sage II is based on the incredible 68000.

## **UP TO 512K, NOT COUNTING DRIVES.**

With its 24-bit address bus, the Sage II can address 16 megabytes.

The stripped down version features a mere 128K RAM.

On top of that, you can add another 384K of "RAM DISK" (on-board RAM that looks like a super-fast disk to the operating system).

Then come the real disk drives. Your choice of 40 or 80 track, 320K to 1.3 megabyte, 5-1/4". A 10K program loads in half a second.

## **p-SYSTEM\* OPERATING SYSTEM.**

This optional, interactive operating system makes it possible to use programs currently running on 8-bit computers.

It supports Pascal, FORTRAN 77, BASIC and 68000 Macro Assembler languages and a host of utility and applications programs.

## **MORE FOR THE MONEY.**

Prices for the Sage II start at just \$3,600 with one disk drive and 128K RAM.

No other computer in history has offered so much performance per unit price.

Call or write us today for the whole story.

195 North Edison Way, Suite 14  
Reno, Nevada 89502  
(702) 322-6868

\* UCSD p-System is a trademark of the Regents of the University of California.

**SAGE**  
COMPUTER TECHNOLOGY

Circle 412 on Inquiry card.

Variable Name	Side and Subroutine Line Numbers					
	Side 1 1100	Side 2 1200	Side 3 1300	Side 4 1400	Side 5 1500	Side 6 1600
BW	2•FX/3	2•FX/3	2•FX/3	2•BX/3	2•BX/3	2•BX/3
SH	FH - .5•BW	FH + .5•BW	FH	BH	BH - 2.5•BW	BH + 2.5•BW
LM	BW	0	BW	BW	0	BW
RM	0	BW	BW	BW	BW	0
SV	FB + .5•BW	FV + 5•BW	FV - .5•BW	BV + 2.5•BW	BV - 1.5•BW	BV - 1.5•BW
LU	.5•BW	0	.5•BW	.5•BW	0	.5•BW
RU	0	.5•BW	.5•BW	.5•BW	.5•BW	0
DM	BW	BW	0	0	BW	BW

Table 3: Formulas used to compute the distance to move the cursor to a particular subcube from subcube 1.

3, you will see that the table does give the location of the subcube on each side. It also shows the formulas used to compute these values for each side.

### Keeping Score

A player scores a point when he gets three subcubes together in his color in a horizontal, vertical, or diagonal direction. Each subcube can have as many as three faces; therefore, it is possible for a subcube to be involved in as many as nine winning combinations. In fact, you can score as many as 9 points on three different faces in one move. Photo 2 shows the game after one player has scored 6 points by marking subcube 1.

The program keeps score first by

building an array in memory for all the possible winning combinations using lines 450-499. There are 6 sides with 8 winning combinations on a side, or a total of 48 winning combinations. The winning numbers are read from memory in groups of 3 and stored in array WN, which is dimensioned in line 54.

Each time a player makes a move, the subroutine in line 800 is executed. Array CC keeps track of the player who has colored each subcube. Array WN is then searched to see if the subcube that was just colored is in a winning combination. If the subcube number is found, the three subcubes are checked to see if they are all the same color. If they are, then the

player is given credit for a score in the subroutine in line 850. The entire table of winning combinations is searched in this way, and all winning combinations are identified and displayed. Photo 3 shows the game after all subcubes have been colored.

### Future Changes

This program was written so that it could be easily changed. The colors, location of the cubes, and sizes of the cubes can all be changed by changing variables in the beginning of the program. The cursor can be made to move faster or slower by changing the constant in line 560.

This version is a straightforward game without much variety. I am

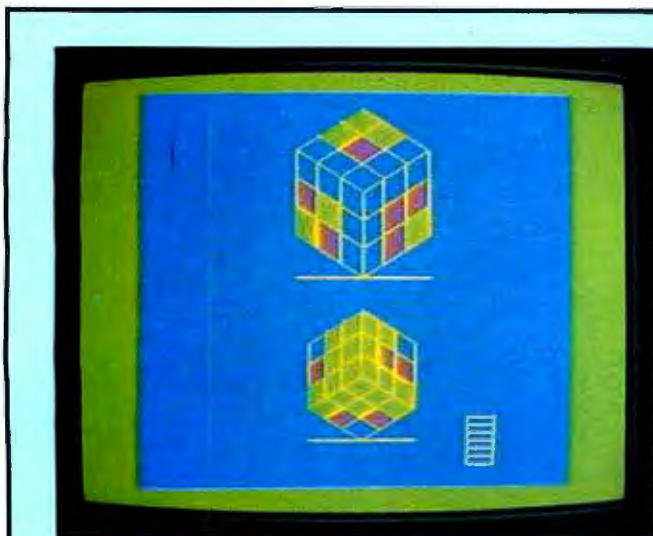

Photo 2: One player has scored 6 points by coloring the seven subcubes on the forward-facing cube.

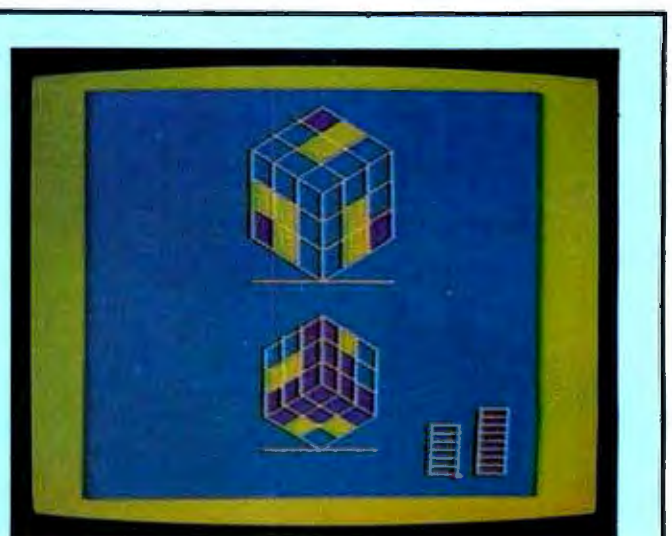
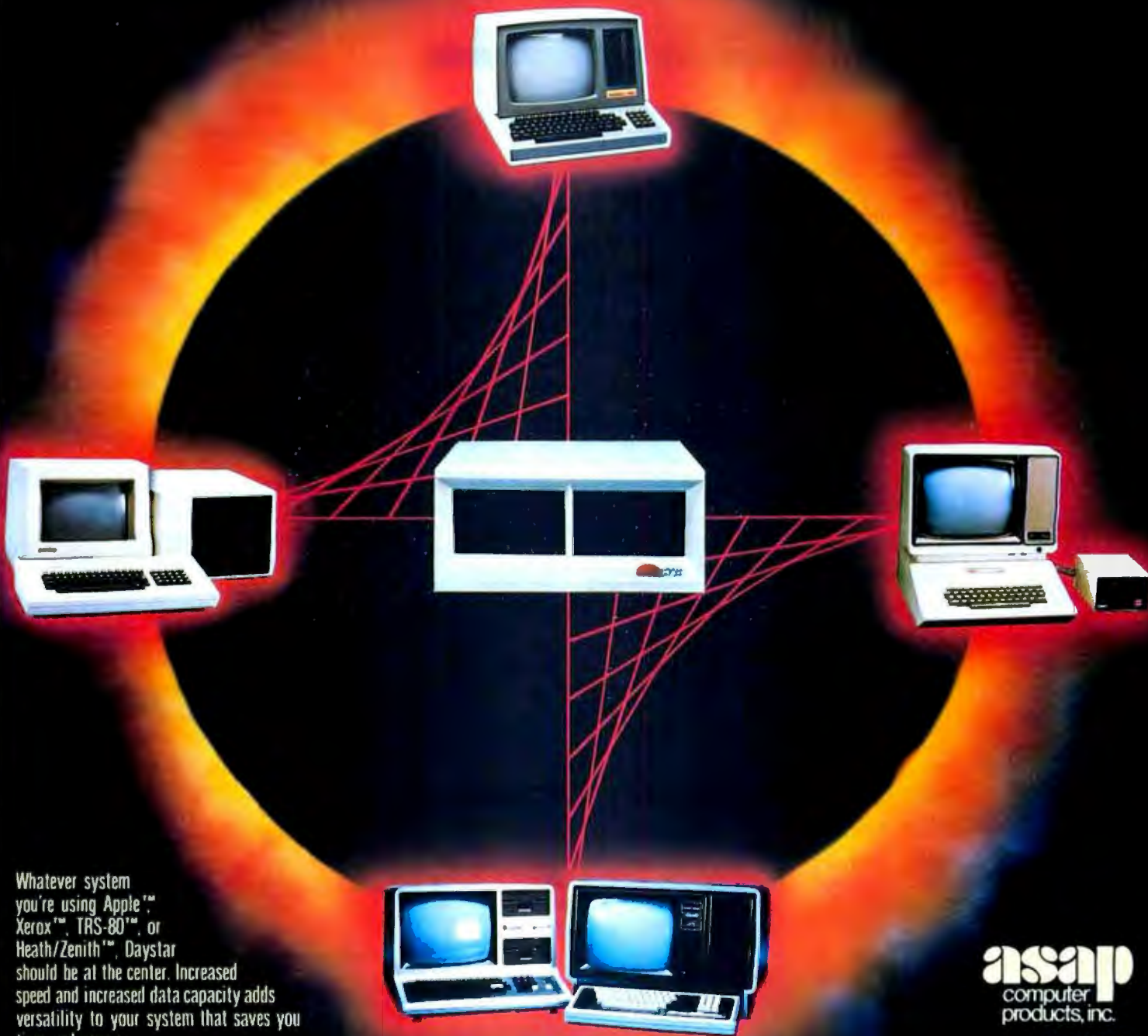

Photo 3: Screen display showing all the subcubes colored. The scores for each player are shown in the lower-right corner.

# DAYSTAR at the center of your SYSTEM



Whatever system you're using Apple™, Xerox™, TRS-80™, or Heath/Zenith™, Daystar should be at the center. Increased speed and increased data capacity adds versatility to your system that saves you time and money.

Through the use of an intelligent controller using I/O Ports and on-board data buffer feature, your microcomputer can perform up to 9 times faster.

Daystar increases the data capacity of your system, with 6.4 megs or 12.8 megs of unformatted storage and each controller will handle up to 4 drives. A 1 megabyte floppy back-up is also available. This increased capacity allows your system to expand as your needs change.

Daystar, the perfect center for your system, at an affordable price.

This subsystem is available with interfaces for:

Xerox®, NEC 8000®, Apple II®, Commodore®, VIC 20®, TRS-80 Model II®, Heath/Zenith 89™, S-100, and soon Apple III®, TRS-80 III®.

**asap**  
computer  
products, inc.

1198 E. Willow St.  
Signal Hill, CA 90806  
(800) 421-7701 • (213) 595-6431 • (714) 891-2663

**ASAP COMPUTER PRODUCTS LTD.**  
116 Viceroy Road, D-12 Concord, Ontario  
L4K1A9 Canada (416) 738-0500 (800) 268-1996

**DAYSTAR**  
TECHNOLOGY INC.

# A BETTER DEAL THAN MAIL ORDER!

## YOU SAVE WHEN WE BUY FOR YOU AS YOUR AGENT.

We are a commercial buying company. Our fee is one-fourth of what we save you off list price.

We offer:

- Better prices
- Exporting
- Leasing
- Full service and support
- Access to 500 manufacturers
- Assembly, integration, testing

These are just a few of the products we can buy for you:

### COMPUTERS

Adds Multivision I	\$ 3,074	IBM Personal comp.	CALL
Alpha Micro 1030	12,047	Baby Blue	CALL
Alpha Micro 1051	17,634	Davong 5 meg. H. D.	1,575
<b>Alspa AC1-2/SS</b>	<b>2,320</b>	Seattle boards	CALL
<b>Altos 8000-10</b>	<b>6,295</b>	IBC Cadet	4,211
Altos 8000-15	3,585	Micromation	CALL
Altos 8600-10	7,586	NEC 8000 64K PC system	
<b>Altos Series 5-15D</b>	<b>2,182</b>	incl. CP/M, Wordstar	2,266
Altos Series 5-5D	4,372	<b>NorthStar Advantage</b>	<b>2,634</b>
Apple 2 + 48K	1,208	NorthStar Adv. H.D. 5	4,395
BMC 20 B	5,422	NorthStar Hor 64K QD	2,650
CCS Series 300-1A	4,414	Onyx 5001 MU-6	7,350
Columbia Data	CALL	Onyx 8000 MU-10	7,900
Compupro/Godbout	26% OFF	Sanyo 2000	2,708
Corvus Concept	CALL	Seattle System 2	3,251
Cromemco System 1	2,946	<b>Televideo TS-802</b>	<b>2,600</b>
Cromemco System 2	3,400	Televideo TS-802H	4,950
Cromemco 68000 System 1	4,395	Televideo TS-806	5,200
<b>DEC VT-180xx</b>	<b>3,344</b>	Vector 2600	3,895
Dual	12,636	Vector 3005	5,495
Dynabyte	26% OFF	Vector 4	CALL
Eagle II	2,350	<b>Victor</b>	<b>22% OFF</b>

### PRINTERS

<b>Brother, parallel, daisy</b>	<b>853</b>	NEC 3510	CALL
C. Itoh F-10, daisy	1,400	NEC 7710 R/O	2,325
C. Itoh Comet II, dot	799	NEC 7720 KSR	2,685
Diablo 620, daisy, 25 cps	1,260	NEC/Sellum 1, 16K, tractor	2,595
Diablo 630, daisy	2,098	<b>Qume 9/45 full panel</b>	<b>2,045</b>
IDS Prism 80	740	Qume 9/55 full panel	2,180
<b>IDS Prism 132 column</b>	<b>1,430</b>	Smith Corona TP-1, daisy	681
		Tally	CALL
		<b>Texas Instr. TI 810</b>	<b>1,285</b>

### DISK DRIVES, MODEMS, ETC.

Amdek Color II term.	694	Houston Instr. DMP-2	841
Ventel 212 + modem	765	<b>Houston Instr. DMP-4</b>	<b>1,195</b>
<b>Corvus 10 meg. H.D.</b>	<b>3,825</b>	Houston Instr. DMP-7	1,693
DEC VT-100 terminal	1,390	Morrow 20 meg. H.D.	3,650

Mastercard, VISA at 3% handling fee. Prices subject to change without notice. Minimum fee \$150. 15% restocking charge.

**EXPORT SERVICES available.** We are buying agents for overseas computer dealers and distributors. International Telex 470851

## THE PURCHASING AGENT

1635 School Street, Suite 101, Moraga, CA 94556

Call Toll Free 800-227-2288 In California (415) 376-9020

working on another version now that will make the game more competitive. This can be done by moving two cursors at once, random movements, changing speeds, etc. You should be able to design your own game version with some thought.

### Some Reflections

My reasons for doing this project initially were to learn the Color Computer's graphics capabilities, win the BYTE game contest, and do something with my idle computer. Somewhere along the way I thought it might be educational to other people and so decided to write this article.

I did learn a lot about the Color Computer graphics, and what I learned reinforced my opinion that the Color Computer is a powerful computer for the money. In many ways the graphics are as powerful as those for the IBM Personal Computer, which costs considerably more. Some of the graphics commands are limited, but you can usually find a way to accomplish your objectives. Doing graphics in BASIC will probably be too slow for many projects requiring fast movement of objects on the screen, and these projects will have to be done with assembly-language programs or machine-language subroutines.

All in all, I am glad I engaged in this effort. I hope that you can learn something from my efforts that will save you some time on a computer project, or perhaps you will simply enjoy playing Three Dee Tee. If so, the effort will have been worthwhile. ■

### Improved Version Available

The author will make copies of an improved version of his program available to BYTE readers. Send a blank cassette tape, a self-addressed stamped envelope, and a check or money order for \$8 to:

John Stuart  
6345 South 70th East Ave.  
Tulsa, OK 74133



**In an age when new standards are constantly emerging,  
one disk consistently meets or exceeds them all.**

## **Maxell. The Gold Standard.**

Not all disks are created equal. Some are better than others. To find out what's best for you, look for Maxell disks. They now carry the Gold Standard symbol of quality. It's your assurance Maxell disks meet or exceed every definition of quality. No matter who establishes it. We've earned this universal superiority by never relaxing our uniquely demanding quality control. Every aspect of manufacturing is checked, then checked again.

Your benefits are many. Take the perpetual problem of drop-outs. A drop-out is a tiny defect that wastes time and degrades computer accuracy and performance. Now that you understand what a drop-out is, forget it. Maxell disks don't have any. Each disk comes to you certified

drop-out free at the time of manufacture. You can depend on this quality protecting your valuable programs and programming time, indefinitely. We've run disks over ten million passes under conditions designed to find weak points and wear. We couldn't. And you won't.

There is a Maxell disk for the floppy system you use, or plan to use. Check your computer's instructions. Or write for our complete, highly informative brochure.

When you set the Gold Standard as your level of quality, you'll benefit from improved disk performance, immediately. Bank on it.



**maxell®**

# Our yellow pages make the competition go green.

There's no recession at Alpha Byte. Our business is booming.

In the past year alone, our sales have increased ten-fold. And they're still on the rise.

We believe it's because we offer a unique combination of low prices and outstanding service — a package of knowledgeable salespeople, quick and efficient shipping, convenient payment options and a guarantee of satisfaction — at below-competitive prices!

Our satisfied customers are spreading the word.

We built a reputation, and a booming business, on our prices and your satisfaction. It's no wonder the competition is envious.

## 16K RAM KITS . . . 13.95

Set of 8 NEC 4116 200 ns. Guaranteed one full year.

## DISKETTES

**ALPHA DISKS . . . 21.95**  
Single sided, certified Double Density 40 Tracks, with Hub-ring. Box of 10 Guaranteed one full year

## VERBATIM DATALIFE

MD 525-01, 10, 16 . . . 26.50  
MD 550-01, 10, 16 . . . 44.50  
MD 557-01, 10, 16 . . . 45.60  
MD 577-01, 10, 16 . . . 34.80

FD 32 or 34-9000 . . . 36.00  
FD 32 or 34-8000 . . . 45.60  
FD 34-4001 . . . 48.60

## DISKETTE STORAGE

5 1/4" PLASTIC LIBRARY CASE . . . 2.50  
8" PLASTIC LIBRARY CASE . . . 3.50  
PLASTIC STORAGE BINDER w/ Inserts . . . 9.95  
PROTECTOR 5 1/4" (50 Disk Capacity) . . . 21.95  
PROTECTOR 8" (50 Disk Capacity) . . . 24.95  
DISK BANK 5 1/4" . . . 5.95  
DISK BANK 8" . . . 6.95

## NEC PERSONAL COMPUTERS

PC-8001A CPU . . . 899.00  
PC-8012A I/O . . . 559.00  
PC-8033A DISK I/O . . . 125.00  
PC-8031A DUAL DISK . . . 899.00

## ALTOS COMPUTER SYSTEMS

Call Alpha Byte for our low Altos prices.

## ATARI COMPUTERS

ATARI 800 . . . 679.00  
ATARI 400 (16K) . . . \$CALL  
ATARI 810 DISK DRIVE . . . 445.00  
ATARI 850 INTERFACE . . . 169.00  
ATARI 410 PROGRAM RECORDER . . . 75.00  
EPSON CABLE . . . 35.00  
MEMORY MODULE (16K) . . . 89.95  
JOYSTICK CONTROLLER . . . 10.00  
PADDLE CONTROLLERS . . . 19.95  
STAR RAIDERS . . . 35.00  
MISSILE COMMAND . . . 35.00  
ASTEROIDS . . . 35.00  
PACMAN . . . 35.00

## INTEC PERIPHERALS RAM MODULES

48K FOR ATARI 400 . . . 279.00  
32K FOR ATARI 800 . . . 125.00

## ACTIVISION ATARI CARTRIDGES

LAZAR BLAST . . . 21.95  
SKIING . . . 21.95  
DRAGSTER . . . 21.95  
BOXING . . . 21.95  
CHECKERS . . . 21.95  
BRIDGE . . . 21.95  
KABOOM . . . 21.95

## HEWLETT PACKARD

**HP CALCULATORS**  
HP-11C LCD SCIENTIFIC . . . 115.95

HP-12C LCD BUSINESS . . . 128.95  
HP-37E BUSINESS . . . 64.95  
HP-32E SCIENTIFIC w/ STATS . . . 46.95  
HP-33C Programmable Scientific . . . 76.95  
HP-41C Advanced Programmable . . . 211.95  
HP-41CV Advanced Prog 2K mem . . . 274.95

## HP-41 PERIPHERALS

HP-82108A MEMORY MODULE . . . 27.95  
HP-82170A Quad Memory Module . . . 89.00  
HP-82143A PRINTER/PLOTTER . . . 324.95  
HP-82160A IL INTERFACE . . . 119.00  
HP-82161A DIGITAL CASSETTE . . . 419.00  
HP MATH PAC . . . 29.00  
HP STATISTICS PAC . . . 29.00  
HP REAL ESTATE PAC . . . 39.00  
HP SURVEYING PAC . . . 29.00  
HP STRUCTURAL ANALYSIS PAC . . . 39.00

## HP COMPUTERS

HP-85A PERSONAL COMPUTER . . . 2195.00  
HP SINGLE 5 1/4" DISK DRIVE . . . 1295.00  
HP DUAL DISK DRIVE . . . 1995.00  
HP-85A 16K MEMORY MODULE . . . 239.00  
HP-7225B GRAPHICS PLOTTER . . . 2195.00  
HP PLOTTER MODULE . . . 605.00  
HP HP-IB INTERFACE . . . 329.00  
HP STD APPLICATIONS PAC . . . 83.00  
HP GENERAL STATISTICS PAC . . . 83.00  
HP GRAPHIC PRESENTATIONS . . . 159.00  
HP VISICALC PLUS . . . 159.00  
HP ROM DRAWER . . . 39.00  
HP PRINTER/PLOTTER ROM . . . 116.00  
HP MASS STORAGE ROM . . . 116.00  
HP RS-232 INTERFACE . . . 329.00

## PRINTERS

ANADEX DP 9500 . . . 1295.00  
ANADEX DP 9501 . . . 1295.00  
C-ITOH F-10 40 CPS PARALLEL . . . 1545.00  
C-ITOH 45 CPS PARALLEL . . . 1770.00  
C-ITOH 40 CPS SERIAL . . . 1295.00  
C-ITOH PROWRITER PARALLEL . . . 549.00  
C-ITOH PROWRITER SERIAL . . . 695.00  
EPSON MX-80 W/GRAFTRAX PLUS . . . \$CALL  
EPSON MX-80 F/T W/GRAFTRAX PLUS . . . \$CALL  
EPSON MX-100 W/GRAFTRAX PLUS . . . \$CALL  
EPSON GRAFTRAX PLUS . . . 60.00  
IDS PRISM 80 W/O COLOR . . . 1099.00  
IDS PRISM 80 W/COLOR . . . 1599.00  
IDS PRISM 132 W/COLOR . . . 1799.00  
NEC 8023A . . . 485.00  
NEC SPINWRITER 3530 P. RO . . . 1995.00  
NEC SPINWRITER 7710 S. RO . . . 2545.00  
NEC SPINWRITER 7730 P. RO . . . 2545.00  
NEC SPINWRITER 7700 D SELLUM . . . 2785.00  
NEC SPINWRITER 3500 SELLUM . . . 2285.00  
OKIDATA MICROLINE 80 . . . 389.00  
OKIDATA MICROLINE 82A . . . 469.00  
OKIDATA MICROLINE 83A . . . 720.00  
OKIDATA MICROLINE 84 . . . 1199.00

OKIGRAPH 82 . . . 33.95  
OKIGRAPH 83 . . . 33.95

## APPLE HARDWARE

VERSA WRITER DIGITIZER . . . 259.00  
ABT APPLE KEYPAD . . . 119.00  
SOFTCARD PREMIUM SYSTEM . . . 825.00  
MICROSOFT Z-80 SOFTCARD . . . 299.00  
MICROSOFT RAMCARD . . . 159.00  
VIDEX 80 x 24 VIDEO CARD . . . 299.00  
VIDEX KEYBOARD ENHANCER II . . . 129.00  
VIDEX ENHANCER REV 0-6 . . . 99.00  
M & R SUPERTERM 80 x 24 VIDEO BD . . . 315.00  
SSM AIO BOARD (INTERFACE) A & T . . . 165.00  
SSM AIO BOARD (INTERFACE) KIT . . . 135.00  
APPLE COOLING FAN . . . 44.95  
T/G JOYSTICK . . . 44.95  
T/G PADDLE . . . 29.95  
T/G SELECT-A-PORT . . . 54.95  
VERSA E-Z PORT . . . 21.95  
MICRO SCI A2 W/CONTROLLER . . . 510.00  
MICRO SCI A2 W/O CONTROLLER . . . 419.00  
MICRO SCI A40 W/CONTROLLER . . . 479.00  
MICRO SCI A40 W/O CONTROLLER . . . 409.00  
MICRO SCI A70 W/CONTROLLER . . . 829.00  
MICRO SCI A70 W/O CONTROLLER . . . 549.00  
THE MILL-PASCAL SPEED UP . . . 270.00  
PROMETHEUS VERSACARD . . . 180.00  
LAZAR LOWER CASE + . . . 59.00  
MICROBUFFER II 16K W/GRAPHICS . . . 259.00  
MICROBUFFER II 32K W/GRAPHICS . . . 299.00

## MONITORS

NEC 12" GREEN MONITOR . . . 179.00  
NEC 12" COLOR MONITOR . . . 399.00  
SANYO 12" MONITOR (B & W) . . . 249.00  
SANYO 12" MONITOR (GREEN) . . . 269.00  
SANYO 13" COLOR MONITOR . . . 469.00  
ZENITH 12" HI RES GREEN MONITOR . . . 124.00  
AMDEK COLOR I . . . 389.00  
AMDEK RGB COLOR II . . . 859.00  
AMDEK RGB INTERFACE . . . 169.00  
COMREX 12" GREEN MONITOR . . . 165.00

## MOUNTAIN HARDWARE

GPS MULTIFUNCTION BOARD . . . 199.00  
ROMPLUS W/ KEYBOARD FILTER . . . 179.00  
ROMPLUS W/O KEYBOARD FILTER . . . 130.00  
KEYBOARD FILTER ROM . . . 49.00  
COPYROM . . . 49.00  
MUSIC SYSTEM . . . 369.00  
ROMWRITER . . . 149.00  
APPLE CLOCK . . . 252.00  
A/D + D/A . . . 299.00  
EXPANSION CHASSIS . . . 825.00  
RAMPLUS 32K . . . 149.00

## CORVUS

### FOR S-100, APPLE OR TRS-80 MOD I, III

Controller, Case/P.S., Operating System, A & T	
5 MEGABYTES	3245.00
10 MEGABYTES	4645.00
20 MEGABYTES	5545.00
MIRROR BACK-UP	725.00

## CALIF. COMPUTER SYSTEMS

### S-100 BOARDS

2200A MAINFRAME	459.00
2065C 64K DYNAMIC RAM	539.00
2422 FLOPPY DISK CONT. & CP/M*	359.00
2710 FOUR SERIAL I/O	279.00
2718 TWO SERIAL/TWO PARALLEL I/O	269.00
2720 FOUR PARALLEL I/O	199.00
2810 Z-80 CPU	259.00

### APPLE BOARDS

7710A ASYNCHRONOUS S. INTERFACE	149.00
7712A SYNCHRONOUS S. INTERFACE	159.00
7424A CALENDAR CLOCK	99.00
7728A CENTRONICS INTERFACE	105.00

## VISTA COMPUTER CO.

APPLE VISION 80-80 COL CARD	329.00
APPLE 8" DISK DRIVE CONTROLLER	549.00

## MODEMS

NOVATION CAT ACOUSTIC MODEM	135.00
NOVATION D-CAT DIRECT CONNECT	156.00
NOVATION AUTO-CAT AUTO ANS	219.00
NOVATION APPLE-CAT	325.00
UDS 103 LP DIRECT CONNECT	175.00
UDS 103 JLP AUTO ANS	209.00
HAYES MICROMODEM II (APPLE)	289.00
HAYES 100 MODEM (S-100)	325.00
HAYES SMART MODEM (RS-232)	227.00
HAYES CHRONOGRAPH	199.00
LEXICON LEX-11 MODEM	109.00

## TERMINALS

TELEVIDEO 910	639.00
TELEVIDEO 912C	745.00
TELEVIDEO 920C	830.00
TELEVIDEO 950C	995.00
ADDS-VIEWPOINT	599.00

## TRS-80 MOD I HARDWARE

PERCOM DATA SEPARATOR	27.00
PERCOM DOUBLER II	159.00
TANDON 80 TRACK DISK DRIVE	345.00
TANDON 40 TRACK DISK DRIVE	289.00
LNW DOUBLER W/ DOSPLUS 3.3	138.00
MOD III DRIVE KIT	615.00

## MORROW DESIGNS

### FLOPPY DISK SYSTEMS

Controller, P.S., Microsoft Basic, CP/M*	
A & T	
DISCUS 2D (Single Drive — 500K)	1075.00
DISCUS 2D (Dual Drive — 1 MEG)	1695.00
DISCUS 2 + 2 (Single Drive — 1 MEG)	1777.00
DISCUS 2 + 2 (Dual Drive — 2 MEG)	2317.00

### HARD DISK SYSTEMS

Controller, P.S., Microsoft Basic, CP/M*	
A & T	
DISCUS M10 (10 Megabytes)	3345.00
DISCUS M26 (26 Megabytes)	4045.00

## ISOLATORS

ISO-1 3-SOCKET	53.95
ISO-2 6-SOCKET	53.95

## BARE DRIVES

TANDON 5 1/4 INCH	
100-1 SINGLE HEAD 40 TRK	209.00
100-2 DUAL HEAD 40 TRK	275.00
100-3 SINGLE HEAD 80 TRK	275.00
100-4 DUAL HEAD 80 TRK	399.00

### TANDON THINLINE 8 INCH

848-1 SINGLE SIDE	420.00
848-2 DUAL SIDE	515.00

## MICRO PRO

### APPLE CP/M\*

WORDSTAR*†	222.00
SUPERSORT*†	145.00
MAILMERGE*†	79.00
DATASSTAR*†	179.00
SPELLSTAR*†	119.00
CALCSTAR*†	149.00

### CP/M\*

WORDSTAR	285.00
SUPERSORT	168.00
MAILMERGE	103.00
DATASSTAR	235.00
SPELLSTAR	155.00
CALCSTAR	199.00

## MICROSOFT

### APPLE

FORTRAN*	150.00
BASIC COMPILER*	315.00
COBOL*	550.00
Z-80 SOFTCARD	299.00
RAMCARD	149.00
TYPING TUTOR	17.95
OLYMPIC DECATHLON	24.95
TASC APPLESOFT COMPILER	145.00

### CP/M\*

BASIC 80	299.00
BASIC COMPILER	319.00
FORTRAN 80	345.00
COBOL 80	568.00
MACRO 80	189.00
mu MATH/mu SIMP	215.00
mu LISP/mu STAR	165.00

## APPLE SOFTWARE

MAGIC WINDOW	79.00
MAGIC SPELL	59.00
BASIC MAILER	59.00
DB MASTER	169.00
DB MASTER UTILITY PACK	59.00
DATA CAPTURE 4.0/80	59.95
PFS GRAPH	89.95
PFS (NEW) PERSONAL FILING SYSTEM	85.00
PFS: REPORT	79.00
Z-TERM*	89.95
Z-TERM PRO*	129.95
ASCII EXPRESS	63.95
EASY WRITER-PRO	199.00
EASY MAILER-PRO	79.00
EXPEDITER II APPLESOFT COMPILER	73.95
A-STAT COMP. STATISTICS PKG	129.00
SUPER TEXT II	129.00
LISA 2.5	59.95

## CONTINENTAL SOFTWARE

G/L	199.00
A/R	199.00
A/P	199.00
PAYROLL	199.00
PROPERTY MGMT	399.00
THE HOME ACCOUNTANT	59.95

## VISICORP

DESKTOP PLAN II	189.00
VISIPLLOT	158.00
VISITREND/VISIPLLOT	229.00
VISIDEX	189.00
VISITERM	79.00
VISICALC	189.00
VISIFILES	189.00

## CP/M\* SOFTWARE

THE WORD-SPELL CHECK	75.00
d BASE II	599.00
SUPER CALC	209.00
SPELLGUARD	239.00
P & T CP/M* MOD II TRS-80	175.00
COMM TERMINAL PROG	82.50
C BASIC 2	115.00
PASCAL 2	349.00
PASCAL MT +	439.00
PASCAL/M	205.00
SYSTEMS PLUS —	
G/L, A/R, A/P, P/R	1799.00
CONDOR I	579.00
CONDOR II	849.00

## DIGITAL RESEARCH

MAC	89.00
-----	-------

SID	69.00
ZSID	97.00
PL/1-80	439.00

## SUPERSOFT

DIAGNOSTIC I	69.00
DIAGNOSTIC II	89.00
'C' COMPILER	179.00
UTILITIES I	59.00
UTILITIES II	59.00
RATFOR	89.00
FORTRAN	239.00

## TRS-80 GAMES

TEMPLE OF APSHA	34.95
HELLFIRE WARRIOR	34.95
STAR WARRIOR	34.95
RESCUE AT RIGEL	24.95
CRUSH, CRUMBLE AND CHOMP	24.95
INVADERS FROM SPACE	17.95
PINBALL	17.95
STAR TREK 3.5	17.95
MISSILE ATTACK	19.95
STAR FIGHTER	24.95
SCARFMAN	17.95

## TRS-80 SOFTWARE

NEWDOS/80 2.0 MOD I, III	139.00
LAZY WRITER MOD I, III	165.00
PROSOFT NEWSSCRIPT MOD I, III	99.00
SPECIAL DELIVERY MOD I, III	119.00
X-TRA SPECIAL DELIVERY MOD I, III	199.00
TRACKACCESS MOD I	24.95
OMNITERM SMART TERM MOD I, III	89.95
MICROSOFT BASIC COMP. FOR MOD I	165.00
LDOS 5.1 MOD I, III	159.00

## APPLE GAMES

### PERSONAL SOFTWARE

CHECKER KING	21.95
GAMMON GAMBLER	21.95
MONTY PLAYS MONOPOLY	29.95

### BRODERBUND

GALAXY WARS	20.95
ALIEN TYPHOON	20.95
APPLE PANIC	24.95
MIDNIGHT MAGIC	29.95
SPACE QUARKS	24.95

### AUTOMATED SIMULATIONS

INVASION ORION	20.95
STAR WARRIOR	32.95
TUES MORNING QUARTERBACK	25.95
CRUSH, CRUMBLE AND CHOMP	24.95
THE DRAGON'S EYE	20.95

### MUSE SOFTWARE

ROBOT WARS	32.95
THREE MILE ISLAND	32.95
A.B.M.	20.95
GLOBAL WAR	20.95
CASTLE WOLFENSTEIN	24.95

### ON-LINE SYSTEMS

WIZARD AND PRINCES	29.95
MISSILE DEFENSE	25.95
SABOTAGE	20.95
SDFIT PORN ADVENTURE	24.95
THRESHOLD	31.95
JAW BREAKER	24.95
CROSSFIRE	24.95
TIME ZONE	69.95

H/R FOOTBALL	32.95
H/R CRIBBAGE	20.95
PEGASUS II	25.95

## SIRIUS SOFTWARE

SPACE EGGS	24.95
GORGON	32.95
SNEAKERS	24.95
EPOCK	29.95
BEER RUN	24.95
HADROM	29.95
PULSAR II	24.95
EPOCK	29.95

## EDU-WARE

PERCEPTION PKG	19.95
COMPU-READ	24.95
COMPU-MATH ARITHMETIC	39.95
COMPU-MATH FRACTIONS	34.95
COMPU-MATH DECIMALS	34.95
COMPU-SPELL (REQ DATA DISK)	24.95
COMPU SPELL DATA DISKS 4-8, ea.	17.95

## MORE GREAT APPLE GAMES

COMPUTER QUARTERBACK	32.95
TORPEDO FIRE	49.95
THE SHATTERED ALLIANCE	49.95
POOL 1.5	28.95
ULTIMA	33.95
RASTER BLASTER	24.95
FLIGHT SIMULATOR	27.95
INTERNATIONAL GRAND PRIX	25.95
SARGON II	28.95
SHUFFLE BOARD	29.95
FIREBIRD	24.95
SNACK ATTACK	24.95
THIEF	24.95
ROACH HOTEL	29.95
JABBERTALKY	24.95
THE WARP FACTOR	32.95
COSMO MISSION	24.95
WIZARDRY	37.95
ZORK I	32.95
ZORK II	32.95

## SUPPLIES

### AVERY TABULABLES

1,000 3 1/2 x 15/16	8.49
3,000 3 1/2 x 15/16	14.95
5,000 3 1/2 x 15/16	19.95

## FAN FOLD PAPER

(Prices F.O.B. S.P.)

9 1/2 x 11 18lb WHITE 3,000 ct	29.00
14 7/8 x 11 18lb WHITE 3,000 ct	39.00

# Alpha Byte COMPUTER PRODUCTS

To order or for information call  
**(213) 706-0333**  
Modem order line: (213) 883-8976

We guarantee everything for 30 days. If anything is wrong, return the item and we'll make it right. And, of course, we'll pay the shipping charges.

We accept Visa and Master Card on all orders; COD up to \$300.00.

Add \$2.00 for standard UPS shipping and handling on orders under 50 lbs, delivered in continental U.S. Call for shipping charges over 50 lbs. Foreign, FPO and APO orders, add 15% for shipping. Californians add 6% sales tax.

Prices quoted are for stock on hand and subject to change without notice.

31245 LA BAYA DRIVE, WESTLAKE VILLAGE, CALIFORNIA 91362

## The Epson QX-10/Valdocs System

---

Gregg Williams  
Senior Editor

---

These are wonderful days for people who need computers. Microcomputers that do more and more are becoming available—and, paradoxically, they are becoming *less* expensive. The only trouble is that, between the time you order a unit and it is delivered, something better is announced (but you *know* it will be six months to a year before the new unit will be available).

As the saying goes, I've got bad news and good news. The bad news is that, yes, another wonderful computer is about to come out—from Epson, the company that has captured about 75 percent of the printer market. The good news is that the unit is supposed to be available by this Christmas. On the basis of Epson's track record, I believe they'll do it.

BYTE was one of the few companies to be given a private showing this past summer of the Epson QX-10, a computer for less than \$3000 that may well be the first of a new breed of anybody-can-use-it "appliance" computers. Chris Rutkowski, president of Rising Star Enterprises (a consulting firm that works closely with Epson), showed me the QX-10, along with a preliminary version of an extended word processor called Valdocs and an enhanced keyboard design called HASCI, both designed by his company. As you'll be able to tell from this article, I found them both very interesting.

### QX-10 Hardware

For its retail price of less than \$3000, the QX-10 (see photo 1) gives you a great deal for your money. It contains a Z80 microprocessor running at 4 megahertz (MHz), 128K bytes of memory (expandable to 256K bytes), two direct memory access (DMA) controllers, one

free serial port (a second one is used by the keyboard), a Centronics-compatible parallel port, six clock-timers, 2K bytes of battery-powered complementary metal-oxide semiconductor (CMOS) memory (to hold certain information even when the computer is turned off), a CMOS clock/calendar, and a light-pen interface. The unit also contains two thinline 5¼-inch floppy-disk drives, each double-sided and double-density, with 40 tracks per inch; each drive holds 320K bytes. The video display, based on the NEC 7220 graphics chip, includes a 32-MHz medium-persistence video monitor and 128K bytes of dedicated video memory (shown as the bottom board in photo 2). The video display will work in either a 25-line by 80-character text mode or a 640- by 400-pixel graphics mode. The QX-10 comes with one of two detachable keyboards—standard-layout or HASCI—more on that later. Finally, the QX-10 has internal space for up to five peripheral cards like those used by the Apple, Corvus, and IBM microcomputers.

### QX-10 Configurations

The QX-10 will be sold in two configurations. The first includes (at the time of this writing) the QX-10 as described above, the standard-layout keyboard, the CP/M operating system, Microsoft BASIC, and STOIC (a fast, extensible FORTH-like language). This version is a standard CP/M-based microcomputer for those of us who are comfortable with microcomputers as we know them today.

However, the QX-10 was really designed for the average consumer, who *isn't* comfortable with microcomputers as we know them today. With the software included in this package, the QX-10 becomes (as Ep-





Photo 1: The Epson QX-10/Valdocs system.

son puts it) a *symbol processor* that anyone can use. This configuration of the QX-10 includes the hardware as described above, the HASCI keyboard, the Valdocs software, TP/M (a CP/M equivalent with its own enhancements), Microsoft BASIC, and STOIC. (CP/M may be offered in place of TP/M, but the configuration will probably be very close to the one listed above.)

### The Epson Philosophy

Although Epson will certainly sell you the CP/M version of the QX-10, it is far more interested in selling you the unit it really designed—hardware and software designed *in conjunction with each other* to offer both high performance and ease of use. In addition to being a highly integrated word-processing/computer system that offers as much usable processing power as almost any existing microcomputer, the QX-10/Valdocs system is designed to be used without confusion by people with minimal technical knowledge. We've certainly heard that claim before, but Epson has delivered on this promise in a way and to an extent that *no* microcomputer manufacturer has done.

The Valdocs (short for "valuable documents") system described here is designed to manipulate what Epson sees as the four types of symbols that people use: letters,

numbers, graphics, and time. The HASCI keyboard (scheduled to be described next month by Chris Rutkowski in his article "An Introduction to the Human Applications Standard Computer Interface") is shown in photo 3. It is designed with a set of function keys that relate directly to the most common operations people perform on symbols. In addition, these keys are designed to be sufficient to drive any future symbol-manipulating software—that way, the keyboard layout won't change even when more sophisticated software is developed. Table 1 gives a brief description of the HASCI keyboard function keys.

Another aspect of the Epson philosophy is its commitment to ensure that all the parts of a system work together. (What's amazing is that the microcomputer industry has survived while blatantly ignoring this philosophy.) In the QX-10 (with or without Valdocs), the computer, its software, and its peripherals are meant to use each other's capabilities to the fullest. This goes hand in hand with Epson's vision of the dot-matrix printer as the universal standard for printing. Epson has designed a line of printers that act identically and are capable of printing both bit-mapped graphics and text in varying degrees of quality (draft-, correspondence-, and—with some future printer—letter-quality printing).

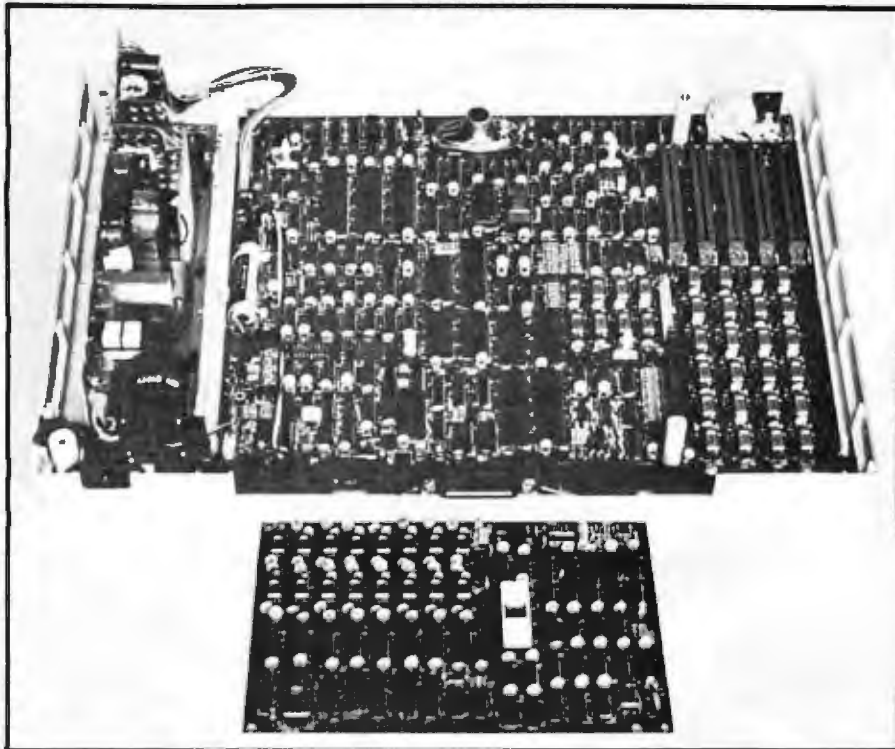

Photo 2: Inside the Epson QX-10. The top unit is the motherboard of the QX-10; the rear of the unit is closest to the camera. The connectors in the upper right corner are the five slots for peripheral cards. The smaller board (below the motherboard) contains the 128K bytes of video-display memory; this card fits on top of the motherboard in the assembled unit.

### Valdocs

Epson wants the average person to be able to buy a QX-10/Valdocs system in a department store, plug it in, turn it on, and be able to type in a letter without having to read more than the unpacking instructions. Based on

my inspection of a preliminary version of the Valdocs software, I believe that this is a realistic view of the system. Although I can't do a full review of the software based on the short amount of time I spent with the system, I do want to point out several unique features of the QX-10/Valdocs combination.

Help is available at any time through the HASCI keyboard Help key. An extensive text file of instructions is on the Valdocs system disk and can be read by pressing the Help key. This key gives you a menu of subjects that might be of interest (based on what you were doing when you pressed Help), as well as access to the entire Help file via user-entered keywords. Of course, the QX-10 returns to wherever you were before the Help key was pressed.

The Valdocs symbol processor can manipulate any of the four types of symbols at any time. Text can be entered at any time just as you would in any conventional word processor. The Calc key turns the system into a basic 4-function calculator. Graphics

can be created via the Draw key. The Sched (schedule) key gives you access to a computer-kept appointment book, a built-in clock/timer/alarm, and an event scheduler; all these can be accessed without disturbing the file being edited.



Photo 3: The HASCI keyboard for the Epson QX-10/Valdocs system.

The operation of all keys is as intuitive as possible. For example, when you use any of the type-font keys (Bold, Italic, Size, or Style), the video text image changes to reflect the use of those keys. When you hit the Italic key, all your subsequent typing appears on the screen as italics until you hit the key again to turn italics off. Also, keys like left-arrow, right-arrow, and Delete do their respective functions to words and lines (instead of individual characters) when used with the Word and Line keys.

It is impossible to make any major destructive change to your file without having the change explained to you and being asked to confirm it. In addition, the Undo key allows you to recover from the last major change made to the file.

The Valdoks system supports telecommunications and electronic mail in a way that is transparent to the user (through the Mail key, of course). You can be connected to the remote user by either a modem-telephone combination or a local network (probably the Corvus Omninet). Valdoks includes software that allows you to send and receive mail and access remote bulletin boards and databases.

The Valdoks file system is one example of the kind of levelheaded philosophy that is embodied everywhere in the Valdoks symbol processor. When you store a file, you give it a name of up to eight words—for example, "Letter, 8/13/82, to Bob Jackson; new rate schedule." When you hit the Index key, you can get a listing of all your files in one of several ways—sequentially, alphabetically, or by match of a given word to any keyword in any file. Using the last method of indexing, I could get a listing of all documents that are letters, all documents done on 8/13/82, or all documents that refer to a person named Bob. In addition, all documents are chosen by menu selection (so you don't have to type in a long file name). The utter sanity of this in comparison to file names like L081382.LTR is astounding.

One interesting technical note: to interactively create such a sophisticated word processor with the given time constraints, the Valdoks programmers used the STOIC language (a public-domain variant of FORTH created at the Biomedical Engineering Center of the Massachusetts Institute of Technology and Harvard University) to program the Valdoks symbol processor. It is a testament to the power of STOIC (and other threaded languages) that it was used to create a project of this scale.

### New Products

Given the enhancements being planned, it may be that Valdoks is not so much a product as it is a design that Epson will always be improving. Epson plans to have version 2.0 of the Valdoks software available by mid-1983 (updates will be supplied at cost to owners of the QX-10/Valdoks system). Plans are under way for a color interface board and an Omninet interface board (for local networking). Epson is also considering such enhancements as higher-resolution graphics and additional graphics-oriented peripherals, as well as a portable version of Valdoks and perhaps a 16-bit system.

#### System Controls

- Stop—pauses whatever is occurring at the moment, letting you either resume or abort the operation.
- Help—lets you select and read parts of the disk-based Help file.
- Copy disk—lets you make a copy of a given floppy disk.
- Undo—undoes the last major destructive action.

#### File Controls

- Store—lets you save what you are working on to disk.
- Retrieve—lets you retrieve a file from disk.
- Print—lets you print a file.
- Index—allows you to see what files are on a floppy disk.
- Mail—allows you to send or receive a file electronically.

#### Applications

- Menu—gives you access to miscellaneous functions.
- Calc—gives you a 4-function calculator.
- Sched—gives you access to the scheduling functions of Valdoks.
- Draw—lets you draw graphics on the video display.

#### Typetypes

- Bold—toggles typeface between boldface and normal type.
- Italics—toggles typeface between italics and normal type.
- Size—lets you change the size of the type currently being used.
- Style—lets you change the typeface of the type currently being used.

Table 1: A brief description of the function keys on the top row of the HASCI keyboard.

One enhancement to the QX-10/Valdoks system that Chris Rutkowski did describe is the Valdoks FPL (Forms Processing Language). This is an additional software package that would give the user access to a spreadsheet package, a forms generator that would generate records from keyboard input, and a report generator that would create reports based on a database of records. As usual with ideas from Rising Star, the Valdoks FPL package is actually more than it seems—the spreadsheet and the form into which data is typed are actually the same thing, and a record of data can automatically be created from the spreadsheet. This is a new concept that combines spreadsheet forecasting, online data entry, and database management. It sounds exciting and I am looking forward to seeing it at work.

### Final Thoughts

From what I have seen, Epson has created an enhanced personal word-processing system that *can* be (and is more likely to be) used by the person with minimal technical knowledge. Almost every microcomputer company claims that its product can be used by anybody, but many people (even those with technical knowledge) still have trouble getting started in personal computing. As microcomputers become more powerful, easier to use, and less expensive, the claim that "anyone can use it" will become true in a fuller and fuller sense, making previous claims seem naive and hollow. Still, the Epson QX-10/Valdoks system may become the first microcomputer that "really" fulfills that claim. BYTE will report to you again when the final unit becomes available. ■

# NCC Report

by **Chris Morgan**

Sensory overload.

How else do you describe the world's biggest computer exposition? It was the National Computer Conference, held this June in Houston, Texas, and it drew a crowd of nearly 100,000.



The new Hitachi miniature floppy-disk system in a version to be marketed by the Amdek Corp. The floppy-disk cartridge, shown at right, is slightly more than 3 inches wide. Compare it to the standard 5 1/4-inch floppy disk, shown at left.

The new Syquest miniature Winchester disk drive with removable media cartridge. Each cartridge holds 6.38 megabytes, unformatted. The unit is expected to sell for \$750 in single-user quantities within the year. The cartridges will sell for about \$35 each.



Photos by Gregg Williams, senior editor,  
and Richard Shuford, special projects editor.

Olivetti's new M 20 microcomputer.



The Commodore series B microcomputer.

I've been attending the NCC for five years, and until this year microcomputers stayed in the background, playing a secondary role to mainframe computers. But this year the microcomputers came into their own, reflecting **Business Week's** recent projected figures showing microcomputers accounting for up to over 40 percent of the total computer market by 1985. A case in point, Apple's booth was the same size as IBM's, and it was attracting just as many visitors. Microcomputers have become indigenous to

the NCC. Nearly as indigenous are the sore feet that come from trying to see several football fields' worth of booths in four short days.

The big question is, were there many surprises? No. And of equal importance, were there any signs of the beginnings of important trends? Yes.

Of surprises there were few; no bombshells on the order of last summer's unveiling of the IBM Personal Computer. Instead, the microcomputer software and hardware companies appeared to be carefully con-

solidating their positions, strengthening their distributorships, carefully evolving their product lines, and paying more attention to the needs of their customers. It was, in a sense, a much needed lull in the furious storm of research-and-development work, the fruits of which we'll see next year and beyond. Still, there was plenty to see this year.

#### **Mass Storage**

Suddenly, the miniature floppy-disk drive is upon us. Announce-



Cromemco's new C-10 computer system.

Visicorp's new Visicalc Advanced Version.

ments of new drives came from a trio of Japanese companies—Matsushita (Panasonic division), Hitachi, and Maxell—who are all pushing one format. As well, Canon announced its plans for a different, noncompatible format. This news follows on the heels of Sony's miniature 3-inch drive, which is already in production. Amdek Corporation, an American company, announced it is adopting the Matsushita design for its new miniature floppy-disk drive. All three noncompatible formats have miniature cassettes to hold the floppy medium, and they have double-density unformatted capacities of 80K bytes for the Canon, 437.5K bytes for the Sony, and 500K bytes for the Matsushita. Each standard miniature floppy disk calls for a cartridge 4 by 4 inches or smaller and less than 0.5 inch thick. Sinclair has also announced a miniature drive for its new Spectrum computer.

One of the most exciting announcements at the show was from Syquest. It's a 3.9-inch Winchester disk drive with removable media. Each cartridge holds 6.38 megabytes, unformatted. The surprise is its selling price: about \$750 in single-user quantities within the year! This does not include the controller. Even so, inexpensive controllers are now available, making this a very attractive design. The entire unit fits in the space of a standard 5¼-inch floppy-disk drive. (It's actually shallower, with a vertical dimension of 1.625 inches.) The car-

tridges will sell for about \$35 each. The secret to the low price: clever use of plated-media technology. We'll be reporting on this new technology in an upcoming issue.

Tandon Corporation announced a slim-line 5¼-inch floppy-disk drive for \$50 (for quantities in the thousands of course), for the mechanical parts only. The company will provide customers with schematics and drawings to build their own electronics if they wish. It's an encouraging sign that prices will soon be dropping in the mass-storage market.

### New Processors

Intel announced two new important integrated circuits: the 80186 and the 80286. Picture an 8086 with faster clock speed, some new instructions, and the equivalent of 20 auxiliary chips all on one VLSI (very large-scale integration) package for a single-user price (ultimately) of \$35, and you have the 80186. It's the closest thing yet to a complete

computer on a chip. The 80286 chip extends the idea of the 80186 to include built-in memory management and protection and a virtual address space of 1 gigabyte.

### Systems

Olivetti introduced its new computer, the M 20, with a Z8001 processor, a 5-slot expansion bus, space for two 5¼-inch floppy-disk drives, and up to 128K bytes of memory. It's one of the more handsome units we saw at the conference, true to Olivetti's style. The operating system is Olivetti's own, called PCOS, and the machine will support Microsoft BASIC 5.2.

Commodore announced several new machines. The BX256 is a 16-bit, multiprocessor computer with 256K bytes of RAM (random-access read/write memory), extendable externally to 640K bytes, two processors (a 6509 and an 8088 for CP/M-86), an 80-column black-and-white video monitor, and a detachable keyboard. A three-voice music



synthesizer is also included, which uses the new 6581 microprocessor chip. An optional plug-in Z80 board is also available. Price is \$2995. The business-oriented B128 offers features similar to the BX256's.

Another computer, the P128A, has 128K bytes of RAM, a 40-column by 25-line 16-color display, and a high-resolution 300- by 200-pixel display. It connects directly to either a video monitor or a color television set and sells for \$995. An optional Z80 board for use with CP/M is also available.

The Commodore 64 offers 64K bytes of RAM, color graphics, and music synthesis for \$595. A Z80 board can be added to run CP/M programs. The screen is 40 columns wide by 25 lines down, and the processor is the new 6510, which is similar to the 6502 with additional I/O (input/output) lines. Commodore gets the prize for the wildest styling of any computers we saw at the show.

Cromemco's new \$1785 C-10 is a complete hardware/software system featuring a 4-MHz (megahertz) Z80A, 64K bytes of RAM, a 12-inch 80-character by 25-line display, double-sided double-density 5¼-inch floppy-disk drive, detachable keyboard, CP/M-compatible operating system, structured BASIC, a word processor, and a spreadsheet program.

### Son of Visicalc

Visicorp announced the long-awaited successor to Visicalc. It's called Visicalc Advanced Version. For \$400 you get a souped-up version of the most popular software package in the field. Many of the best features found in competing spreadsheet programs have been incorporated into Visicalc Advanced Version. As well, it has greatly expanded help files to aid the computer novice.

Its new features include protected cells to prevent accidental loss or change of information, hidden cells to protect sensitive information, a new tab feature to guide users from one space to the next, more formatting flexibility, variable column



NEC's new APC (Advanced Personal Computer) executing a color-based spreadsheet program.

widths, keystroke memory to repeat frequently used commands, and more. Visicalc Advanced Version is compatible with the original Visicalc, which will still be sold for those who prefer it. Dan Fylstra, chairman of Visicorp, said that one of his goals in creating Visicalc Advanced Version was to make the program more of a "black box" for nontechnically oriented users so that they won't be distracted by unnecessary information. To that end, much of the instruction manual has been incorporated into the program's help files.

### Software Trends

I saw the beginnings of two trends being followed by some of the biggest software producers—Visicorp, Microsoft Consumer Products, and Software Arts (creator of Visicalc and the TK Solver equation-solving package mentioned in last month's editorial). All three companies have developed programs that make use of enormous disk-based help files. By making help about the program available literally at the touch of a button, these manufacturers hope to make their programs easier to use. Another interesting move is toward the use of high-level computer languages to develop products that are easily transportable among various machines. Visicorp and Microsoft

Consumer Products are using the C language, while Software Arts has developed its own proprietary language for in-house use. All three companies develop software on mainframe computers that have extensive diagnostic and performance evaluation features, and then they move the finished programs to microcomputers.

### NEC's Advanced Personal Computer

NEC Information Systems Inc. showed its 8086-based Advanced Personal Computer (APC). The APC is available in two configurations—a monochrome configuration that includes CP/M-86, 128K bytes of memory, and two 8-inch 1-mega-byte drives (\$3998) and a color configuration that substitutes a 12-inch RGB (red-green-blue) color monitor for the monochrome monitor (\$4998). The color-based unit is impressive: over 300K bytes of memory are used to give an 8-color 640- by 475-pixel display with no limitations on adjacent pixel colors. The actual graphics display is 1024 by 1024 pixels, and the video display is a movable window within that area. NEC has already lined up a comprehensive array of business software packages for its machine, something that's sure to continue as competition quickens and the industry matures. ■

# The Hanover Fair

by Robert E. Ramsdell

With nearly 9 million square feet of total exhibit space, individual displays the size of a football field, and close to 600,000 visitors, the Hanover Industrial Trade Fair and Exposition is the world's largest. Held this year from April 21 to 28 in Hanover, West Germany, this fair is a showcase for hundreds of manufacturers of office equipment and computers.

CeBIT, the world center for office equipment and data processing, had a display that covered 1.75 million square feet (about 20 percent of the total area) and spilled over into 5 buildings. To give you some idea of the scale of things in Hanover, CeBIT's space alone was about five times greater than that of America's largest computer show, the annual

National Computer Conference held this year in June in Houston, Texas.

Some 178 U.S. companies were part of the CeBIT display. The United States Department of Commerce sponsored a group pavilion there. Among the 60 companies from the U.S. that joined together to exhibit their products in the European marketplace were Fortune, Corvus, Altos, Beehive, Durango, MIA-COM (Ohio Scientific), Micom, Morrow, and Televideo. In addition, Osborne, Tandy, Apple, Xerox, IBM, Centronics, Cromemco, Data General, Digital Equipment Corporation, Micropro, NCR, Burroughs, Texas Instruments, Prime, Shugart, Tandem, Teleram, Vector Graphic, Victor, and more had booths elsewhere in the show. On public display were

anywhere from 73 to 95 different computer models; the count depended on whom I asked.

More than 30 Japanese computer manufacturers exhibited, and some of their booths were three stories tall. The Japanese showed many new (and slightly revamped) computer models, including about 20 16-bit machines, most of which run Microsoft's MS-DOS. The Intel chips (8086/8088) seemed to dominate these computers, but several models used the Motorola 68000.

To cope with the huge crowds attending the Hanover fair, the city of Hanover has established a private-room registry, with offices at the airport, train station, and the fair itself. The registry guaranteed a room, usually in a private home, to all visitors and exhibitors. Many Americans at the fair agreed that staying in a private home was a great cultural experience as well as a delightful and inexpensive way to absorb the German atmosphere and the **gemutlichkeit** (friendliness) of the German people. The language barrier never seemed to be a problem, either at the fair or around the city. ■

Pentel's new computer.



---

Robert E. Ramsdell, CPA, is a microcomputer consultant who lives and works in Rockport, Massachusetts. His company, Pansophics Ltd., publishes business- and financial-modeling applications software for use with Visicalc and Supercalc programs.

---





**A new business computer from Toshiba.**



**An unusually styled computer from Olympus.**



**Another Japanese entry, from Sanyo.**



**The Epson HX-20 portable computer.**

## Build the Microvox Text-to-Speech Synthesizer

### Part 1: Hardware

*The 6502 microprocessor in this intelligent peripheral device translates plain English text into phonemes to control a Votrax SC-01A.*

---

Steve Ciarcia  
POB 582  
Glastonbury, CT 06033

---

This month's project may have a strange ring of familiarity to those of you who follow my activities in the Circuit Cellar. Twice before, in June and September of last year, I have written about peripheral devices that give personal computers the ability to speak with an imitation of a human voice.

The September article (see reference 5) described the Sweet Talker speech synthesizer, which has since become especially popular. The original Sweet Talker, a parallel-interfaced synthesizer module programmed by phoneme (speech sound) codes, was quickly joined by a version that could be plugged into an

Apple II computer and operated using a text-to-speech algorithm stored on a floppy disk.

But I wasn't satisfied. Neither the Sweet Talker nor my June project (see reference 4), the Micromouth, was flexible enough to fit the variety of applications I had envisioned. I could foresee applications requiring unlimited vocabulary (thus ruling out use of the Micromouth) that also need a smaller, more portable voice-synthesis system than could be made out of an Apple II. While I was content with the Sweet Talker's speech quality, I did not want to try converting the text-to-speech algorithm to run on my Z8-BASIC Microcomputer.

I next considered using the Votrax Type-N-Talk. As a stand-alone voice synthesizer with a built-in microprocessor and 4K-byte text-to-speech algorithm, it does quite well considering its moderate cost (see reference

#### General-Purpose Computer

*The 6502-based microcomputer that forms an integral part of the Microvox is ideal for use in many other small-scale applications. Only the application software and the interface to the SC-01A chip are specific to the microcomputer's use in the stand-alone text-to-speech voice synthesizer. If you are among the many readers who write to me asking for suggestions on how to put together a low-priced, general-purpose microcomputer system, you should consider building the computer part of the Microvox design.*

*The computer section contains, among other things, a 1-MHz 8-bit 6502 microprocessor, a serial input port that can run at crystal-controlled data rates from 75 to 19,200 bps (bits per second) with full handshaking, 3*

*parallel input ports, provision for up to 4K bytes of RAM (random-access read/write memory) and 16K bytes of EPROM (erasable programmable read-only memory), and an on-board power supply. It is suitable for use as a learning tool for computer concepts, as a dedicated device controller, or as the center of an expanded microcomputer system (similar to systems that have been built around the MOS Technology KIM-I or the Rockwell AIM-65).*

*The Micromint will be supplying essential components of the microcomputer section of the Microvox for those who wish to experiment with it. And you may expect to see the same 6502-based control-computer design in future Circuit Cellar projects.*

---

Copyright © 1982 Steven A. Ciarcia.  
All rights reserved.

---

*Type-N-Talk and Votrax are trademarks of Federal Screw Works.*

---

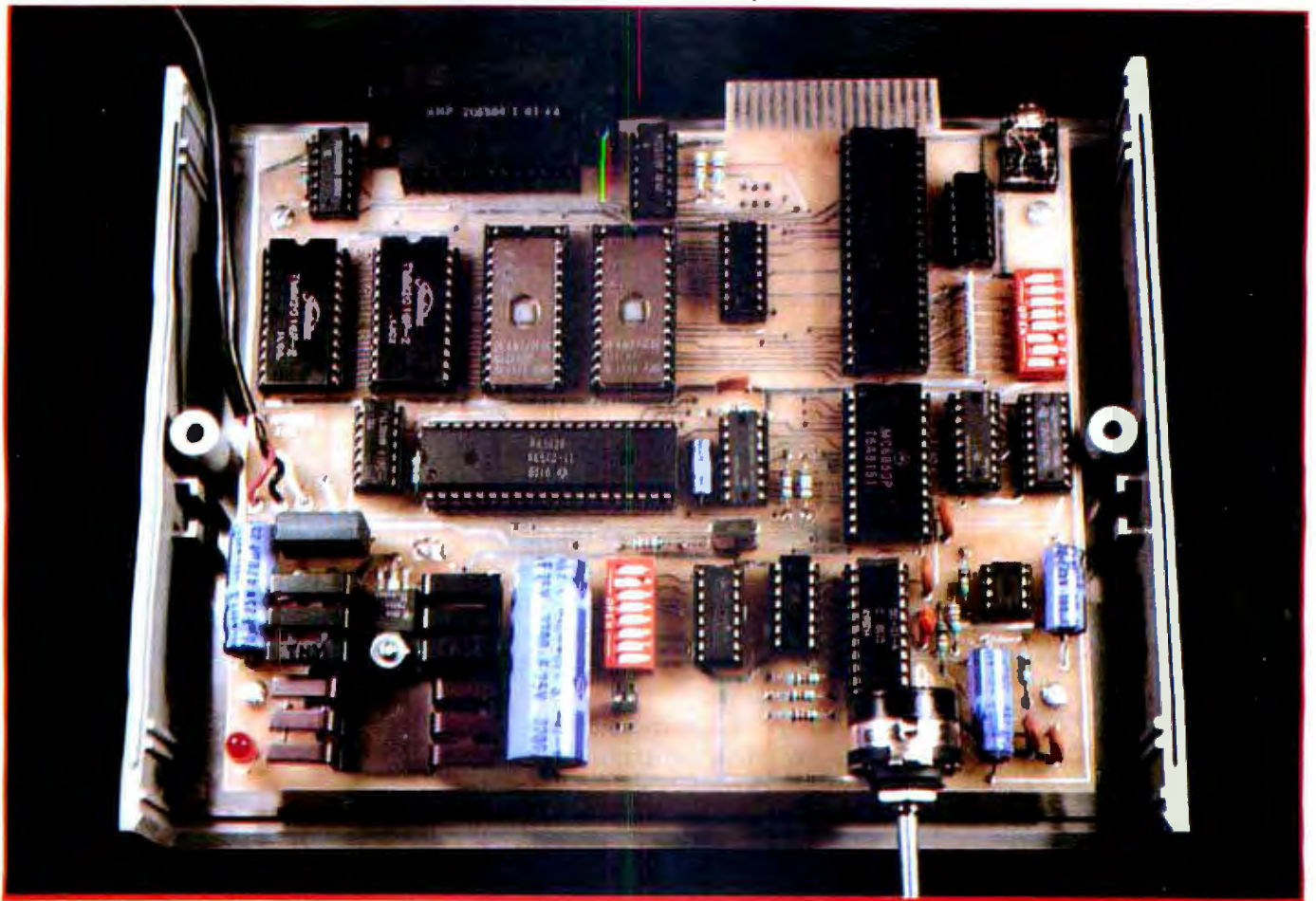

**Photo 1:** Prototype of the Microvox speech synthesizer, which can pronounce texts consisting of English words from their representation as ASCII characters according to fixed pronunciation rules. The Microvox contains a general-purpose 6502-based microcomputer programmed to control the Votrax SC-01A-based speech-synthesis circuitry.

12). However, its design is somewhat limited for commercial applications.

Not finding any other suitable product on the market, I did what any red-blooded engineer would naturally do: I decided to design an improved text-to-speech voice synthesizer.

You are reading the first of two articles on the design, construction, and operation of a text-to-speech voice synthesizer I call the Microvox. This new device, like the Sweet Talker, is based on the Votrax SC-01A speech-synthesis integrated circuit, but it incorporates new functions (most notably pitch inflection) and a larger, more complex control program. A list of its features appears in table 1 on page 66.

To support its various functions, the Microvox contains a general-purpose 6502-based microcomputer programmed to control the speech-syn-

thesis circuitry. Program routines stored in ROM (read-only memory) activate various control options upon the user's command; the most complex of the routines performs the crucial task of translating the Microvox's input—a stream of text represented by ASCII (American Standard Code for Information Interchange) character codes—into the special phoneme codes required by the SC-01A chip. Incidentally, this 6502-based microcomputer is ideal for use in many other small-scale applications, as the text box explains.

As with many Circuit Cellar projects, the Microvox design has been cast in printed circuit, and I have arranged for The Micromint to offer a kit of the parts needed to build it. Furthermore, an assembled, FCC- (Federal Communications Commission) approved version of the unit is being sold by Intex Micro Systems Cor-

poration under the trade name Intex Talker. Information on availability of both products appears at the end of this article.

I cannot thoroughly cover such a comprehensive topic in one article, so this month I shall present only the hardware and a brief overview of the system commands. Next month in Part 2, I'll discuss the design of the text-to-speech algorithm and the system software.

Let's begin with an explanation of what we are trying to accomplish and a brief review of the Votrax SC-01A chip and phonetic speech synthesis in general.

### Text-to-Speech Background

Many articles in *BYTE* and other technical magazines have been devoted to the topic of computer speech synthesis. In general, they have dealt more with the production of the

1. Phoneme-based speech synthesis
2. 6502 control microprocessor
3. 64 crystal-controlled inflection levels
4. 1K-character buffer (optionally expandable to 3K)
5. 6K-byte plain-text-to-phoneme algorithm
6. Full ASCII character-set recognition and echo
7. Adjustable data rates (150 to 9600 bits per second)
8. RS-232C and parallel input interfaces
9. Phoneme access modes
10. Serial X-on/X-off software handshaking
11. User-expandable memory
12. 1-watt audio amplifier with volume control
13. On-board power supply
14. Music and sound effects

**Table 1: Major characteristics of the Microvox text-to-speech synthesizer (and of its alter ego, the Intex-Talker).**

**Code Function**

IK	synchronize speech and text
IL	line-by-line pronunciation
IW	whole-text pronunciation
IE	each-letter pronunciation
IC	pronounce by direct phoneme input
IT	pronounce by text-to-speech algorithm
IN	play musical notes
!A	pronounce all punctuation
!M	pronounce most punctuation
!S	pronounce some punctuation
!F	set monotone or flat intonation
!!	set automatically inflected intonation
IPx	set intonation base pitch (where x = 1 to 4)
IRy	set intonation clock rate (where y = 1 to 16)

**Table 2: An incomplete list of some of the control codes and sequences used by the Microvox, with their functions. Part 2 of this article will contain more detail concerning the Microvox's control capabilities.**

speech interface and the technology of specific synthesizers than with the applications to which speech synthesis may be put. Such treatment is similar to comparing computer systems by their processor instruction sets only instead of the high-level-language software available for them. Today, far more computer users are concerned with applications than

with construction of computers or peripheral devices. The Microvox is designed for easy use in a wide variety of applications.

With the majority of low-cost speech-synthesizer interfaces, the user must arrange for conversion of the material to be spoken from textual characters to data that the speech synthesizer can work with (phonemes, linear-predictive-coding formants, word codes, etc.). The difficulty of conversion depends largely on the size of the required vocabulary. For small vocabularies, a table of words and their corresponding synthesizer codes can be compiled with reasonable effort. When the required vocabulary becomes very large, all-inclusive tables become prohibitively cumbersome, and a generalized text-to-speech algorithm is required instead.

A text-to-speech algorithm is embodied in a program that accepts ASCII characters as input and performs a synthesis-by-rule analysis of character strings; that is, the algorithm interprets the characters as words or other elements of language and devises a scheme for pronouncing them according to a fixed set of rules that determine which characters are voiced, and in what way, and which characters are silent. The rules are based on how given combinations of characters are pronounced most of the time in English (or the language in use).

Text-to-speech programs vary in length depending upon the degree of exactness required in pronunciation. Typical algorithms use from 4K to 8K bytes of object code for most processors, but some of the more sophisticated programs need up to 80K bytes. (Often, half of an 80K-byte synthesis-by-rule routine consists of tables of words that are exceptions to the rules.)

The primary difference you can see between a 6K-byte and a 20K-byte program is how the input text must be spelled to obtain acceptable pronunciation; the final sound quality may be the same. Certain words may be spelled unusually to fit the prescribed pronunciation rules of the smaller algorithm. For instance, my name,

Ciarcia, is properly pronounced by most synthesizers (and by a lot of people, come to think of it) only when it is spelled "see-are-see-ah." The only other major differences are features such as pronunciation of punctuation or inflected speech. (Both of these capabilities are supported by the Microvox.)

**Strengths of Microvox**

While there are many speech-synthesizer interfaces designed to be used with a variety of personal computers, packaging the text-to-speech algorithm with its own dedicated processor greatly simplifies the integration of any system. By creating an intelligent peripheral device, we don't have to depend on operating systems and application programs to support speech synthesis.

The Microvox text-to-speech synthesizer is just such a smart peripheral device. It speaks any ASCII character string directed to it through either its serial or parallel input ports. The ASCII text can come from PRINT statements in a BASIC program or from a previously prepared disk file. Microvox connects to the computer in the same manner as a printer or modem, and virtually anything that can be printed or viewed on the terminal screen can be spoken.

The Microvox is controlled by the host computer through that same connection by means of special character sequences either transmitted before the text to be spoken or embedded in it. These control sequences are in the form:

*!letter,numeral*

The exclamation point is a signal to the Microvox that a control sequence follows. Operating modes and options can be changed at any time by sending the appropriate sequences. Table 2 lists some of the control sequences and their functions. I'll write about the intricacies of the Microvox text-to-speech algorithm and the control capabilities next month.

**SC-01A Phoneme Synthesizer**

As I mentioned before, the Microvox is a combination of two major

# Our "Personal" Improvement Plan

## MICROBYTE Add-Ons for the IBM Personal Computer from ASAP

MICROBYTE lets your IBM Personal Computer become all that it can be with a wide variety of enhancements. We can stretch memory, increase computing ability, provide printer support, improve storage capacity and expand the overall capability of your system to reach limits you never thought possible.

With MICROBYTE and ASAP your Personal Computer has all the potential you need for a variety of applications: video games, educational use, home budget applications or business use.

All MICROBYTE add-ons are constructed of high quality components and feature gold contacts and clear solder mask. Built to MICROBYTE's rigid standards, each board is fully assembled and tested.

Choose the IBM add-ons you need for your applications. Then call ASAP today, and start your own "Personal" improvement plan.

- Expansion Chassis with 5-slot motherboard
- 256K RAM Board
- Winchester Disk Drive and Controller, 6 and 12 megabytes (specify)
- Expansion Chassis with one or two 5 1/4" floppy disk drives, either 48 TPI or 96 TPI, single-sided or double-sided, double-density
- 32K Serial Printer Buffer Board
- 32K Parallel Printer Buffer Board
- EPROM Board up to 32K



ASAP offers a 15-day buyer protection policy: full money-back guarantee if not totally satisfied.

**Ordering information:** name, address, phone; ship by: UPS or Mail. Shipping charge: add \$2.90 up to 1 lb. (UPS blue), U.S. Mail add \$1.50 (U.S. only) (\$25.00 minimum order). **Terms:** We accept cash, check, money orders, Visa and Master Charge (U.S. funds only). Tax: 6% Calif. res. COO's and terms available on approval (School PO's Accepted).

Toll free outside California: (800) 421-7701 inside California: (213) 595-6431 (714) 891-2663

ASAP Computer Products LTD., 116 Viceroy Road., D-12 Concord, Toronto, Ontario, Canada L4K 1A9  
(416) 738-0500 (800) 268-1996

Circle 35 on Inquiry card.

**asap**  
computer  
products, inc.

1188 E. Willow St., Signal Hill, CA 90806

# COMPUVIEW'S CP/M-86 GIVES YOU WHAT IBM CAN'T

## Increased Productivity

Innovative features which dramatically increase productivity include built-in horizontal scrolling for up to 254 columns and screen line editing, which lets you extensively edit or re-enter any command line on the screen for CP/M-86 and application programs. Previously only available on mainframe computers, this greatly reduces the amount of re-typing necessary due to mis-typed or repeated commands. Long strings of commands can also be repeated with a few keystrokes. Its almost like having a built-in full screen editor for every program you use. And with 25% more disk capacity you will be swapping disks a lot less.

## We Don't Lock You In

We can read and write not only IBM CP/M-86 disks, but also IBM MSDOS and many other CP/M double density disks. And files may be transferred with other CP/M and CP/M-86 computers via the serial port. The screen driver with status line and horizontal scrolling faithfully emulates many popular terminals. Of course we're software compatible with IBM and have a superset of their features. And you may even find our manual to be better than IBM's.

## No Software Shortage

Most CBASIC programs will run perfectly with our CP/M-86 and CBASIC-86. Even most programs compiled with CBASIC 8080 will run with CBASIC-86. And Pascal-MT is available too. Remember, we emulate most CRT terminals.

## V-COM DISASSEMBLER Labels, ASCII, Exceptional Speed

No other Z80 CP/M disassembler produces understandable source code as quickly as V-COM. It is INTEL and ZILOG compatible, and features easy to read code with a cross reference table. Best of all, it can create source code with user defined labels, storage areas and ASCII strings. V-COM is exceptionally fast and can disassemble a typical 12K .COM file into a 76K .ASM file, containing 7500 lines of source code, and a 33K cross reference file in under two minutes with 8" SD floppies. (About five times faster than others).

The unique user created information files let you specify labels for 8 and 16 bit values and the location of storage areas, tables and ASCII strings. The disassembled code can be sent to the console, the disk and the printer, or any combination at once.

## Compare CompuView with IBM CP/M-86

Feature	Compuview	IBM
Horizontal Scrolling	Yes	No
Screen Line Editing	Yes	No
Page Control	Yes	No
Emulate Popular Terminals	Yes	No
'Smart' CRT Functions	Yes	No
Read/Write IBM MSDOS Disks	Yes	No
Serial File Transfer	Yes	No
Support Non-IBM Hardware	Yes	No
Menu Driven Configuration	Yes	No
Programmable Function Keys	Yes	Yes
Status Line	Yes	Yes
Serial and Parallel Printers	Yes	Yes
File Capacity	193K	154K

CP/M-86 for IBM PC ..... \$285  
 Quad Density Drive Version . \$350  
 Winchester Disk Version .... \$425  
 Manual Only ..... \$20

VEDIT-86 With Above  
 Purchase ..... \$125  
 This version of VEDIT has horizontal scrolling up to 254 columns

CBASIC-86 ..... \$325  
 PASCAL-MT-86 ..... \$600

## 782K for your IBM PC

Tandon quad density, double sided drive gives 782K file capacity. Fits into IBM PC as drive B or connect two externally as drives C and D. Requires CompuView CP/M-86. Easy to install. .... \$450  
 Complete external drive expansion with 1.5 Mbyte capacity. .... Call

Each package includes a 30 page manual, sample program files and variations of V-COM compatible with TDL, MAC and ZILOG assemblers. Feature for feature, no other disassembler at any price even comes close. .... \$80  
 Manual Only ..... \$12

## 8086 SOFTWARE

VEDIT full screen editor for CP/M-86, MSDOS, IBM Personal Computer and IBM Displaywriter ..... \$195

CP/M-86 BIOS for popular S-100 disk controllers and SCP 8086 computer. Source Code ..... \$90

Bootable CP/M-86 disks for popular S-100 computers .. Call



The newest generation VEDIT combines sophisticated program development editing with useful word processing features and new powerful 'TECO' like macros.

## User Oriented

Fast and easy editing for program development and word processing. Includes automatic screen scrolling, a status line with the cursor's line and column positions, an 'Undo' key, and recovery from full disk conditions (you can delete files or change disks). Fully adapts to your system with a menu driven customization for keyboard layout, CRT selection and more. Since VEDIT receives major enhancements twice a year, you're assured that VEDIT will always be 'state of the art' with our inexpensive update option and support you can really count on.

## Performance

Exceptional speed and true 'what you see is what you get' full screen editing with a convenient array of cursor movements and editing functions. Edits files up to one disk in length, and holds up to 45K of a file entirely in memory. You can insert a specified line range of another file anywhere in the text, and change disks in the middle of an edit session. Includes search and replace, text move and copy, complete file handling and flexible macros. Unique automatic indenting for use with structured languages such as Pascal, 'C' and PL/I. Other features for assembly language, Fortran and Cobol.

## Word Processing

Features include word wrap, adjustable left margin, reformatting of paragraphs, word and paragraph oriented cursor movement and deleting, and printing with imbedding of printer control characters. May be used stand-alone or in conjunction with most text output processors.

## Hardware Support

CRT version supports over 40 terminals, including ANSI standard and all screen sizes. Utilizes 'smart' terminal features for fast screen updating. Your keyboard layout can use any available function and cursor keys. Memory mapped version offers high speed, flexibility, supports bank select and the SSM VB3. Versions for Fulcrum VIO-X, PLICEON and TDL video boards.

## New Macros

Ten buffers can hold macro command strings. These may be executed, edited, saved and loaded from disk. Macros can perform complex editing operations. (For example, a macro could automatically perform a series of global search and replace on many files). The buffers may also hold text, allowing extensive text 'cut and paste', including portions from multiple files. New startup command file can also setup VEDIT parameters, initialize a terminal's programmable function keys and more.

## Ordering

Please specify your microcomputer, video board or the CRT terminal version, 8080, Z80 or 8086 code, and disk format.

VEDIT - Disk and Manual  
 For 8080 or Z80 .....\$150  
 For CP/M-86 or MSDOS .....\$195  
 Manual Only .....\$18

VISA and MASTERCARD

Dealers - You can now carry VEDIT and V-COM on consignment.

IBM • Apple II Softcard • TRS-80 II and I • SuperBrain  
 Zenith Z89 • HP-125 • Xerox 820 • Cromemco  
 NorthStar • DEC VT180 • Televideo • Altos  
 Vector • Micropolis • MP/M • CP/M-86 • MSDOS

1955 Pauline Blvd., Suite 200  
 Ann Arbor, Michigan 48103  
 (313) 996-1299

**CompuView**  
 PRODUCTS, INC.

**MAINFRAME FEATURES FOR MICROCOMPUTERS**

CP/M and MP/M are registered trademarks of Digital Research, Inc. Apple II is a registered trademark of Apple Computer, Inc. Softcard is a trademark of Microsoft. TRS-80 is a trademark of Tandy Corporation. IBM Personal Computer is a trademark of International Business Machines, Inc.

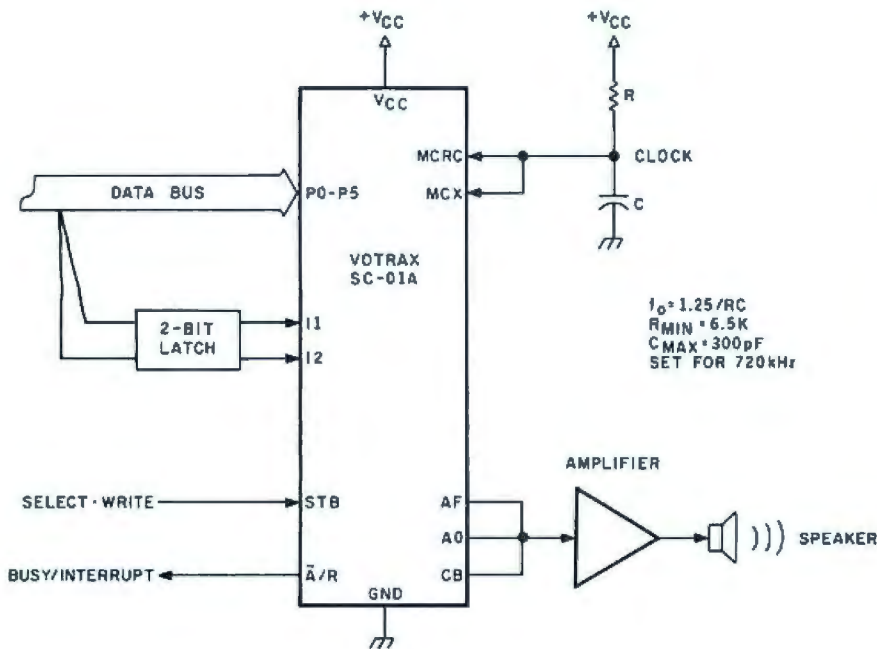

elements: a 6502-based control micro-computer and a Votrax SC-01A speech-synthesizer chip. I explained the SC-01A in detail in last September's Circuit Cellar article (reference 5), but for new readers I'll summarize the important facts.

The SC-01A is a 22-pin integrated circuit which consists of a digital code translator and an electronic model of the human vocal tract. The internal phoneme controller translates a 6-bit phoneme code and 2-bit pitch code into a matrix of spectral parameters that adjust the vocal-tract model to synthesize speech.

The SC-01A is manufactured using CMOS (complementary metal-oxide semiconductor) technology and operates within a range from +7 to +14 V. Handshaking with external control circuitry is accomplished through a strobe (STB) line and an acknowledge/request ( $\bar{A}/R$ ) line. A diagram of the generalized connection scheme appears as figure 1.

The output pitch of the SC-01A's voice is controlled by the frequency of the clock signal, which can either be supplied from an external source or set internally with a resistor/capacitor combination. The clock frequency is nominally 720 kHz, but subtle variations of pitch can be induced to add inflection by varying this frequency. Such variations prevent the synthesized voice from sounding too monotonous or artificial. Two separate pitch-control lines, I1 and I2, are available for gross variations in pitch so that the chip can seem to speak with more than one voice. These so-called manual-inflection controls operate independently of clock-rate-induced inflection.

The 64 SC-01A phonemes defined for the English language are listed in table 3 on page 72. Most of these correspond to speech sounds, but two produce silence and one causes speech synthesis to stop. The sound for each phoneme is generated when a 6-bit phoneme code is placed on the control-register input lines (P0 through P5) and latched by pulsing the strobe (STB) input. Each phoneme is internally timed and has a duration ranging from 47 to 250 ms (milliseconds) depending on the phoneme selected

Figure 1: The general scheme to be followed in connecting the Votrax SC-01A to a microcomputer system.

# PHONE 1 FILLS THE VOID IN DATA COMMUNICATION

Powerful Z-80® communications software tools are now available. Fill the void between your microcomputer and mainframe.

Z-80 is a registered trademark of Zilog.

**PHONE 1**  
1011 River Lane • Loves Park, Illinois 61111 • 815/877-9008



# 212 for \$695.\*

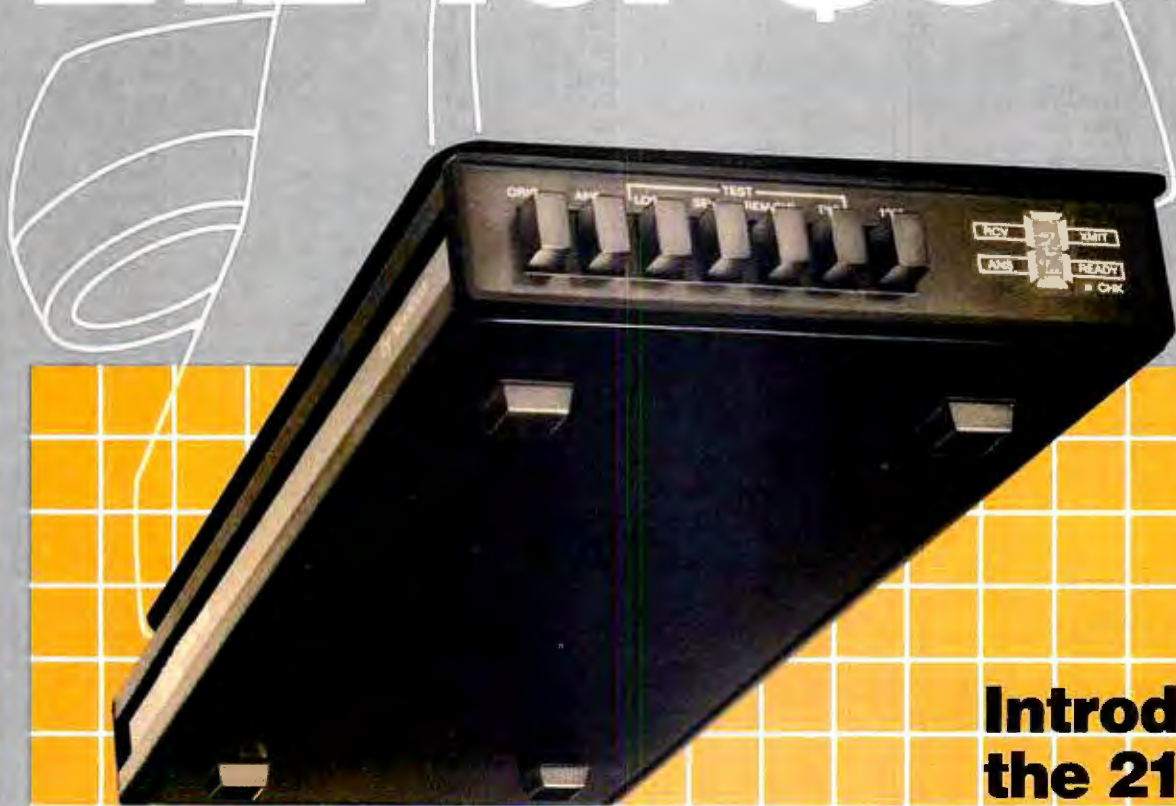

## Introducing the 212 Auto-Cat by

300 BAUD is fine for the basics.

But now you can get in the fast lane without getting expensive.

Our engineers have come up with a pair of custom microprocessors, five LSI circuits and a small miracle: the 212 Auto-Cat modem.

And if you've looked around, you know the \$695 price is part of the miracle.

Four times the speed. Half the size. All of the right auto-dial/answer functions.

Your dealer has them right now. No need to waste any more time. See him.



the recognized leader in  
personal communications

\*Suggested retail price

Circle 349 on inquiry card.

18664 Oxnard Street, Tarzana, California 91356 • Telephone: (800) 423-5419 and (213) 996-5060

**INCOME TAX ACCOUNTING**

# Quick Tax

has the finest software I've ever seen for the **Accounting and Tax Professional.**

The programs are so well designed and supported, we had no start-up problems."—Ronald Braun, C.P.A.

■ **1040 TAX PROGRAM** \$995

**ALL MAJOR FORMS & SCHEDULES**

**PRINTS ON IRS FORMS, OVERLAYS OR MULTI-PART FORMS**

**INDIVIDUAL OR BATCH PROCESSING**

**CAN PROCESS THOUSANDS OF RETURNS PER SEASON**

**RECURRING PRIOR YEAR INFORMATION AUTOMATICALLY UPDATED**

**DIAGNOSTIC REPORTS**

**LETTER OF INSTRUCTION**

**CLIENT BILLING**

**MAILING LIST/LABELS & ENVELOPES**

**UNLIMITED SUPPORTING SCHEDULES**

PLUS:

PROFORMA/TAX ORGANIZER

MULTI-STATE INTERFACE

TAX PLANNING

ALSO AVAILABLE:

GENERAL LEDGER/CLIENT WRITE-UP

AFTER THE FACT PAYROLL

AMORTIZATION & DEPRECIATION

SCHEDULES

ALL QUICK TAX PROGRAMS COME WITH

ONE YEAR WARRANTY & SUPPORT.

DEALER DISCOUNTS AVAILABLE.

See your nearest computer dealer. Or, call or write for more information.

Quick-Tax Software is available for Xerox 820, Radio Shack, IBM, DEC, Vector Graphic, Dynabyte and other CP/M based computers.

CP/M is a registered trademark of Digital Research, Inc.



319 Clawson St.  
S.I., N.Y.C., N.Y. 10306  
Dept. BM (212) 351-6143

Hexadecimal Phoneme Code	Phoneme Symbol	ASCII Character	Duration (ms)	Example Word
00	EH3	@	59	jacket
01	EH2	A	71	enlist
02	EH1	B	121	heavy
03	PA0	C	47	no sound
04	DT	D	47	butter
05	A2	E	71	make
06	A1	F	103	pail
07	ZH	G	90	pleasure
08	AH2	H	71	honest
09	I3	I	55	inhibit
0A	I2	J	80	inhibit
0B	I1	K	121	inhibit
0C	M	L	103	mat
0D	N	M	80	sun
0E	B	N	71	bag
0F	V	O	71	van
10	CH	P	71	chip
11	SH	Q	121	shop
12	Z	R	71	zoo
13	AW1	S	146	lawful
14	NG	T	121	thing
15	AH1	U	146	father
16	OO1	V	103	looking
17	OO	W	185	book
18	L	X	103	land
19	K	Y	80	trick
1A	J	Z	47	judge
1B	H	[	71	hello
1C	G	\	71	get
1D	F	]	103	fast
1E	D	-	55	paid
1F	S	-	90	pass
20	A	(space)	185	tame
21	AY	!	65	jade
22	Y1	"	80	yard
23	UH3	#	47	mission
24	AH	\$	250	mop
25	P	%	103	past
26	O	&	185	cold
27	I	'	185	pin
28	U	(	185	move
29	Y	)	103	any
2A	T	*	71	tap
2B	R	+	90	red
2C	E	.	185	meet
2D	W	-	80	win
2E	AE	.	185	dad
2F	AE1	/	103	after
30	AW2	0	90	salty
31	UH2	1	71	about
32	UH1	2	103	uncle
33	UH	3	185	cup
34	O2	4	80	bold
35	O1	5	121	aboard
36	IU	6	59	you
37	U1	7	90	June
38	THV	8	80	the
39	TH	9	71	thin
3A	ER	:	146	bird
3B	EH	:	185	ready
3C	E1	<	121	be
3D	AW	=	250	call
3E	PA1	>	185	no sound
3F	STOP	?	47	no sound

Note: T must precede CH to produce "CH" sound.  
D must precede J to produce "J" sound.

**Table 3:** The 64 SC-01A phonemes defined for the English language. Most of these correspond to speech sounds; two produce silence, and one causes speech synthesis to stop.

# IT'S CRISP. IT'S CLEAR. IT'S COMPATIBLE.



## Amdek's Video-300 green phosphor monitor is the easy-reading choice for almost any system — including IBM and Apple.

Everything about our 12" Video-300 monitor was designed to be easy. Easy to read. Easy to use. And easy to match up with practically any computer or word processing system, including the popular Apple and IBM personal computers. So it's easy to see why you should choose Video-300 for your text display needs.

### Amdek's Video-300 monitor features:

- Non-glare screen to eliminate distracting reflections
- P-31 green phosphor display for no-strain viewing
- 80 x 24 character display
- 18MHz band width 900 lines (center) resolution
- Built-in carrying handle for portability
- Light-weight, industrial-grade cabinetry (only 17 lbs.)
- UL, FCC approved
- Full one-year warranty covering parts and labor

So ask your dealer about Video-300 — part of Amdek's complete line of color, green phosphor and black and white monitors. Then match Video-300's performance and price against any other display monitor. For quality and value, you'll choose Amdek.

# AMDEK

Amdek Corporation, 2420 E. Oakton St., Suite E, Arlington Heights, IL 60005. (312) 364-1180 • TLX: 25-4786

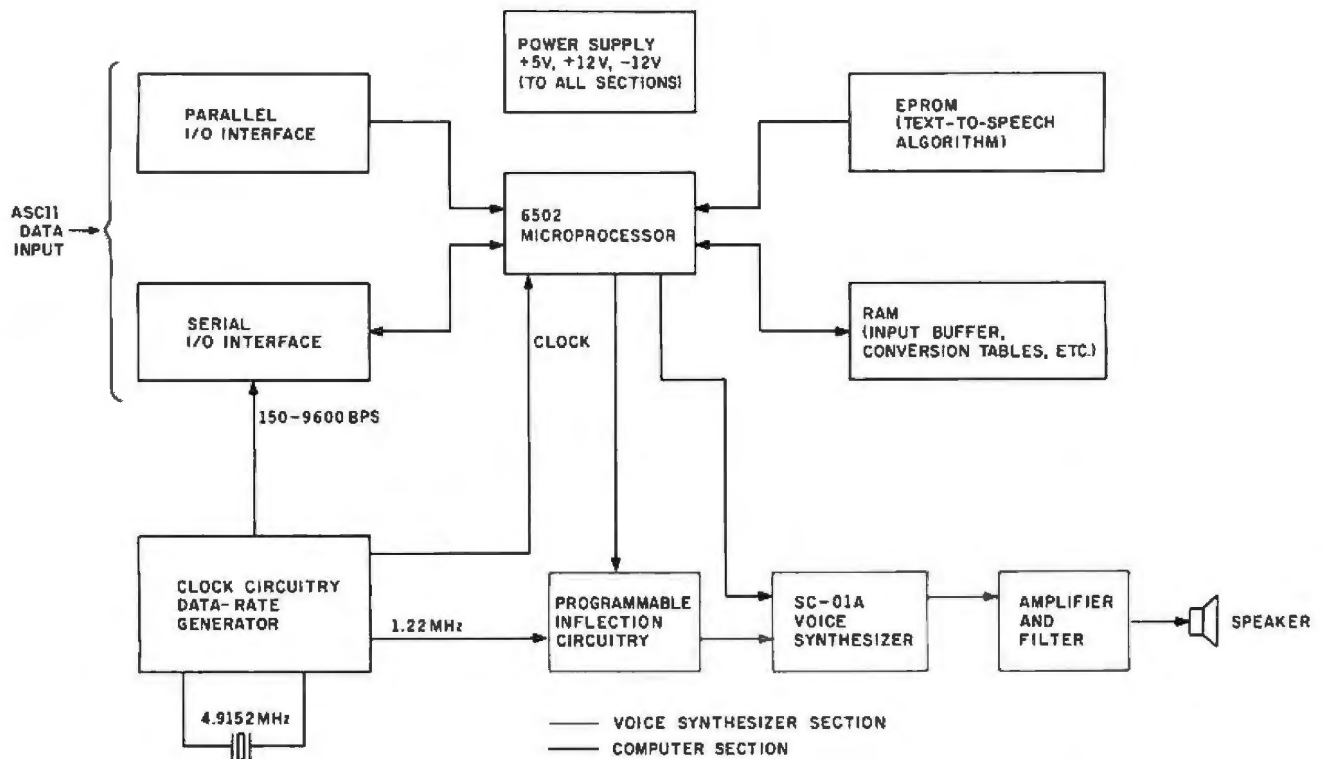

**Figure 2:** Block diagram of Microvox. The Microvox hardware can be viewed as a general-purpose 6502-based computer with a speech synthesizer attached using a memory-mapped I/O (input/output) port.

The computer section (shown in black) uses 14 integrated circuits for serial and parallel I/O, address decoding, memory, and other processing functions. Five additional chips (outlined in red) constitute the phoneme synthesizer, inflection circuitry, and audio amplifier.

and the clock frequency. The  $\overline{A/R}$  line goes from a logic 1 to a logic 0 while a phoneme is sounding.

The usual method for using the SC-01A with a microprocessor sets up the hardware so that the computer system directly times the transmission of phoneme codes. This method sends phoneme codes to the synthesizer chip through a latched parallel output port and monitors the synthesizer's activities through the  $\overline{A/R}$  line, which is connected to an input port or interrupt line.

### Microvox Hardware Overview

Figure 2 is a basic block diagram of Microvox. As previously mentioned, the Microvox contains its own micro-computer that allows the unit to be configured to function as an intelligent peripheral device; therefore, the Microvox hardware can be viewed as a general-purpose 6502-based computer with a speech synthesizer attached using a memory-mapped I/O (input/output) port.

The computer section uses 14 inte-

grated circuits for serial and parallel I/O, address decoding, memory, and other processing functions. Five additional chips constitute the phoneme synthesizer, inflection circuitry, and audio amplifier (outlined in red).

## Variations in pitch prevent the synthesized voice from sounding too monotonous or artificial.

The Microvox is best explained by dividing the circuitry into four functional subsections: processor and timing, memory, serial and parallel I/O, and speech synthesizer. A complete schematic diagram of Microvox appears as figure 3a on pages 76 and 77 and figure 3b on pages 78 and 79.

### Processor and Data-Rate Clock

The 1-MHz (megahertz) 6502

microprocessor, the same type used in the Apple II and Atari 800 computers, and the data-rate generator (shown by itself in figure 4 on page 80) obtain their clock signals from a circuit that divides down a 4.9152-MHz frequency from a crystal-controlled oscillator. You may find the rationale for using this low-cost clock divider interesting.

Most data-rate-generator circuits are very costly because they use specialized data-rate generator chips such as the COM5016, which you must have if you really need to cover 134.5 and 110 bps (bits per second) as well as the other standard data rates from 75 to 19,200 bps. The former two data rates are the only ones that require oddball frequencies. If you can get along without them (and most people can nowadays), no special divider networks or integrated circuits are required. By using a 4.9152-MHz ( $75 \times 2^{10}$ ) base frequency and a 12-stage binary divider (a CD4040, IC6 in figure 4), the nine remaining rates are derived directly.

# One of the great masters?

Although the Datasouth DS180 matrix printer may not exactly rate as a work of art, our customers have a *very* high opinion of its value. Over the past year, we have shipped thousands of DS180 printers to customers throughout the world. Many of our sales now come in the form of repeat business—a strong testimonial to the acceptance of a product.

The success of the DS180 in a very competitive market did not happen by accident; rather through our sensitivity to the needs of the industry. This sensitivity we carry through research and development, production and quality control and finally to after sales support and service.

Recently we introduced new enhancements to make the DS180 printer even more versatile. Dot addressable raster scan graphics produces output of computer generated charts, maps and graphs at a resolution of 75 x 72 dots per inch. Variable horizontal pitch selection allows printing at 10, 12 or 16.5 characters per inch plus double wide printing at 5, 6 or 8.25 characters per inch. The expanded 2K FIFO print buffer handles a full CRT screen dump at up to 9600 baud without delaying the host system. We also offer transparent mode for isolating communications problems, and for APL users, the dual ASCII/APL character set option.

Check our list of features and we think you will agree that the DS180 offers the most complete performance package in matrix printers.

#### DS180 PRINTER STANDARD FEATURES

- Microprocessor Control
- 180 CPS Print Speed
- Bidirectional/Logic Seeking
- 1000 Character Buffer (Expandable)
- 9x7 Dot Matrix
- Expanded Characters
- Adjustable Printhead 1-6 Copies
- 96 ASCII Character Set
- Cartridge Ribbon
- 132 Column Print Width
- Tractor Feed (Front or Bottom)
- Non Volatile Format Retention
- Top of Form
- Horizontal Tabs
- Vertical Tabs
- Perforation Skip Over
- Auto Line Feed
- 6/8 LPI
- Auto End of Line Carriage Return
- 5 IPS Paper Slow
- Parallel and Serial Interfaces
- 110 9600 Baud Communications
- Terminal Status Indicators
- Audio Alarm
- Self Test
- X on, X off
- Paper Out Detection

#### OPTIONAL FEATURES

- Compressed Print—10, 12, 16.5 cpi
- High Resolution Dot—Addressable Graphics
- 2k Expanded Print Buffer
- APL/ASCII Character Set



The DS180 is available nationwide through our network of sales/service distributors.



Now Available Nationwide  
Through Participating  
COMPUTERLAND Stores

Circle 149 on inquiry card.

**datasouth**  
**computer corporation**

P.O. Box 240947 • Charlotte, NC 28224 • 704/523-8500

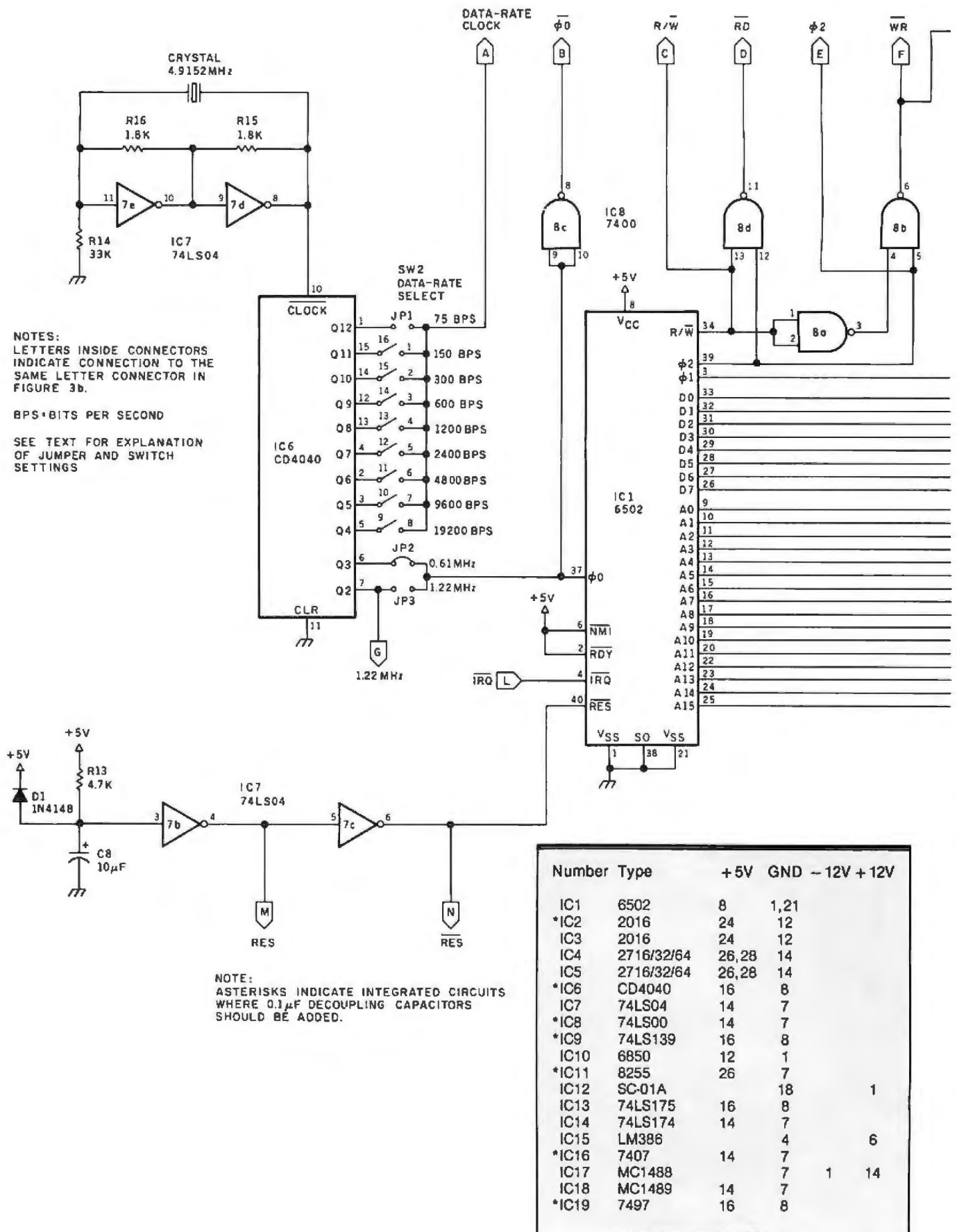
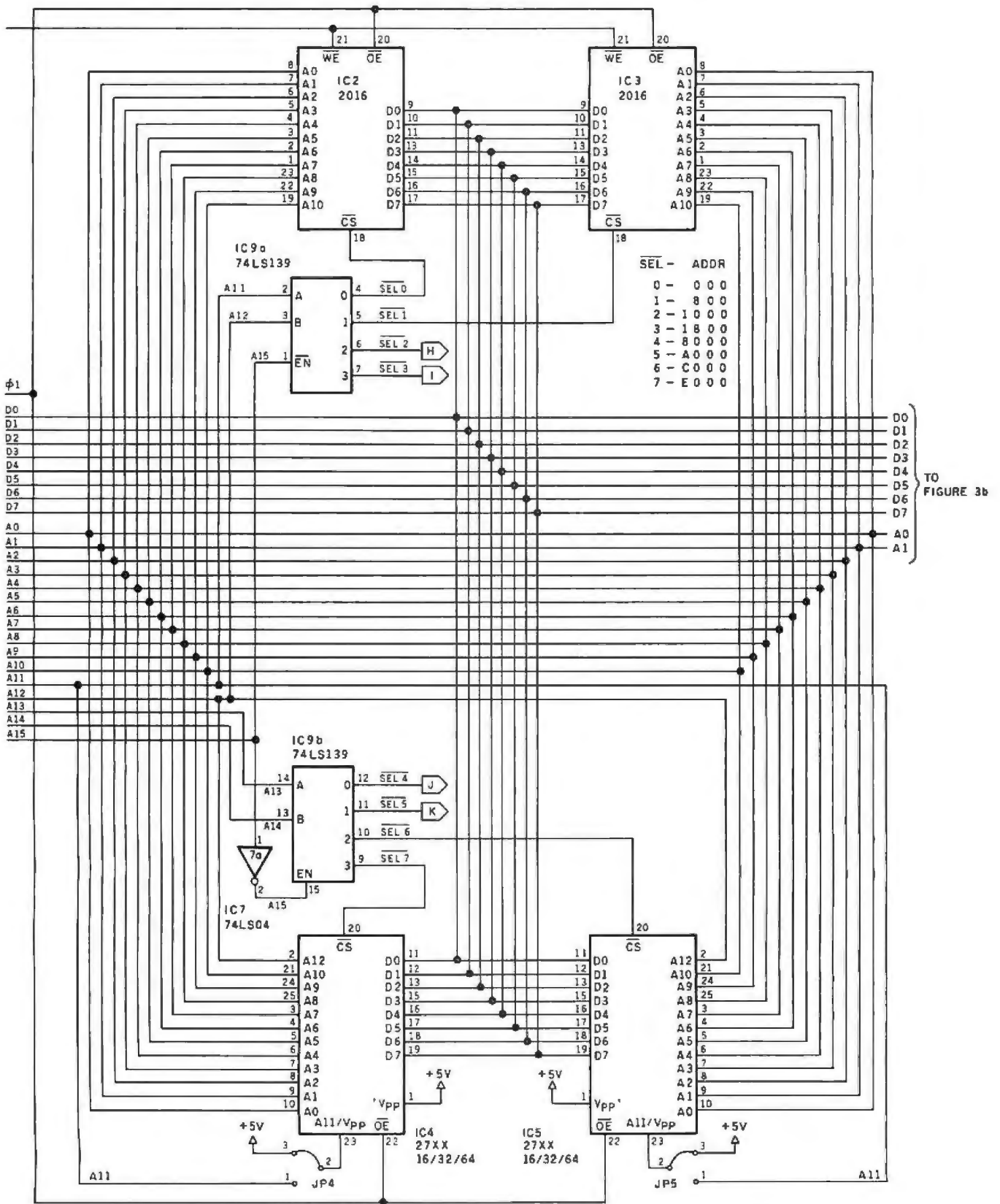

Figure 3a: A section of the Microvox schematic diagram. Shown here are the 6502 microprocessor and the timing section. The schematic is continued in figure 3b on the next two pages.



\* 2764 ONLY

NOTE:  
LETTERS INSIDE CONNECTORS  
INDICATE CONNECTION TO  
THE SAME LETTER CONNECTOR  
IN FIGURE 3a.

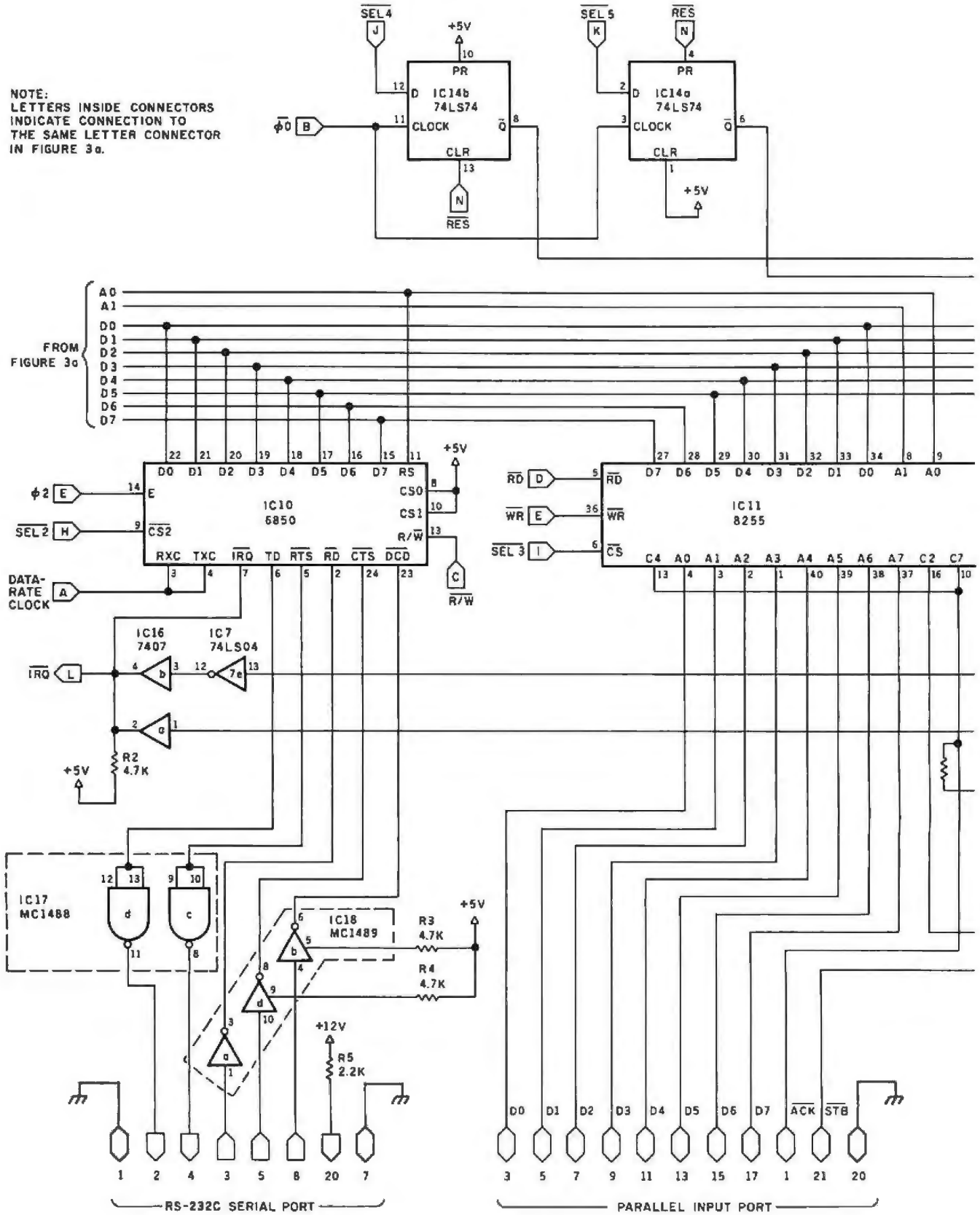
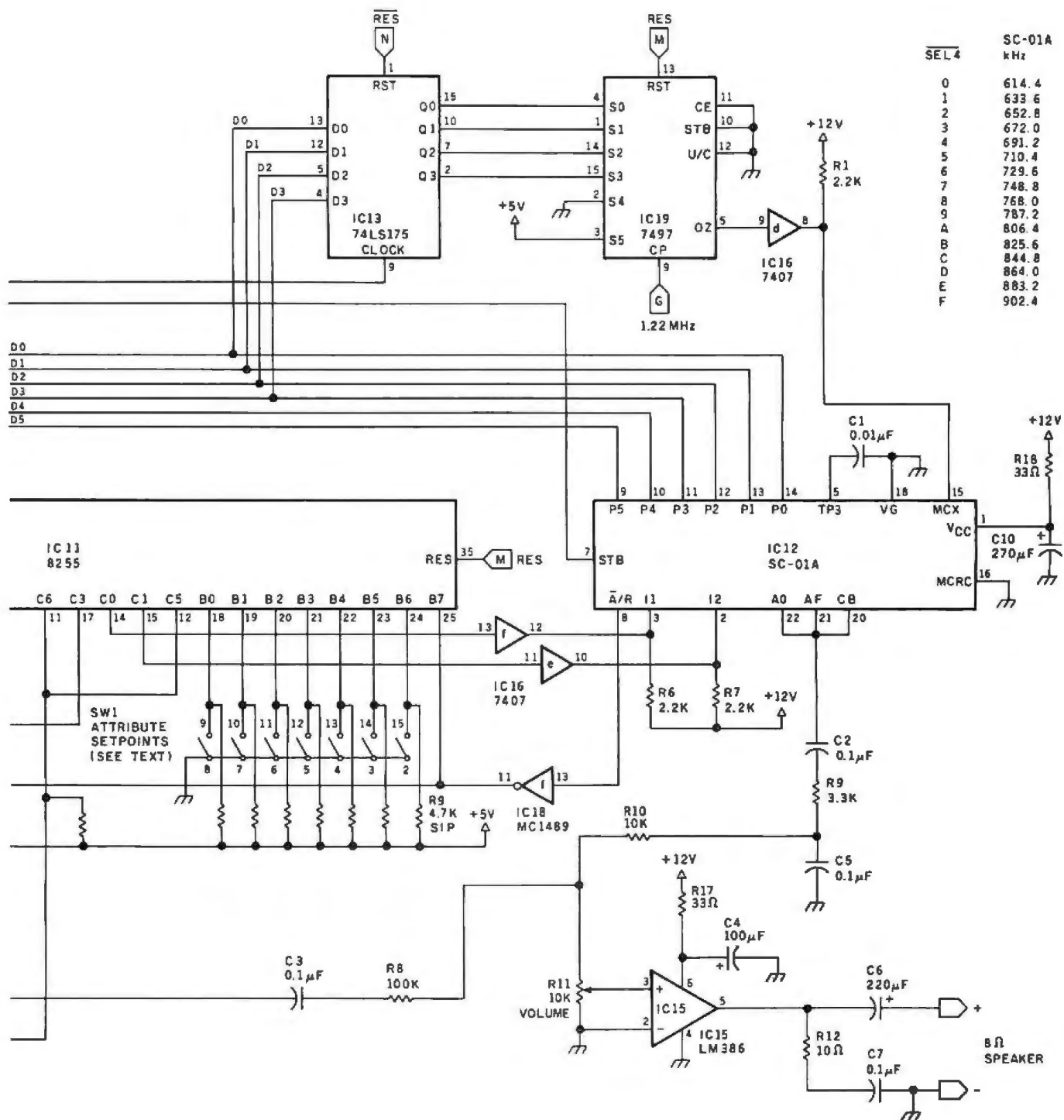

Figure 3b: A section of the Microvox schematic diagram, featuring the serial and parallel I/O and the SC-01A speech-synthesis integrated circuit.





This approach does require one other design compromise. The 6502 processor is specified to operate at 1 MHz, but, using this crystal and divider circuit, only 611 kHz and 1.22 MHz are available as system-clock signals. The computer must run at either 61 percent or 122 percent of its rated speed.

Practically speaking, this is not a

problem. The 1-MHz specification is for worst-case conditions, which you probably will not have. I have personally run 1-MHz 6502s at 1.8 MHz with no trouble. Furthermore, in the Microvox application, we can note that the speech synthesizer requires data at only about 200 bps to speak continuously. Processor speed is just not significant except when receiving

and manipulating data at 19,200 bps. Just to be on the conservative side, while the hardware can produce rates from 75 to 19,200 bps, I have specified rates of 150 to 9600 bps for the Microvox.

### Memory Section

The address-decoding and memory section of the Microvox consists of

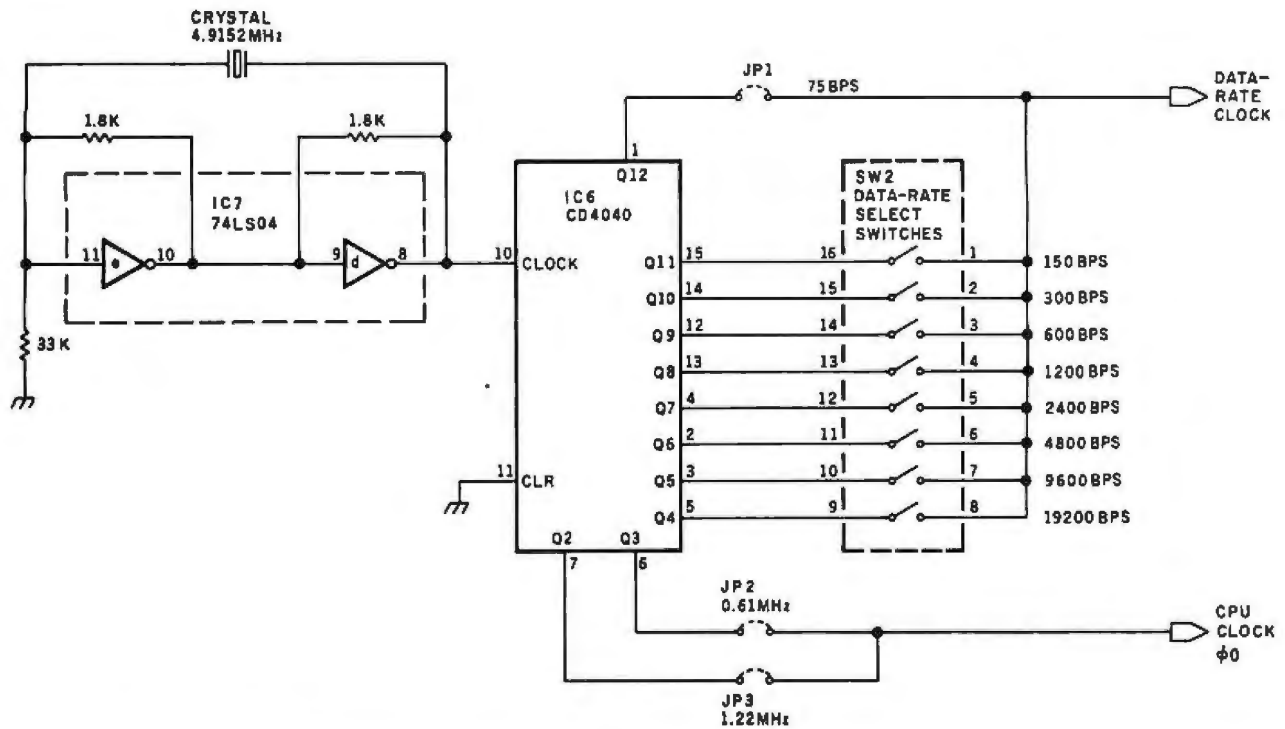

Figure 4: A detail from the Microvox circuit, showing the circuitry that derives the data-rate and clock frequencies. With this simple, low-cost arrangement, all standard data rates, except 110 bps (bits per second) and 134.5 bps, are available. Also, a trade-off must be made in selecting a clock rate for operating the microprocessor.

Name	Hexadecimal Address	Connection and Function
$\overline{\text{SEL0}}$	000	IC2 memory block (RAM)
$\overline{\text{SEL1}}$	800	IC3 memory block (RAM)
$\overline{\text{SEL2}}$	1000	IC10 serial port
$\overline{\text{SEL3}}$	1800	IC11 parallel ports
$\overline{\text{SEL4}}$	8000	IC14 inflection clock rate
$\overline{\text{SEL5}}$	A000	IC14 phoneme latch
$\overline{\text{SEL6}}$	C000	IC5 memory block (EPROM)
$\overline{\text{SEL7}}$	E000	IC4 memory block (EPROM)

Table 4: The 5 high-order bits on the 6502 address bus are decoded by IC9 to provide 8 strobe signals that control various parts of the system.

IC2 through IC5 and IC9. IC9 (a 74LS139) decodes the 5 high-order bits on the address bus to provide 8 strobe signals, as listed in table 4.

In the Microvox configuration, memory components IC2 and IC3 are intended to be RAM, while IC4 and IC5 are meant to be ROM or EPROM (erasable programmable read-only memory). The pin designations for IC2 and IC3 are for 2K-by-8-bit RAM chips, such as the Hitachi 6116 or

Toshiba 2016. These components are pin-compatible with the type-2716 EPROM, so you could use 2716s in these sockets instead, if the computer were being used in some other application.

The read/write memory (IC2 and IC3) is used for conversion tables and register stacks and as the ASCII input buffer. A buffer is required because the Microvox can receive data faster than it can speak it. The standard

Microvox uses only one RAM chip (installed as IC2), which provides a 1K-byte input buffer; by adding the second RAM chip in IC3, this can be optionally expanded to 3K bytes of text memory (for long-winded speeches).

The text-to-speech conversion routine for the standard Microvox is stored in 8K bytes, presently consisting of two type-2732 EPROMs inserted in the sockets for IC4 and IC5. As production increases or EPROM prices drop, a single 8K-byte 2764 EPROM (or its ROM equivalent) will be used. Any of the compatible type-2716 (2K-by-8-bit), type-2732 (4K-by-8-bit), or type-2764 (8K-by-8-bit) EPROMs can be used in these IC positions, depending upon the jumper selections JP4 and JP5.

### Serial and Parallel I/O

Microvox, unlike most other voice synthesizers, has both serial and parallel input ports to receive ASCII characters. The serial port uses a Motorola MC6850 ACIA (asynchronous communications interface adapter, IC10). During system initialization, the ACIA's functional

# SOLUTIONS™ are free and easy with the ASSOCIATE™



The ASSOCIATE is a field proven desktop microcomputer with many features: 64K memory plus 2K PROM; 720K bytes of floppy disk storage; Z80A 4Mhz processor; DMA disk controller, interrupt controller and timer; unique anti glare screen; typewriter style keyboard, numeric keypad and 10 function keys; and 2 RS232C ports. Optional parallel, IEEE 488, and RS449 ports give added flexibility. The remote or integrated hard disk option offers you needed growth capability.

Your SOLUTIONS are supplied FREE. The CP/M operating system provides access to thousands of software programs. We start you out with FREE wordprocessing by Spellbinder, FREE business planning by Microplan, FREE accounting and FREE testing programs; an excellent combination for a total business system. To make it easy to use we have programmed the 29 programmable keys and added a quickly readable keyboard template for each SOLUTION. Other SOLUTIONS and templates are available such as dBASE II, MBASIC, SuperCalc, WordStar and more. You may even program the keys and design a template to match your own chosen software.

You may select FRIENDS to assist your ASSOCIATE such as printers from Qume, Ricoh and NEC. Ribbons, printwheels, and disks are also available at low cost. With nationwide service and repair from General Electric you have a total package which is hard to beat. And the price; well, it's an unbeatable **\$3,450**. Don't wait! Contact us today for a dealer near you and bring SOLUTIONS to your business or personal computing needs. Data Technology Industries, 701A Whitney Street, San Leandro, CA 94577 (415) 638-1206, TWX 910-366-2072.

Data Technology Industries™



SOLUTIONS, ASSOCIATE and FRIENDS are Trademarks of Data Technology Industries; Spellbinder is a Trademark of LEXISOFT, Inc.; Microplan is a Trademark of Chang Labs; CP/M is a Trademark of Digital Research; WordStar is a Trademark of MicroPro; SuperCalc is a Trademark of SORCIM; dBASE II is a Trademark of Ashton-Tate; MBASIC is a Trademark of Microsoft.

# board the bus

## INDUSTRIAL QUALITY BOARDS FOR THE IEEE-696/S-100 BUS

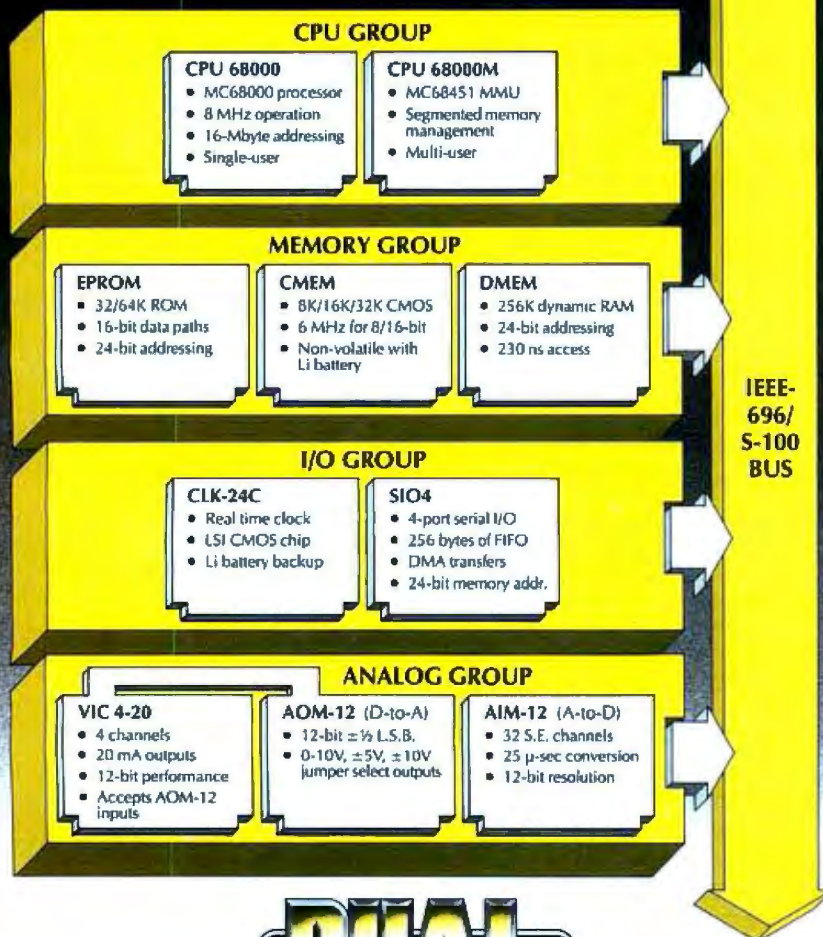
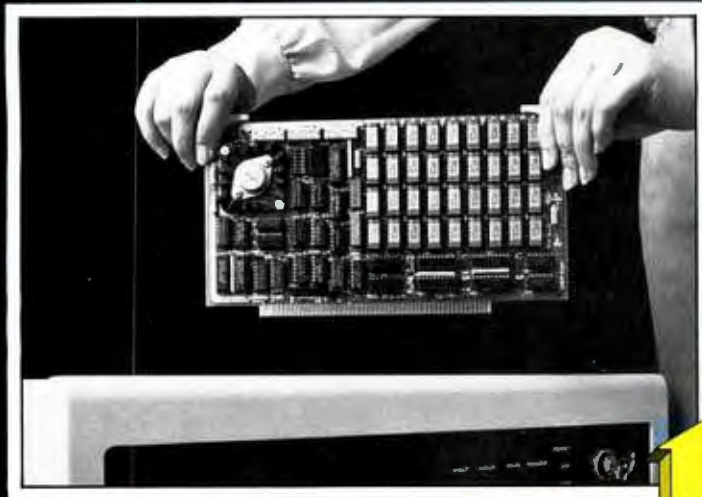

system reliability/system integrity

Sales representatives in most metropolitan areas.

OEM and Dealer pricing is available.

2530 San Pablo Avenue • Berkeley • CA 94702 • (415) 549-3854 • 172029 SPX

configuration is set up; communication parameters such as character word length, clock division ratios, parity, and stop bits are selected by setting the proper bits in the ACIA's control register. The data rate is set by the system data-rate clock (from SW2 and IC6), and data is sent and received from the transmit- and receive-data registers, respectively. Framing errors, parity errors, buffer status, and handshaking status are determined by reading the ACIA's status register.

On the Microvox, the serial port can be used with or without hardware handshaking, that is, with or without using the RS-232C Clear to Send, Data Carrier Detect, Ready to Send, and other lines. The Microvox software incorporates software handshaking, which is especially useful when communicating over a modem link or with terminals that do not use handshaking signals.

When receiving ASCII text in the software-handshaking mode, the Microvox sends an "@" (at sign) to the host computer when its input buffer is almost full, signaling the host to stop sending data. The Microvox sends a "#" (number sign) when it is ready to receive data again. (The characters used for signaling can be changed to the X-on and X-off control characters if need be.)

Obviously, this handshaking is not needed if the data comes from the host at a speed slower than the rate at which the buffer is emptied. The parallel-input section uses a programmable Intel 8255 PIA (peripheral interface adapter, IC11). As configured, 8 bits of the PIA are used to receive ASCII data in parallel format. By using two additional connections for data-available-strobe and acknowledge signals, the Microvox can be made to work with a Centronics-compatible parallel printer interface.

Also attached to the PIA is the DIP (dual-inline pin) switch SW1, which can be used to select operating parameters as follows. Bit 0 selects hardware or software handshaking; bit 1 selects receipt of the ASCII input data through the serial or parallel port; bits 2 through 4 set the serial-

# VISUAL presents ergonomic elegance and high performance in a low-cost terminal.

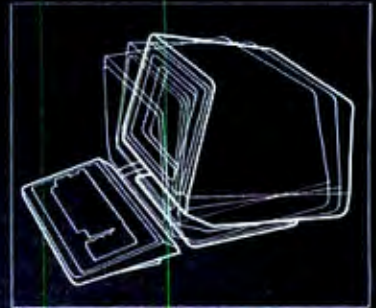

Tilt: 10° forward, 15° backward



Swivel: 270°

**\$695 list**

The VISUAL 50 represents a new approach in low cost terminals. Although it costs drastically less, it offers the features you expect from the high priced units.

For example, the VISUAL 50 enclosure is ergonomically designed in light weight plastic and can easily be swiveled and tilted for maximum operator comfort. A detached keyboard, smooth scroll, large 7 x 9 dot matrix characters and non-glare screen are a few of the many human engineering features normally offered only on much higher priced terminals.

Another distinctive feature of the VISUAL 50 is its emulation capability. VISUAL 50 is code-for-code compatible with the Hazeltine Esprit,<sup>™</sup> ADDS Viewpoint,<sup>™</sup> Lear Siegler ADM-3A<sup>™</sup> and DEC VT-52.<sup>\*</sup> Menu driven set-up modes in non-volatile memory allow easy selection of terminal parameters.

And you're not limited to mere emulation. As the chart shows, the VISUAL 50 has features and versatility the older, less powerful low cost terminals simply cannot match.

The price of the VISUAL 50? Only \$695 list. Call or write for full details on the latest in the industry's finest line of video terminals.

Service available in principal cities through Sorbus Service, Division of Management Assistance, Inc.

**VISUAL**

See for yourself

Visual Technology Incorporated  
540 Main Street, Tewksbury, MA 01876  
Telephone (617) 851-5000. Telex 951-539

## FEATURE COMPARISON CHART

FEATURE	VISUAL 50	Hazeltine Esprit	ADDS Viewpoint	Lear Siegler ADM-5	Televideo 910
Tilt and Swivel	YES	NO	NO	NO	NO
Detached Keyboard	YES	NO	YES	NO	NO
N-Key Rollover	YES	NO	YES	NO	NO
Audible Key Click	YES	YES	NO	NO	NO
Menu Set-Up Mode	YES	NO	NO	NO	NO
Status Line	YES	NO	NO	NO	NO
Full 5 Attribute Selection	YES	NO	NO	NO	YES
Smooth Scroll	YES	NO	NO	NO	NO
Line Drawing Character Set	YES	NO	NO	NO	NO
Block Mode	YES	YES	NO	NO	YES
Insert/Delete Line	YES	YES	NO	NO	YES
Bi-Directional Aux Port	YES	YES	NO	YES	NO
Columnar Tabbing	YES	YES	NO	NO	YES
Independent RCV/TX Rates	YES	NO	NO	NO	NO
Answerback User Programmable	YES	NO	NO	OPT	NO

Circle 502 on Inquiry card.

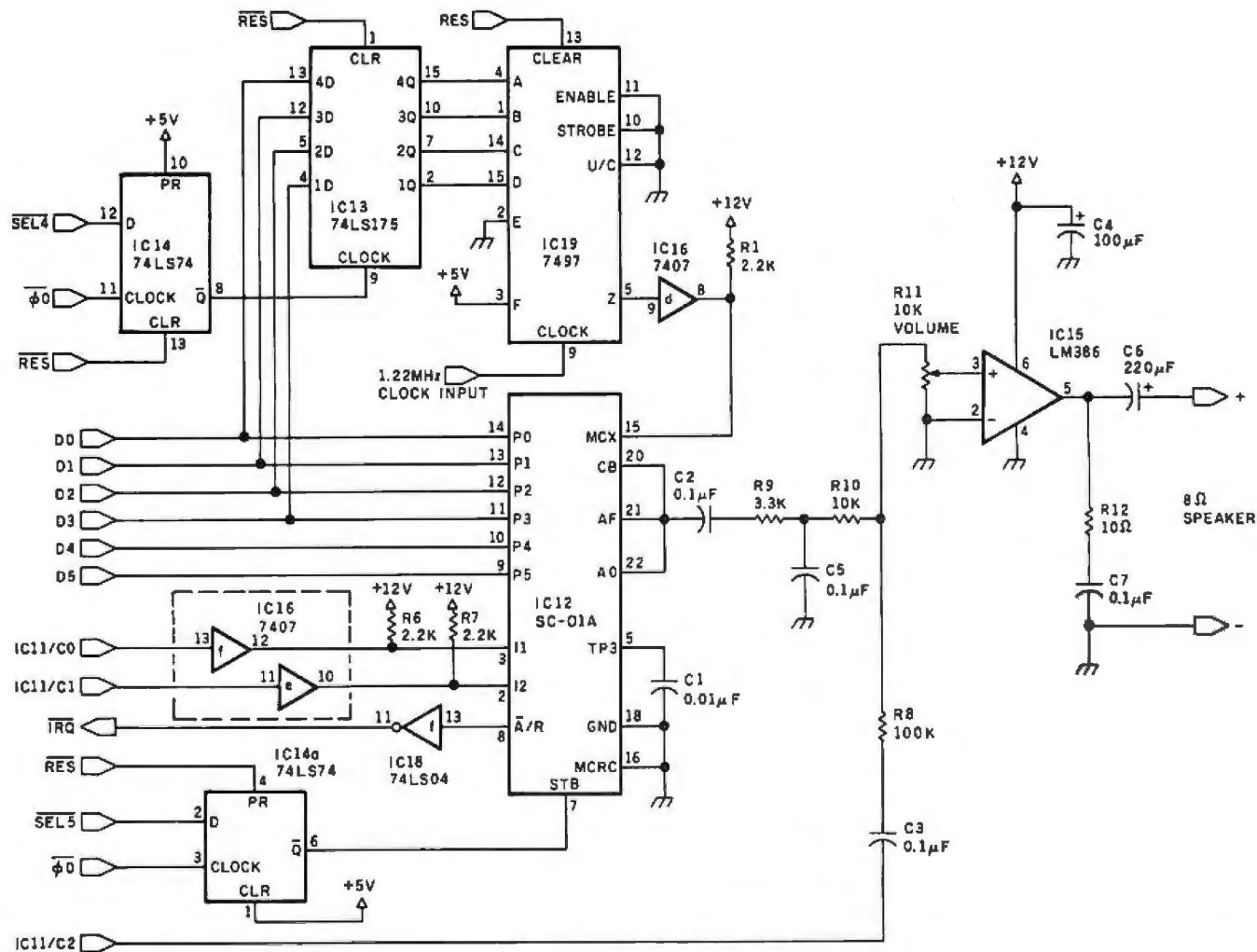

Figure 5: The business end of the Microvox, the circuitry that actually produces the artificial voice. This design is similar to the Sweet Talker speech synthesizer; it is based also on the Votrax SC-01A integrated circuit. The main improvement is provision for 64 levels of pitch inflection, instead of the 4 levels available on the Sweet Talker.

input word length, stop bits, and parity on the ACIA; and bits 5 through 7 are not used.

### Speech Inflection

The business end of the Microvox, the circuitry that actually produces the artificial voice, is shown in the schematic diagram of figure 5. Regular followers of Circuit Cellar projects will recognize the Votrax SC-01A integrated circuit and notice that this design is similar to the Sweet Talker speech synthesizer from last September's article. This time, however, I have provided for 64 levels of pitch inflection, instead of the 4 levels previously available.

The output pitch of the phonemes is fundamentally controlled by the frequency of the clock signal provided to the SC-01A. In general use,

this frequency, set with a resistor/capacitor combination, is nominally 720 kHz. But as with any current-controlled analog circuit, the frequency may be susceptible to change from temperature variation and pickup of external noise.

### Coarse variations in pitch are best used for simulating completely different speaking voices.

In the Microvox, the analog clock circuitry is eliminated. Instead of using the SC-01A's internal timing circuit, the chip is configured for input of an external clock signal, derived

from the crystal-controlled system clock.

While the fundamental range of the output pitch is a function of the clock frequency, the two pitch-control lines I1 and I2 (the "manual-inflection" lines) can act independently to cause four coarse variations in pitch from the fundamental setting. I think that these coarse variations are best used for simulating completely different speaking voices rather than for vocal inflections. The frequency shift is simply too great.

The preferred way to influence the output pitch is by changing the external clock frequency fed into the SC-01A, although this takes more work. Subtle variations in output pitch can be obtained with reasonable effort, by shifting the clock frequency up or down by 20 or 40 kHz. And by apply-

# 64K STATIC RAM MEMORY

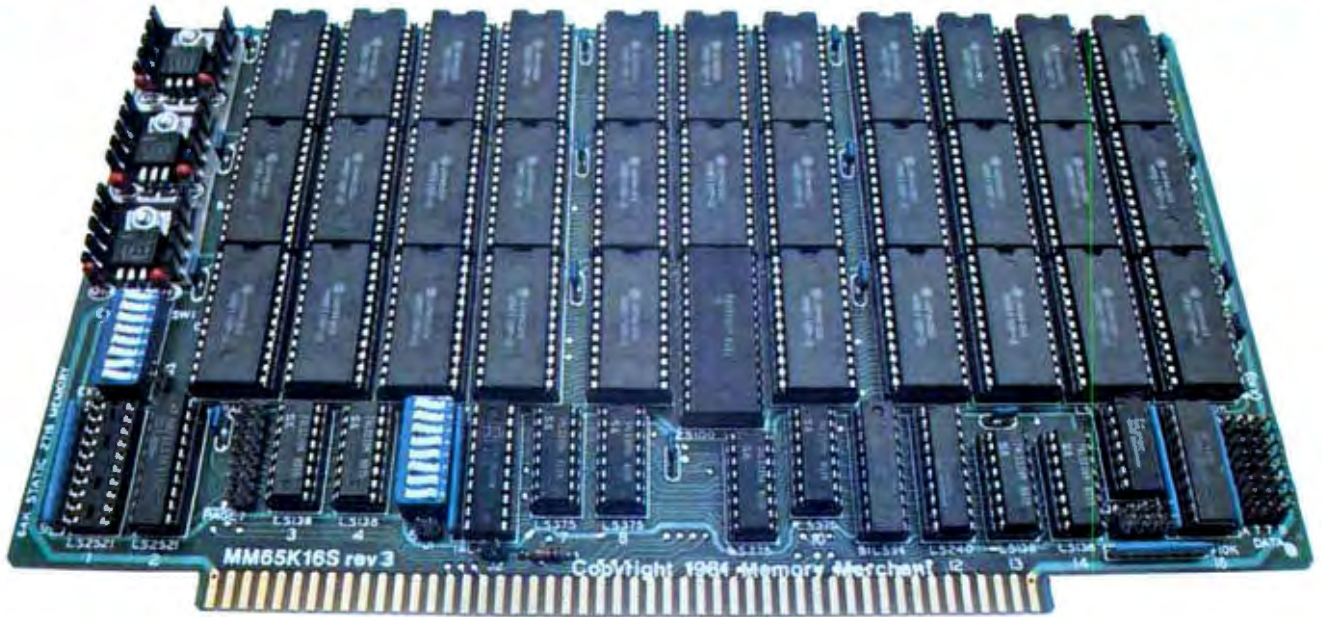

## S-100 STATIC MEMORY BREAKTHROUGH

Finally, you can buy state-of-the-art S-100/IEEE 696 static memory for your computer at an unprecedented savings.

Memory Merchant's memory boards provide the advanced features, quality and reliability you need for the kind of operational performance demanded by new high-speed processors.

### Completely Assembled.

These memory boards are not kits, nor skeletons — but top-quality, high-performance memories that are shipped to you completely assembled, burned-in, socketed, tested and insured with one of the industry's best warranties.

### Superior Design & Quality.

Memory Merchant's boards are created by a designer, well known for his proven ability in advanced, cost-efficient memory design. Innovative circuitry provides you with highly desired features and incredible versatility.

Only first-quality components are used throughout, and each board is rigorously tested to assure perfect and dependable performance.

### No Risk Trial.

We are so convinced that you will be absolutely delighted with our boards that we extend a no-risk trial offer. After purchasing one of our boards, you may return it (intact) for any reason within 15 days after shipment and we will refund the purchase price (less shipping).

### NEW S-100 PRODUCTS COMING SOON:

- \* DUAL 8/16 BIT CPU BOARD
- \* 128K 8/16 BIT STATIC RAM
- \* 256K 8/16 BIT DYNAMIC RAM

# \$629.

48K PARTIALLY POPULATED \$519.  
32K PARTIALLY POPULATED \$409.

### 64K RAM, MODEL MM65K16S

- 64K x 8-bit
- Speed in excess of 6 MHz
- Uses 150ns 16K (2K x 8) static RAMS
- Ultra-low power (435 Ma. max. — loaded with 64K)
- Bank Select **and** Extended Addressing
- A 2K window which can be placed anywhere in the 64K memory map
- Four independently addressable 16K blocks organized as:
  - Two independent 32K banks **or**
  - One 64K Extended Address Page **or**
  - One 48K and one 16K bank for use in MP/M<sup>1</sup> (option)
- Each 32K bank responds independently to phantom
- 2716 (5V) EPROMS may replace any or all of the RAM
- Field-proven operation in CROMEMCO CROMIX\* and CDOS\*.
- Compatible with latest IEEE 696 systems such as Northstar, CompuPro, Morrow, IMS, IMSAI front panel, Altair and many others.

OEM and DEALER inquiries invited.

**MM** Memory Merchant™

14666 Doolittle Drive  
San Leandro, CA 94577  
(415) 483-1008

## FULL TWO-YEAR WARRANTY.

The reliability of our boards, through quality-controlled production and proven performance, has enabled us to extend our warranty to a full two years. That's standard with us, not an option. This includes a 6-month exchange program for defective units.

### Shipped direct from stock.

All Memory Merchant's boards are shipped direct from stock, normally within 48 hours of receipt of your order. Call us at (415) 483-1008 and we may be able to ship the same day.

### 16K RAM, Model MM16K14



16K x 8 Bit 16K STATIC RAM \$169.

Bank Select & Extended Addressing  
Four independently addressable 4K blocks

One 4K segment equipped with 1K windows

Uses field-proven 2114 (1K x 4) RAMS  
Low Power (less than 1.2 Amps)  
Runs on any S-100 8080, 4 MHz Z-80 or 5 MHz 8085 system.

Prices, terms, specifications subject to change without notice.

\*Cromix and CDOS are trademarks of CROMEMCO  
<sup>1</sup>MPM is a trademark of Digital Research

ing a digital rate multiplier to the 1.22-MHz system clock, the signal input to the SC-01A can be made programmable to produce smaller and better-defined pitch inflections.

IC19 in the Microvox is a 6-bit binary rate multiplier. Its output frequency obeys the function:

$$F_{OUT} = M \times F_{IN}$$

where

$$M = b_5 \times 32 + b_4 \times 16 + b_3 \times 8 + b_2 \times 4 + b_1 \times 2 + b_0 \times 1$$

( $b_5$  through  $b_0$  being the six multiplier bits) and

$$F_{IN} = 1.22 \text{ MHz}$$

When the SEL4 strobe is activated, a 4-bit inflection code is latched into IC13 (a 74LS175 quad D flip-flop) and applied to the rate multiplier. The 4-bit combination (corresponding to a hexadecimal value of 0 to F loaded into IC13) selects one of 16 clock rates that range from 614.4 kHz to 902.4 kHz in 19.2-kHz increments. The frequency

change of near 20 kHz creates a relatively small pitch change by itself (out of a 720-kHz nominal input frequency), but, used dynamically in a sentence, it is just what the doctor ordered for syllable inflection.

Remember that the 2 manual-inflection bits are still available to the user; they are set by 2 bits on IC11 (SEL3). I refer to the level set by these bits as the "base pitch" and the 16 frequencies from the rate multiplier as the "clock rate." The combination of the 2 functions results in 64 pitch levels or inflections.

The pitch at which individual phonemes are pronounced may be controlled automatically by the text-to-speech algorithm, kept fixed, or altered by user command. Some people prefer automatic inflection, because of the variety it gives to the speech. Others think a computer should sound like a computer and prefer flat speech to artificially intoned speech. Still others may wish to directly control the pitch to make the unit sing (pitch and rate codes may be mixed with phoneme codes to produce singing) or to pronounce words with special emphasis.

The user may control the base pitch setting independently of the clock rate by issuing a pitch-control command:

!Px

where  $x$  is a digit from 1 through 4;  $x=1$  selects the lowest pitch with pitch increasing according to the value of  $x$ .

The user may also control the clock rate with a command of the form

!Ry

where  $y$  can take on values from 1 to 16;  $y=1$  selects the lowest pitch;  $y=16$  the highest.

### Musical Abilities

One final feature of the Microvox is the ability to play musical notes and produce sound effects by using a program routine to toggle one bit of the PIA (IC11) at a predetermined rate. This line is connected to the output audio amplifier along with the output from the speech synthesizer

## 9600 BAUD ONLY \$315. NEW LCM-100\* SYSTEM

**Economical.** The LCM-100 permits economical full-duplex, asynchronous data transmission over your existing 120V power lines. You eliminate costly RS-232 cable installation and can achieve an efficient 9600-baud data transfer rate with significant savings.

**Plug-in Convenience.** Each system contains two LCM-100 transceivers. Use the LCM-100 system to connect a terminal, processor, or printer, to your computer via any 120V outlet.

**Aid Productivity.** Staff can quickly relocate terminals where they are needed, reducing unprofitable waiting time, and allowing them to work at their desks where they are most efficient. Allows noisy printers to be placed in less disturbing locations.

**Reduce Overhead.** Instead of dedicating fixed cables to many office locations, use of the LCM-100 can cut costs by permitting terminals to be quickly and conveniently moved to where need exists.

Dealer inquiries invited, ask about our special dealer package.  
Orders and inquiries call 1-800-426-8075.  
Alaska, Hawaii & Washington State Call Collect

\*Line Carrier Modem



COMMUNICATIONS RESEARCH CORPORATION

1720-130TH AVENUE N.E. BELLEVUE, WASHINGTON 98005  
A SUBSIDIARY OF ENERGY SCIENCES CORPORATION (206) 881-9550



# CHART-MASTER™

## Business Graphics Software

### Professional-Quality Graphics from Personal Computers

*CHART-MASTER works with Apple® II, Apple® III and IBM personal computers to create full-color business graphics on Hewlett-Packard plotters, including the new low-cost H-P 7470A.*

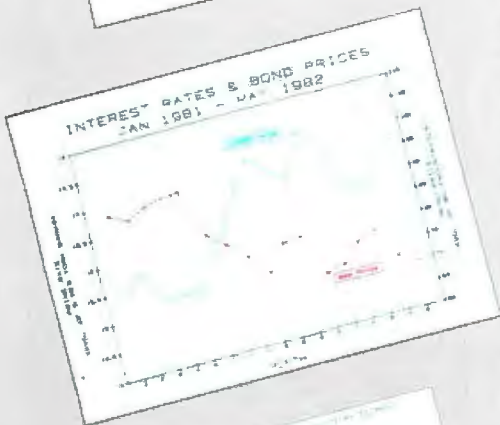
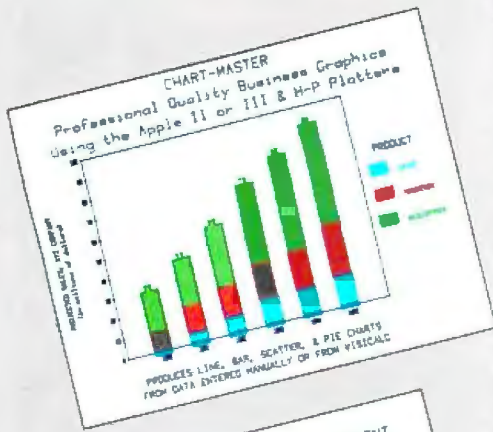

#### POWERFUL

*CHART-MASTER produces bar charts, line charts, scatter diagrams and pie charts, as well as text pages and signs, on paper or acetate (transparencies). Data can be entered manually or automatically from Visicalc® and other programs. Charts can be edited, stored and retrieved.*

#### FLEXIBLE

*CHART-MASTER allows you to select from a broad range of options to create the chart that best communicates your data. Options include producing up to nine charts per page, footnote and framing capabilities, left and right y-axes, a variety of hatching and line types, exploded pie segments, linear regression and curve-fittings, logarithmic axes and much more.*

#### EASY TO USE

*CHART-MASTER is an interactive, menu-driven program that allows users, whether managers or secretaries, to produce presentation-quality charts immediately with little or no training. It is easy for you to enter data, choose options, select a chart format ... and let CHART-MASTER do the rest.*

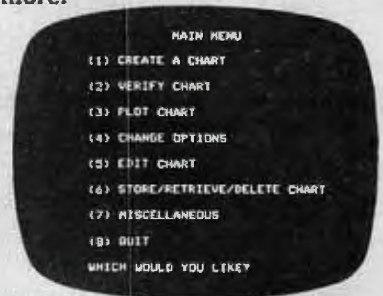

#### COST-EFFECTIVE QUALITY

*To get the same high quality that CHART-MASTER delivers, you would have to use expensive time-sharing services, commissioned graphic artists or costly dedicated graphics systems. Thus, CHART-MASTER, especially when teamed with the new Hewlett-Packard 7470A plotter, represents a price/performance breakthrough. Users of these more costly methods will find that a CHART-MASTER/Hewlett-Packard combination pays for itself in just a few months. And, because CHART-MASTER also offers convenience, speed, user control and versatility, you will find that you will increase your use of business graphics at no marginal cost.*

*CHART-MASTER is available through your local computer dealer for \$375. A complete graphics plotting package, consisting of CHART-MASTER, H-P 7470A plotter and interface for your Apple or IBM personal computer, costs as little as \$2000. For further information and the name of your nearest dealer, call or write:*

**Decision Resources** Professional software tools

PO Box 309, Westport CT 06880, 203/222-1974

Apple is a trademark of Apple Computer, Inc.  
Visicalc is a trademark of Personal Software, Inc.

Circle 154 on Inquiry card.

chip (IC12). The results are similar to the sound produced by the internal speaker of an Apple II computer using the same technique.

While the Microvox is not exactly a virtuoso instrument, programming it to play a simple tune is not hard at all. The music mode is turned on by the command:

IN

Once the music mode has been activated, a different set of note-specifying commands is used.

In the music mode, notes may be chosen from a range of 3 octaves centered on middle C, indicated by numbers from 1 to 3. Each octave contains notes identified as A, B, C, D, E, F, or G. Sharps are indicated by the suffix character "+", flats by "-". Time values are selected by reciprocal numeric arguments: the length of a note may vary from a whole note (length of 1) to a 128th note (length of 128). Rests are indicated by "R". When in the music mode, sending Microvox the character string "3F+4" causes it to play a quarter note at a pitch of F sharp in the third octave. "R16" causes a sixteenth-note rest.

Notes of unconventional lengths may be used; for instance, the software supports "thirty-seventh" notes. Tempo may set from values of 50 to 128 beats per minute by a command of the type "Tx" with x in the proper range. The default tempo is 80.

### To Be Continued . . .

I apologize if I am jumping ahead too quickly. It's just that I want you to be assured that these hardware features of music and programmable pitch are not an overcomplication; they are easily accommodated in the software.

Obviously, there is no conclusion this month. I'll have a lot more to say next month. And keep in mind that while the main object of this project is an easy-to-use text-to-speech synthesizer, the computer section of the circuit has some special merit of its own. You may expect to see the same 6502-based control-computer design in future Circuit Cellar projects.

### Next Month:

We'll take a look at the software and operation of the Microvox speech synthesizer. ■

### References

1. Anderson, James C. "An Extremely Low-Cost Computer Voice Response System," BYTE, February 1981, page 36.
2. Barden, William Jr. "Voice Synthesis for the Color Computer: Third in a Series," BYTE, February 1982, page 258.
3. Blankenship, John. "Give Your Apple a Voice: A Speech-Development System Using the Radio Shack Speech Synthesizer," BYTE, May 1982, page 446.
4. Ciarcia, Steve. "Build a Low-Cost Speech-Synthesizer Interface," BYTE, June 1981, page 46. Reprinted in *Ciarcia's Circuit Cellar, Volume III*, Peterborough, NH: BYTE Books, 1982, page 133.
5. Ciarcia, Steve. "Build an Unlimited-Vocabulary Speech Synthesizer," BYTE, September 1981, page 38. Reprinted in *Ciarcia's Circuit Cellar, Volume III*, Peterborough, NH: BYTE Books, 1982, page 168.
6. Ciarcia, Steve. "Talk to Me: Add a Voice to Your Computer for \$35," BYTE, June 1978, page 142. Reprinted in *Ciarcia's Circuit Cellar, Volume I*, Peterborough, NH: BYTE Books, 1979, page 77.
7. Fons, Kathryn and Tim Gargagliano. "Articulate Automata: An Overview of Voice Synthesis," BYTE, February 1981, page 164. (See also "BYTE's Bugs: Upside-Down Static Phoneme," BYTE, May 1981, page 232.)
8. Gargagliano, Tim and Kathryn Fons. "A Votrax Vocabulary," BYTE, June 1981, page 384.
9. Gargagliano, Tim and Kathryn Fons. "Text Translator Builds Vocabulary for Speech Chip," *Electronics*, February 10, 1981, page 118.
10. Gargagliano, Tim and Kathryn Fons. "The TRS-80 Speaks: Using BASIC to Drive a Speech Synthesizer," BYTE, October 1979, page 113.
11. Lin, Kun-Shan, Gene A. Frantz, and Kathy Goudle. "Software Rules Give Personal Computer Real Word Power," *Electronics*, February 10, 1981, page 122.
12. Miaszkowski, Stan. "Add a Voice to Your Computer: The Votrax Type-'N-Talk,'" *Popular Computing*, June 1982, page 81.
13. Payne, Robert A. "A Voice for the Apple II Without Extra Hardware," BYTE, November 1981, page 499.

To receive a complete list of Ciarcia's Circuit Cellar project kits available from the Micromint, circle 100 on the reader service inquiry card at the back of the magazine.

The following are available from:

Intex Micro Systems Corporation  
Suite 717  
755 West Big Beaver Road  
Troy, MI 48084  
(313) 362-4280

1. *Intex-Talker, the assembled, tested, and FCC-approved version of the Microvox text-to-speech synthesizer. With power supply and documentation. . . . . \$295. OEM pricing and availability will be discussed on request. Michigan residents please include 4 percent sales tax. Please include \$4 for shipping. Overseas orders add \$20 for shipping.*

★ ★ ★

The Micromint Inc.  
917 Midway  
Woodmere, NY 11598  
(516) 374-6793

(for technical information)

(800) 645-3479

(for orders only)

1. *Complete kit for building the Microvox text-to-speech voice synthesizer, including the SC-01A and all other components, enclosure, power supply, and documentation. . . . . \$215. Overseas orders add \$20 for shipping.*

2. *Votrax SC-01A voice-synthesizer chip. . . . \$70 each. Call for OEM pricing and availability.*

*Residents of New York please include 7 percent sales tax. Please include \$4 for shipping on all orders.*

Editor's Note: Steve often refers to previous Circuit Cellar articles as reference material for each month's current article. Most of these past articles are available in reprint books from BYTE Books, 70 Main St., Peterborough, NH 03458. Ciarcia's Circuit Cellar, Volume I, covers articles that appeared in BYTE from September 1977 through November 1978. Ciarcia's Circuit Cellar, Volume II, contains articles from December 1978 through June 1980. Ciarcia's Circuit Cellar, Volume III, contains the articles that were published from July 1980 through December 1981.

# Test drive the Victor desktop computer designed for systems.

Like a high performance automobile, the Victor desktop business computer needs to be put to the test to be really appreciated. Here's why:

## **The computer dilemma.**

Systems houses today face a basic dilemma when it comes to selecting a computer.

The so-called "personal" computers on the market are like "economy" cars. They're relatively inexpensive but have limited power and capacity.

And the larger mini computers offer more power and speed, like a luxury car, but are, of course, more expensive.

Victor has a solution to that dilemma.

The Victor 9000 Business Computer is retail priced under \$5,000. If you sell computer systems, quantity purchase agreements will let you be very aggressive.

## **Great visibility –**

800x400 pixels – graphics – 80x25 characters (soft-loaded) green phosphor – anti-glare – bit mapped.

## **Design for comfort**

– display screen tilts 0°-11° and swivels ±42° to suit the operator.

## **Power under the hood**

– 8088 – 5Mhz-2 RS232 ports – 2 parallel ports – CODEC4 bus slots.

## **Ease of handling**

– up to 103 keys – capacity switches – sculptured – soft-loaded – 6 foot cord

The Victor gives your systems the kind of memory and storage capacity advanced applications demand. Much more than comparably priced machines.

And the Victor display screen has double the resolution and capacity of its competitors. You can display a full 132-column report and still be perfectly readable. Is that important to your system? Ask any programmer.

## **Experience where it counts.**

But those are only the technical advantages of the Victor 9000. Equally important is Victor's 65 years of experience in solving business problems. And Victor's 50 branch offices throughout the country providing fast service and total support.

## **Software tools to keep you growing.**

Victor supplies CP/M-86 and MS-DOS with every machine. Runtime support

for Basic, Cobol, Fortran and Pascal is no extra cost. The Victor 9000 has the tools you need to do the job right.

The Victor 9000. It's a desktop system computer designed to be a "cut above" the rest. Whether you sell complete systems, or are just looking for the best computer to support your software, call your Victor OEM specialist today. Or get in touch with Victor at (800) 621-5559. In Illinois (800) 972-5858. We're open 24 hours a day, 7 days a week.

# VICTOR®

Serving American business for 65 years.

**VICTOR® BUSINESS PRODUCTS**

Subsidiary of Kiddle, Inc.  
KIDDE



## **Fuel for thought –**

CP/M-86 – MS-DOS – CBASIC – Basic 86-MS-Pascal-CIS-COBOL MS-Fortran – MS-COBOL – Multiplan – VictorWriter

## **Compact efficiency**

– 302 square inch foot print – all components separate – organize it yourself

## **Excellent mileage –**

The Victor Business Computer takes your system further for less money. Test drive it and compare.



# Now you don't have to decide between a personal computer and a VT100 terminal.

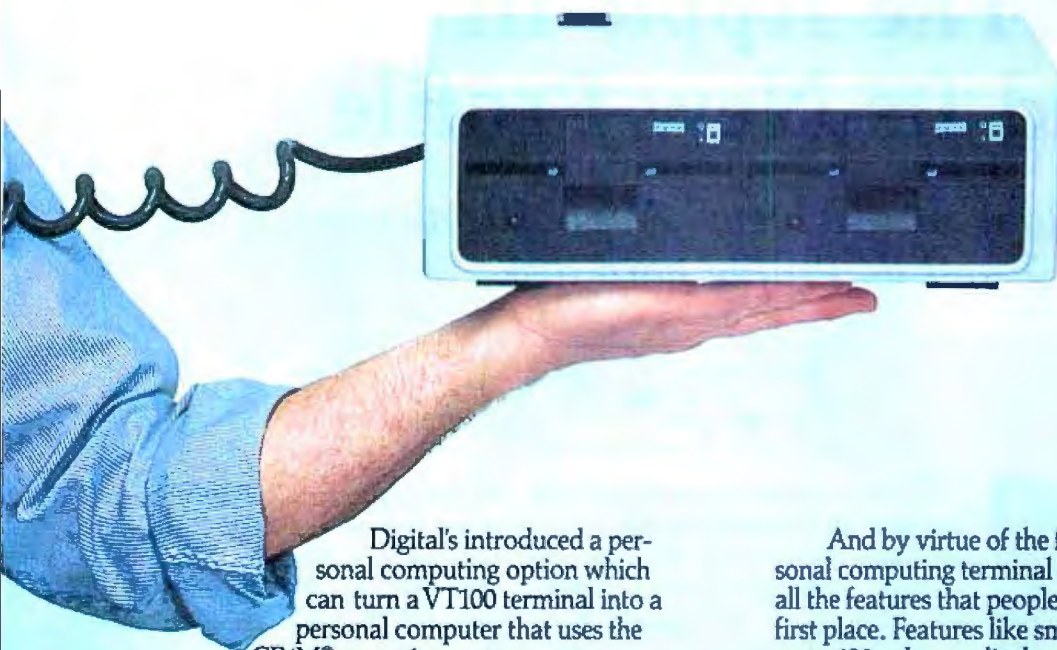

Digital's introduced a personal computing option which can turn a VT100 terminal into a personal computer that uses the CP/M® operating system.

It's called Digital's Personal Computing Option. You can purchase just the option, or you can buy the complete terminal/computing package called the VT180.

Either represents significant advantages over the choices available to you now. For now, you can provide access to a large computer and personal computing at the same terminal.

More than that, you save the additional cost of putting personal computers and terminals side by side on the top of a desk.

With the CP/M operating system Digital's personal computing terminal will run the literally hundreds of programs available for it. Including word processing, mailing lists, financial modeling, statistics, even data base communications—in addition to the many more being specially edited for this terminal.



And by virtue of the fact that Digital's personal computing terminal is VT100-based, you get all the features that people buy VT100s for in the first place. Features like smooth scrolling with up to 132 columns display, split-screen viewing, double-height and width characters, and reverse video.

Plus a reputation that's second to none in the industry. Plus Digital's service, on-site, anywhere in the world.

All of this should make great sense when you're confronted with the choice of terminals or personal computers.

Because now you can pick one and get both.

See your Digital dealer for more information or write: Digital Equipment Corporation, Terminals Product Group, 2 Mt. Royal Avenue, UPI-5, Marlboro, MA 01752. Telephone toll-free 800-225-9378 (outside the continental U.S. or in Massachusetts call 617-480-4077) between 8:30am and 5:00pm Eastern time. In Europe: 12 Av. des Morgines, CH-1213 Petit-Lancy/Geneva. In Canada: Digital Equipment of Canada, Ltd.

**digital**

Circle 159 on inquiry card.

CP/M® is a registered trademark of Digital Research, Inc.

## The Apple III and Its New Profile

*An in-depth look at the "new" Apple III microcomputer  
and its Profile hard disk.*

---

Robin Moore  
Warner Hill Rd. RFD #5  
Derry, NH 03038

---



**Photo 1:** A view of the Apple III, the Profile hard-disk drive, and the Monitor III showing a sample of Visicalc III on the screen.

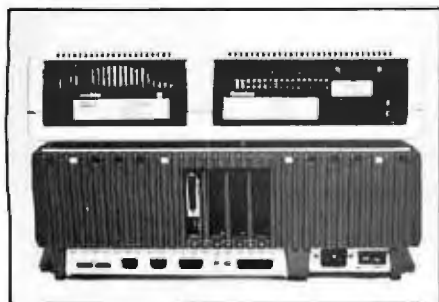

**Photo 2:** A rear view of the Apple III and Profile showing the Silentyper and game paddle ports A and B, along with the video, audio, RS-232C, and floppy-disk connectors. The peripheral card visible is the Profile interface card.

In 1980 when the Apple III was first released, there were problems. Deliveries were delayed, and when the machines finally arrived, they often didn't work. The integrated circuits tended to wander out of their sockets. Little software except Visicalc was available, and the much-promoted real-time clock/calendar didn't work well. The Apple III was, on the whole, unreliable. It was a bad start.

Now, in 1982, the problems are gone. The sockets have been changed and the software bugs fixed. The Apple III has been rereleased with revised software, Pascal, and a brand-new peripheral—the Profile, a 5-megabyte hard-disk drive. The new Apple III is an impressive machine and certainly a contender for the title of Best Personal Computer in the less than \$10,000 class.

### System Overview

Let's take a closer look. The Apple III is a single unit that includes the central processing unit, keyboard, memory, floppy-disk drive, and video output (see photos 1 and 2). It has been designed to meet the needs

of the professional or small-business user. Instead of offering an initial low-cost unit requiring a number of additions, Apple Computer Inc. has included the most common system expansions as standard in the Apple III. These include an enhanced keyboard, a 24-row by 80-column display, an integral disk drive, 128K bytes of memory, a programmable 128-character set, improved high-resolution graphics, and an Apple II emulation program (see the At a Glance box for additional features and details).

In addition, several peripherals are available for the Apple III. The most impressive of these is the Profile, Apple's new 5-megabyte hard-disk drive. (The Profile will be described in detail later in this article.) Other options from Apple Computer in-

---

### About the Author

Robin Moore is manager of microprocessor development for A. B. Dick Co. and maintains a strong interest in FORTH, graphics, and computer music. He is also librarian for the Southern New Hampshire Apple Core.

---

# CRUSH THE KRYON EMPIRE IN ENLIST MEGA WARS



MegaWars, a real-time space battle

between the forces of the Colonists and the Kryon Empire. Join an intergalactic shootout with up to eight starship commanders transmitting orders from the keyboard cockpits of their craft anywhere in the U.S.A.

## THE ULTIMATE COMPUTER CONFLICT

Attacking, evading, scanning, communicating. That's MegaWars. Easy to learn but difficult to master. That's why CompuServe will give one free hour to every MegaWars player entering a game before December 31, 1982.

Call toll free  
800-848-8990.

You'll receive the illustrated guide to CompuServe, America's most comprehensive Videotex service, plus the MegaWars Commanders Briefing.

### CompuServe

5000 Arlington Centre Blvd.  
Columbus, Ohio 43220  
800-848-8990

Circle 102 on Inquiry card.

# ERG/68000 MINI-SYSTEMS

- Full IEEE 696/S100 compatibility

## HARDWARE OPTIONS

- 8MHz or 10 MHz 68000 CPU
- Memory Management
- Multiple Port Intelligent I/O
- 64K STATIC RAM (70 nsec)
- 256K Dynamic RAM, with full parity (150 nsec)
- 8" D/D, D/S floppy disk drives
- 5MB-32MB hard disk drives
- Full DMA host adaptor
- 20MB tape streamer
- 10 to 20 slot backplane
- 30 amp power supply

## SOFTWARE OPTIONS

- 68KFORTH<sup>1</sup> systems language with MACRO assembler and META compiler
- Fast Floating Point package
- Motorola's MACSBUG
- IDRIS<sup>2</sup> operating system with C, PASCAL, FORTRAN 77, 68K-BASIC<sup>1</sup> compilers

Trademark <sup>1</sup>ERG, Inc.  
<sup>2</sup>Whitesmiths

30 day delivery  
with valid Purchase Order

OEM prices available  
For CPU, Integrated Card Sets  
or Systems.



Empirical Research Group, Inc.  
P.O. Box 1176  
Milton, WA 98354  
206-631-4855

## At a Glance

### Name

The Apple III Computer

### Manufacturer

Apple Computer Inc.  
20525 Mariani Ave.  
Cupertino, CA 95014  
(408) 996-1010

### Components

#### System Unit

Size: width 17.5 inches (44.45 cm), depth 18.2 inches (46.23 cm), height 4.8 inches (12.19 cm)  
Weight: 26 pounds (11.8 kg)  
Power Required: 107-132 volts AC, 60 Hz, 100 watts maximum  
Processor: 6502B [2 MHz] with bank switching and enhanced indirect addressing, double stack and zero pages  
Memory: 128K bytes of dynamic RAM (expandable to 256K bytes), 4K bytes of self-test and boot-loader ROM  
Standard: keyboard for text and data entry; programmable RS-232C serial communications/printer interface; power-up self-check and disk bootstrap; both color-graphics and black-and-white/gray-scale graphics video outputs; two game-paddle/joystick connectors; three audio generators—fixed beep, 1-bit programmable, and 6-bit A-D converter; one 140K-byte 5¼-inch floppy-disk drive

#### Video Display:

Three Text Modes  
24 by 80, black and white, normal and inverse  
24 by 40, black and white, normal and inverse  
24 by 40, 16 color characters on 16 color backgrounds  
All text modes have software-definable 128-character sets  
Four Graphics Modes  
280 by 192, 16-color foreground and background with limitations  
280 by 192, black and white  
140 by 192, 16 colors with no limitations  
560 by 192, black and white

#### Video Outputs:

Both black-and-white/gray-scale and color-graphics outputs providing NTSC monochrome composite video, NTSC color composite video, or 4-bit coded RGB color with a separate composite synchronization signal

#### Keyboard:

74 keys for text and data entry; includes 13-key numeric pad for fast numeric entries, four cursor control keys with two-speed auto-repeat, three special-function keys, and text keys that allow entry of all 128 ASCII characters; SOS software provides a 128-character type-ahead keyboard buffer; all keys automatically repeat after ½ second

#### Disk Drives:

System supports up to four 140K-byte 5¼-inch floppy-disk drives using Apple-format 6/8 GCR (group-coded recording) encoding

### Operating System

Apple III SOS 1.1 (Sophisticated Operating System); single task, interrupt-driven, configurable operating system with hierarchical file structure, multiple file protection levels, and device-independent byte-oriented I/O

### Special Features

An Apple II emulation mode that allows use of almost all existing Apple II software; utilities that allow transfer of DOS text files, Visicalc files, and Pascal files from the Apple II to the Apple III

### Software Available for the Apple III

Visicalc III \$250; Applewriter III \$225; Apple III Pascal \$250; Business BASIC \$125; Apple Access III (communications software) \$150; Apple III Business Graphics \$175; Pascal Utility Library \$75; Script III \$125; Mail List Manager \$150; all from Apple Computer Inc.

### Hardware Prices (Apple Computer Inc)

Apple III 128K-byte system	\$3495
Apple III 256K-byte system	\$4295
Additional disk drives (three maximum)	\$495
Profile 5-megabyte Winchester hard disk-drive and interface card	\$3,499
Universal parallel interface card	\$225
Apple Monitor III (monochrome/green screen)	\$320
Game controllers	\$29.95



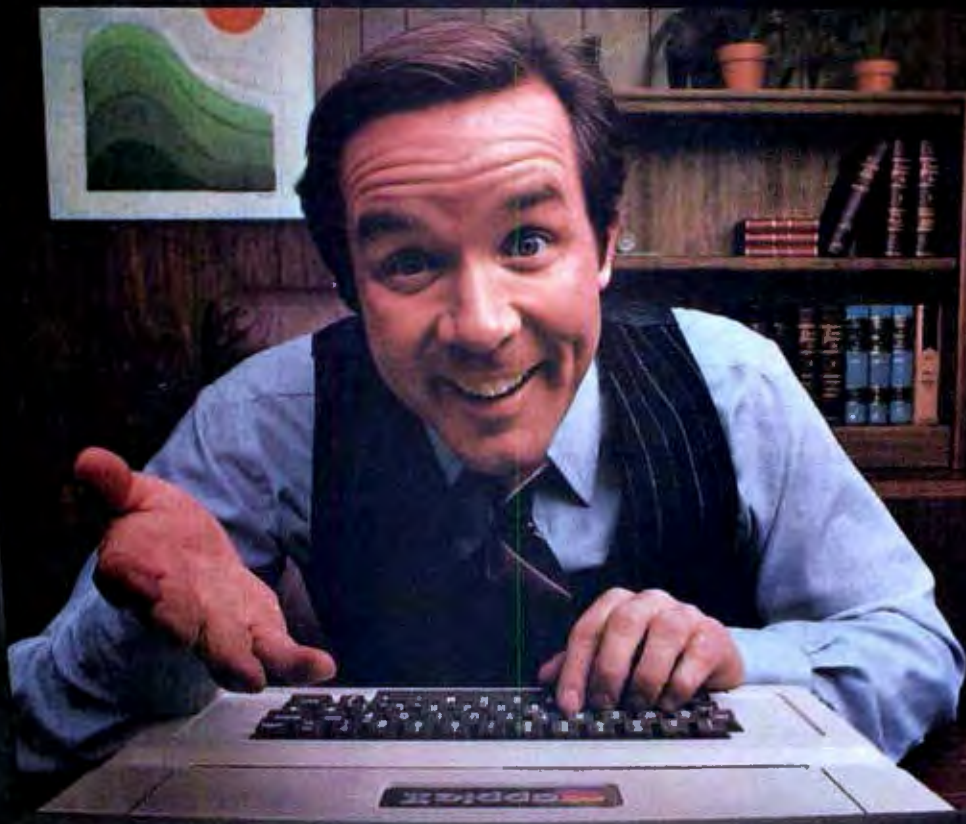

# "THAT'S IT!"

There's nothing like the feeling you get when you've got the solution.

And nothing else will help you solve problems better, smarter, faster than the Visi™ programs for your personal computer.

For example, our VisiCalc® program: It's #1 in the business because it takes the work out of working with business numbers. The VisiCalc program is the powerful "electronic worksheet" that speeds planning and budgeting. It lets you ask "what if?" and see the answers immediately. So you can analyze the impact of decisions before you make them.

Our VisiTrend/Plot™ program combines graphics with forecasting and statistics. It automatically performs complex calculations and produces charts and graphs. So you can analyze the past, forecast the future and plot your results in an easy-to-understand visual form.

In addition, our series includes the VisiFile™, VisiDex™, VisiSchedule™, VisiPlot™, VisiTerm™ and Desktop/PLAN™ programs.

But the Visi programs are far more than individual problem-solvers. They're all inter-related, just like your needs and tasks, to give you a fully integrated solution.

All of the Visi programs work in much the same way, and they automatically interchange data, too. So it's easy to learn and use any of them, work in many different ways with all of them.

They're brought to you by VisiCorp™. The one company whose only business is helping you make the most of the personal computer in your business.

Ask your retail computer

store salesperson for a demonstration of the Visi series. They'll help you and your computer do all the things you're intent on doing.

THE VISI SERIES FROM  
VISICORP™  
PERSONAL SOFTWARE™

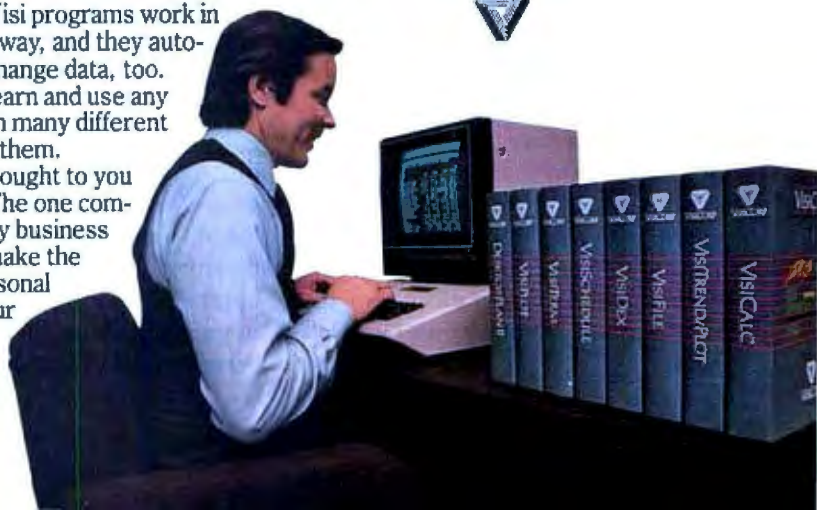

#### Apple III (list prices)

128K-byte system unit with integral 140K-byte 5 1/4-inch floppy-disk drive, Apple SOS operating system software, both color-graphics and black-and-white/gray-scale video outputs, RS-232C serial interface, game control port, and Silentype printer interface	\$3495
additional floppy-disk drive (three maximum)	\$495
Apple Business BASIC software	\$125
total	\$4115

#### IBM Personal Computer (suggested retail prices)

48K-byte system unit, disk-adaptor card, one 160K-byte floppy-disk drive, DOS software, Disk BASIC	\$2235
16K bytes of added memory and game adapter card	\$145
additional floppy-disk drive (one maximum)	\$570
serial RS-232C interface card	\$150
additional 64K-byte memory card	\$540
color-graphics video adapter card	\$300
Microsoft extended BASIC software	\$40
total	\$3980

**Table 1:** Price comparison of comparable versions of the Apple III and the IBM Personal Computer. Both systems include 128K bytes of memory, two floppy-disk drives, color-graphics video output, serial RS-232C interfaces for Qume (or equivalent) letter-quality printers, and game-paddle adapters. The system chosen is one that might be purchased by people who wish to combine business and personal applications. Note that in this configuration the IBM has used up all its expansion slots, while the Apple III still has all four of its slots left for further expansion.

clude the Silentype thermal printer, additional floppy-disk drives, the monochrome green-screen Monitor III, a universal parallel I/O (input/output) interface card, and game controllers.

Many of the existing Apple II interface cards will work in an Apple III while in the Apple II emulation mode. However, use of Apple II cards in an Apple III will probably make it exceed FCC (Federal Communications Commission) radio-frequency radiation limits and may cause interference on nearby television sets or radios. In addition, Apple II cards are not compatible with Apple III software unless special *device-driver* routines are written, and Apple provides virtually no information on how to write them.

Apple Computer currently provides a variety of software packages for the Apple III in addition to Business BASIC and Apple Pascal. There are also various hardware and software products available for the Apple III from other vendors and the number of these will increase as the Apple III user community grows.

The only software built into the Apple III is a 4K-byte ROM (read-only memory) that holds power-up self-test and disk bootstrap routines. All other software is loaded from disk. Although this means that languages use up some of the available RAM (random-access read/write memory), it also allows easy software upgrades and fixes that would be more difficult if the software were permanently in ROM.

## System Pricing

The approach to Apple III pricing is almost directly opposed to the pricing strategy used for the Apple II and the IBM Personal Computer. Because Apple chose to include a large number of standard features, the Apple III has a relatively high initial cost (\$3495); however, it can expand to 256K bytes of memory, four floppy-disk drives, and a letter-quality Qume (or equivalent) printer without using *any* of the expansion slots. A fully usable system can be configured by adding just a video monitor and an inexpensive serial printer.

Table 1 shows a price comparison of the Apple III and the IBM Personal Computer. Both systems are configured with 128K bytes of memory, two floppy-disk drives, a serial RS-232C printer interface, color-graphics video outputs, and game controllers. The IBM system costs slightly less but uses all of its expansion slots, while the Apple III still has its four slots available for future growth.

## The Apple III User

A look at the documentation and software supplied with the system will quickly reveal that the Apple III is targeted for professional and small-business users. Clear tutorials and example programs on disk demonstrate most system functions and features. There is even a two-disk program to lead you through the keyboard and display functions step by step.

The Apple III is not designed for the home hobbyist. Much of the technical information included with the Apple II is absent in the Apple III package. There is no discussion of bus structure, I/O addressing, memory usage, or screen-memory mapping. There are no listings published for any of the system software, either in the Apple III ROMs or on disk. Apple does not even tell you about the monitor program included in the ROMs (which is accessible by holding the Control and Open-Apple keys while pressing Reset).

All this technical information is unimportant to business users. They are more interested in *using* the Apple

# FREE CATALOG OF COMPUTERS AND SOFTWARE

- Easy-to-build Heathkit® Computers for hobbyists
- Typewriter-quality printers, smart video terminals
- Reliable service, friendly advice
- Fully assembled Zenith Data Systems Computers for business
- Heath User's Group library of 500 programs for home, work or play
- Wordprocessing – accounting – Super-Calc™ – small business applications
- Self-study courses for writing your own programs

## HEATH/ZENITH

Your strong partner

Yes, send me my free Heathkit Catalog. I am not currently receiving one.

**name** \_\_\_\_\_

**address** \_\_\_\_\_

**city** \_\_\_\_\_

**state** \_\_\_\_\_ **zip** \_\_\_\_\_

**FREE**

**HEATHKIT  
CATALOG**

**PLACE  
STAMP HERE**  
Post Office  
will not  
deliver mail  
without postage

**HEATH COMPANY**

Benton Harbor, MI 49022

# Let's get personal...

try out the in-stock selection of Heath/Zenith microcomputers, peripherals, accessories and software.

Now available at your nearby Heathkit Electronic Center, or through the Heathkit mail order catalog.

You get more with a Heath/Zenith personal microcomputer system! We offer:

**1. Proven high-performance hardware:** Thousands of our microcomputers prove themselves daily, in the field.

**2. Vast software library:** Three operating systems (including CP/M), languages, word processors, an electronic spreadsheet, versatile utilities and the 500-program Heath Users' Group software library.

**3. Self-instruction courses:** Evaluation and programming courses from Heathkit/Zenith Educational Systems.

**4. Service support:** Before and after the sale - consultation by phone, carry-in service by trained technicians.

**Test run one of our microcomputers at any of the more than 60 convenient Heathkit Electronic Centers in the U.S.**

## Heathkit<sup>®</sup> ELECTRONIC CENTERS\*

See the white pages of your telephone book for store locations and telephone numbers.

\*Units of Veritechnology Electronics Corporation in the U.S.

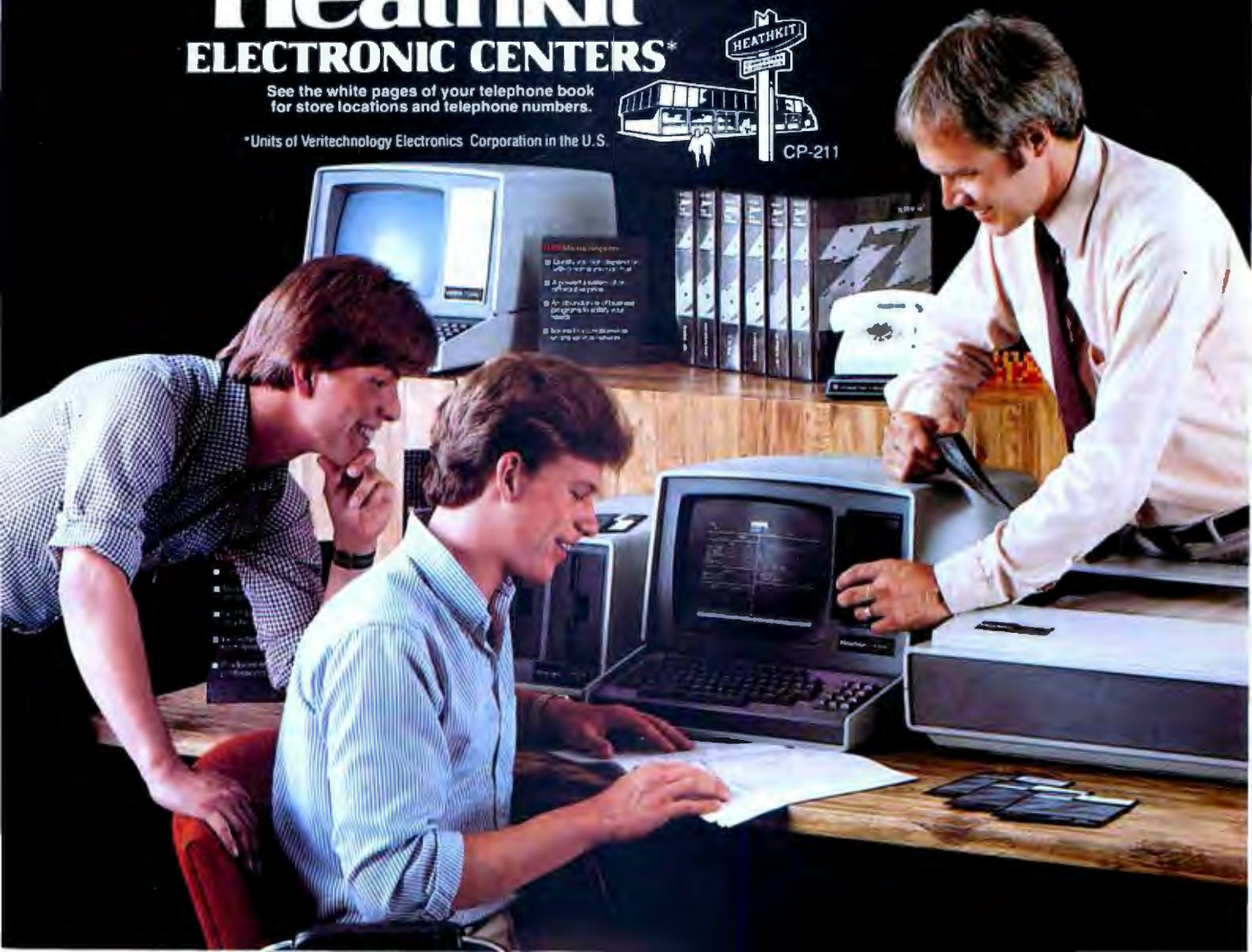



*Photo 3: The Apple III with its main cover removed. The power supply is housed in the enclosure visible to the left, I/O card slots are in the center, and the disk drive is on the right. The entire Apple III is built around a single thin-wall aluminum casting that provides both support and shielding.*

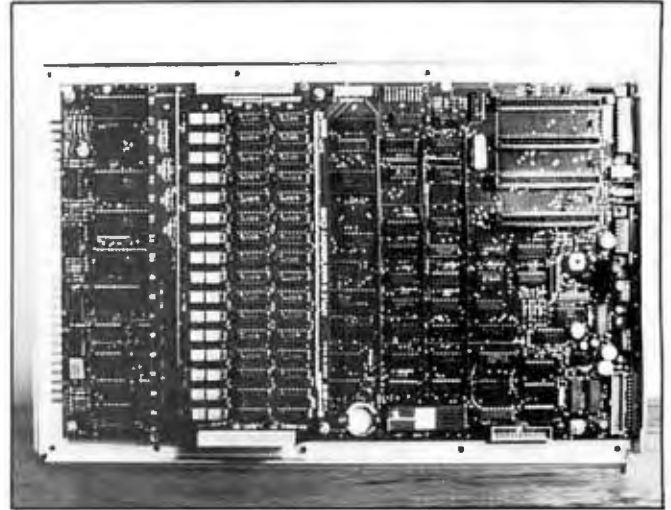

*Photo 4: The Apple III main PC board. The piggy-back-mounted board to the left of center is the removable main memory board. Using this board, the Apple II can be expanded to its full memory capacity without using up any of its I/O expansion slots.*

III than in dissecting it, and will, in most cases, use commercial software. The Apple III is admirably designed to serve their needs. For hobbyists there are better choices, namely, the Apple II.

### Inside the Enclosure

The Apple III is a fine example of a quality product designed for high-volume production. The entire unit is built around a single thin-wall aluminum casting that provides support and shielding as well as heat dissipation so that no cooling fan is required. The expansion card guides are molded into the casting, and fully enclosed boxes are built in for both the main printed-circuit (PC) card and the switching power supply (see photo 3).

All of the circuitry, except memory, is on one main PC board (see photo 4). The system memory board mounts piggy-back style onto the main board and avoids taking an expansion slot. In fact, the Apple III can be expanded to its full 256K-byte memory capacity in the same fashion, leaving all slots free.

The Apple III central processing unit is based on a 6502B microprocessor with custom external circuitry that provides a number of enhancements to the normal 6502 instruction

set. These enhancements include expanded addressing range, alternate stack and zero pages, and improved indirect addressing that is supported by a separate pointer page.

Although the technical information provided by Apple is somewhat vague, apparently the 6502B is run at 2 MHz during the video blanking in-

---

### **The Apple III can be configured to 256K bytes without using a single expansion slot.**

---

tervals and at 1 MHz while the beam is writing information onto your monitor screen. This provides an average speed of about 1.4 MHz, but the screen can be turned off temporarily during program execution to allow the processor to run at its full 2-MHz speed, if desired.

While a normal 6502B can address a maximum of 64K bytes of memory, the Apple III uses bank switching to expand this range to a theoretical maximum of 512K bytes.

Up to fifteen 32K-byte blocks of memory can be switched to occupy the range of addresses between 2000 and 9FFF hexadecimal. This switching

is handled automatically by the operating system and is totally "transparent"; that is, the switching executes in the background without affecting any task you may be performing in the visible foreground. It should be noted that, to date, Apple Computer has not announced any Apple III memory expansion beyond 256K bytes. Perhaps this will be a future option.

The main PC board also includes the disk controller, serial interface, video generation circuitry, and the expansion card slots. The expansion-bus connections in the Apple III are essentially the same as those in the Apple II, although DMA (direct memory access) is handled somewhat differently. The *Apple III Owners Manual* provides no information about the expansion bus. Hopefully, this type of information will be available in the future. There are few competing systems that do not make this sort of information available to the public.

### The Keyboard

Experienced typists should find the Apple III keyboard easy to use (see photo 5). Unlike the Apple II, this keyboard has a typewriter layout so that touch-typists should feel comfor-



## EXPAND VISICALC® ON APPLE® II

Do you need more memory for your VisiCalc models? Would you like to see them in 80 column display? Do you want hard disk support?

Then you need one of Saturn's VisiCalc expansion systems. For a fraction of the cost of a larger computer, you can create models you never dreamed possible on an Apple II.

With Saturn board(s) and software, you can increase your workspace to as much as 177K. With additional

hardware, you can get 80 column display and lower case letters. You can even use the Nestar hard disk system, if you wish.

Saturn's VC-Expand programs allow you to use the entire displayed VisiCalc matrix, and to save your large models on more than one diskette.

You can also use your Saturn boards to expand user programming capabilities, or to simulate a disk drive under DOS, PASCAL, or CP/M.®

Ask your retail computer store salesperson about Saturn's memory expansion systems. See how much bigger and better your VisiCalc models can become.



VisiCalc is a registered trademark of VisiCorp.  
 Apple is a registered trademark of Apple Computer, Inc.  
 CP/M is a registered trademark of Digital Research Corporation.

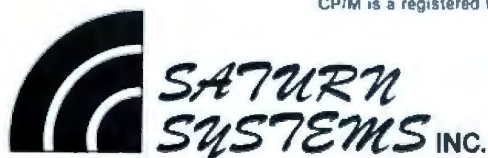

P.O. Box 8050 Ann Arbor, Michigan 48107  
 (313) 973-8422

# The Panasonic portable computer We've improved the way



## **The Link by Panasonic.**

It will improve the way you solve problems. And the solutions come from the portable computing power you have at your fingertips. You can take it with you on planes, cars, boats, anywhere, because it fits into a suitcase. You can be more cost effective in the field, because you'll have access to more information for making on-the-spot decisions. You'll have the incredible advantage of being able to telecommunicate from anywhere you are. It gives you a whole new world of computing. Portable computing.

**Software Solutions** — Now there's an exciting new software system for the 6502 microprocessor that gives you more

solutions to your problems.

The popular language software for the portable computer includes Extended Basic Compiler/Interpreter, SnapFORTH and Microsoft Basic.®

The Panasonic portable computer also has a wide range of specific software programs for your specific problems, such as:

**The Scientific Calculator** — An incredibly powerful tool that solves mathematical problems for the scientist, engineer, and professional wherever they go.

**Portabudget** — It's your portable personal financial manager. It gives you up-to-the-minute personal control. It allows you to be your own record keeper, savings advisor, accountant, bill manager, credit and charge account guide, investment counselor, portfolio keeper, and tax assistant. Overall, it helps plan your personal financial life, portably.

**Portacalc** — Gives you the portability and the flexibility to automatically analyze numerical problems wherever and whenever they arise. You can assess "what if" alternative business problems, comprehend key variables in business, and dynamically analyze problems on engineering projects.

**Portawriter** — It allows you to write, edit, and format information. And, you can telecommunicate the information from wherever you are. Whether you're in the boardroom, hotel room, or even on a golf course, Portawriter gives you full editing and formatting capability for notes, reports, letters, news copy, tables, lists, forms, orders, you name it.

**Portalog** — It is an easy, precise tool for time-billing professionals without a minute to lose. Whether you're on the road or in the office, you can log time, compile bills, generate billing reports, and track the work of your highly paid employees. Portalog gives you improved timekeeping productivity.

**Telecomputing 2™** — It lets you telecommunicate with your data base. You can establish communications between headquarters and field forces. Exchange files and programs between remote stations. Access timesharing services and store data in a large computer's mass storage. You can also upload and download program data.



# with a wide range of new software. you solve problems.

**Portaflex** — A master program that allows you to create solutions for applications, such as:

- *Inventory Control* — Analysis and control of inventory while you're on the job.
- *Order Entry* — A customized system for any sales order entry. It offers you productivity, and the advantage of faster order entry.
- *Field Service* — Retrieve, diagnose, and analyze your field service data wherever you are in the field.
- *Auditing and Accounting* — Custom auditing and accounting, anywhere you are in the field.
- *Estimating* — Versatility for flexible bidding and estimating at your job site.

**Software Development Tools for the Customizer** — Create your own custom programs and burn them into your EPROM so your program is recorded in nonvolatile form.

Simply take a desk top microcomputer,\* insert the software development discs, create your own program, de-bug that program, compile the program, then "burn-in" your problem-solving EPROM.

\*Presently offered for Apple II Plus

## Hardware Specifications —

The Panasonic portable computer offers 6502 microprocessor (1 MHz) technology.

- It offers 4K or 8K internal nonvolatile RAM
- 48K internal ROM
- Built-in Ni-Cad rechargeable battery pack
- External AC adapter/recharger
- 26-character liquid crystal display
- 65-key completely redefinable keyboard

## Introducing Peripherals for Additional Solutions —

Modular peripherals let you customize your system.

- Multiple RS-232C serial interfaces
- Asynchronous modem with cassette interface (110 or 300 baud)
- 40-character microprinter (thermal dot matrix printing)
- 8K or 16K RAM memory expansion packs
- X-Y, four-color plotter (up to 80 characters per line)
- TV adapter (32 characters X 16 lines with color and graphics)

The Panasonic portable computer. It's improved the way you solve problems. Because we believe its portable modules and multiple software applications can vastly improve your productivity. And that can be an important solution to your profit problems.

The portable computer from Panasonic. We've improved the way you solve problems.

## The **LINK** by Panasonic. It's changing the way the world uses computers.



Please send me more information.

Dealer Inquiries Invited

Panasonic Company, Hand-Held Computers  
One Panasonic Way, Secaucus, New Jersey 07094

Name (PLEASE PRINT) \_\_\_\_\_

Title & Company \_\_\_\_\_

Type of Business \_\_\_\_\_

Address \_\_\_\_\_

City \_\_\_\_\_ State \_\_\_\_\_ Zip \_\_\_\_\_

Phone Number ( ) \_\_\_\_\_

8-5

**Panasonic**  
just slightly ahead of our time.



Photo 5: The Apple III keyboard. Although it looks separate, it is actually part of the Apple III main enclosure.

table with the key placement. The layout of the numeric keypad on the right, which resembles that of a calculator, allows easy entry of numeric

data. The Apple III can also generate all 128 ASCII (American Standard Code for Information Interchange) codes without extra hardware.

In addition to the normal Shift, Control, and Caps-Lock modifier keys, the Apple III includes special Open-Apple and Close-Apple keys that you can define for special functions. All keys automatically repeat when pressed for more than 1/2 second, and the four cursor-movement keys each provide a 2-speed repeat—pressing gently repeats at 11 Hz, while pressing firmly repeats at 33 Hz.

Apple's SOS 1.1 operating system provides a 128-character type-ahead buffer so that keystrokes won't be lost if you continue to type while the system is busy. This buffer may be emptied, or flushed, if the program running needs to wait for a particular keystroke.

One of the biggest complaints about the original Apple II concerned the close proximity of the Reset key to the rest of the keyboard. In the Apple III the Reset key has been positioned at the rear edge of the keyboard enclosure, thus avoiding the accidental resets encountered in early Apple IIs. Simultaneously pressing Control and Reset simulates a power-up and reboots the system from the main disk drive.

In addition to the normal keyboard functions, a number of special control features are built into the Apple III keyboard. Pressing the Control key and one of the keys on the numeric pad will allow you to turn the video on and off, flush the type-ahead buffer, suspend screen output so that the processor can run at maximum speed, display control characters, or turn off the screen until the program requests an input.

In general, I found the keyboard versatile and pleasant to use. (Although the keyboard is actually part of the main enclosure, it is styled to appear as a separate unit. A convenient recess at the top can support a book or a pencil.) My only problem was that the very light touch required to avoid automatic key repeat sometimes caused me to produce extra characters. You have to break the habit of letting your hands rest on the keyboard while thinking about what to type next.

# C FOR CP/M-86

- CC-86 Compiler available for both CP/M-86\* and MP/M-86\* (incl. IBM PC)
- Full Unix\*\* V7 language compatibility
- Standard I/O library supports both buffered and non-buffered I/O and OS calls
- Stand-alone assembler supports relocatable code, local symbols and linkage to external modules
- Introductory prices: \$500 for CC-86 and assembler/linker; \$200 for assembler/linker; \$50 for manual (incl. K & R)

\* CP/M and MP/M are trademarks of Digital Research  
 \*\* Unix is a trademark of Bell Laboratories

 (503) 297-7153  
**Control-C Software, Inc.**  
 6441 SW Canyon Court  
 Portland, OR 97221



# "TI's Home Computer. This is the one."

A lot of computers offer a lot. Only one in its price range offers the most. The TI Home Computer.

**Better to begin with.** Anyone can start right away with our Solid State Software™ Command Cartridges. Dozens of programs are available in home management, education and entertainment.

**Easy to expand.** Our Peripheral Expansion System gives you plug-in cards for memory expansion, P-Code capabilities, a disk drive controller and the RS232 Interface. You can also add a modem, speech

synthesizer, disk drive and 80 column dot matrix printer.

**Programming flexibility.** TI BASIC is built into the Home Computer. But it can also handle TI Extended BASIC, UCSD Pascal® Version IV.0, TI LOGO II, TMS 9900 Assembly Language and TI PILOT. Programs can be stored in the optional Mini Memory Command Cartridge.

**High-Tech specs.** 16-bit microprocessor, 16K bytes RAM (expandable to 52K), 26K bytes internal ROM, up to 30K bytes external ROM. 3 simultaneous tones from

110 HZ to 40,000 HZ. High resolution video. U. & l.c. Single line overlay for 2nd function. Control & function keys. 16 color graphics with 4 modes & sprites.

Sound impressive? Compare a TI Home Computer with the competition and really be impressed. You won't even need a computer to tell you this is the one.



## TEXAS INSTRUMENTS

© 1982 Texas Instruments

\*UCSD Pascal is a trademark of the Regents of the University of California

Circle 461 on Inquiry card.

Mode	Format	Colors
0	24 by 40	black and white
1	24 by 40	16 foreground and 16 background colors
2	24 by 80	black and white

Table 2: Apple III text display modes, screen formats, and color capabilities.

Color	Color Value	ASCII Character	Gray Level
black	0	0	black
magenta	1	1	
dark blue	2	2	
lavender	3	3	
dark green	4	4	dark gray
gray	5	5	
medium blue	6	6	
light blue	7	7	
brown	8	8	medium gray
orange	9	9	
gray 2	10	:	
pink	11	:	
green	12	<	light gray
yellow	13	=	
aqua	14	>	
white	15	?	white

Table 3: Table of graphics colors or gray levels produced by the GRAFIX driver routine. After opening the routine as an output device, colors may be selected by printing a CHR\$(9) followed by an ASCII character. The color values shown are extracted from the lower four bits of the ASCII code transmitted. Higher-level graphics functions are provided by the BGRAF invocable module.

## Display Modes

The Apple III offers several text and graphics display modes. Either type of display is available in black and white or color, and both offer various formats and resolutions.

The normal text display is black and white, with a 24-row by 80-column format and a maximum of 1920 displayed characters. Alternate modes include 24 by 40 black and white and 24 by 40 color. In all three text modes the characters are normally displayed as a 5- by 7-dot matrix within a 7- by 8-dot character cell. However, all 128 characters are user-programmable and may be defined to be 7 dots wide by 8 dots high so that adjacent characters will touch in all directions if desired. (See table 2 for available text display modes.)

In the 40-column color-text mode, you can display 16 colors of characters on 16 colors of background. In combination with the user-definable character set, you can produce some surprisingly good color-graphics displays. For example, Apple's well-known "running-horse" demonstration program (shown in photo 6) is produced in color-text mode. The color values shown in table 3, although specified for graphics, can also be used for color text.

With four graphics modes, the Apple III's capabilities are significant-

## Expand your IBM PC...

### 256K IBM PC RAM EXPANSION BOARD

Model No. ADS 5001  
with parity upgraded  
at 64K intervals

#### SUGGESTED LIST PRICE

- W/64K RAM ... \$380.00
- W/128K RAM ... 655.00
- W/192K RAM ... 795.00
- W/256K RAM ... 995.00

Distributor and dealer inquiries welcome

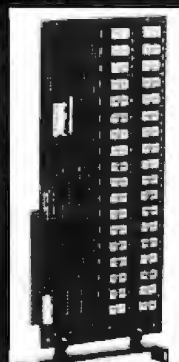

### ADS 8001 DOT MATRIX PRINTER

#### PRINT FEATURES

Print Speed: 120 CPS

Characters: 8 sizes, 5 different alphabets, upper/lower case descenders

Print Width: 8 in. max., Form Width: 4.5 in. to 10 in.

Print Mode: 9x9 exceptional quality with proportional spacing

Graphics: 144x144 dots/in. square and block graphic in ROMs

Print Head: 9 pins, heavy duty designed with air-cooled fins

Number of Columns: 136 max.

Print Direction: Bidirectional logic seeking

Form: Folded/Single sheet

Form Feed: Tractor and friction, bidirectional

Number of Copies: Original plus 3

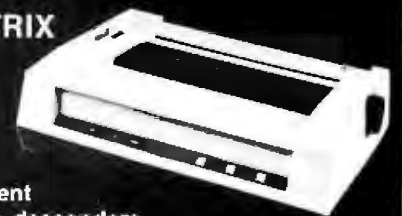

UL Listed

**ADS** ANTEX DATA SYSTEMS  
A Division of International Antex, Inc.  
2630 California Street, Mountain View, California 94040  
(415) 941-7914 TWX 910-373-8500 "INTERAX PTY"

# Go from spread sheets to letters in one easy move with a new double-duty DMS-5000.



Add the versatility of the DMS-5000's rotating screen—plus graphics—to HiNet™, the complete hardware/software local area network. It's flexible,

inexpensive, fast—and from a single source.

The DMS-5000 puts an end to scrolling left or right for spread sheets; up or down for full page, word processing display. Display 80 high-resolution characters by 66 lines or, rotate the screen 90° to horizontal and display an extended line of 132 characters by 50 lines (or 80 characters by 26 lines).

In either position, the DMS-5000 provides impressive graphics. Its 16 bit-mapped pixel intensities and an optional second memory plane, provide text overlays on a graphics display plus computerized "slide shows."

The DMS-5000 is a complete HiNet station too—with a Z80A and 64K RAM, or 8086 and up to 1MB RAM, each with full I/O complement and the HiNet network port.

Find out how the HiNet Local Area Network speeds business communications—and how the DMS-5000 doubles the potential of your HiNet hardware.



**Digital Microsystems** ™  
*Because man was not meant to work alone.*

1840 Embarcadero, Oakland, CA 94606 (415) 532-3686, TWX 910-366-7310/Extel House, East Harding St., London EC4P-4HB 01-353-1080 Telex 23721

CP/M® is a registered trademark of Digital Research, Inc.

Circle 182 on inquiry card.

BYTE September 1982 105

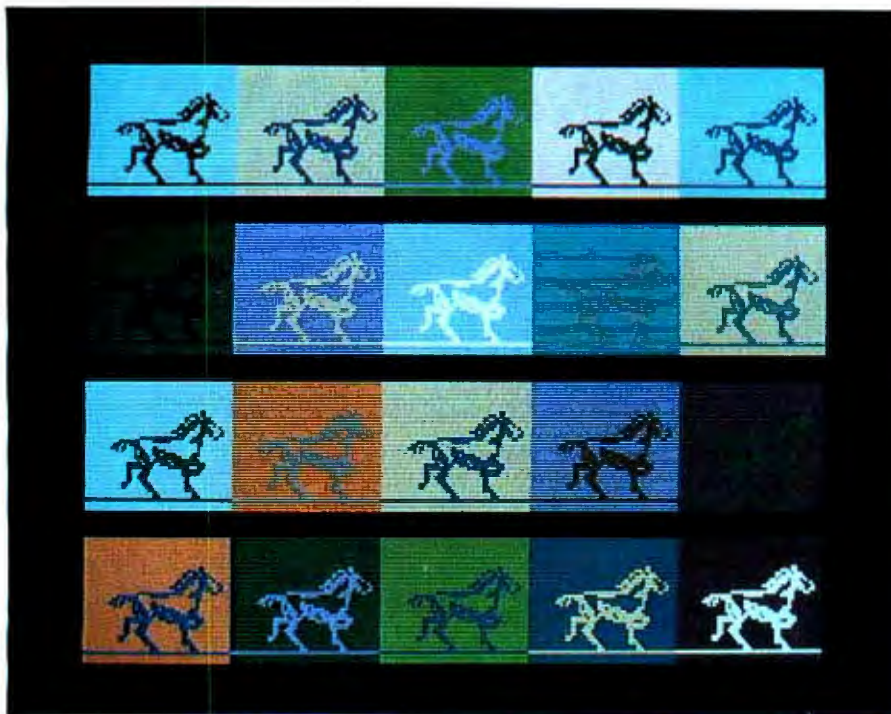

**Photo 6:** The well-known "running horse" demonstration. This display was generated using the 24-row by 80-column color-text display mode using the Apple III's programmable character set to produce the special shapes required.

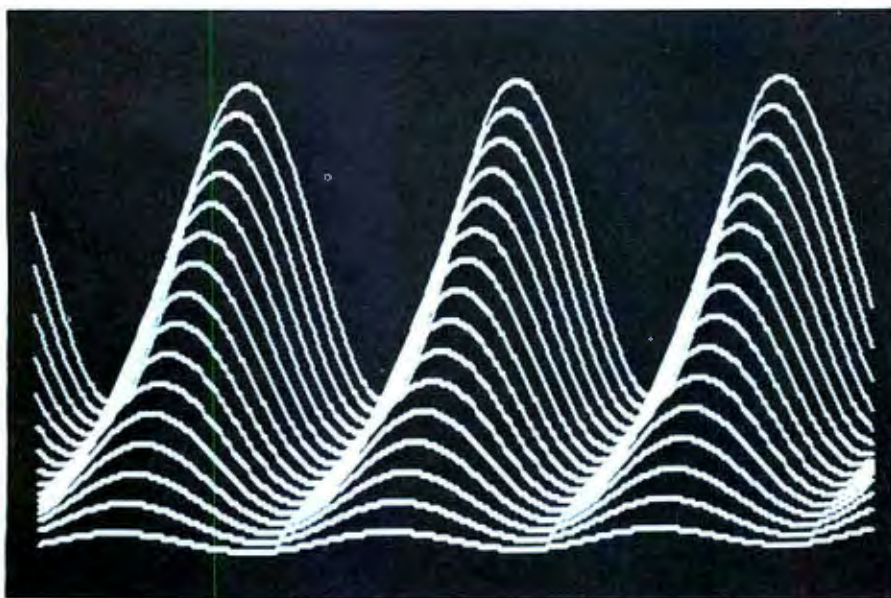

**Photo 7:** An example of the 560- by 192-pixel graphics display mode. Although this mode doesn't offer color, it is ideal for displays that require fine detail.

ly better than those of the Apple II (table 4 shows the available modes). The highest resolution offered is 560 by 192 pixels, black and white. This mode is useful for scientific or technical displays that require maximum resolution, as shown in photo 7. There is also a 280 by 192 black-and-white display mode.

The highest-resolution color display available is 280 by 192 pixels. Using this mode you can display up to 16 colors with some limitations. In each 7-dot-wide section of a given vertical coordinate, only two colors can be displayed. Bits that are turned on will display the specified foreground color, while bits that are

turned off display the background color for that section. This is usually noticed only when lines of different colors cross. The limited color mode is useful for many applications where 16 colors are required but where maximum resolution is needed (an example is shown in photo 8).

The most colorful graphics mode is the 140- by 192-pixel 16-color mode. With no limitations on color placement, it is capable of producing very impressive displays (see photo 9). One of the more interesting techniques in this mode mixes various colors of dots to produce a variety of in-between shades of color. Using this technique, it is possible to produce several hundred colors on an Apple III.

Although the resolution is effectively reduced in the shaded areas, this method is typically used for filling in areas of pictures rather than for outlines, which are normally drawn in solid color. A talented artist with a digitizing tablet and the appropriate software can produce results like those shown in photo 10.

### Apple SOS

Apple's SOS (Sophisticated Operating System) 1.1 is one of the more powerful operating systems available for an 8-bit microcomputer and offers features usually found only on larger machines. SOS supports multiple nested directories, handles interrupt-driven and DMA I/O, and manages the Apple III memory and hardware environment.

A unique feature of SOS is that there is no user interface. All communications with SOS are handled by the resident language (BASIC or Pascal for now) in a fashion compatible with the language syntax. For example, with Business BASIC you display a disk directory by typing CATALOG (or CAT), but in Pascal you would press F to enter the filter and then press E to get an extended directory. Rumor has it that Apple is working on a separate SOS user-interface package. This would allow access to SOS without requiring that a language be loaded into the system.

All Apple III I/O is handled by SOS through device drivers. Each

# CASH FLOW PROBLEMS?



## IT'S NICE TO KNOW SOMEONE WHO HAS THE SOLUTION.



MicroAge is your Solution Store . . . that means at MicroAge Computer Stores we have a wide selection of time-saving computerized business systems designed specifically to solve the daily cash flow problems every businessman faces.

MicroAge has computerized business systems that

quickly and affordably allow you to regain control of your critical accounts receivable . . . at last making it possible for you to carry out effective collection procedures on a consistent basis. MicroAge has accounts receivable program packages to automatically display and update account information; prepare trial balance including a balance-due and delinquency aging

report, and take care of dozens of other tasks that eat into your time and profit!

Computerized business systems from the MicroAge Computer Store are available in the \$5,000 to \$15,000 range, to suit the individual budget of your small business or professional practice. MicroAge backs up every system with personalized service, warranty service and repair, installation, systems consulting, even customer training. Visit the MicroAge Computer Store in your area soon with your business problems, and let us help you with the solution.

**MicroAge**  
**COMPUTER STORE**

*"The Solution Store" SM*

#### VISIT THE STORE IN YOUR AREA:

El Paso, Texas  
(915) 591-3349

Tucson, Arizona  
(602) 790-8959

Albuquerque, New Mexico  
(505) 883-0955

Pleasant Hill, California  
(415) 680-1489

Aurora, Colorado  
(303) 696-6950

Rochester, New York  
(716) 244-9000

Hurst, Texas  
(817) 284-3413

Salina, Kansas  
(913) 823-7596

Orland Park, Illinois  
(312) 349-8080

Milwaukee, Wisconsin  
(414) 257-1100

Mountain View, California  
(415) 964-7063

Scottsdale, Arizona  
(602) 941-8794

Anchorage, Alaska  
(907) 279-6688

San Diego, California  
(714) 278-0623

Richardson, Texas  
(214) 234-5955

Minneapolis, Minnesota  
(612) 338-1777

Omaha, Nebraska  
(402) 339-7441

Phoenix, Arizona  
(602) 265-0065

Columbus, Ohio  
(614) 868-1550

Indianapolis, Indiana  
(317) 849-5161

Portland, Oregon  
(503) 256-4713

Norwalk, Connecticut  
(203) 846-0851

St. Louis, Missouri  
(314) 567-7644

Oklahoma City, Oklahoma  
(405) 728-1837

Houston, Texas  
(713) 440-7547

W. Palm Beach, Florida  
(305) 683-5779

Toronto, Canada  
(416) 487-5551

Houston, Texas  
(713) 270-9647

Wilmington, Delaware  
(302) 658-3884

Allentown, Pennsylvania  
(215) 434-4301

**FOR FRANCHISE OPPORTUNITY INFORMATION CALL (602) 968-3168**

Graphics Mode		Graphics Resolution	Colors Available	Memory Used
Main Screen	Alternate Screen			
0	4	280h by 192v	black and white	8K
1	5	280h by 192v	16 colors with limitations	16K
2	6	560h by 192v	black and white	16K
3	7	140h by 192v	16 colors, no limitations	16K

**Table 4:** The Apple III graphics modes, resolution, available colors, and graphics screen memory requirements. Each main mode allows two separate screen buffers so that one screen may be updated while the other screen is displayed. When the black-and-white gray-scale video output is used, the 16 colors are output as 16 gray levels from black to white.

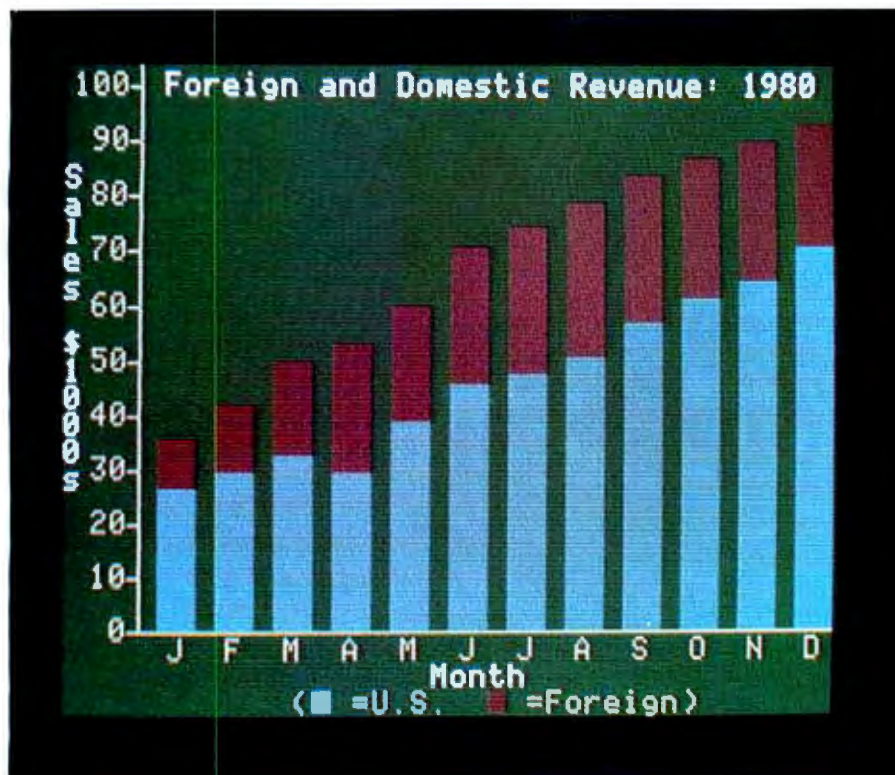

**Photo 8:** An example of the Apple III's 280- by 192-pixel limited 16-color mode. While there are some limitations on the combinations of colors that can be displayed next to each other, this mode offers the highest color resolution and is useful in many applications.

device driver is a group of routines designed to communicate with a particular hardware device and provide a uniform interface to SOS. For example, in a minimal Apple III system, you need the device driver .CONSOLE to handle the keyboard and text display, as well as .FMTD1 to handle the system floppy disk. Some of the other drivers included with the system are .AUDIO, .RS232,

.PRINTER, and .GRAFIX. Even though the RS-232C interface and the graphics display hardware are included in the Apple III, they are considered optional I/O devices for programming purposes.

The System Configuration Program (SCP) provides a variety of tools that allow you to modify and reconfigure the system device drivers. Once the device drivers are specified,

the SCP can regenerate a version of the system that meets your particular requirements. You can also use the SCP to specify whether a driver will be active or inactive. When the system is booted up, only the active drivers in the SOS.DRIVERS file will be loaded and require memory space.

From the programmer's point of view, device drivers are treated as files and can be used from either BASIC or Pascal. With Business BASIC they may be opened, accessed, and closed like any other file. (You can pass commands and data to an opened driver simply by using the PRINT# statement.) For example, the following Business BASIC lines would list the current program on the Silentype printer if the .SILENTYPE driver were installed:

```
10 OPEN#1, ".SILENTYPE"
20 OUTPUT#1
30 LIST
40 CLOSE#1
```

SOS allows the disk drives to be accessed either by their device name (e.g., D1) or by the volume name of the disk currently in the drive (e.g., MYDISK). Suppose that line 10 from the previous example were changed to read:

```
10 OPEN#1, "MYDISK/LISTFILE"
```

This would cause the program listing to be sent to a file called LISTFILE on a disk called MYDISK.

Unlike most systems which provide a single disk directory, SOS treats a directory like any other file. You can create and maintain directories easily with the same commands (LOCK, UNLOCK, RENAME, DELETE, etc.) that are used to maintain other files. You can assign any type of file to a directory, and any given directory may be a file assigned to another, higher-level directory.

The key to dealing with these nested levels of directories is the SOS pathname. Using device and file names separated by slashes, you can tell SOS what path to follow through various levels of directories. For example, the pathname /MYDISK/RECORDS/CHECKS/JAN.81/ would search the system for a disk volume



# GREAT IDEAS... Down to Earth Products

HARDWARE  
SOFTWARE



**SIERRA DATA SCIENCES**

(AVAILABLE SOON)

**SDS-S100 CHASSIS**  
6 Slot Motherboard  
Complete power supply  
Utilize regular or Thinline drive



**SDS-MULTIPLEXER/DISPLAY**

Three RS232C 1 to 2 Switches  
Two Seven Segment Status Display  
(Can be used as a line monitor for data communications link)  
(route RS232 to one of two devices)



**NEC-FLOPPY DISK DRIVE**

Double Sided  
Single Density/Double Density  
Up to 2.4 Megabyte  
**SPECIAL PRICING**



**SDS-HARD DISK INTERFACE**

Micropolis 1220 Series  
Interface Adapter

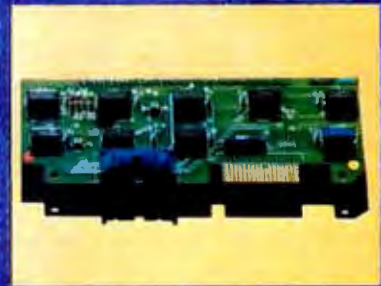

**SDS-SLAVE**

**SDS-ZSIO**

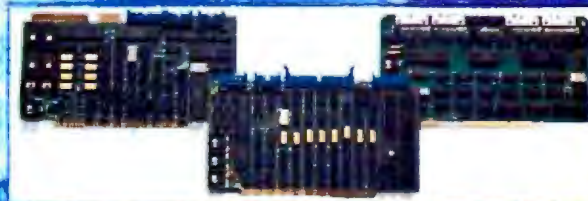

**SDS-SINGLE BOARD COMPUTERS**

Z80A CPU 64K Bank Switch Memory  
2 RS232 Channels 4 Timers IEEE 696 Buss Interface  
4 Parallel ports  
NEC 765 FDC with PLL to all Shugart compatible drives (SDS-Master only)

SDS-MASTER

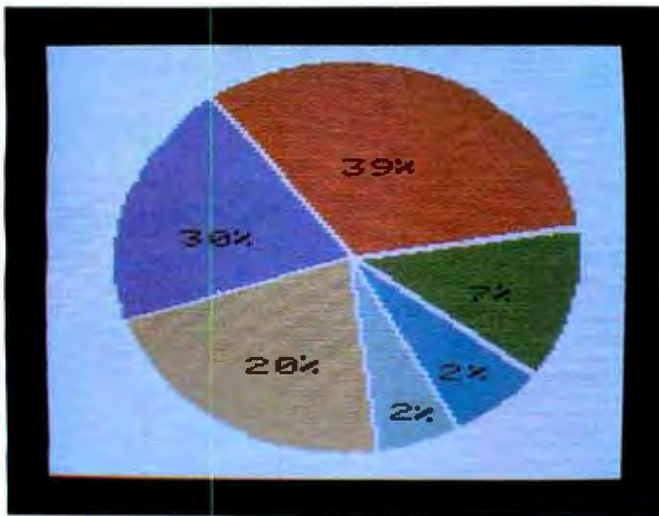

Photo 9: Two examples of the 140- by 192-pixel full 16-color mode.



Photo 10: A talented artist with a digitizing tablet and the appropriate software can produce results like this by using blended colors in the Apple III's 140- by 192-pixel color mode.

named MYDISK, locate the directory RECORDS (which itself would contain the subdirectory CHECKS), and then locate the file JAN.81. The pathname specifies the sequence of directories to follow when accessing a given file. As a convenience, SOS provides a pathname prefix facility. By using PREFIX\$ in the previous example, we could have set the pathname prefix to /MYDISK/RECORDS/ and then simply referred to CHECKS/JAN.81.

File types supported by SOS in-

clude DATA, which holds raw binary data; PASTXT (a Pascal text file); PASCODE (a machine language or Pascal program file); BASIC program files; ASCII files of unformatted text; PASDTA (Pascal data files); CAT or directory files; FONT files for the programmable character generator; and FOTO files, which store graphics screen images.

#### Business BASIC

Although it is fairly conventional, Apple's Business BASIC provides a

combination of advanced and unique features that makes it an easier language to use than Applesoft BASIC. With Business BASIC you should be able to write shorter programs with fewer errors. (See tables 5a-5e for a summary of the language.)

Business BASIC supports both TEXT and DATA files. The commands PRINT# and INPUT# are used to access text files while READ# and WRITE# allow you to store or read any type of data in a DATA file. All files may be sequential or random access (with the record size defined when the file is created). You can also use the word CREATE to make new files and directories. Directory entries may be examined by reading sequential text records from a directory file.

The language also provides formatted I/O. To output data to either the screen or a file, you can specify the format with an IMAGE statement or within the PRINT USING statement. The Apple III's output formats are very flexible. Numbers may be printed in fixed-point, floating-point, scientific, or engineering formats. You can also align the right or left edges of the output to a particular column or center the output if you wish.

Four main data types are available in Business BASIC. You can use integers ranging from -32,768 to +32,767, real numbers with 6-digit precision, long-integers with 64-bit binary precision, or strings that can vary from 0 to 255 characters. Arrays

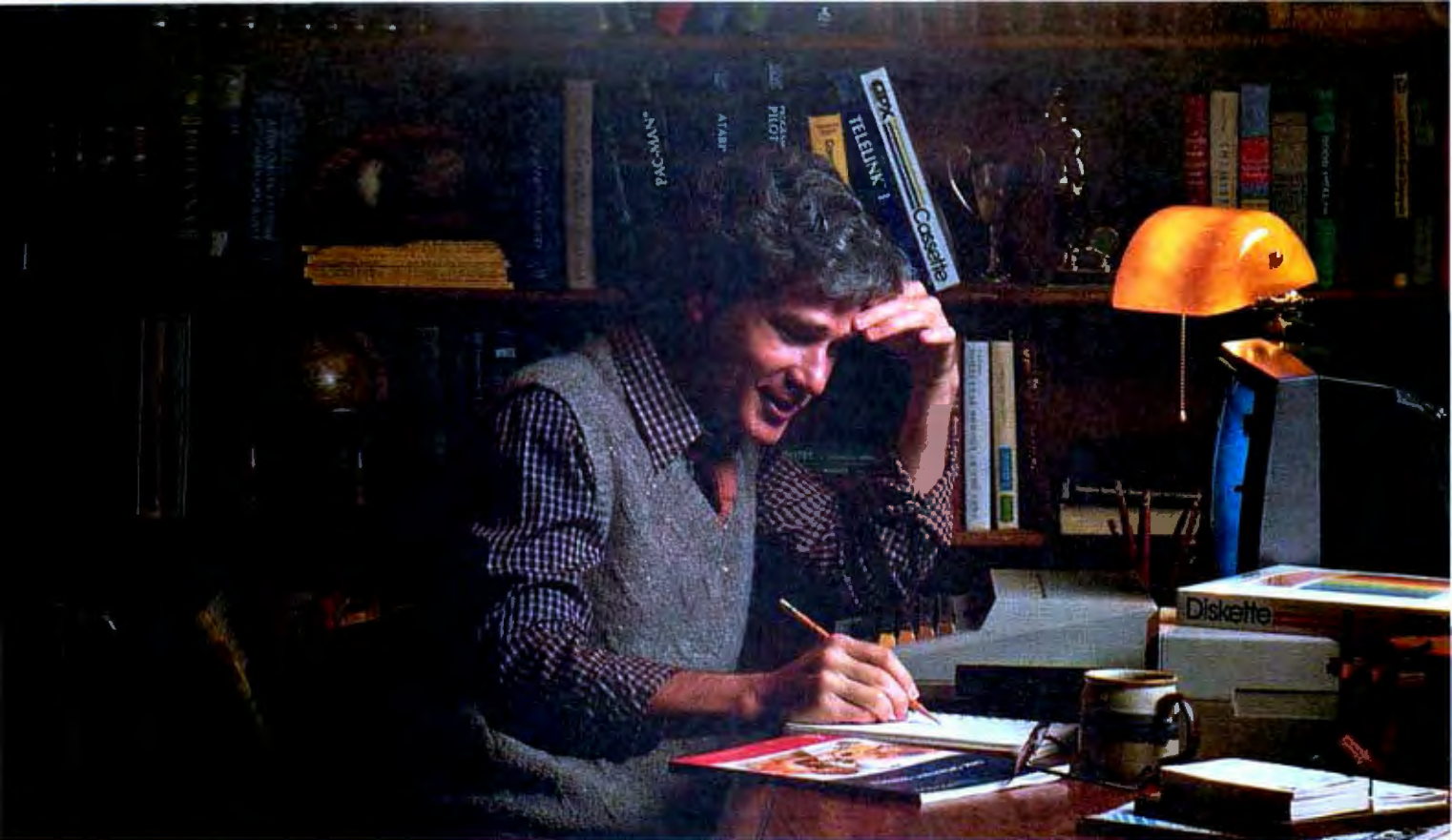

# MORE THAN EVER, ATARI HOME COMPUTERS ARE SPEAKING YOUR LANGUAGE.

With more program languages than ever to choose from, you now have more opportunities than ever to utilize the amazing capabilities of the ATARI 800™ Home Computer.

Whether you're a beginning programmer, or at the forefront of the art, you'll find an ATARI programming language that can make your task quicker and simpler than ever before. Just look at what ATARI has to offer:

**ATARI Microsoft BASIC**— Now we offer the industry standard, the most powerful Microsoft BASIC yet. With simple commands, it allows you to take advantage of unique ATARI hardware features such as our well-known player/missile graphics. For ease of programming, it includes n-dimensional arrays for numerics and string handling. And importantly, conversion procedures are simple.

**ATARI Macro Assembler**— Faster and more powerful than any ATARI language before, the ATARI Macro Assembler also allows you to access more memory space. And it's excellent for I/O interface and manipulation of such features as: player/missile graphics, sound registers and peripherals. In addition, the macro processor and "include" file library features speed-up program development considerably.

**Fig-FORTH\***— For specialized programming needs, such as educational or game applications, ATARI Fig-FORTH is uniquely effective. Fig-FORTH combines power and simplicity in an efficient 10K size, with characteristics of an interpreter and the speed of machine language code.

**ATARI BASIC**— An affordable and easy to use BASIC that requires only 8K of memory. It allows you to take advantage of the spectacular ATARI graphics and sound capabilities.

And its immediate mode error messages greatly simplify debugging.

**ATARI Assembler Editor**— An excellent tool to assist the assembler-programmer in creating, editing and debugging assembly programs.

**PILOT**— ATARI PILOT is an exceptional learning language, with built-in "turtle" graphics to let you create spectacular designs and pictures with very short programs. Simple one or two-letter commands allow you to create a dialogue with the computer. And a single "match" command can perform complex text evaluation and pattern-matching instantly.

**ATARI Pascal\***— An excellent high-level language for teaching structured programming, and for developing and maintaining programs. In addition to offering all the features of the ISO Pascal standard, ATARI Pascal offers unique extensions that allow you to take advantage of ATARI graphics and sound capabilities.

ATARI is constantly developing new ways to help you get more out of your ATARI 800 Home Computer. So watch for more innovative and exciting programming languages from ATARI in the future.

For more information, write to ATARI, Inc., Dept. C1Z, P.O. Box 16525, Denver, CO 80216.

© 1982 ATARI, Inc. All Rights Reserved  
\*Available from the ATARI Program Exchange



## ATARI HOME COMPUTERS

We've Brought The Computer Age Home.™

Command	Description
CATALOG	lists a disk directory
CHAIN	executes a program from disk leaving variables intact
CLEAR	clears program variables
CONT	continues interrupted program
CREATE	creates a new file or directory on disk
DEL	deletes a specified range of BASIC lines
DELETE	deletes a file from disk
HOME	clears current text window and places cursor in upper left-hand corner
INVERSE	sets further text output to inverse video characters
LIST	lists BASIC lines
LOAD	loads a BASIC program
LOCK	protects a file from alterations
NEW	clears a program and variables from memory
NORMAL	sets further text output to noninverse video
NOTRACE	turns off trace option
UNLOCK	removes protection from a disk file
RENAME	changes name of file on disk
RUN	loads and runs programs from disk or runs current program
SAVE	saves current program on disk
TEXT	sets screen to text mode with full-screen window
TRACE	turns on trace option

Table 5a: A summary of Business BASIC commands.

without dimensional limits can be created out of all four data types. To convert between the various data types, Business BASIC provides the numeric functions CONV, CONV%, CONV&, and CONV\$, all of which will accept arguments of any type and will produce real, integer, long-integer, and string results, respectively.

An interesting feature of Business BASIC is its use of *reserved variables* to access and control certain system functions (see table 5f for a summary). Reserved variable names are used to hold error codes, the file record numbers, or the code for the last key pressed. Others may be used to hold or control the cursor position on the screen, set the listing FOR...NEXT loop indent level, control the listing line length, or set the SOS pathname prefix.

One of Business BASIC's most powerful features is its ability to use *invocable modules*. An invocable module is a file of external procedures and functions, written in assembly language or Pascal, that can act as an extension to the BASIC language once invoked (loaded into the system). The modules provide features that are sometimes necessary but were not built into the Business BASIC language. The modules include VOLUMES.INV, which is used to show which volumes and devices are present in the system; READ-CRT.INV, which is used to read characters from the video display; DOWNLOAD.INV, which is used to load special text fonts into the Apple III's character generator; and RE-NUMBER.INV, which provides a variety of functions including program renumber, append, and merge. Another more significant module is BGRAF.INV which provides all the graphics procedures and functions used by Business BASIC.

Once a module has been invoked, the external procedures and functions provided in that file are accessed by using the BASIC commands PERFORM and EXFN. For example, the line

```
PERFORM PENCOLOR(%BLUE)
```

would execute the procedure to set

Statement	Description
CLOSE	closes all open files
CLOSE#	closes a particular file
DATA	standard DATA statements
DEFD FN	user-defined function
DIM	dimensions arrays
END	ends program
FOR...NEXT	standard FOR loop
GET	reads a single character from the keyboard or an EXEC text file
GOSUB	executes a subroutine
GOTO	continues execution at a specified line
IF...GOTO...ELSE	modified IF statement
IF...THEN...ELSE	standard IF statement
IMAGE	defines a PRINT USING format
INPUT	reads data from the keyboard
INPUT#	reads text from a disk file or other open device
INVOKE	loads an external file module of assembly-language routines
ON EOF#	sets up end-of-file error trap
OFF EOF#	turns off end-of-file error trap
ON ERR	sets up general error trapping
OFF ERR	turns off general error trapping
ON KBD	sets up keyboard interrupt handling
OFF KBD	turns off keyboard interrupt handling
ON GOSUB	standard computed GOSUB statement
ON GOTO	standard computed GOTO statement
OPEN#...AS	opens a file as INPUT, OUTPUT, or EXTENSION
OUTPUT#	sends subsequent output to file
PERFORM	executes a previously invoked routine
POP	removes one level of subroutine nesting
PRINT	prints to current output device or file
PRINT USING	prints using a given format

Table 5b: A summary of Business BASIC statements.

Table 5b continued on page 114

# FDC-I SBC-I SYSTEMASTER®

## The Next Logical Step

### Teletek FDC-I, The First Step

A CPU, floppy disc controller and I/O all on one board. Until SYSTEMASTER® the most powerful IEEE-S-100 board on the market.

### Teletek SBC-I, The Second Step

A board designed for use in high performance, multiprocessing systems. SBC-I combines its own CPU, serial and parallel ports, 128K of segmented memory and FIFO.

### SYSTEMASTER®, The Next Logical Step

Teletek's newest product — a breakthrough in S-100 board design. SYSTEMASTER® is a complete system. No other boards are required. It doesn't even require a bus!

But, when used with an S-100 bus, SYSTEMASTER® has even more capabilities. You can readily expand to multi-user or multi-processor systems using SYSTEMASTER® as the master board.

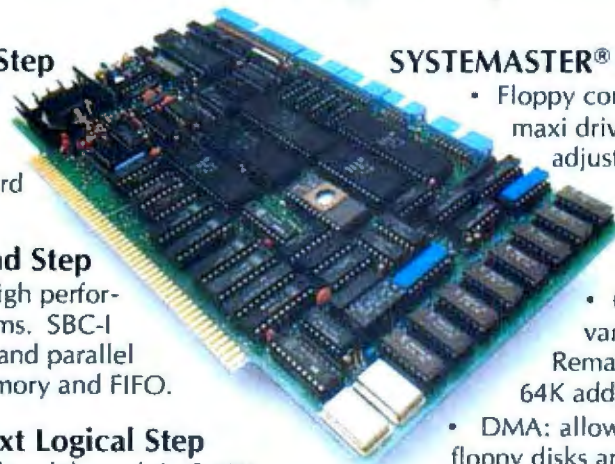

### SYSTEMASTER® Features:

- Floppy controller: controls mini and/or maxi drives; variable independently-adjustable pre-write compensation.
- CPU: 4MHz Z80A
- Two RS-232C ports.
- Two full parallel ports.
- 64K bank-selectable memory variable from 32K to 60K. Remaining memory is fixed at top of 64K address space.
- DMA: allows transparent data transfer to floppy disks and other devices without CPU wait states.
- Relocatable EPROM/ROM/PROM: 2K, 4K or 8K with deselect capability.
- Real-time clock.
- Operating systems available: Digital Research or Turbodos.
- Parallel ports may be connected to Teletek's PSC board for RS-422 capability.

# TELETEK

9767F Business Park Drive Sacramento, CA 95827 (916) 361-1777

Circle 457 on Inquiry card.

Table 5b continued:

Statement	Description
PRINT#	prints to a particular output device or file
PRINT# USING	prints to a particular file or device using a given format
READ	reads information from DATA statements
READ#	reads information from a data file
REM	standard remark statement
RESTORE	resets read pointer to start of DATA list
RESUME	returns from an ON ERR statement
RETURN	returns from a subroutine, ON KBD or ON EOF routine
SCALE	adjusts PRINT USING decimal-point position
SPC	used in PRINT statements to output numbers of blanks
STOP	stops program execution
SWAP	swaps the values of two given variables
TAB	used in PRINT statements to position the cursor to a particular column
WINDOW	sets the text/scroll window size and position
WRITE#	writes information to a data file

Function	Description
ABS	absolute value
ASC	converts ASCII character to its numeric value
ATAN	arc tangent
BUTTON	paddle-button state
CHR\$	converts number to equivalent ASCII character
CONV	evaluates expression—returns real number value
CONV\$	evaluates expression—returns string value
CONV&	evaluates expression—returns long-integer value
CONV%	evaluates expression—returns integer value
COS	cosine
EXFN	executes an invoked external function that returns a real number value
EXFN%	executes an invoked external function that returns an integer value
EXP	exponential, base e
HEX\$	returns a string that represents the hexadecimal value of the expression
INSTR	searches a string for a substring and returns location of occurrence
INT	largest integer less than or equal to argument
LEFT\$	takes substring starting with first character
LEN	length of a string
LOG	natural logarithm
MID\$	extracts a substring from a given string
PDL	returns a game-paddle position
REC	returns current file record number
RIGHT\$	takes substring ending with last character
RND	random number
SGN	sign of argument
SIN	sine
SQR	square root
STR\$	converts a number to a string
SUB\$	inserts a substring into a given string
TAN	tangent
TEN	converts last four characters of a string from a hexadecimal text image to a decimal value
TYP	returns the data type of a file record
VAL	converts a string to a numeric value

Table 5c: A summary of Business BASIC functions.

the graphic drawing color to blue, provided that the variable BLUE has previously been defined properly.

While external procedures may be passed only integer values, external functions can return either integer or floating-point numbers. The reserved word EXFN% is used to call functions that return integers and EXFN accesses functions that return real values.

## BASIC Graphics

Although you could use graphics from BASIC by simply opening the .GRAFIX driver and sending characters directly to it, the BGRAF.INV module provides a much cleaner and more powerful interface. It essentially adds a number of graphics commands to the Business BASIC language. (A similar library unit is included with Apple III Pascal.) The .GRAFIX driver must still be present and opened because you need a controller for the graphics hardware, but all graphics operations are performed by the external procedures and functions provided by BGRAF. The following two lines provide all the setup required:

```
100 OPEN#1, ".GRAFIX"
110 INVOKE "BGRAF.INV"
```

BGRAF provides all of the standard graphics operations. You can set PENCOLOR and the background FILLCOLOR, plot dots at absolute or relative positions with DOTAT and DOTREL, draw lines to absolute or relative points with LINETO and LINEREL, and position the graphics cursor with MOVETO and MOVE-REL. BGRAF supports a graphics VIEWPORT that allows you to limit graphics drawing to a particular area of the display screen.

Text may be displayed with graphics by simply sending it to the opened .GRAFIX driver with a PRINT# statement. NEWFONT lets you redefine the graphics text font by specifying character form, height, and width. The SYSFONT command switches you back to the current text-mode display font.

Predefined images stored in integer arrays may be displayed with DRAW-IMAGE. A given array may hold a

# Give your system some NEC, and watch its performance soar.

NEC's crisp, clear, high-performance JC1202 RGB color monitor, an industry standard. Also available: the JC1201 composite video version.

NEC's classic green monitor, (JB1201), one of computing's performance legends. Non-glare screen, easy on the eye. And the checkbook.



The impressive new NEC dot matrix printer. Parallel interface, 100 cps, 2K buffer, pin or friction feed. Stunning performance and versatility in the hottest new peripheral of the year.

Peripherals from NEC can make almost any computer system better.

Owners of Apple®, Radio Shack®, Atari®, IBM®, and many other personal computers will find their equipment to be compatible with NEC's famous monitors, as well as our highly-featured new PC-8023A dot matrix printer. (Some configurations may require a different interface.)

Ask your dealer for a demonstration.

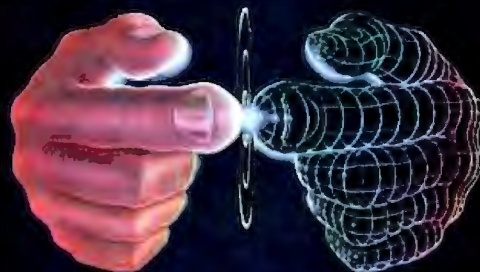

**Productivity  
at your fingertips**

**NEC**

**NEC Home Electronics (USA)  
Personal Computer Division**

1401 Estes Avenue  
Elk Grove Village, IL 60007

**YOUR PROGRAM HERE**







# The best software for the IBM Personal Computer. Could it be yours?

Attention, all programmers. Here's a chance to reach the top.

If you've written software that's completed and runs on the IBM Personal Computer, we could be interested in publishing it.

(We also could be interested if it runs on *another* computer. If we select your software, we'll ask you to adapt it to our system.)

But be advised.

Our expectations are great.

Because the software we publish must be good enough to complement IBM Personal Computer hardware. In fact, the more you take advantage of all our hardware capabilities (see the box at right), the more interested in your software we become.

Think about incorporating color graphics into your program, for example.

Use sound. Consider the power of our keyboard and remember to utilize the ten programmable function keys.

In all cases, we're interested in "friendly" software — with emphasis on quality and wide appeal. Programs with the greatest chance of being published must be easy to use, offer a better way to accomplish a task and provide something special to the user.

What kinds of programs? All kinds.

Education. Entertainment. Personal finance. Data management. Self improvement. Games. Communications. And yes, business.

We select programs that will make the IBM Personal Computer an even more useful tool for modern times.

IBM PERSONAL COMPUTER SPECIFICATIONS		
<b>User Memory</b> 16K-512K bytes*	<b>Display Screen</b> High-resolution* 80 characters x 25 lines Upper and lower case Green phosphor screen*	<b>Permanent Memory</b> (ROM) 40K bytes*
<b>Microprocessor</b> 16-bit, 8088*	<b>Auxiliary Memory</b> 2 optional internal diskette drives, 5¼", 160K bytes or 320K bytes per diskette	<b>Color/Graphics</b> <i>Text mode</i> 16 colors* 256 characters and symbols in ROM*
<b>Keyboard</b> 83 keys, 6 ft. cord, attaches to system unit*	<b>Operating Systems</b> DOS, UCSD-p System, CP/M-86†	<b>Graphics mode</b> 4-color resolution: 320h x 200v* Black & white resolution: 640h x 200v* Simultaneous graphics & text capability*
10 function keys* 10-key numeric pad Tactile feedback*	<b>Languages</b> BASIC, Pascal, FORTRAN, MACRO Assembler, COBOL	<b>Communications</b> RS-232-C interface Asynchronous (start/stop) protocol Up to 9600 bits per second
<b>Diagnostics</b> Power on self testing* Parity checking*	<b>Printer</b> Bidirectional* 80 characters/second 12 character styles, up to 132 characters/line* 9 x 9 character matrix*	
*ADVANCED FEATURES FOR PERSONAL COMPUTERS		

So, if you think your software is the best, consider submitting it. If it's accepted, we'll take care of the publishing, the marketing and the distribution. All you have to do is reap the benefits of our new royalty terms. And you're free to market your program elsewhere *at any time* even if you license it to us.

We're offering the ladder. Think about taking the first step.

For information on how to submit your program, write: IBM Personal Computer, External Submissions, Dept. 765 PC, Armonk, New York 10504.



## The IBM Personal Computer A tool for modern times

For an authorized IBM Personal Computer dealer near you (or information from IBM about quantity purchases) call 800-447-4700. In Illinois, 800-322-4400. In Alaska or Hawaii, 800-447-0890. †UCSD p-System is a trademark of the Regents of the University of California. CP/M-86 is a trademark of Digital Research, Inc.

Operators	Type
+ - * / DIV MOD	arithmetic
AND OR = < >	logical
>< <> <=	
=< >= =>	
NOT	unary logical
+	string concatenation

**Table 5d:** A summary of Business BASIC data operators. DIV and MOD apply only to the long-integer data type.

Data Type	Type Name	Range
16-bit integer	integer	- 32768 to 32767
64-bit integer	long-integer	$\pm 9223372036854775807 (\pm 2^{63} - 1)$
32-bit floating point	real	$\pm 10^{38}$ with 6 digit precision
character strings	string	0 - 255 characters
arrays	(all types)	no dimensional limits

**Table 5e:** A summary of Business BASIC data types and ranges.

Variable	Description
EOF	holds reference number of file causing an EOF error
ERR	holds error type code of most recent error
FRE	holds amount of remaining bytes of memory available
HPOS	holds/controls cursor horizontal position
INDENT	holds/controls number of spaces to indent FOR . . . NEXT loops in listings
KBD	holds the ASCII value of the last key pressed
OUTREC	holds/controls the maximum line length output by the LIST command
PREFIX\$	holds/sets current SOS pathname prefix
VPOS	holds/controls current cursor vertical position

**Table 5f:** A summary of Business BASIC reserved system variables.

Procedure	Description
DOTAT	plots a single dot at a given position
DOTREL	plots a dot relative to current position
DRAWIMAGE	draws a rectangular bit-map image at current position
FILLCOLOR	sets background color
FILLPORT	fills current VIEWPORT with FILLCOLOR
GLOAD	loads and displays a FOTO file from disk
GRAFIXMODE	specifies graphics mode and buffer choice
GRAFIXON	switches display to current graphics mode and buffer
GSAVE	saves current graphics display as a FOTO file on disk
INITGRAFIX	sets full-screen VIEWPORT, places cursor at upper left-hand corner and sets normal color and transfer tables
LINEREL	draws a line relative to current position
LINETO	draws a line from current to an absolute position
MOVEREL	positions cursor relative to current position
MOVETO	positions cursor at an absolute position
NEWFONT	used to specify a new graphics character font
PENCOLOR	sets current PLOT and DRAW color
RELEASE	frees highest graphics buffer memory
SETCTAB	sets a color-table entry
SYSFONT	causes normal system character set to be used as graphics character font
VIEWPORT	defines graphics-drawing window size and position
XFEROPTION	defines the logical operation that places dots on the screen
XLOC	returns graphics-cursor x position
XYCOLOR	returns color of dot on screen at current position
YLOC	returns graphics-cursor y position

**Table 5g:** A summary of Business BASIC graphics procedures.

number of images that can be selected with the DRAWIMAGE arguments.

One of the most interesting features of BGRAF is its control of color. By using two controllable processes—the color table and the transfer option—you can modify the effects of plotting and filling operations.

With 256 entries, the color table specifies which color results from plotting a dot of a given "source color" on top of a dot of a given "screen color." The color table is initialized to simply display the source color regardless of the existing color of the specified dot position. However, by altering the mapping conditions in the color table you can establish a color precedence. This precedence allows lines to appear to pass under or over existing images, or it can produce a number of other interesting effects.

To alter a color-table entry, you use the external function SETCTAB. The form of the statement would be:

```
SETCTAB (%SOURCECOLOR,
          %SCREENCOLOR,
          %RESULTCOLOR)
```

The following example would alter the color table so that when an orange dot was printed onto a blue background, the result would be green:

```
SETCTAB (%9, %6, %12)
```

Table 3 shows a summary of the graphics colors and their color values.

The black-and-white equivalent of the color table is the *transfer option*, which describes the logical operation used to place dots on the screen. De-

# SAVVY™



... the **PERSONAL LANGUAGE™** system  
that mirrors your commands using  
your own words!

## What SAVVY is—

- SAVVY is a miraculous new information handling system.
- SAVVY is an automatic database management system.
- SAVVY is a new level of machine intelligence.
- SAVVY, part hardware, part software, is the beginning of truly "Personal Computing".



Trademark: SAVVY, Robot Programmer: Excallbur Technologies Corporation.

Personal Language: SAVVY Marketing International.

## What SAVVY does—

Through SAVVY, you and your computer talk to each other in your own natural, conversational English (or Spanish, or French, etc.).

It learns from you what you want done in your own personal language. Once SAVVY learns your language it can create any file you wish. Input, output, additions, changes and deletions are arranged for you.

SAVVY's "Robot Programmer" has been trained to write 100% of the programs needed to manage your database information.

SAVVY runs on CP/M™ and Apple DOS.

## What YOU discover—

You'll discover that SAVVY recognizes your personal words, even if misspelled, or even if you use a phrase never used before!

SAVVY continues to grow through use to become better and better at understanding your commands.

Eventually, you will see SAVVY as a mirror to your own way of thinking and working. It is a re-definition of "user-friendly".

SAVVY, it's the first system that truly means "personal computing".

SAVVY is like no other system on earth.

SAVVY cost \$950.

Seeing is believing. SAVVY is on display at selected computer retail locations. Call for the name of your nearest dealer.

CP/M is a trademark of Digital Research Corp.

Apple is a Trademark of Apple Computer Inc.

100 South Ellsworth Street, 9th Floor, San Mateo, CA 94401 (415) 340-0335

# SAVVY

MARKETING INTERNATIONAL

pending upon the option specified, a dot (or its inverse) may replace existing data, overlay it, invert it, or erase it with new data. The XFEROPTION procedure and an argument specify the transfer mode. The transfer option may also be used with color data, but predicting the results is difficult.

Although circle drawing and turtle graphics are not supported, BGRAF is still a very nice package of routines that should allow you to produce a wide variety of color graphics. (See table 5g for a summary.)

### Business BASIC Performance

Although Business BASIC is much more powerful than the Apple II's Applesoft BASIC, it is not much faster. Tests with the series of sixteen benchmark programs shown in listing 1 indicated that while Business BASIC is faster than Applesoft in some areas, it is slower in others. The net result should be a slight to medium speed improvement, depend-

ing upon the program being run.

The best test in the series was probably the Sieve of Eratosthenes prime-number program used by Jim Gilbreath (see "A High-Level Language Benchmark," September 1981 BYTE, page 180). Although this program is more representative of average program execution than any of the other

---

## The execution speed advantage of the 6502B is largely cancelled out by the complexity of Business BASIC.

---

benchmarks, it uses only addition and subtraction and does not have a wide variety of BASIC statements. In this test, the Apple III proved to be slightly faster than the Apple II but slower than the IBM Personal Computer or the 4-MHz Z80.

From the results of this limited set of benchmarks, it seems that the execution speed advantage of the Apple III's 6502B is largely cancelled out by the increased complexity of Business BASIC. However, I suspect that in larger programs Business BASIC will turn out to be a good deal faster than Applesoft. The combination of its powerful built-in features and invocable modules will eliminate the code required in Applesoft to accomplish the same functions. Also, if the benchmark programs had included the appropriate code to turn off the video screen during time-critical calculations, an additional 30 percent speed increase could have been gained by allowing the 6502B to run at 2 MHz. This would have placed the Apple III ahead of the IBM and Z80 computers in many tests.

Although benchmarks always have some validity, they may or may not be significant in a given application. It is best to approach the results with caution—the programmer frequently

# What is Unique-NISS™?

**FREE CALL  
FREE CATALOGUE**

- 1** An unprecedented forecasting software support service that provides you with one-on-one interaction with our staff of professionals.
- 2** The leading forecasting software packages available today for the leading personal computers.

Maximize your personal productivity through the use of our forecasting software, a one-year service agreement, newsletters and prompt access via our toll-free hot lines.

Call us now and profit from the integration between you, the discerning end-user, and NISS, the unequalled direct support service.



NATIONAL INTEGRATED SOFTWARE SERVICES, INC.

**1-800-525-SOFT**

In Colorado (303) 694-1994

8800 East Arapahoe Road, Englewood, Colorado, 80112

BY 9/82

# SONICS DELIVERS:



## SD SYSTEMS.

SONICS MICRO SYSTEMS' PLEDGE TO THE CUSTOMER IS :

1. PROFESSIONAL TREATMENT
2. FULL TECHNICAL SUPPORT
3. ON-TIME DELIVERIES
4. COMPETITIVE PRICES

ORDER ENTRY, STATUS AND DELIVERY.

THAT'S OUR JOB!

TECHNICAL PROBLEM SOLVING.

THAT'S OUR JOB!

DELIVERY ON TIME, ON PRICE.

THAT'S OUR JOB!

THE BEST FOR LESS.

THAT'S OUR JOB!

**CAN YOU AFFORD NOT TO TRY OUR APPROACH?**

### BOARD LEVEL PRODUCTS

SBC 200 _____	\$308
EXPANDORAM II _____	\$417
EXPANDORAM III _____	\$799
VERSA FLOPPY II _____	\$355
VDB 8024 _____	\$465
MPC-4 _____	\$495
Z-80 STARTER KIT _____	\$299
MODEL 200 64K RAM	
SOFTWARE BANK SELECT _____	\$450



**SONICS**

**MICRO SYSTEMS INC.**

1500 N.W. 62ND STREET • SUITE 508

FT. LAUDERDALE, FL 33309 • 1-800-327-5567

IN FLA CALL 305-776-7177

Cientes Latinoamericanos serán atendidos por nuestro departamento internacional (en español), bajo la gerencia de la LCDA. Joan Voyles.

# PICK A DAISI

(Data Acquisition and Instrumentation Systems Interface)

## To automate your lab

Exciting new capabilities can blossom in your lab—when you automate it with the DAISI family of data acquisition peripherals for your Apple Computer.

DAISI Interfaces, from Interactive Structures, turn your economical Apple into a personal electronic lab assistant. DAISI products are designed to read instruments and sensors, control temperature and pressure . . . with reliability and precision.

Here's a rundown on some DAISI interfaces

### AI13, 12-Bit Analog Input System—\$550

■ 16 input channels ■ 20 microseconds conversion time.

### AI02, 8-Bit Analog Input System—\$299

■ 16 input channels ■ 70 microseconds conversion time.

### AO03, 8-Bit Analog Output System—\$195-\$437

■ up to 8 independent channels ■ range and offset adjustable.

### DI09, Digital Interface with Timers—\$330

■ timing and interrupt capability ■ direct connection to BCD digits, switches, relays.

Don't settle for garden variety equipment for your laboratory applications. Get the best—at a great price. Pick a DAISI!



Call us for the DAISI dealer near you.

**Interactive Structures Inc.**  
146 Montgomery Ave.  
Bala Cynwyd, PA 19004  
(215) 667-1713

All DAISI interfaces come complete with cable, instructional diskette and comprehensive manual.

**Listing 1:** Execution benchmark programs. See table 6 for a summary of their results.

**Listing 1a:** tests a null loop.

```
60  A=2.71828
80  B=3.14159
100  FOR I=1 TO 5000
320  NEXT I
```

**Listing 1b:** tests REM execution time.

```
100  FOR I=1 TO 5000
120  REM
140  REM
160  REM
180  REM
200  REM
210  REM
240  REM
260  REM
280  REM
300  REM
320  NEXT I
```

**Listing 1c:** tests the IF . . . THEN statement.

```
60  A=2.71828
80  B=3.14159
100  FOR I=1 TO 5000
120  IF A<B THEN 320
320  NEXT I
```

**Listing 1d:** tests addition.

```
60  A=2.71828
80  B=3.14159
100  FOR I=1 TO 5000
120  C=A+B
320  NEXT I
```

**Listing 1e:** tests multiplication.

```
60  A=2.71828
80  B=3.14159
100  FOR I=1 TO 5000
120  C=A*B
320  NEXT I
```

**Listing 1f:** tests division.

```
60  A=2.71828
80  B=3.14159
100  FOR I=1 TO 5000
120  C=A/B
320  NEXT I
```

**Listing 1g:** tests exponentiation.

```
60  A=2.71828
80  B=3.14159
100  FOR I=1 TO 5000
120  C=A^B
320  NEXT I
```

Listing 1 continued on page 124

# you have one apple... now get a whole bushel

of apple add-ons

from **Vista** COMPUTER  
COMPANY,  
INC.

Available through your  
local computer dealer.



## MODEL GB75<sup>®</sup> Typewriter Interface

Apple to IBM Electronic 50, 60, 75 Typewriters Interface ■ Reads IBM keyboard in parallel with Apple keyboard ■ Supports the IBM code functions using an escape sequence ■ Types at about 13 characters per second ■ Prints from Integer or Applesoft programs ■ Supports the "Control I Number N" parallel line length mode sequence ■ Has switch selectable upper/lower case I/O 60, 66, 78 continuous from feed page lengths, 40+video, 80, 95, 132 character line lengths

Suggested price \$225.00

## TIMECARD III<sup>®</sup>

Multi-function time utility for the APPLE III computer system. Contains the year of the century, the month, the date, the day of week, the hour, the minute, the second. ■ A countdown timer with a range of one millisecond to 999 hours, 59 minutes, 59 seconds, 999 milliseconds ■ Selectable 12 or 24 hour time formats ■ Diagnostic error reporting ■ Fully compatible with the APPLE SOS operating system

Suggested price \$195.00

Circle 418 for Dealers only Circle 419 for OEM's only Circle 420 for all other inquiries

## MODEL 150 TYPE AHEAD BUFFER

■ Up to 40 character type ahead capability ■ Enter commands or data while your Apple is processing previous instructions ■ Compatible with all Apple computers, keyboards and software ■ No cuts — no jumpers — no software patches required ■ Includes complete instructions for quick and easy installation

Suggested price \$49.95

## A800<sup>®</sup> FLOPPY DISK CONTROLLER

■ High speed DMA transfer of data (1 micro-second/byte) ■ Documentation provided — includes theory of operation, schematics and diskettes ■ Uses all standard Apple DOS commands (OPEN, CATALOG, LOCK, DELETE, LOAD, etc.) except for INIT which has been improved and enhanced in a Vista format routine ■ Compatible with Apple DOS 3.3, Pascal 1.1 and CP/M 2.2 (with the Z80 soft card by Microsoft) ■ 2K x 8 PROM contains Autoboot functions and all eight-inch

floppy driver code allowing complete compatibility with Apple DOS 3.3

Suggested price \$545.00

## PROM DEVELOPMENT SYSTEM<sup>®</sup>

■ Menu driven program development monitor ■ Programs 2708, 2716, 2532, 2732 and 48016 EPROMS ■ Simulates PROM from RAM 4K ■ Data and address interface for operator location and control ■ Complete user documentation

Suggested price \$495.00

## VISION 80

■ Full upper and lower case character with 3 dot descenders ■ 9x10 dot matrix per line U.S. (9x11 Europe) ■ 128 ASCII character set ■ BASIC, FORTRAN and Pascal languages supported ■ Z80™ and CP/M™ compatible ■ Compatible with all standard Apple™ peripherals

**Vista** COMPUTER  
COMPANY,  
INC.

Circle 481 on Inquiry card.

© Copyright 1981 Vista Computer Company, Inc.  
™ Apple Computer Company, Inc.

■ Shift and lock for upper and lower case ■ Source switches between 40x24 and 80x24 software and hardware ■ Rated #1 video card by Softalk and Call Apple

Suggested price \$325.00

## VISION 40

Softscreen programmable character/generator card for the Apple II computer ■ Allows use of DOS tool kit upper/lower case character sets in Apple 40 column mode ■ Permits creation of new alpha/numeric and graphic characters under Am-inatrix ■ Ideal for non-English language applications ■ Compatible with most popular word processing software packages

Suggested price \$175.00

## VISION 20

■ Cost effective ■ Compatible with the latest Apple II ■ Complete easy to follow installation guide ■ 120 day warranty ■ Immediate delivery

Suggested price \$29.95

1317 E. Edinger  
Santa Ana, CA 92705  
(714) 953-0523

™ Digital Research, Inc.  
® Designed by Burtronix

# MICROMAIL'S GOT IT!!

## LETTER QUALITY PRINTERS

### ★ DIABLO ★

• 630 RO  
• 40 CPS  
• SERIAL RS232C  
**\$1899.00**  
630 KSR ..... CALL

• 630 API-RO  
"INTRODUCTORY OFFER"  
**\$1649.00**  
"TAILORED TO YOUR SYSTEM"

• 620 RO  
"INTRODUCTORY OFFER"  
**\$1149.00**  
• 25 CPS  
• SERIAL RS232C

#### NEC

- 7700 SERIES
- 3500 SERIES

Call for Our LOW PRICES

#### QUME

"ON SITE WARRANTY"

- SPRINT 9/45
- SPRINT 9/55

Call for Our LOW PRICES

#### DEC

LA 34 DA ..... \$899.00  
"LA 120 REPLACEMENT"  
LA 12D .... NEW! .... \$1599.00  
VT100 ..... \$1399.00  
VT101 ..... CALL  
VT131 ..... \$1499.00

#### TELEVIDEO

910 ..... \$569.00  
912 ..... \$689.00  
920 ..... \$725.00  
950 ..... \$909.00  
925 ..... NEW! ..... CALL

**DEC LA 100**  
• DUAL MODE  
MATRIX PRINTER

★ **NEW** ★ **3M WHISPER WRITER**  
TWX / TELEX • TIME SHARE  
• COMPUTER TERMINAL

#### ANADEx

DP 9500/9501 ..... \$1125.00  
DP 8000 AP ..... \$749.00  
DP 9620A ..... NEW!  
6000 ..... NEW! ..... CALL

#### TEXAS INSTRUMENTS

810/2 ..... \$1249.00  
(includes upper/lower case option)  
810/2 VFC/CP ..... \$1399.00  
(includes u/l case forms  
control & compressed print)

"LABOR SAVER"  
**CUT SHEET FEEDERS**  
as low as  
**\$749.00**

**VT100 / TELEVIDEO**  
**GRAPHICS OPTION**  
AS LOW AS  
**\$999.00**

**CALL TOLL FREE (800) 854-6028**

SAVE ON  
PREPAID  
ORDERS

MASTERCARD  
VISA  
ACCEPTED

C.O.D.  
REQUIRES  
15% DEPOSIT

SHIPPING IS  
FREIGHT  
COLLECT

**WE SELL INTERNATIONALLY**

**MICROMAIL**

P.O. Box 3297  
Santa Ana, CA 92703  
Phone: 714/731-4338  
TWX: 910 595 1146

Listing 1 continued:

Listing 1h: tests transcendental functions.

```
80 A=2.71828
80 B=3.14159
100 FOR I=1 TO 5000
120 C=SIN(A)
320 NEXT I
```

Listing 1i: tests the LOG function.

```
80 A=2.71828
80 B=3.14159
100 FOR I=1 TO 5000
120 C=LOG(B)
320 NEXT I
```

Listing 1j: tests the ON. . .GOTO statement.

```
80 N=2
100 FOR I=1 TO 5000
120 ON N GOTO 80,320,100
320 NEXT I
```

Listing 1k: tests the GOSUB/RETURN statement.

```
80 A=2.71828
80 B=3.14159
100 FOR I=1 TO 5000
120 GOSUB 1000
320 NEXT I
1000 RETURN
```

Listing 1l: tests the INT (integer) function.

```
80 A=2.71828
80 B=3.14159
100 FOR I=1 TO 5000
120 C=INT(A)
320 NEXT I
```

Listing 1m: tests the MID\$ function.

```
80 A$="abcdefghijkln"
100 FOR I=1 TO 5000
120 B$=MID$(A$,6,6)
320 NEXT I
410 PRINT""
420 END
```

Listing 1n: tests random number speed.

```
80 A=2.71828
80 B=3.14159
100 FOR I=1 TO 5000
120 C=RND(1)
320 NEXT I
```

Listing 1o: tests the CHR\$ function.

```
80 A$="abcdefghijkln"
100 FOR I=1 TO 5000
120 C$=CHR$(50)
320 NEXT I
```

Listing 1 continued on page 126





# How to project your company's fortune without spending one

**Introducing the only complete graphics system available today.**

If you think that professional quality transparencies are too expensive and time consuming to produce for everyday use, it's time you discovered the Strobe Graphics System.

Because with the Strobe Graphics System and StrobeView™ Software Package, you can now create superb multicolor transparencies (as well as traditional hardcopy graphics) directly from your computer. And you can do a lot more, in less time, for a lot less money than with any other system made today.

It's a fact. The Strobe Graphics System contains everything you need to transform complex data into dynamic, colorful visuals: software, hardware, documentation, accessories. Transparencies that once took hours to produce are plotted within minutes. Information can be presented as bar charts, pie charts, flow charts or curves in a variety of colors. And all with a resolution and quality matched only by systems costing thousands of dollars more.

The new StrobeView composer package is the newest addition to Strobe's already

extensive library of easy to use, menu-driven software. StrobeView is a "scratch pad driven" program with a spatial memory feature for consistently positioning text and graphics in the same place on a page... use after use, edit after edit.

But that's just the beginning. With StrobeView, you can create a broad variety of linear flow charts, block diagrams and organizational charts. You can also choose among several preprogrammed symbols for emphasizing important figures. The system allows you to process and edit text, and will print boldface,

offset or regular type in a wide range of character sizes. And when you are finished with a transparency, you can alter, edit or save your text for future use.

When the Strobe Graphics System is interfaced to your computer, a projector screen can speak anyone's language—visually. Visit your local dealer and learn how to start projecting your fortunes today. Because a perspective on the present can also be your window to the future.

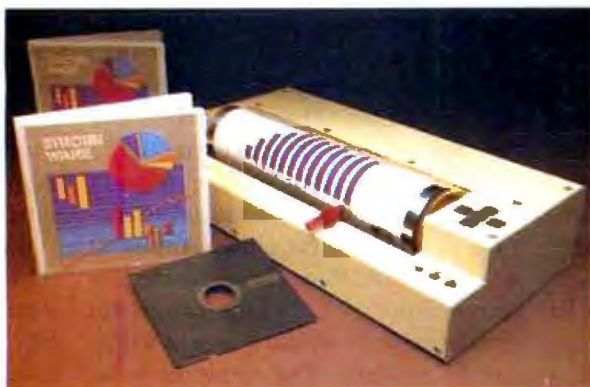

## The Strobe Graphics System



**Strobe Inc.**  
897-5A Independence Avenue  
Mountain View, CA 94043  
Telephone 415/969-5130

Listing 1 continued:

**Listing 1p:** Jim Gilbreath's Sieve of Eratosthenes prime-number program.

```

1  SIZE=7000
2  DIM FLAGS(7001)
3  PRINT"only 1 iteration"
4  COUNT=0
5  FOR I=1 TO SIZE
6    FLAGS(I)=1
7  NEXT I
8  FOR I=0 TO SIZE
9    IF FLAGS(I)=0 THEN 18
10   PRIME=I+I+3
11   K=I+PRIME
12   IF K>SIZE THEN 17
13   FLAGS(K)=0
14   K=K+PRIME
15   GOTO 13
16   COUNT=COUNT+1
17   NEXT I
18   PRINT COUNT,"Primes";""

```

**Listing 2:** Disk-access benchmark programs. Listings 2a and 2b are write and read tests for the Apple III. Similar programs were used for the Apple II and the IBM Personal Computer.

```

(2a) 40  A$="12345678123456781234567812345678"
      60  B$=A$+A$+A$+A$
      80  NR=500
      100 OPEN#1,"TEST"
      140 FOR I=1 TO NR
      160   INPUT#1;B$
      200   NEXT I
      220 CLOSE#1
      240 PRINT"DONE"

(2b) 40  A$="12345678123456781234567812345678"
      60  B$=A$+A$+A$+A$
      80  NR=500
      100 OPEN#1,"TEST"
      140 FOR I=1 TO NR
      160   PRINT#1;B$
      200   NEXT I
      220 CLOSE#1
      240 PRINT"DONE"

```

Listing #	Benchmark	Apple III Business BASIC	Apple II Applesoft BASIC	IBM Advanced BASIC	4-MHz Z80 MBASIC 4.51
1a	empty loop	8.9	6.7	6.43	5.81
1b	10 REMs	19.2	19.5	21.0	15.8
1c	IF...THEN	22.9	19.8	17.6	14.9
1d	addition	19.5	17.5	18.2	16.3
1e	multiplication	25.0	27.3	19.6	19.9
1f	division	27.6	28.8	23.8	24.9
1g	exponentiation	184.5	249.1	84.8	121.1
1h	sine(x)	98.0	193.1	73.9	63.1
1i	log(x)	87.1	113.6	49.4	55.4
1j	ON...GOTO	18.6	17.5	17.3	12.9
1k	GOSUB/RETURN	16.4	13.6	12.4	9.4
1l	INT(x)	20.0	19.3	18.1	15.5
1m	MID\$	37.3	32.5	23.0	18.6
1n	RND(x)	90.5	33.1	18.4	19.7
1o	CHR\$	26.8	23.5	16.2	13.4
1p	prime numbers	222.4	224.4	190.0	151.0

**Table 6:** Table of execution times (in seconds) for a series of benchmark tests run on Apple III Business BASIC, Apple II Applesoft BASIC, IBM Personal Computer Advanced BASIC, and a 4-MHz Z80 computer running Microsoft's MBASIC 4.51. The results shown may or may not be indicative of performance in a particular application; they should be interpreted with caution. The results for the IBM Personal Computer and the Z80 microcomputer were taken from Gregg Williams' "A Closer Look at the IBM Personal Computer" (January 1982 BYTE, page 54). See listing 1 for the benchmark programs used.

makes more difference than the machine. (The benchmark results are summarized in table 6.)

### Apple II Emulation

The Apple III's ability to emulate an Apple II is an extremely useful feature that allows access to the tremendous volume of Apple II software. Virtually all Apple II DOS 3.3 programs in either Applesoft or Integer BASIC can be run on the Apple III without change—the few exceptions are those programs that require a

RAM card or language system to operate. Also, some of the Apple II arcade games use their own routines to read the game paddles rather than calling the routines in the Apple II's monitor ROM. These programs will run but will not operate correctly.

To use the Apple II emulation mode, you must boot a special emulation disk and select either Applesoft or Integer BASIC as the available language. Since the Language Card is not emulated, only one language at a time can be resident. The Apple III serial

port can be configured to emulate either an Apple II serial card or a communications card. The data rates and carriage-return handling can also be specified. Once the emulation parameters are specified or the defaults accepted, you can boot a normal Apple II DOS 3.3 disk and start running.

The emulation mode has a few minor weak points. If you have an Apple III Silentype printer, it will not be accessible in emulation mode unless you install an Apple II Silen-

# HAVEN'T YOU HEARD OF THUNDERCLOCK PLUS™?



If you want to put your Apple® to work — around the clock — Thunderclock Plus is the solution. Just plug it in and your programs can read the month, date, day of week and time — down to the second — in any of Apple's languages. So your Apple can do any number of tasks for you automatically. In the office, the lab or at home.

Most good software packages for business, data base management, communications and time management are made to read Thunderclock Plus. (It's compatible with DB Master,\* Micro-Courier\*\* and VisiDex†, to name a few). So no matter how you use your Apple now, Thunderclock Plus can make it a more versatile and efficient tool.

For example, with business or communications software, your Apple can automatically access a data base or send electronic mail when the rates are lowest.

In addition, Thunderclock Plus can organize your disk files. Our optional DOS-DATER™ software upgrades the regular DOS on your disks. So every time a program is saved or a file is modified, the time and date, *to the minute*, are stored in the CATALOG with the file name. Now you can instantly know exactly when your files were last updated.



*Thunderware's DOS-DATER time and date stamps your disk files to the minute.*

Thunderclock Plus can even give you a sense of security. Or just make your life a little easier. With our X-10 interface option and a BSR X-10‡ Home Control System, your Apple can turn on your lights, water your lawn... whatever you desire, according to schedules you create. It comes with our menu-driven SCHEDULER software. So it's easy to design and modify schedules that can run in the "background" while you have "hands-on" use of your Apple.

Thunderclock Plus comes with a one-year warranty. Powered by on-board batteries, it runs accurately for up to four years without battery replacement.

So now that you've heard of Thunderclock Plus, isn't it time you put your Apple to work — around the clock? See your dealer for a demonstration or contact us.

THUNDERCLOCK PLUS and BASIC software	\$150
DOS-DATER/DEMO disk	\$ 29
X-10 Interface option	\$ 49
PASCAL software disk	\$ 29

\*Apple is a registered trademark of Apple Computer, Inc.

\*\*DB Master is a registered trademark of Stoneware, Inc.

\*\*Micro-Courier is a registered trademark of Microcom.

†VisiDex is a registered trademark of VisiCorp.

‡BSR X-10 is a registered trademark of BSR (USA) Ltd.



## THUNDERWARE, INC.

44 Hermosa Ave., Oakland, CA 94618 (415) 652-1737

Circle 462 on Inquiry card.

## At a Glance

### Name

Profile Winchester-technology disk drive

### Manufacturer

Apple Computer Inc.  
20525 Mariani Ave  
Cupertino, CA 95014  
(408) 996-1010

### Price

\$3499

### Storage Capacity

5 megabytes (equivalent to about 35 normal Apple 5¼-inch floppy disks)

### Size

Height 4.39 inches (11.5 cm), width 17.28 inches (43.89 cm), Depth 8.81 inches (22.38 cm)

### Weight

11 pounds (5 kg)

### Power Required

110 volts AC, (U.S.), 35 watts

### Hardware Required

Apple III computer

### Software Required

Apple SOS 1.1

### Organization

Four data surfaces, 153 tracks per surface, 16 sectors per track, 512 bytes per sector, 2448 sectors per surface, 9792 sectors per drive

### Specifications

Data transfer rate: 5 megabits per second; average seek time: 95 milliseconds; rotational speed: 3600 revolutions per minute; ready to operate: 60 seconds

### Interface

Interface card occupies one Apple III expansion slot; one drive per interface card, up to four drives per system

### Special features

Power-up self-test and disk scan; automatic bad-sector relocation; error checking and limited error correction

type interface card, which may violate FCC radio-frequency radiation limits. Nor can you access the Profile hard-disk drive—Apple II and Apple III files won't mix on the same disk. Also, the RGB (red-green-blue) video outputs will not provide color signals while emulating Apple II graphics, but the composite video outputs will work normally.

## The Profile

The Profile hard-disk drive is the newest component of the Apple III family and a worthy occupant of an expansion slot. With a 5-megabyte capacity, integral Z8-based controller, and built-in power supply, the Profile is a self-contained intelligent subsystem with its own self-test, error

checking, and bad-sector relocation facilities.

When powered up, the Profile's controller waits for the disk to come up to speed and does a data integrity check by stepping from track to track to verify that all disk sectors read correctly. If a bad sector is found, either during this process or during normal activity, the Profile attempts to correct the data errors and then relocates as much data as possible to an alternate good sector.

The key component in the Profile is the ST-506, a 5¼-inch hard-disk drive manufactured by Seagate Technology Inc. The ST-506 uses the sealed disk environment and low-altitude (10-micron) flying heads that characterize all Winchester-tech-

nology disk drives (see photo 11). Because a number of vendors produce drives that are plug-compatible with the ST-506, Apple should have no trouble producing Profiles even if Seagate's supplies get short.

During operation the disk drive is relatively quiet, emitting a soft tone as it steps from track to track. Between accesses you can hear the main drive motor, but the sound should not be obtrusive or even audible in most office environments.

The Profile is styled to match the rest of the Apple III system and may be positioned on top of or adjacent to the computer.

I found the Profile a pleasure to use. Its capacity is equivalent to that of about 35 normal Apple floppy disks, and its data throughput is about 10 times faster. Viewing its capacity in other terms, the Profile can hold over 1200 pages of typed text or more than 300 high-resolution graphics pictures occupying 16K bytes apiece.

The Profile's performance is excellent. In the disk-access benchmark programs shown in listing 2, the Profile effectively tripled the program speed when compared to an Apple or IBM floppy disk. Considering that a significant proportion of the program execution time is used to execute the BASIC program statements, the actual increase in disk-access speed would seem to be even higher. (The results of the disk-access benchmarks are summarized in table 7.)

The weakest point of the Profile and other similar products is data backup. If a hard disk fails, you can lose a great deal of important data. The only solution is to periodically back up the most critical files onto floppy disks or onto a second Profile hard-disk unit. (Apple Computer will happily allow you to connect up to four Profiles to your Apple III, at a total cost of \$13,996 in addition to the cost of the Apple III.) However, chances are very slim that the entire Profile would be wiped out if a critical component failed. After repair, it should be possible to recover virtually all the original data in most cases.



One company has sold more printers  
to this planet than anybody.

# Epson.

By now, that shouldn't come as a surprise. After all, we *invented* digital printers for the 1964 Tokyo Olympics. We've built more print mechanisms than the rest of the manufacturers in the world combined. And our MX Series is the best selling line of printers for small computers ever seen.

So is it surprising that the world's first Notebook Computer should come from Epson?

Not to us. You see, we have some other notable feats in our past. Not only the world's first printer, but the world's smallest printer, the world's most reliable printers, the world's first disposable print



head, and now, the world's first portable computer with the power of a desktop.

We intend to be as big in personal computers as we are in printers. And we'll do it the same way. By making computers you can count on to perform. With the options, software and interfaces you need. And by delivering what we promise, at prices people can afford.

But some people don't think we can do in

computers what we've already done in printers. And for them, we have this advice:  
Just watch.



**EPSON**  
EPSON AMERICA, INC.

3415 Kashiwa Street • Torrance, California 90505 • (213) 539-9140

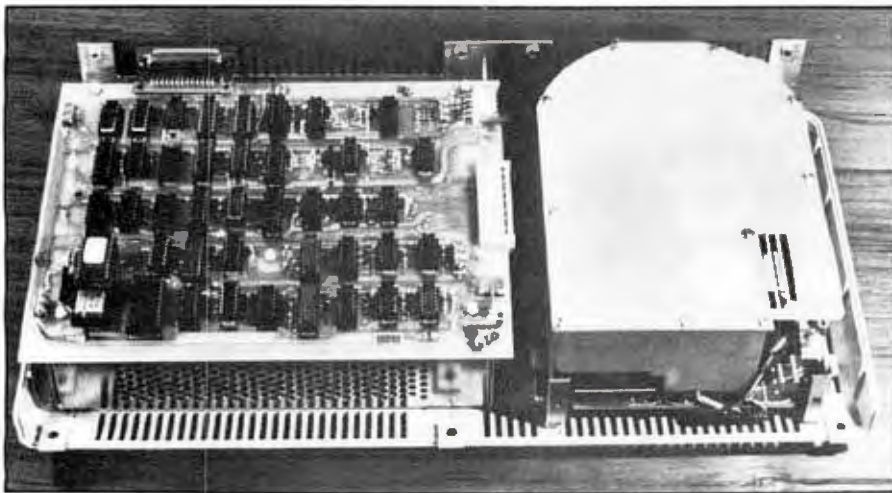

Photo 11: The Profile with its top cover removed. The intelligent controller is shown on the left with the switching power supply beneath it. The HDA (hard-disk assembly) with its sealed internal environment is mounted on the right.

	Apple III Profile	Apple III Floppy Disk	Apple II Floppy Disk	IBM Floppy Disk
Write	13.2	37.3	234	32
Read	10.2	33.2	273	22.9

Table 7: A summary of disk-access-time benchmarks comparing the performance of the Apple III Profile hard-disk drive and the Apple III, the Apple II, and the IBM Personal Computer floppy-disk drives. The table shows the times (in seconds) taken to read and write 500 disk records.

## ALF COPY SERVICE

FAST • RELIABLE • LOW COST

If you need your software duplicated quickly and conveniently, ALF's disk copying service is the answer. Most orders are shipped in less than a week. Every disk we copy is verified bit by bit and guaranteed 100% flawless. Standard formats include Atari, Apple (including nibble-copy-proof and double-boot formats), and TRS-80 model 1.

Our "no frills" pricing means you don't have to buy extras you don't need. Of course, we have the frills too — including custom printing and packaging. Call us today for complete details.

**BLANK 3M  
DISK \$1.65**  
BOX OF 100

**COPIED 3M  
DISK \$1.95**  
MULTIPLES OF 50

ALF (303) 234-0871 1448 ESTES DENVER, CO 80215

At \$3499, the Profile isn't inexpensive—none of the available hard-disk subsystems are—but it provides a truly significant extension to the capabilities of the Apple III system.

### Documentation

Apple Computer's documentation has always been excellent, and the manuals provided with the Apple III are no exception. All the manuals are in the familiar 6- by 8½-inch (12.8-by 21.6-cm) format, and a new flap has been added to the back cover so that the manual title is visible while the book is on the shelf. The manuals are all clearly written with numerous charts, tables, and screen photos to illustrate points described in the text.

With a Business BASIC system, you receive four manuals: the *Owner's Guide* and *Standard Device Drivers* deal with Apple III features and SOS, while volumes one and two of *Apple Business BASIC* provide a comprehensive description of the language.

The *Owner's Guide* explains how to set up the Apple III system and describes various aspects of SOS and the Apple III hardware. There are sections about system installation and start-up, the operating system, the System Configuration Program, and the machine itself. Appendixes explain error messages, describe proper disk care and handling, give I/O port specifications, and tell you how to use the Apple II Emulator. The information is presented in a clear, easy-to-read style and should be sufficient to get any novice started.

*Standard Device Drivers* provides complete specifications and descriptions of the operation of all of the standard I/O device-driver routines. After a short section that explains what device drivers are, the manual describes the System Configuration Program. Separate sections describe each individual driver in detail. The appendixes contain quick references for all the drivers, an explanation of the system error messages, and a description of the console data formats.

With a BASIC system, you'll get *Business BASIC* volumes 1 and 2. Although the manuals were not de-

# Performance Breakthrough...

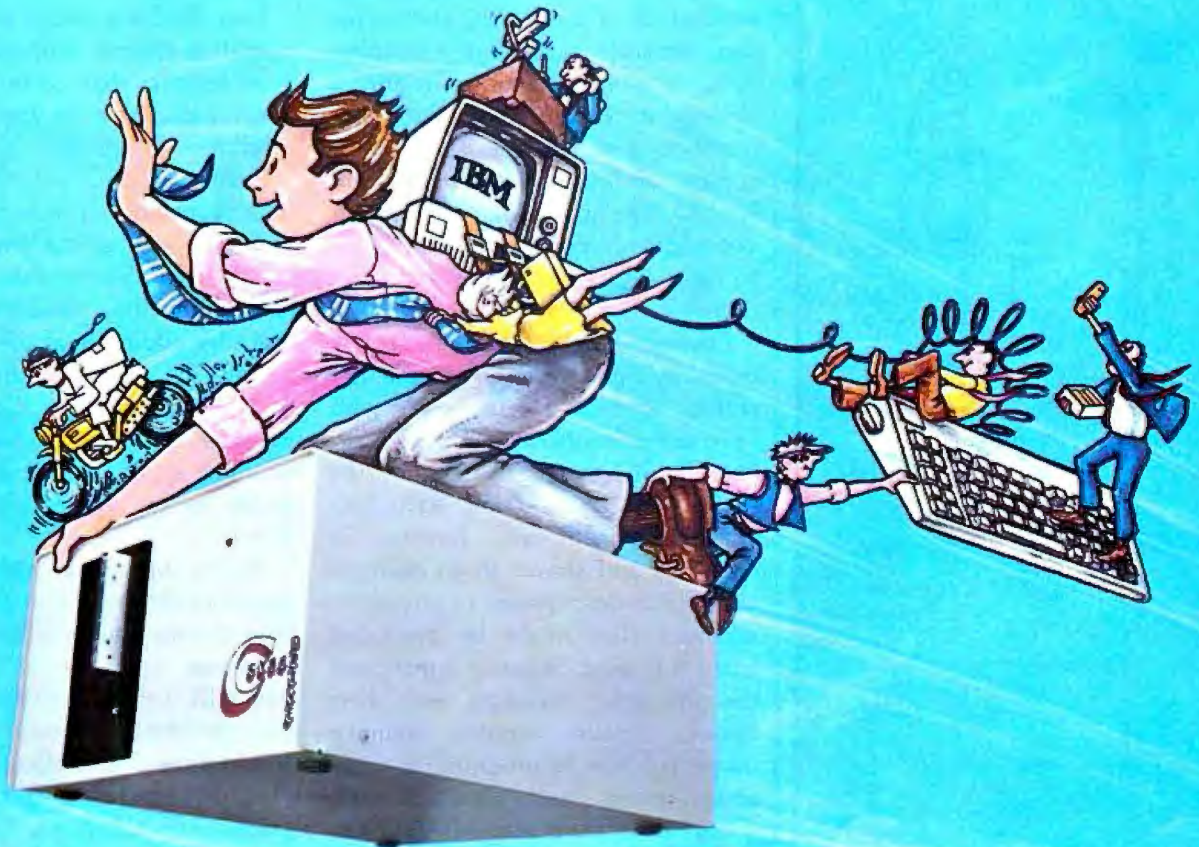

## ... the **CYBERDRIVE™** for the IBM Personal Computer 13.5 or 27 million bytes of disk capacity in a single cabinet with an integrated mini-cartridge tape for secure data backup.

Setting an exciting new microcomputer standard, the **CYBERDRIVE<sup>1</sup>** combines a full package of features.

It offers new, higher performance levels, with an integrated business-oriented backup device.

As the **CYBERDRIVE** is made available for other systems, media transfer is assured regardless of the host hardware or Operating System.

The **CYBERDRIVE** slashes the seek time dramatically—e.g. the usual 5 Megabyte stepper-motor Winchester disk offers average seek time typically in the range of 100 to 200 milliseconds (incl. head settling).

With the **CYBERDRIVE**, the average seek time across more than five times as much data is only 33 milliseconds (incl. head settling).

This basic speed, coupled with disk cache buffering and a peak transfer rate of 1 million bytes per second, make the **CYBERDRIVE** a performance champ!

The integrated mini-cartridge tapes used for backup of data allow dumping of (for example) 10 million bytes of data in about 10 minutes... much faster than other tape or floppy disk backup techniques. Hardware read-after-write error checking is incorporated in the tape device.

... And don't fail to ask about our superb lineup of serious business software (also offered in **CYBERDRIVE** format) including:

- RM/COBOL<sup>2</sup>** compiler—the micro industry standard.
- MBSI<sup>3</sup> RM/COBOL** general business applications (derived from **MCBA<sup>4</sup>** minicomputer packages)... thousands in use... money back guarantee... source program license.
- CRTI<sup>1</sup>** from Cybernetics (**COBOL Reprogramming Tool!**)—Program generator for **RM/COBOL** to ease program development and maintenance... an alternative to a Data Base System.
- CBASIC<sup>2</sup> & CBASIC86<sup>5</sup>** compilers... for aficionados of a useful BASIC.

The software is available on a variety of industry-standard Operating Systems including **CP/M<sup>6</sup>-MP/M<sup>6</sup>** (both -80 & -86), **OASIS<sup>7</sup>**, **PCDOS**, and **UNIX<sup>7</sup>**. Inquire for specific details and prices.

Trademarks of:

1 Cybernetics, Inc. 2 Ryan-McFarland Corp. 3 Micro Business Software, Inc.  
4 Minicomputer Business Applications, Inc. 5 Digital Research, Inc. 6 Phase One Systems, Inc. 7 Bell Laboratories



# S O R D<sup>TM</sup>

The most powerful Screen Oriented Relational Database ever designed that requires no user programming!

SORD puts You in control of a powerful information management system: quickly, easily, and at a new low price!

#### Powerful

- User defined CRT entry screens speed data input and editing.
- Makes full use of CPM 2.0+ facilities for rapid access and retrieval.
- User controlled security access codes.

#### User Oriented

- A consistent system of help messages, menus, and prompts assists the user in all phases of operation.

#### Clear Documentation

- Our manual is concise, easy to understand, and indexed.

#### Price Reduction

- Sales volume - new low price
- Rebates for current users

**\$195**/\$25 manual

VISA, MC and COD welcome

**ISOTECH<sup>TM</sup>**  
 INNOVATIVE SOFTWARE TECHNOLOGIES-INC  
 2640 POWELL STREET  
 ANN ARBOR, MICHIGAN 48104

(313) 996-1890

REQUIRES CPM 2.0+ SYSTEM WITH ATLEAST 42K, 64-80 COLUMN SCREEN, ADDRESSABLE CURSOR AND 8" DISK DRIVES. (5 1/4" Formats Soon)

\*CP/M is a trademark of Digital Research, Inc.

signed to teach BASIC, the 335 pages contain all the information required to learn Apple's version of that language. Volume 1 is primarily a tutorial section; it gives clear explanations of all of the BASIC statements and provides numerous examples. After a short introduction and a description of the BASIC editor, different sections describe BASIC I/O, control of program execution, and file I/O. The manual also explains invocable modules and shows you how to use external procedures and functions.

*Business BASIC* volume 2 is primarily a quick reference guide that will be of most use to people who have some familiarity with the Business BASIC language. Within the BASIC reference section, each language statement and function is described and shown in an example along with descriptions of any error messages that might be produced when it is used. Separate appendixes describe error messages and their causes, explain variable memory usage, tell how to program for maximum speed, and give syntactic definitions of the Business BASIC language. The Graphics invocable module (BGRAF.INV) is described in a 57-page section that gives detailed examples of plotting and drawing, saving pictures on disk, creating graphics text fonts, and setting up your own color and transfer tables.

If you purchase Apple III Pascal, you'll get an additional four manuals that describe the Pascal system, utility programs, and the Pascal language. One distinct benefit of Apple III Pascal is that the description of the Pascal assembler provides details about the 6502 enhanced features that are not found in any of the other manuals. Unfortunately, even though the BASIC invocable modules are written in Pascal, the manuals do not tell you how to write them. This may not be important to small-business users; nevertheless, the information should be available.

#### Summary

It is impossible to do the Apple III justice in one article. The machine is

very flexible and has a mix of features and capabilities that are unmatched in any of its competitors. Some points, however, deserve special mention.

First, SOS is a unique and powerful operating system; it provides a variety of features that, as far as I know, are not available on any other 8-bit machine.

Business BASIC is also very powerful and includes options not found in most versions of the language. The use of invocable modules allows the user to maximize available memory space by adding only the capabilities needed. Its I/O-formatting and file-handling capabilities are extremely versatile and, for most business data-handling applications, will allow programs to be shorter and easier to debug.

As for hardware, although some people might argue that Apple should have chosen a more advanced micro-processor than the 6502B for the Apple III, I think the company made the right choice. Without the 6502B it would have been difficult, if not impossible, to transfer files and programs from the Apple II to the III, and Apple II emulation would not have been possible. Admittedly, it was a conservative choice—more powerful processors are available—but actual processor performance is much less important than software availability. Apple's choice clearly maximizes the usability of the system.

The Profile hard-disk drive is a significant enhancement to the Apple III. Its speed and high capacity will eliminate 99 percent of the disk swapping required when using only floppy disks, and the SOS nested directory structures will keep it well organized.

Finally, one of the strongest points in favor of the Apple III is Apple Computer Inc. When early Apple III users had problems with the first machines, Apple simply replaced the entire computer immediately—as many as two or three times in some cases. This unqualified backing of its products shows a commitment to customer satisfaction unequalled in the industry. ■



SEIKOSHA  
GP-100A

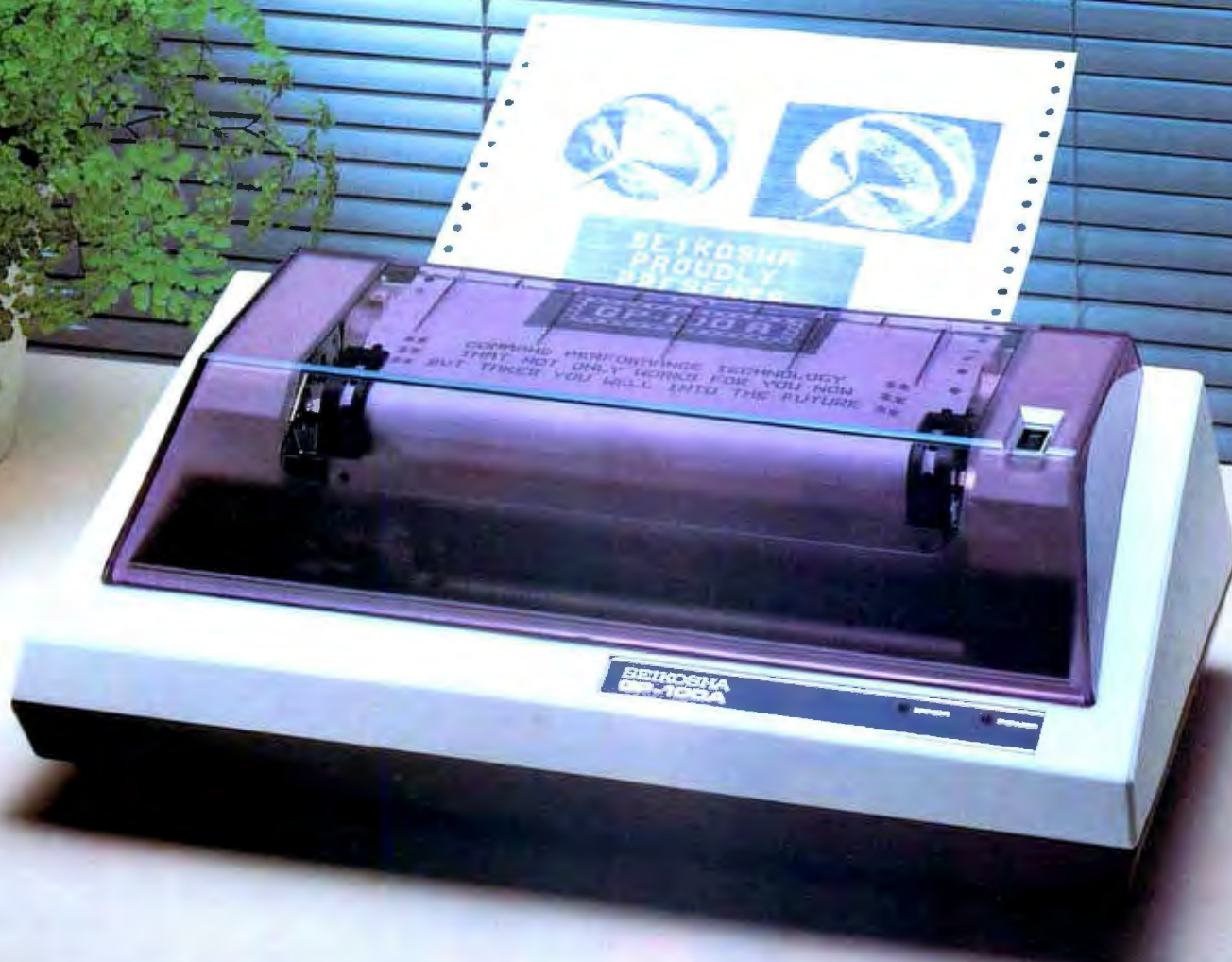

GP-100A: US\$389

## COMMAND PERFORMANCE.

Seikosh gives you all the best features—including economy and super-clear graphics.

Unlike some graphic printers, Seikosh's new GP-100A Uni-Hammer Graphic Printer puts full dot addressable graphics at your command. The GP-100A lets you repeat a column of data as many times as needed with just one command. Software control enables double-width character output, and the positioning is both character and dot addressable. Designed for simple operation, it ranks among the most cost-efficient graphic printers on the market. Command performance technology that not only works for you now, but takes you well into the future.

Other valuable features:

- Graphics, regular and double width character modes can be intermixed on the same line.
- Automatic printing. When the text exceeds the maximum line length, there is no loss of data due to overflow.
- Self-test printing is a standard feature.
- Centronics type parallel interface.
- Paper width is adjustable up to 10 inches.
- Optional Interface: RS232C, IEEE488, apple II, etc.

Graphic Printer  Series

Available at COMPUTERLAND and other fine stores in your area

Distributed by **AXIOM CORPORATION** 1014 Griswold Avenue San Fernando, Calif. 91340 Phone (213) 365-9521 TWX (910) 496-1746  
Manufactured by **SEIKOSHA SYSTEM EQUIPMENT DIV.** 4-1-1 Taihei Sumida-ku Tokyo Japan. Phone: 03-623-8111 Telex: 262-2620

Circle 8 on inquiry card.

# QUADBOARD™

THE FIRST AND ONLY  
BOARD YOUR IBM PC  
MAY EVER NEED.

Your IBM personal computer is a very versatile piece of equipment. Perhaps more versatile than you realize. New applications and functions are being developed every day. Now with Quadboard

by Quadram you can keep your options open for tomorrow's technology. Following in the tradition of Quadram Quality, four of Quadram's best selling IBM boards have been combined into one board. Your remaining slots will be left free and available to accommodate future expansion needs and uses which you may not even be able to contemplate today.

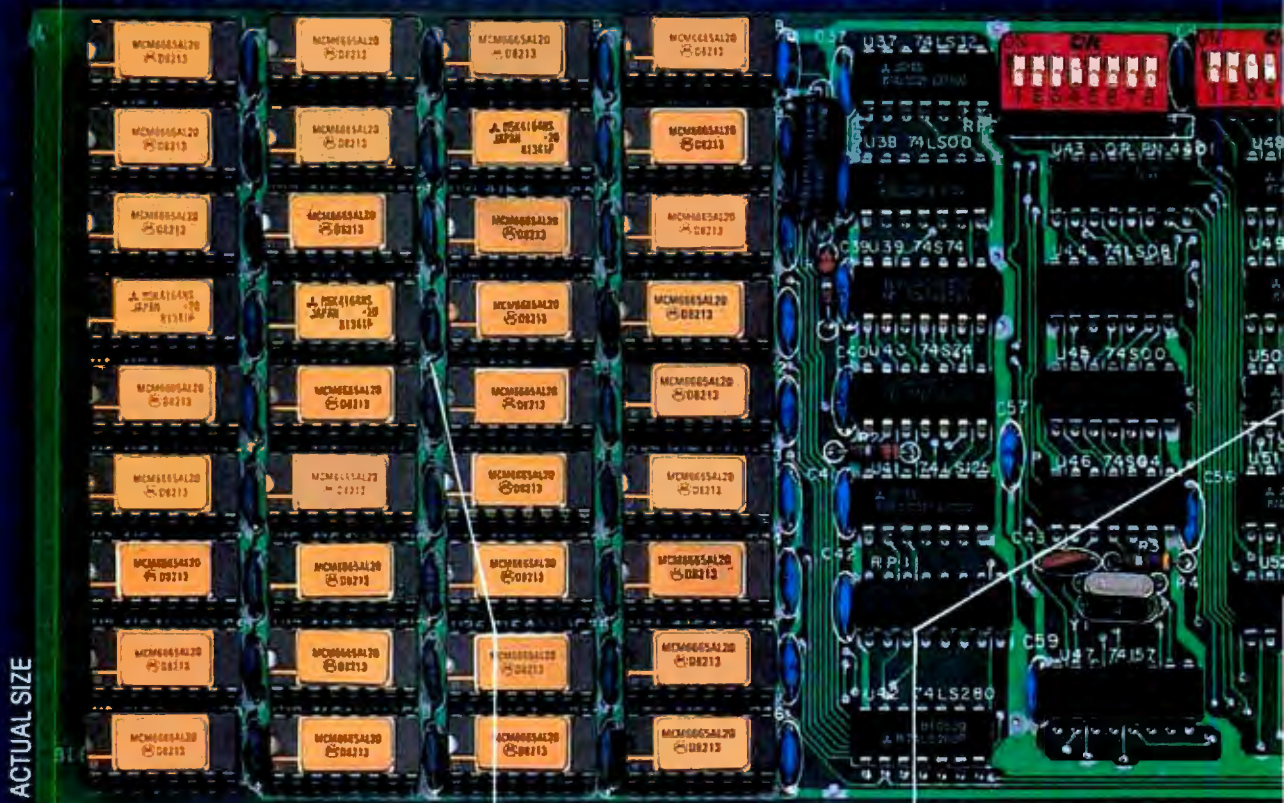

ACTUAL SIZE

#### PROVEN DESIGN.

Quadram has been shipping IBM boards with each of the Quadboard functions on separate boards since December, 1981. They are still available as separates (including a Dual Port Async Board) for those who desire a quality board but do not need to keep slots open for future expansion. And they all come with a one year warranty from the leader in technology applications.

#### 256K MEMORY EXPANSION.

Socketed and expandable in 64K increments to 256K, full parity generation and checking are standard. A Quadboard exclusive feature allows parity to be switch disabled to avoid lock-up upon error detection. The dip switches also allow it to be addressed starting on any 64K block so that it takes up only as much as it has memory installed. Memory access and cycle time naturally meet all IBM specifications.

#### CLOCK/CALENDAR.

Quadboard eliminates the hassle of manually inputting the date on system boot-up by providing for the clock and all software routines necessary for inserting the appropriate programs on your diskettes. The internal computer clock is automatically set for compatibility with most software routines which utilize clock functions. On-board battery keeps the clock running when the computer is off.

# BY QUADRAM

## ALL ON ONE BOARD

Now you can utilize all the PC's capacity with Quadram's extremely flexible configurations. And it's totally compatible with IBM hardware, operating systems, and high level languages. It's a full-size board that can be inserted into any free system slot and it even includes a card edge guide for securely mounting the card in place.

## INCREDIBLE PRICE!

Priced at \$595 with 64K installed, \$795 with 128K, \$895 with 192K and an unbelievable \$995 fully populated with 256K. Quadboard! You pay less for more and still protect the few limited empty slots in your computer.

**\$595**

with 64K  
Installed



## PARALLEL PRINTER I/O.

A 16 pin header on Quadboard is used for inserting a short cable containing a standard DB25 connector. The connector is then mounted in the knock-out hole located in the center of the PC backplane. The parallel port can be switch disabled or addressed as Printer 1 or 2. No conflict exists with the standard parallel port on the Monochrome board. The internal cable, connector and hardware are all included.

## ASYNCHRONOUS (RS232) COMMUNICATION ADAPTER.

Using the same chip as that on the IBM ASYNC board, the device is software programmable for baud rate, character, stop, and parity bits. A male DB25 connector located on the back connector is identical to that on the IBM Async Adapter. The adapter is used for connecting modems, printers (many letter quality printers require RS232), and other serial devices. Switches allow the port to be configured as COM1 or COM2 and the board fully supports IBM Communications Software.

## AVAILABLE NOW!

Quadram does not advertise products until shipments have begun. Count on it. But order today for immediate delivery.

## ASK YOUR DEALER.

All products are sold through local personal computer dealers. If yours does not stock Quadram, please ask him to call us at (404) 923-6666.

**QUADRAM**  
CORPORATION



Circle 388 on inquiry card.

4357 Park Drive / Norcross, Ga. 30093

# Computers Can Play a Dual Role for Disabled Individuals

*Besides providing special assistance, microcomputers should give disabled individuals access to standard software.*

---

Gregg Vanderheiden, Director  
Trace Research and Development Center  
314 Waisman Center  
1500 Highland Ave.  
Madison, WI 53706

---

The move toward more portable and flexible microcomputers is revolutionizing the design and development of electronic assistive devices for the disabled, ensuring the status of powerful, low-cost microcomputers as valuable tools for disabled individuals and those working with them.

The past few years have witnessed a tremendous increase in the number of individuals and small groups involved in the development of special aids for disabled persons. Microcomputers have given individual designers who don't have access to extensive laboratory and production facilities the capability of developing sophisticated electronic aids. This is not to say that the design of aids to assist disabled individuals is easy or can be easily developed in a few

weekends or evenings. The worthwhile developments in this area have taken a lot of time and effort, not only in programming and interfacing, but also in carefully studying the real needs of the disabled individuals and the many barriers and practical considerations that are involved in the successful applications of technology to meet their needs.

---

## **Worthwhile developments require careful study of disabled individuals' real needs.**

---

The influx of new people into this area has resulted in a wealth of new ideas, energy, and enthusiasm. The purpose of this article is to provide an overview of some of the many areas in which microcomputers can serve the needs of disabled individuals and to discuss a few major concepts important to the development of successful applicable software. I hope

this overview will stimulate new ideas, approaches, and applications for microcomputers in those interested in getting involved in designing for the disabled. The basic concepts presented can help you learn from and build upon, rather than duplicate, the early work and mistakes in this area.

### **A Dual Role for Microcomputers**

When we first think about the use of microcomputers by disabled individuals, our minds usually turn to thoughts of text-to-braille translating programs, special communication aids, programs that can teach sign language, etc. These all involve the development of special software that can be run on the computer to provide a specific function required by a disabled individual.

In considering the use of computers by disabled individuals, however, it is very important to remember that disabled people also need to use the same programs and accomplish the same tasks as anyone else. Thus the

---

*Gregg Vanderheiden is director of the Trace Research and Development Center for the Severely Communicatively Handicapped at the University of Wisconsin-Madison.*

---

**PGS****Princeton  
Graphic Systems**

## High Resolution RGB Color Monitor Designed for the IBM Personal Computer

### FEATURES

- 80 characters x 25 lines
- 690 dots horizontal resolution
- 16 colors
- .31 mm dot pitch tube
- non-glare, black matrix
- plugs directly to IBM PC

**\$795**

Princeton Graphic Systems' new HX-12 high resolution color monitor is designed with an NEC .31 mm dot pitch CRT to give you up to 690 dots horizontal resolution. You need not compromise the display quality of your system with monitors rated at less than the 640 horizontal dots generated by your IBM PC. The PGS HX-12 delivers 16 supercolors, 80 characters x 25 lines. It is the best priced performance PC direct drive monitor in the market today. Get the PGS HX-12 and discover for yourself how well it complements your IBM Personal Computer.

**PGS****Princeton  
Graphic Systems**

blind individual who may be able to make good use of a text-to-braille program also needs to be able to use standard text editors, spreadsheet programs (e.g., Visicalc), and database managers, to name only a few. Similarly, the physically disabled individuals who could use a game or writing program that requires only the operation of a single switch also need to be able to use the standard educational software as well as the accounting programs and computers at the companies considering them for jobs. This is the dual role that

microcomputers must fill: they must help disabled persons perform tasks denied to them because of their disability, and they must be physically modified to allow disabled persons to tap all the microcomputers' computing and word-processing powers.

At present, the vast majority of the software being developed for disabled individuals is limited to providing for a special need, rather than allowing the use of common general-purpose software. These special programs (although often quite sophisticated) are generally easy to implement because

the full capabilities of the computer are available to the programmer. They do not, however, address the greater need for disabled individuals to be able to use standard systems.

Trying to provide access to standard software programs for individuals who cannot see the video display or cannot use the keyboard is very difficult. In many cases, the more powerful standard software takes complete control of the computer when it is loaded, disabling the special routines or programs intended to provide access to disabled individuals. This is true even when the special routines are hidden in remote areas of the memory. In addition, the standard programs themselves are often "locked," and the source code is unavailable, making any direct modification of the programs impossible.

Despite the many barriers, strategies are being developed now that can allow extremely motor-impaired individuals to access all standard software, even though the user may have as little controlled movement as an eyeblink.

### Providing Special Functions

It would be impossible to quote an exhaustive list of the special functions microcomputers could provide for disabled individuals. Almost any aspect of human activity that has been impaired could potentially be aided to some degree through the use of microcomputers as processors, manipulators, or controllers.

**Sensory enhancement/translation:** Microcomputers can be used to provide either a clarification of audio or visual information so that it can be more easily understood or a translation from one medium to another. For example, microcomputers can be used to expand visual displays, provide visual displays of auditory information, provide auditory output of visual information, translate a limited, spoken vocabulary into text, and provide tactile displays and feedback to individuals both deaf and blind.

**Manipulator/controller:** For individuals with severe motor impairments, the use of remote actuators and powered artificial remote pros-

## ★ ★ ★ FEATURING 8 and 16 BIT S-100 SYSTEMS ★ ★ ★

WE OFFER A WIDE RANGE OF CRTs, PRINTERS, GRAPHICS EQUIPMENT, SOFTWARE FOR ALL SYSTEMS. EACH SYSTEM COMPLETELY TESTED, INTEGRATED, READY FOR PLUG-IN OPERATION WHEN YOU RECEIVE IT. WE TAILOR & CONFIGURE SYSTEMS TO MEET YOUR BUDGET AND NEEDS. WE CUSTOMIZE SOFTWARE TO YOUR SPECS. WE WELCOME YOUR REQUEST FOR TECHNICAL INFO BY PHONE OR LETTER.

**GRAPHICS SYSTEM:** Architects • Designers • Engineers • Create & store own designs. Create arrays. Zoom, windows. Completely interactive. Easy to edit. Powerful and fast. Package includes software + MicroAngelo Graphics Subsystem + M9900 16 bit, S-100 w/dual 8" floppies, + HI PAD Digitizer + Plotter .....\$10,200.  
★ ★ ★ CP/M\* now optionally available ★ ★ ★

**IMS** 2 yr. warranty on boards! SX systems w/8" or 5 1/4" drives, optional 10, 20, or 40 MB Winchester, built-in tape back-up, Z-80 S-100 bus. On site service for NY quad-state area.

**MULTI-USER IMS:** MPU/slave cards give each user own CPU, 64K RAM, 2 serial ports.

**TURBODOS:** Single or multi-user. Spectacularly FAST CP/M\* compatible Operating System. Cuts link/edit time in half. Z80 Code interrupt driven. Up to 6X faster than CP/M; up to 35% increased disk capacity. For IMS, CCS, NorthStar. New version supports up to 65000 stations, 16 users per station. Each user can have floppies.

**CALIFORNIA COMPUTER SYSTEMS 2210A** High quality, low price. Z80 CPU, 1 serial port, disk controller w/CP/M 2.2 64K RAM .....\$1,775.  
Add our Max Box w/dual Shugarts and IMS I/O w/2 serial, 1 parallel.

**LOMAS DATA 8086 SYSTEM:** Complete Lomas card set in TEI 12 slot mainframe, 86-DOS, dual Shugart 801s, Televideo 912, assembled & tested .....\$4,599. Options: 8087 .....add \$600; 8089 .....add \$100.

**SEATTLE 8086 SYSTEMS** Featuring 86-DOS, the IBM PC Operating System.  
System I: 8MHZ CPU set w/1 serial, 1 parallel I/O (additional I/O option) 64KB 16 bit Static RAM, Tarbell DD controller, TEI 22 slot mainframe w/constant voltage transformer .....\$2,695 System II: with 128K Static RAM .....\$3,550.  
Interfaced to dual Shugarts 801 .....\$1,275, or dual QUME DT-8 .....\$1,680.

**GODBOUT/CROMEMCO/SYSTEMS GROUP:** Complete product lines at discount prices.

**MAX BOX DISK DRIVE SUBSYSTEM** mfg by John D. Owens Assoc. Dual drive cabinet w/regulated power supply, fan, complete internal cabling. Will hold Shugarts, Qumes, Tandons and/or 8" Winchester, horizontally mounted. Excellent design and engineering. 17 1/2 x 5 1/2 x 22. Attractive buff color.  
W/2 Shugart 801 .....\$1,275 W/2 QUME DT-8 dble sided drives .....\$1,605.

Prices subject to change without notice Write or call for free catalogue

# JOHN D. OWENS Associates, Inc.

12 Schubert Street, Staten Island, New York 10305  
212 448-6283 212 448-2913 212 448-6298

theses (or robotics) to give them manipulative capabilities has been proposed. One of the difficulties has been the large number of signals that are required in order to control such robots or manipulators. One role for microcomputers might be to help control these remote manipulators by developing and remembering complex movement command strings for specific types of activities. These command strings could then be called upon by the user, using a small number of commands, thus allowing complex motions to be made with reasonable speed and ease.

**Information amplification (for motor impaired):** The problem of slow information transfer is not restricted to the manipulator/control field. In fact, its greatest impact is probably in the area of communication and writing. Here the speed with which one can transfer information is crucial, and the demand for reasonable speed is extremely high. A difference in speed by a factor of 4 or 5 (the average factor for a motor-impaired individual is around 10 to 20) can make the difference between being able to complete a day's work in a day and taking a week to accomplish a day's work. Similarly, it can be the difference between being able to complete one's homework each night and being able to do one night's homework every week or two. The microcomputer can be used in a number of ways, however, to increase or amplify the amount of information that can be relayed with a given number of keystrokes or signals. Most of these techniques take advantage of redundancy in information transferred, but others are more involved.

A simple example would be an abbreviation expansion routine that would allow an individual to abbreviate all commonly used words and greatly reduce the number of keystrokes required to type out messages, programs, etc. The program would automatically expand the abbreviations as the user typed them. The abbreviations could represent commonly used words, mnemonics, phrases, sentences, or entire blocks of frequently used information.

Another technique would be to use a large word-base that could anticipate the word being typed, thus truncating the process of spelling words out. This can be done based upon word and letter frequency. More elaborate schemes involve looking at idea-to-text or concept-to-text (or even concept-to-speech) translation.

Also being explored is a semantic-feature-based phrase/sentence recall system in which three to five keystrokes would define an entire sentence (see "Minspeak" by Bruce Baker, page 186). Only about 60 keys

are involved, but their meanings vary as a consequence of the order in which they are pressed. Although this approach at first seems complex, a system like this may be necessary in order to provide the information amplification necessary to offset the severe information-transfer problem that many motion-impaired individuals have. Advances in this field need not be limited to assisting disabled individuals either.

**Special control interfaces to other devices:** A general method for increasing the information-transfer rate

JOHN D. OWENS ASSOCIATES INC. JOHN D. OWENS ASSOCIATES INC. JOHN D. OWENS ASSOCIATES INC. JOHN D. OWENS ASSOCIATES INC. JOHN D. OWENS ASSOCIATES INC.

## SYSTEMS INTEGRATION SPECIALISTS

IBM PC USERS IBM PC USERS IBM PC USERS IBM PC USERS IBM PC USERS

**IBM 3270 USERS - Teletype Model 45**  
Cluster controllers, terminals, printers. Bisync or SNA/SDLC protocol, local or remote connect. Up to 32 devices on one cluster. Cost effective! Fast delivery!

**MICROANGELO GRAPHICS**  
SUBSYSTEM w/LIGHT PEN ... \$2,300.  
Without light pen ... \$1,930.  
Graphics card alone ... \$ 975.  
Screenware Pak II or TEKEM ... \$ 350.  
Color systems from 4 to 256 colors.  
Basic color system (4 colors) ... \$2,330.

**HOUSTON INSTRUMENTS**  
PLOTTERS Standard & Intelligent models w/surface areas of 8 1/2" x 11" to 11" x 17".  
DMP-2 ... \$ 935. DMP-3 ... \$1,195.  
DMP-4 ... \$1,295. DMP-5 ... \$1,455.  
DMP-6 ... \$1,685. DMP-7 ... \$1,865.  
Hi Pad Digitizer ... \$755.

**HAYES MICRO MODEM 100** ... \$359.  
Smartmodem. \$251. Chronograph. \$224.

**PER SCI: Model 299B** ... \$2300.

**TEI MAINFRAMES, S-100**  
MCS 112 ... \$620. MCS 122 ... \$745.  
RM 12 ... \$655. RM 22 ... \$790.

**TARBELL DD Controller** ... \$435.

**COMMUNICATIONS SOFTWARE**  
Micro to terminal to micro to mainframe to modem. HAWKEYE GRAFIX \$500

**PMMI S-100 Modem** ... \$385.  
Telex & Twx, On board dialer.

**TELETYPE**  
Model 4320 AAK ... \$1,140.  
Model 43ASR, 8 level, 1" tape ... \$2,595.

**MEMORY MERCHANT**  
64K RAM ... \$716.

**dBASEII demo package** ... \$ 75.  
**dBASE complete software** ... \$595.

★ IBM PC USERS ★

**SEATTLE COMPUTER RAM PLUS**  
64K RAM + SERIAL I/O ... \$418.  
128K RAM + SERIAL I/O ... \$594.  
192K RAM + SERIAL I/O ... \$770.  
256K RAM + SERIAL I/O ... \$942.  
64K Chip Kit ... \$176.  
Each RAM card has an RS232 serial port which uses IBM supplied software. Boards socketed for easy upgrade.

**8080/8086 EMULATOR** runs CP/M® on IBM PC. All I/O runs at operating system speed ... \$200.

**AMDEK COLOR II MONITOR** ... \$810.

**MICROSOFT RAMDrive** Expands physical memory AND implements RAMDrive. Allows high speed access to files normally stored on diskette  
64K ... \$420. 128K ... \$590.  
192K ... \$760. 256K ... \$930.

**IDS PRISM COLOR** 132 columns \$1,795.  
Enhanced 560 w/software selectable colors; high speed printing to 200 cps.  
PRISM 80 ... \$1,615.  
PRISM 80 BLACK ... \$1,255.

**BABY BLUE: Z-80B, 64K RAM** substitutes for IBM memory card in IBM PC. Will run Z80, CP/M® software ... \$600.  
w/Wordstar® & Mail Merge™ totally configured for IBM keyboard ... \$980.

**CORVUS HARD DISK SYSTEMS**  
6.7MB ... \$3,035. 11.3MB ... \$4,745.  
20.5MB ... \$5,695.

**EPSON MX 80** ... \$475.  
MX80 F/T ... \$575. MX 100 ... \$725.

**3M SCOTCH DISKETTES FOR IBM PC** 744 ss/sd ... \$ 26.

**MICROBYTE IBM-1** Five slot expansion chassis ... \$805.

We are evaluating new products for the IBM PC as they are announced. Please call us for complete, up-to-date listing.

**WE EXPORT** Overseas Callers: TWX 710 588 2844  
Phone 212 448-6298 or Cable: OWENASSOC

# JOHN D. OWENS Associates, Inc.

SEE OUR AD ON FACING PAGE

uses microcomputers to provide a special interface between the disabled individuals and the device(s) that they are trying to control. The purpose of this special interface would be to obtain the best possible match between individuals' residual capabilities and the characteristics of the systems that they are using.

Depending upon the severity of the physical handicap, these special interfacing techniques can take a variety of forms. For severely disabled individuals, single-switch input systems can be used; the microcomputer continually presents choices to the user until the user responds by activating a switch.

More common and effective, however, are various special direct-selection or encoding input techniques. For individuals who have head control, screen-based optical headpointing schemes (similar to a long-range light pen) can be used. Other individuals may use expanded and/or recessed keyboards. For those who are able to point but unable to

point to a large enough array of elements to represent a full keyboard, smaller arrays consisting of numbers can be used in an encoding fashion to specify the letters, words, etc. Efforts are also currently being directed toward cost-effective methods of using the eyes, both for encoding and

**A special interface obtains the best match between individuals' residual capabilities and the characteristics of the system they are using.**

for direct selection of items from a display. All of these approaches can be adapted in size and arrangement in order to meet best the needs and capabilities of specific individuals.

**Recreation and development aids:** Disabled individuals can, of course, use microcomputers to play games in

the same manner as anyone else. For individuals with severe physical or sensory disabilities, however, microcomputers can play a more extensive role than just recreation. For example, manipulation of objects and exploration of environment important to development in children may not be possible. A specially interfaced microcomputer may be able to offset some of this disability by providing children with a reliable means to control, explore, and manipulate objects either in real space or on a video display. It may also allow individuals to be able to move themselves about in space to gain new perspectives on their environments as well as to reach and act on the objects in it.

**Educational aids:** In the educational field, a number of specific problem areas can be addressed in part by microcomputers. One area of difficulty involves the slow rate of response of severely physically disabled individuals. This response rate makes any remedial drill or practice session extremely time-consuming

**PICK A SYSTEM!**



**\$2495.**  
**.5 MB STORAGE**



**\$2995.**  
**1.2 MB STORAGE**

**◀ COMPLETE ▶**

We're offering you our SB-80 system in either 5 1/4" or 8" disk drives, your choice. Either way your system comes with a full size (12" diagonal) non-glare tiltable green screen with 24 lines by 80 character format. Its multi-character set offers blinking cursor, underlining, reverse video, and half and zero intensity. The movable, detachable keyboard has a numeric pad with cursor control and function keys.

- Single Board Technology ■ CP/M® Operating System
- 4 MHz Z80A CPU ■ 64K 200ns Main Memory
- 8-Inch Dual Density Floppy Drives
- 5 1/4-Inch Dual Density Floppy Drives
- 2-Serial Ports ■ 2-Parallel Ports
- 4-Counter/Timers ■ Expandable

For further information about this limited offer call or write:



**Colonial Data**

Nationwide on-site and depot repair service through the professionals at INDESERV

\*CP/M is a registered trademark of Digital Research, Inc.

Colonial Data Services Corp., 105 Sanford Street, Hamden, Conn. 06514 • (203) 288-2524 • Telex: 956014



In this age of runaway inflation...

# Look what \$825\* will buy



## The HIPAD™ digitizer

### Inexpensive input to your computer

The HIPAD™ digitizer can be used for both converting graphic information into digital values and as a menu. Utilizing either the stylus or the optional cursor, the operator can input graphic data into the computer by locating individual points on the digitizers 11" x 11" (28cm x 28cm) active area. In the "stream mode" a continuance of placements of coordinate pairs may be input.

Not a kit, the HIPAD™ comes complete with both RS-232-C and parallel interfaces and has its own built-in power source. The origin is completely relocatable so coordinates may be positive or minus for a true reference value and oversized material may be input by simply resetting the origin.

### Accurate positional information, free form sketches, even keyboard simulation

All can be entered using the multi-faceted HIPAD™ digitizer. Its capabilities and low price make the UL listed HIPAD™ a natural selection over keyboard entry, inaccurate joysticks, or expensive approximating light pens. It's perfect for inputting isometric drawings, schematics, X-rays, architectural drawings, business graphs, and many other forms of graphic information, as well as creating your own graphics.

### Use it with Apple II™, TRS-80 Level II™, PET™ or other popular computers

The HIPAD's™ built-in RS-232C and parallel 8 bit interfaces make it all possible. (For Apple II order DT-11A, for TRS-80 or PET order DT-11). Furthermore, you get English or metric scaling, data format (Binary/BCD/ASCII), selectable baud rates, and resolution of either .005" or .01".

*For complete information, contact Houston, Instrument, P.O. Box 15720, Austin, Texas 78761 (512) 835-0900. For rush literature requests, outside Texas call toll free 1-800-531-5205. For technical information ask for operator #5. In Europe contact Houston Instrument, Rochesterlaan 6, 8240 Gistel, Belgium. Phone 059/27-74-45. Telex Bausch 81399.*



The ideal input device for the small system user.



Available with stylus or optional cursor.



Available with optional display.

™ HIPAD is a trademark of Houston Instrument  
TRS-80 is a trademark of Tandy Corporation  
APPLE is a trademark of Apple Computer Inc.  
PET is a trademark of Commodore Business Machines Inc.

Circle 48 for literature.  
Circle 49 to have a representative call.

INSTRUMENTS & SYSTEMS DIVISION  
Together...we'll create tomorrow.

BAUSCH & LOMB

\*U.S. Suggested retail price

# MODEM \$129<sup>95</sup>

No other acoustic modem gives you all these features at this low price.



The MFJ-1232 Acoustic Modem gives you a combination of features, quality and performance that others can't match at this price.

0-300 Baud, Bell 103 compatible. Originate/Answer. Half/full duplex. RS-232, TTL, CMOS level compatible. Use any computer. Cassette tape recorder ports save data for reloading or retransmission. 6 pole active filter handles weak signals. Carrier detect LED indicates adequate signal strength for data recognition. Quality "muffs" gives good acoustic coupling, isolates external noise for reliable data transfer. Crystal controlled. "ON" LED. Aluminum cabinet. 110 VAC or 9 volt batteries. 9x1 1/2x4 in.

Apple II, II Plus: software and cable for modem, MFJ-1231, \$39.95. Plugs into game port. No serial board needed.

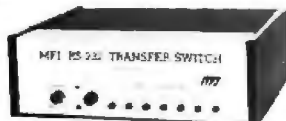

It's like having an extra port

\$79<sup>95</sup>

MFJ-1240 RS-232 TRANSFER SWITCH. Switches computer between 2 peripherals (printer, terminal, modem, etc.). Like having extra port. Push button switches 10 lines (pins 2,3,4,5,6,8,11,15,17,20). Change plug or cable to substitute other lines. Push button reverses transmit/receive lines. LEDs monitor pins 2,3,4,5,6,8,20. PC board eliminates wiring, crosstalk, line interference. 3 RS-232 25 pin connectors. 7x2x6 in.

## \$99<sup>95</sup> MFJ-1108 AC POWER CENTER.

Adds convenience, prevents data loss, head bounce, equipment damage. Relay latches power off during power transients. Multi-filters isolate equipment, eliminate interaction, noise, hash. Varistors suppress spikes. 3 isolated, switched socket pairs. One unswitched for clock, etc. Lighted power, reset switch. Pop-out fuse. 3 wire, 6 ft. cord. 15A, 125V, 1875 watts. Aluminum case. Black. 18x2 3/4x2 in. MFJ-1107, \$79.95. Like 1108 less relay. 8 sockets, 2 unswitched. Other models available, write for free specification sheet.



Order from MFJ and try it. If not delighted, return within 30 days for refund (less shipping). One year unconditional guarantee.

Order yours today. Call toll free 800-647-1800. Charge VISA, MC. Or mail check, money order. Add \$4.00 each for shipping and handling.

CALL TOLL FREE ... 800-647-1800

Call 601-323-5869 in MS, outside continental USA

**MFJ ENTERPRISES, INCORPORATED**

921 Louisville Road, Starkville, MS 39759

(and therefore expensive in terms of personnel time, etc.). Microcomputers can be used to allow individuals to practice lessons independently and at their own speed.

Learning that involves manipulation, such as might be found in chemistry, physics, and other sciences, presents another problem area. Here, microcomputers and computer-aided instruction can allow an individual to manipulate and explore ideas, concepts, figures, etc., in structured but flexible ways. Such programs can allow severely physically disabled individuals to handle "flasks" and "chemicals" on the TV screen and carry out experiments and manipulations that would otherwise be beyond their direct control.

Another whole area for microcomputers in education would be their use not as direct teaching aids but as aids in providing fundamental facilities necessary for a meaningful and effective education. Examples of these aids for a "normal" individual might be eyeglasses or a pencil and paper. The need to see, read and write, take notes, and do independent work are of course necessary capabilities for receiving an education within our current system. The severely physically disabled individual who has no ability to use a pencil and paper, to take notes, to write, or to do independent work is at an extreme disadvantage. Microcomputer-based writing systems designed to provide the same flexibility as a scratch pad and pencil could be used to provide these individuals with the capabilities for appropriate and adequate participation in their educational programs.

Finally, microcomputers can be used to teach fundamental programming skills. Because of the many ways in which microcomputers can aid individuals with disabilities, and because of the direction in which many aspects of the employment world are heading, it is quite clear that microcomputers hold future vocational potential for disabled individuals, whether their vocational direction is in the computer field or not. Computer literacy and the ability to reconfigure or oversee the reconfiguring of computer systems to

meet their changing needs may be extremely important capabilities for disabled individuals to have.

**Communication aids:** Because of the nonportability of microcomputers up to now, their use has been limited mostly to work-station types of applications. These applications include computer-aided writing and filing systems as well as work-station phone control and phone communications using the new speech-output capabilities. However, the stationary systems have not been able to meaningfully address the conversational needs of individuals with severe speech impairments.

The recent introduction, though, of portable and hand-held computers is opening up the potential for microcomputers to move out of the stationary writing-aid category and begin to address the categories of portable writing/note-taking aids and conversational communication aids. Because of the fine motor control required, these portable units will find their greatest initial application for individuals having mild to moderate physical disabilities. When used as components within systems having other input techniques, however, they may also be used by individuals having more severe disabilities. The limited memory, I/O (input/output), and control capabilities of these systems are currently hampering their application in many areas. In time, the memory capabilities may greatly expand, but the I/O and control capabilities are generally not emphasized in a portable unit and may continue to present problems for awhile.

The major barrier for using microcomputers as communication aids, however, is the need for custom interfacing to achieve optimum speed. This usually involves the development of special interfaces not commercially available. As I will discuss in more detail later, the use of custom hardware in conjunction with standard computers can negate many of the advantages of using a microcomputer in the first place. Care must be taken, therefore, when making a decision between an adapted microcomputer and a specially designed aid to solve problems in this area.

# Anadex SILENT SCRIBE™ printers. Quietly going about your business.



Now and then office noise levels can go sky-high. But with Silent/Scribe – our new family of matrix impact printers – you can raise your printer expectations while significantly lowering your office noise level.

How quiet is "silent"? Silent/Scribe operates at less than 55 dBA, which means that in the average office you may have to look at it to determine whether it's printing.

Also standard are sophisticated communications controls and protocols, flexible and easy-to-use operator controls, quick-change continuous loop ribbon cartridge, and universal interfaces that work with virtually any computer system.

For full details on how Silent/Scribe can fit your application – quietly – contact Anadex today. You'll find the units attractively packaged, quality engineered, modestly priced, and available now.

SILENT/SCRIBE MODELS						
Standard Features	DP-9000A	DP-9000B	DP-9000C	DP-9000D	DP-9000E	DP-9000F
Printing Speed (Chars per Sec.)	10	150	150	120	120	200
	12	180	180	—	—	120
	12.5	—	—	150	150	—
	13.5	200	200	—	—	—
	15	—	—	180	180	150
	16.4	—	—	200	200	184
Enhanced	10	—	—	—	—	100
Expanded Print (Double Width)	Yes	Yes	Yes	Yes	Yes	Yes
Dot Addressable Graphics (Dot/in, HV)	60/72	60/72	75/72	75/72	72/72	—
Max. Line Width (in.)	8.0	13.2	8.0	13.2	13.2	—
Audible Alarm	Opt	Opt	Opt	Opt	Opt	Yes
Out-of-Paper Sense	Yes	Yes	Yes	Yes	Yes	Yes
Ribbon, Continuous Loop Cartridge (Yds)	30	30	30	30	30	—
Interfacing:						
Parallel Cent. Comp	Yes	Yes	Yes	Yes	Yes	Yes
RS-232-C Serial	Yes	Yes	Yes	Yes	Yes	Yes

And Silent/Scribe is as easy to buy as it is to live with. You can select a variety of printing speeds, fonts and line widths. Some models provide both draft and enhanced quality copy. All models have superb dot-addressable graphics at no extra cost.



©Copyright 1982  
Anadex, Inc.



DP-9000A



## Silent/Scribe. The Quiet Ones from Anadex.

ANADEX, INC. • 9825 De Soto Avenue • Chatsworth, California 91311, U.S.A. • Telephone: (213) 998-8010 • TWX 910-494-2761  
U.S. Sales Offices: San Jose, CA (408) 247-3933 • Irvine, CA (714) 557-0457 • Schiller Park, IL (312) 671-1717 • Wakefield, MA (617) 245-9160  
Hauppauge, New York, Phone: (516) 435-0222 • Atlanta, Georgia, Phone: (404) 255-8006 • Austin, Texas, Phone: (512) 327-5250  
ANADEX, LTD. • Weaver House, Station Road • Hook, Basingstoke, Hants RG27 9JY, England • Tel: Hook (025672) 3401 • Telex: 858782 ANADEX G

Rugged, simple, dependable.

## RCA Interactive Data Terminals as low as \$236\*...



Reliable, portable RCA VP 3000 series Interactive Data Terminals feature: video and audio output; color-locking circuitry for sharp color graphics and rainbow-free characters; reverse video; tone and noise generator; 20 and 40 character formats; resident and

programmable character set; LSI video and microprocessor control. All have a unitized 58-key, 128 character keyboard with flexible membrane switches, plus the features of the ASCII keyboards below.

**VP 3501 Videotex Data Terminal.** (Shown) Built-in RF modulator and 300 baud direct-connect modem. Ideal for time sharing data base applications. Works with standard TV or monitor. Also has expansion interface and 16-key calculator keypad. As low as \$265.\*

**VP 3303 Interactive Data Terminal.** Similar to VP 3501, without modem or calculator keypad. Has selectable baud rates and RS232C/20Ma current loop interfaces. As low as \$246.\*

**VP 3301.** Same as VP 3303, without RF modulator. As low as \$236.\*

## ...and RCA ASCII Encoded Keyboards as low as \$49.\*

RCA VP 600 series ASCII keyboards feature: flexible membrane keys with contact-life over 10 million operations; unitized keyboards are spillproof, dustproof with finger positioning overlay and positive keypress; 2-key rollover circuitry; tone feedback; high noise immunity CMOS circuitry; 5V DC operation and 58-key, 128-character keyboard, selectable "upper case only."



**VP 616.** EIA RS232C compatible, 20 mA current loop and TTL outputs; six selectable baud rates. Standard keyboard plus 16-key calculator. As low as \$78.\*

**VP 611.** Similar to VP 616 with 8 bit parallel output. As low as \$59.\*

**VP 606.** Same as VP 616, less calculator keypad. As low as \$65.\*

**VP 601.** (Shown) Same as VP 611, less calculator keypad. As low as \$49.\*

To order, or more information, call toll-free 800-233-0094.

In PA, 717-393-0446. Or write:  
RCA MicroComputer Marketing,  
New Holland Avenue,  
Lancaster, PA 17604.

# RCA

\*OEM quantity prices.

**Information resource/management:** Disabled individuals could use a microcomputer for information resource/management in all of the same ways that able-bodied individuals can. In addition to these uses, computers can help physically or sensorily disabled individuals to access materials that would normally be difficult for them to handle in a number of ways. Sensory or, particularly, physical disabilities may prevent these persons from making effective use of notebooks, filing systems, calendars, dictionaries, phone lists, etc., due to their inability to quickly manipulate and scan these materials. Microcomputer-based systems with interfaces designed specifically to work with the individual's residual capabilities can provide effective and efficient means of paralleling all of these functions. At present, most of these applications are in the area of *user-generated* information storage and retrieval, although in some cases, such as a dictionary, materials or databases are being developed for general use and dissemination.

**Security/monitoring systems:** A major barrier to the ability of many disabled or aging persons to live independently is the lack of effective and economical means to ensure their safety and the ability to summon help. Some ways in which a microcomputer could aid in these independent living endeavors would be through the provision of mechanisms for physically disabled individuals to control the locks and windows in their homes, emergency-call systems for individuals who have difficulty in making a call or who are unable to speak, monitoring systems for persons who could fall or in some way render themselves unconscious and unable to call for help, and medication-reminder systems.

A monitoring system could run periodic checks and call for help if the individual does not respond to the system's queries. Reminder systems can be developed both to provide reminders as to when medication should be taken and to check whether certain actions necessary in the taking of the medication (e.g., opening the refrigerator) have been done. Lack of



## Microsoft's RAMCard™ with RAMDrive™ takes the whir, click and wait out of the IBM PC.

**Solid State Disk.** When you add the Microsoft™ RAMCard to your IBM® Personal Computer, you also add RAMDrive, which lets you use memory as you would normally use a disk. That gives you "disk access" that's typically 50X faster than disk. Without the whirring, clicking and waiting of mechanical data access.

**Fast and easy.** You simply designate a portion of memory as "disk." RAMDrive takes it from there, instructing the program to go to RAM rather than disk whenever data access is needed. The result is faster, smoother, no-wait computing.

**64K to 256K.** You can start small, but think big. Start with 64K and add Microsoft RAMChips™ in 64K blocks. Or, buy the full 256K now. Either way, you get both RAM and "disk" capabilities. All in a single slot.

**A complete subsystem.** The RAMCard package comes complete with the memory board (64K,

IBM is a registered trademark of International Business Machines Corp. Microsoft, RAMChips, RAMCard, and RAMDrive are trademarks of Microsoft Corporation.



128K, 192K or 256K), documentation, a diskette which adds RAMDrive and, a full one year warranty.

**More tools for IBM.** Microsoft wrote PC-DOS, the standard operating system for the IBM Personal Computer. And Microsoft is first in providing a full range of languages, applications programs and utilities for the IBM PC. The addition of RAMCard with RAMDrive is our way of saying that Microsoft will continue to offer more and better supported tools for the IBM PC.

**See for yourself.** Ask your Microsoft or IBM PC dealer for a demonstration of both main memory and disk features of the Microsoft RAMCard with RAMDrive. It's solid state memory you can also use like a disk. And it takes the whir, click and wait out of the IBM PC.

BETTER TOOLS FOR MICROCOMPUTERS

# MICROSOFT

Microsoft Corporation  
10700 Northup Way  
Bellevue, WA 98004

response to these reminders could be used as an alerting signal to the monitoring/call system, which could, in turn, summon aid.

**Cognitive and language-processing assistance:** Congenital or acquired conditions often leave an individual with impaired cognitive processing. In some cases, it is a general processing deficit, as in mental retardation. In other cases, it is a specific dysfunction of a particular process, such as short-term memory or the ability to program speech or remember names. The greatest obstacle to identifying effective applications of microcomputers in these areas is the limited knowledge about the processes and remediation methods in general. The prospect of microcomputer-based cognitive prostheses is still beyond the current state of the art but not beyond the imagination. The use of microcomputers in remediation, however, may be much closer and more realistic, especially in areas where extensive drill and practice are

associated with the remediation process.

### Providing Standard Functions

As I stated previously, it is important for disabled individuals to be able to use microcomputers for the same purposes as everyone else does. These purposes include word processing, computer games, computer-aided instruction, control (including environmental control in both the home and job site), financial planning, management, and general computing. In some cases, the disabled individual may use these standard capabilities (e.g., word processing) to help offset specific disabilities (e.g., inability to use a pencil). More and more, however, individuals need to access the standard computer programs because computers are an integral part of their education or jobs. As our society in general incorporates the use of computers into every facet of daily living, access to them is becoming more and more essential.

In order to provide disabled individuals with the ability to run standard software programs, transparent modifications that can circumvent the individual's particular disabilities need to be developed. (The word *transparent* is used here to refer to a technique that is invisible to any standard software programs—that is, modifications cannot be detected by any piece of standard software when this technique is used.) A completely transparent modification does not interfere with the standard program in any way. Similarly, the standard program cannot interfere or negate the modification. A few examples of transparent modifications may be useful here.

The simplest example of a transparent modification is a weight on a hinge that can be tipped to hold down the shift key. This mechanical modification can allow a one-handed or one-fingered (or headstick) typist to enter shift or control characters on the keyboard. There is no way for computers to tell in what manner the individuals are entering data, and any programs will run without modification.

A somewhat more flexible modification may be the use of a keyboard-emulator module, which would be inserted into the computer between the keyboard and the main computer board. Electrically, this keyboard emulator would look exactly like the standard keyboard. As a result, it would be impossible for the processor (or any software) to tell that the signals coming to it were not coming from the computer's keyboard.

The keyboard emulator would have a connector on the side that would accept RS-232C serial, parallel, or any desired signal format and inject the characters received into the computer as if they were typed on the keyboard. In this manner, persons using any one of a large number of special communication or control aids could directly control the computer as if they were typing on the keyboard.

Because the special communication aids can be custom fitted to the individual, they can be selected to optimize the individual's physical con-

Now add time-keeping capability to your RS-232C compatible computer. The Hayes Chronograph calendar/clock coordinates and logs system activities by date and time... down to the second.

The Chronograph is ideal for business or home applications. Use it with your computer for timing everything from time-sharing access... to electronic mail and lights and sprinklers.

**Hayes Stack**  
Microcomputer Component Systems

Plus Chronograph is designed to stack neatly on top of other Hayes Stack component systems -- like the RS-232C compatible Smartmodem. (Each requires a dedicated RS-232C port.)

Keep your computer system up-to-date with the Hayes Stack Chronograph. Only \$249 at computer stores everywhere. There's no better time.

**Hayes**

**The Hayes Stack™ Chronograph**  
It's time. And it's now.

Hayes Microcomputer Products Inc. 5835 Peachtree Corners East, Norcross, Georgia 30092 (404) 449-8791  
Hayes Stack is a trademark of Hayes Microcomputer Products, Inc.  
© 1981 Hayes Microcomputer Products, Inc. Sold only in the U.S.A.

# GALAXY OF FEATURES

A **GALAXY** of features makes the **LNW80** a remarkable computer. As you explore the **LNW80**, you will find the most complete, powerful, ready to run, feature-packed personal and business computer ever made into one compact solid unit.



**MODEL I COMPATIBILITY** - The **LNW80** is fully hardware and software compatible with the Model I. Select from a universe of hardware accessories and software - from VisiCalc® to space games, your **LNW80** will launch you into a new world of computing.

**FULLY LOADED** - A full payload includes an on-board single and double density disk controller for 5 1/4" and 8" single or double sided disk drives, RS232C communications port, cassette and parallel printer interfaces are standard features and ready to go. All memory is fully installed - 48K RAM, 16K graphics RAM and 12K ROM complete with Microsoft **BASIC**.

**QUALITY CONSTRUCTION** - Instrumentation quality construction sets **LNW80** computers apart from all the rest. Integrated into the sleek solid steel case of the **LNW80** is a professional 74-key expanded keyboard that includes a twelve key numeric keypad.

**HIGH RESOLUTION GRAPHICS & COLOR** - The stunning 480 X 192 resolution gives you total display control - in color or black and white. The choice of display formats is yours; 80, 64, 40 and 32 columns by 24 or 16 lines in any combination of eight colors.

**PERFORMANCE** - Lift-off with a 4MHz Z80A CPU for twice the performance. The **LNW80** outperforms all computers in its class.



Our down to earth price won't send you into orbit

## LNW Research Corp.

2620 WALNUT Tustin, CA. 92680  
(714) 641-8850 (714) 544-5744

Monitor and Disk drives not included  
TM Personal Software, Inc.



# Oryx software Quality Discount

**GUARANTEED LOWEST PRICES!** We will match any advertised price. Just show us the ad.

## APPLE

Art Sci Magic Window	\$ 79
Dos Boss	22
Utility City	25
Apple Panic	25
Teacher Plus	35
Continental CPA acctg. module ea.	210
Depreciation planner	335
Datamost Real Est. Analysis	110
Datascot Micropainter	30
<b>Denver Software</b>	
Financial partner	\$219
Pascal Tutor	108
Pascal Programmer	108
Duosoft Business Planner	265
Edu-ware compu-matic	32
<b>Ellis Computing</b>	
Nevada Cobol	\$169
Nevada Pilot	99
Nevada Edit	99
Application pkg. ea.	22
<b>Hayden Software</b>	
Datagraph	\$ 39
Histograph	25
Applesoft Compiler 3.2	180
Apple pie Series ea.	109
<b>Howard Software</b>	
Real Estate Analyzer	\$145
Tax preparer '82	127
Tax preparer state: CA,NY/NJ/IL	60

## IUS

Datadex	\$125
Easywriter	162
Easy mover	88
Easyjack (Combo)	262
Easy mailer	162

## Microfocus

Cis Cobol Std.	\$775
Forms-2	175

## MicroPro

Wordstar	\$229
Mailmerge	85
Calculator	145
Spellstar	145

## Games

Sargon II	\$ 25
Zork I or II	32
Deadline	32
Crossword Magic	18

## Misc.

Mathematic	\$ 80
Spellguard	267
Edh 6502	82
Locksmith	90
Super Screen II	108
A-stat 79	140
Mailing list	48
G. O. C. I full Acctg. system	1,890
Stoneware DB Master	179

## Muse Software

Super Text II	\$125
Address book	43
Form letter	87
Data Plot	52

## And Many More

## CPM

<b>MicroPro</b>	
Wordstar	\$235
Mailmerge	95
Calculator	199
Spellstar	160
Supersort I	170

## Microsoft

Basic 80	\$285
Basic Compiler	325
Fortran 80	345
Cobol 80	570
Macro 80	140

## Peachtree

General Ledger	\$399
Accounts Receivables	399
Accounts Payables	399
Inventory	399
Payroll	399
Property Management	799
CPA Client Write-up	799

## Star Computer System

G/L, A/R, A/P or Pay.	\$350
Legal Times Billing	845
Property Management	845

## Sorcim

Supercalc	\$225
Trans 86	115
Act	155

## Supersoft

Diagnostic I	\$ 48
Diagnostic II	83
Disk Doctor	84
Fortran	215
C Compiler	175

## TCS

GL, A/R, A/P, or Pay.	\$ 79
All modules above	265
Module Compiler	98
Inventory	95

## Ashton - Tate

D Base II	\$595
-----------	-------

## Byrom Software

8STAM	\$160
8STMS	160

## Digital Research

Pascal MT+	\$ 85
MAC	65
SD (8080 Debugger)	65
ZSD (Z80 Debugger)	90
CP/M 2.2	149
C Basic 2	97
PL/1-80	449

## And Many More

## IBM PC

Wordstar	\$285
Mailmerge	95
Easywriter II	299
Easyteller	149
Crosstalk	129
DataBase Manager	170
Mailing List	85
Yedh	165
CP/M 86	295
Write-on	110
Move II	125
Spellguard	247
East (Exec. Acctg. Sys.)	625

## Accessories/ Hardware

### Boards

Co Processors 88 card (Ap. II)	\$795
Softcard (Z80 CP/M Ap. II)	296
CPS Multifunction	178
Mountain A/D + D/A	289
CCS 12K ROM/PRDM	89
CCS A/D Converter	98
CCS Serial Asynch	149
Applescope (your Apple as an Oscilloscope)	595
Videx Enhancer I	149
K & D Enhancer	115
Dan Paymar Lower case	27
ALS Smartterm	379
ALS Z-card	269
Percom Doubler II	167
BH 3 Full View 80 (AT800)	299
BH 3 32K Memory (AT400/800)	159
BTAD DS-1 (64K, Z80, CPM for IBM PC)	599
Datamac 64K (IBM PC)	399
Videx Micromodem Chip	25
Xerox Baby Blue (IBM PC)	550
Quadram Deluxe Board (IBM PC)	495
Quadram 128K Ram (IBM PC)	495
Micrafacer 8K Printer Buffer	135
Versacard	218

### Computers

Commodore/Atari/NEC/  
Xerox  
Call for Price Information

### Monitors

Amdex Video 300	\$217
Amdex RGB Color	750
NEC 12" Hires Green	175
Sanyo 12" Hires Green	220
TECO TM - 12 GX Green	147
TECO RGB 13"	525

### Modems

Novation Apple-Cat II	\$350
Hayes Smartmodem	225
Micromodem II	319
Chronograph	199

### Printers

Amdex 9500 Series	\$1,580
Epson	\$Call
Diablo 630	2,200
NEC 3530	1,890
NEC 8023A	525
Okidata Microline B2A	635
Okidata Microline B3A	790
Prism 80 (w/ 4 options)	1,177
Prism 132 (w/ 4 options)	1,705
Smith-Corona TP-1	750

### Disk Drives

Rana Elite I (Ap. II)	\$339
Rana Controller (Ap. II)	110
Micro Sci A35 (Ap. II)	399
Micro Sci A40 (Ap. II)	385
Micro Sci A70	540
Micro Sci Controller (Ap. II)	98
Tandon TM-100-1	299
Tandon TM-100-2	389

## And Many More

One Stop Shopping at  
Guaranteed Lowest Prices

trol and communication rate. One individual might be using a "brow switch" and a special scanning display. Another individual could be using a light-beam headpointer. Still another might use Morse code or some other encoding system that requires the individuals simply to look at the characters they want on a display.

The outputs from these displays would then be fed into the keyboard emulator and then into the computer as "input from the keyboard." Such an arrangement would be completely transparent and allow these individuals to utilize any software controlled from the keyboard. (Game-paddle emulators can also be used to access other programs.)

In order to allow use of the computer in its normal fashion, most keyboard emulators also accept input from the keyboard and pass it along to the computer as well. Thus, with the keyboard emulator in place, the computer can be used in the standard way by disabled individuals.

Equipping one or more computers in a classroom with such keyboard emulators would allow disabled individuals with special communication aids to access and utilize the same educational programs and courseware as the other members of their class or school. Similarly, if a company had a terminal with an emulator installed, the terminal would be usable by disabled as well as able-bodied personnel without any modification to the company's systems or software. Because the module plugs in between the keyboard and the processor, it can also be removed at any time (and the keyboard plugged back into its normal slot) for testing or maintenance of the computer or terminal. Smart keyboard emulators can also be plugged into themselves to run self-diagnostics.

Another transparent modification deals with output rather than input: a special audio screen is connected to the computer's bus; instead of creating a video image, however, it has a special flat tablet that lies on the table beside the keyboard. As blind individuals move the cursor around on the tablet, they can cause the tablet to

Write for our Free Catalog

**ORDER TOLL FREE - Outside WI - 1-800-826-1589**

- Please:**
- Wisconsin residents - add 5% sales tax
  - Add \$3.50 for shipping per software and small items. Call regarding others.
  - Foreign - add 15% handling charge. Shipping extra.

- We welcome:**
- Visa, Mastercharge - (Add 4%)
  - Checks (Allow 1-2 weeks for clearing)
  - COD (Add \$1.50 per shipment)

For technical information & in Wisconsin: 715-848-2322

**Oryx Software** • 205 Scott St., Dept. AG • P.O. Box 1961  
Wausau, WI 54401





Microcomputer Business Industries Corporation

presents

# Two Practical Peripherals For Your Apple™ II



\*Recommended  
Retail Price

## Appletime™ Clock Card

\$9900\*

- Fully Mountain Computer Software compatible
- Disk included with all software
- Includes Datebook™ - a complete desk calendar
- Time of day
- International time-keeping ability
- Calendar date
- Recharging battery backup
- Day of week
- Complete software formatting
- Program timer
- Offset time/date/day readout

## VIP™ Card - "Versatile Interface Peripheral"

(Available for EPSON, NEC, C-ITOH, IDS PRISM, OKIDATA and other graphic printers soon.)

## VIP™ G- The Ultimate Graphics Card

\$11900\*

- A Centronics Parallel Interface and Cable featuring:
- Text and graphics screen dump routine
- Graphics with inverse & emphasized modes

- Enlarged picture mode
- Variable line length with left & right margins
- Block graphics
- Chart Recorder Mode
- 90° picture rotation
- Upgradable to VIP™ G+

## VIP™ G+

has all the features of the VIP™ G plus:

- A serial port with full RS232 capability
- Software baud rate control from 110 to 9600 baud

\$14900\*

## VIP™ P

an interface card featuring:

- Two parallel ports
- Upgradable to VIP™ SP

\$11900\*

## VIP™ SP

an interface card featuring:

- Two parallel ports
- One serial port

\$14900\*

## VIP™ Graphics Diskette

\$1995\*

for the person who already owns a parallel interface and cable. Features:

- Full VIP™ I software capabilities
- Plus side-by-side twin picture capability
- Self-documentation

# MBI™

Microcomputer Business Industries Corporation

Suite 200 • 1019 8th Street

Golden, Colorado 80401

(303) 279-8438 TWX: 910-934-0191

National and international  
dealer inquiries welcome.

read out the words or letters their hands are "over." In this fashion, blind people can easily scan the screen and have it read off the contents in any random order they desire. Because they can move their hands around on the tablet, they can also get a "special feel" for the information. Because it is impossible for the main computer (or its software) to tell that this system is in place or in use, any software that uses the video display and pronounceable characters can be used by the blind individual. Thus, an individual would be able to access and use most standard software without modification.

It's obvious, of course, that programs that use a video display are designed for individuals who can see. The screen presents information to the user in a parallel format—that is, the information on the entire page is presented to the user at one time. Blind individuals using the above modification would be able to "see" the screen only a word or a character at a time. This would be equivalent to sighted persons trying to read and make sense out of words on a screen by looking at the screen through a soda straw (a character at a time) or a small tube (a word at a time). Although they could figure out what the screen said, the effectiveness of the visual display is decidedly decreased, and the organization and presenta-

tion of much of the information on the screen may be far from optimum for this type of "serial" input.

For this reason, programs written specifically for use by blind individuals use considerably different strategies for organizing and presenting information. Thus, although the audio-screen technique just described does provide access to standard software for blind individuals, it does not give them *equivalent* access to that of sighted individuals; nor does it give

---

**The audio-screen  
technique doesn't  
give the blind  
equivalent or even  
optimum access.**

---

them *optimum* access. Unfortunately, the software that has been optimized for use by blind individuals is an extremely small fraction of the software generally available. It is likely we will see the amount of this software increase with little improvement in quality. As a result, such non-optimum approaches as the audio screen will play an increasingly important role.

In the design of aids for the disabled, insights into the practical aspects of using special modifications (such as that gained by the tube

analogy above) can provide programmers with a much better understanding of the problems they are trying to solve and can lead to design of much more effective special modifications.

### Semitransparent Modifications

Hardware intervention is almost always necessary to achieve full transparency. Hardware intervention ensures complete transparency but comes at a higher cost. As a result, a number of strategies, termed *semitransparent*, have also been developed to work with some but not all software.

Some of these techniques take the form of special software routines that are hidden in infrequently used portions of memory. Vectors within the operating system are reset to cause the computer to access special pointers instead of the normal keyboard-servicing routines. These pure software routines are often loaded from disk into the computer just prior to loading the standard program. In some cases, the routines may be automatically loaded when the computer is turned on. The individual can then use the special routine to select and run other programs.

The major drawback to modifications of this type is that they usually rely on pointers that may often be reset when more sophisticated or complex programs are loaded into the

# The A2-3D1 Graphics Family...

**professional graphics  
for you  
and your Apple II.**

**subLOGIC**

Communications Corp.  
713 Edgebrook Drive  
Champaign, IL 61820  
(217) 359-8482  
Telex: 206995



Map of the University of Illinois campus constructed with A2-GE 1 and A2-3D2.

"Apple" is the registered trademark of Apple Computer Inc.

# THE BEST GETS **BETTER!**



Available NOW!  
ComboPlus with  
Real-Time-Clock  
as shown Model MR-128SP

- Fully field upgradeable**
- 64K-256K Parity Checked Memory**
- Parallel Printer Port (IBM compatible)**
- Real-Time-Clock (MS-DOS support standard, CPM/86 support available)**
- Async Com. Port (IBM compatible)**

Other products available for IBM PC: 1) 2780/3780 Bisync Emulation package; 2) Advance Com. card - Async, Bisync, SDLC, HDLC; 3) Expansion parity memory - 64K-256K; 4) Disk++ (memory, Async & disk host adaptor); 5) Original Memory Combo; 6) Async Communication Card - (1 or 2 ports); 7) Wire Wrap Card (13.1" X 4"); 8) Extender Card.  
Ask for AST products at your local Computerland stores.

**AST**  
**RESEARCH INC.**

Circle 3 on inquiry card.

2691 Richter Ave., Suite 104, Irvine, CA 92714 (714) 540-1333

Dealer Inquiries welcome



WANG

apple

ZENITH

hp HEWLETT  
PACKARD

IBM

# Look Who Picked the Peach. Did You?

They did.

And perhaps you did too. If you own an IBM Personal Computer,<sup>™</sup> an Apple III,<sup>™</sup> a Zenith Z-89<sup>™</sup> or a Hewlett-Packard HP-87,<sup>™</sup> you've had the chance to pick Peachware.<sup>™</sup> All these companies chose Peachtree Software<sup>™</sup> to get the most out of their machines for you.

And with good reason. Peachtree Software is the recognized leader in business software for microcomputers, with a reputation for comprehensive, well-designed packages, easy-to-use documentation and Peachcare<sup>™</sup> — our own array of support services unmatched in the industry.

With integrated systems like the Peachpak<sup>™</sup> 8 Accounting Series — General Ledger, Accounts Payable, Accounts Receivable, Sales Invoicing, Inventory Control and PeachPay<sup>™</sup> Payroll — Peachtree offers the manager unprecedented control over his critical accounting activities. And the Peachpak 9 Office Productivity Series, based on the PeachText<sup>™\*</sup> word

processor and including the PeachCalc<sup>™</sup> Electronic Spreadsheet, Spelling Proofreader, Mailing List Manager and Telecommunications, expands the power of Peachtree Software to all areas of the office.

Those qualities made our software the natural choice of these big manufacturers. But they're not the only ones who've picked a peach. So have tens of thousands of individual users of the better CP/M<sup>™</sup> — compatible microcomputers.

If you haven't picked the Peach, isn't it about time you did?

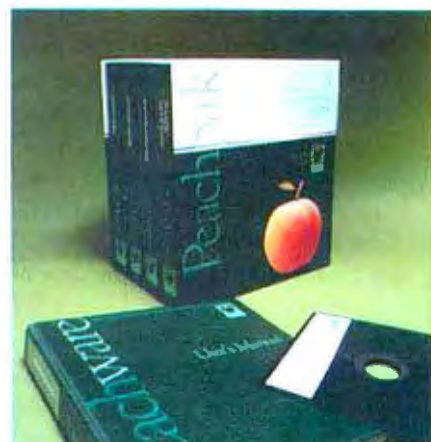

Circle 367 on inquiry card.

\*We improved Magic Wand,<sup>™</sup> and it's so good we put our name on it.

IBM is a trademark of International Business Machines Corp.

Apple III is a trademark of Apple Computer Inc.

Z-89 is a trademark of Zenith Corporation.

HP-87 is a trademark of Hewlett-Packard Company.

CP/M is a trademark of Digital Research Inc.

Peachware, Peachtree Software, Peachcare, Peachpak, PeachPay, PeachText and PeachCalc are trademarks of Peachtree Software Incorporated, an MSA Company.

Copyright © 1982 Peachtree Software Incorporated, an MSA Company.

Please send me information on Peachware<sup>™</sup> by Peachtree Software.

BY 982

Name: \_\_\_\_\_

Company: \_\_\_\_\_

Address: \_\_\_\_\_

City: \_\_\_\_\_ State: \_\_\_\_\_ Zip: \_\_\_\_\_

I am a:  prospective dealer  user of software

Peachtree Software Incorporated an MSA company

3445 Peachtree Road, N.E. / 8th Floor / Atlanta, Georgia 30326 / (404) 266-0673



computer. In addition, many of the more advanced programs consume all of the available memory space, totally wiping out such special programs. In some cases, special programs can be hidden in ROM (read-only memory), and special strategies can be incorporated that allow them to continually retake control of the computer even while more complex programs are being run. However, this approach again requires the use of at least some special hardware.

Examples of purely software modifications are the programs written by Peter Maggs at the University of Illinois, Champaign-Urbana (see reference 1) to provide a voice output of video-screen contents (using a variety of speech synthesizers). An example of the ROM-based approach is the adaptive-firmware card developed by Paul Schwejda for the Apple II (see "Adaptive-Firmware Card for the Apple II" by Paul Schwejda and Gregg Vanderheiden, page 276; see also reference 2). In the case of the

adaptive-firmware card, the modification is essentially transparent to most programs except those that have critical timing loops around keyboard input routines (the adaptive-firmware card "steals" the microprocessor during these periods).

The SHADOW/VET voice-entry terminal for the Apple (by Scott Instruments) is another example in this category. The SHADOW/VET allows total control of the Apple using voice commands. Except for programs that involve critical timing loops around input routines, the SHADOW/VET can be used instead of the Apple keyboard for all operations even inside protected programs such as Visicalc. (Some keyboard use is necessary during initial voice programming of the unit.)

### Multilevel Program Processing and Multitasking

In addition to the transparency problem, designers must understand two other concepts that are important

to the development of many micro-computer-based assistive systems, particularly for extremely motor-impaired individuals. The first concept, *multilevel program execution*, refers to the ability of programs to be stacked so that the output of one program serves as the input to the next (for example, a special one-switch input program feeding a communication/spelling acceleration program feeding a standard text editor or other standard program). *Multitasking* refers to the ability to jump back and forth between different programs while keeping all programs active in memory in the computer at the same time (see reference 3).

The need for multilevel program execution stems from practical constraints in the development of programs for disabled individuals. If you had unlimited funds and time, you could develop a single program which contained all of the following:

- input routines (one-switch scanning, Morse code, optical headpointing, etc.)
- acceleration techniques (abbreviation expansion, word/phrase capability, word prediction, etc.)
- function programs (text editing, spreadsheet programs, games, educational programs, etc.)

Similarly, if all of the software were to be written by one group at one university (or company or rehabilitation center), then the software could be written in compatible modules that could simply be linked together to form the configuration desired by a given individual. Because neither of these proposals is practical, especially in light of the extreme variety of programs and functions that would be required on the third level, some type of program nesting is going to be required.

The need for multitasking can best be seen by first imagining an average person sitting at his desk, working on a problem, when the phone rings. He turns and answers the phone. The caller, a colleague, is asking for information for a project she's working on. While on the phone, the person pulls out a file, runs off some calcula-



## SAVE OVER 25% ON YOUR PC UPGRADES

### ANATRON MULTIFUNCTION RAM BOARD 64 KB Standard **\$450**

Socketed for easy memory expansion • Each port individually disabled  
Parallel Printer Port may be configured as LPT1 or LPT2 or LPT3

- Two RS 232 ports configured as COM1 and COM2
- Base address selectable on any 64 KB boundary
- All features fully compatible with IBM PC

#### EVERYTHING FOR THE PC

HARDWARE	SOFTWARE
<ul style="list-style-type: none"> <li>• Disk Drives:               <ul style="list-style-type: none"> <li>Single Sided [160 kb] ..... \$239.00</li> <li>Double Sided [320 kb] ..... \$305.00</li> </ul> </li> <li>• RAM Expansion Packages for               <ul style="list-style-type: none"> <li>Mother Board [16 kb] ..... \$25.00</li> <li>Memory Expansion Board [64 kb] ..... \$130.00</li> </ul> </li> <li>• Printers [NEC, EPSON, OKIDATA] ..... \$CALL</li> <li>• Monitors [NEC, TEKO, AMDEK] ..... \$CALL</li> <li>• Diskettes [3M <small>single sided double sided</small>] ..... \$CALL</li> <li>• Extension Cables for:               <ul style="list-style-type: none"> <li>Printer ..... \$CALL</li> <li>Monitor [two cable set] ..... \$CALL</li> <li>Keyboard ..... \$CALL</li> </ul> </li> </ul>	<ul style="list-style-type: none"> <li>• Condor DBMS</li> <li>• Ed-Word<sup>2</sup> Screen Editor/Word Processor</li> <li>• Rat TRAX [color screen dump utility]</li> <li>• NECPRINT [NEC 8023AC print utility]</li> </ul> <p style="text-align: center; margin-top: 10px;">More hardware and software coming. Call for details.</p>

## AEGIS SYSTEMS

P.O. Box 401      202 West Bennett Street, Saline, Michigan 48176      1-800 521-0521  
 Terms FOB Saline      Michigan [313] 429-2678

# IS THIS LEVEL OF RELIABILITY REALLY NECESSARY?

## ACCUTRACK



If you've ever lost data due to a faulty disk, you know how important reliability can be.

That's why Accutrack disks are critically certified at 2-3 times the error threshold of your system. Why they're precision fabricated for higher signal quality, longer life and less head wear. And why we take such extra steps as testing single-density mini disks at double-density levels. So you don't have to worry about the reliability of your media.

Accutrack disks. OEMs have specified them for years. You can trust them for your data. Call toll-free (800) 225-8715 for your nearest dealer.



**ACCUTRACK**  
Dennison KYBE Corporation

82 Calvary Street, Waltham, Mass. 02254  
Tel. (617) 899-0012; Telex 94-0179  
Outside Mass. call toll free (800) 225-8715  
Offices & representatives worldwide

Circle 156 on Inquiry card.

**Dealers:** Give your customers a choice—Accutrack's OEM performance as well as your heavily advertised brand. We have the industry's only complete line of disks, cassettes and mag cards, including virtually all special formats. If you want a quality line, small minimums, the ability to mix and match, private labeling, fast delivery and great price, call today. Find out how responsive a media supplier can be.

# VICTORY AT C.



## The Z-80 C Cross-Compiler Fleet has arrived.

Is your Z-80 C object code larger than it needs to be?  
Rerouting to assembler because C isn't fulfilling its promise?

Your ship has come in. Vandara introduces the Z-80 C Cross-Compiler. Starting with the finest "pure" C-to-8080 cross-compiler available (Whitesmiths), we've added 8-bit expressions, a right calling convention, a peephole optimizer and full use of the Z-80 instruction set to reduce your code size by up to 36%.

And if you're in a ROM-based environment, you'll appreciate our in-line machine code, listings, ROM-able tables and optional royalty-free runtime library!

The Vandara Z-80 C Cross-Compiler is currently available for VAX, PDP-11 and ONYX hosts.

For more information call  
206) 542-7611 or write VANDATA  
17544 Midvale Ave. N. Suite 205,  
Seattle WA 98133



tions, and makes some notes based on feedback from his colleague. He then hangs up and goes back to his writing.

A severely physically disabled individual who uses an assistive micro-computer-based system would need a multitasking capability to accomplish this. First, he would have had to suspend what he was doing (without destroying it or waiting to update and store it) before answering the phone. While on the phone, he would need to access his information system, use his writing system to make notes, and use some computing capability before hanging up the phone and reentering the program he had suspended as the phone rang. During the process, he would need to enter and exit from several programs and routines without losing his place in any of them, thus requiring multitasking.

As with the multilevel program, this problem would not exist if it were possible to write a single, all-encompassing program for each individual. The program could then be written to allow suspension of activity and jumps from one section to another. This approach, however, would not allow the individual to take advantage of any of the standard software constantly being written and updated. It would also deny him access to the programs being used by his peers, as well as programs that may be necessary for him to access as part of his education or employment.

### Approaches to the Multilevel and Multitasking Problem

Although current microcomputer operating systems do not allow multilevel and multitasking activities, more sophisticated operating systems are continually being developed. With the increasing memory and processor capabilities of the newer generations of microcomputers, designers can begin to consider the development of special versions of operating systems specifically designed to allow these types of multilevel and multitasking operation.

If the systems were configured to look like one of the many standard operating systems from the outside, they could in fact run standard pro-



# Boldly Go Where No Drive Has Taken You Before



**TAKE YOUR APPLE II® TO THE LIMIT** with a Fourth Dimension Super Drive™ — the totally compatible 5¼" drive that takes your system farther, faster . . . with read/write electronics so advanced that reading errors are virtually eliminated . . . with a track zero microswitch that keeps boot and track access smooth and quiet . . . with the ability to read half-track software and up to 143,360 bytes of DOS 3.3® . . . with similar performance on DOS 3.2.1®, Pascal®, or CP/M® operating systems. And, the disk enclosure mates perfectly with APPLE cabinetry. Suggested retail price: \$329.00 (dealer quantity discounts available).

\*utilizes Siemens 100-5 mechanics

**TO TAKE YOUR SYSTEM EVEN FARTHER** — Fourth Dimension Systems now offers these other APPLE®-compatible products:

- Switch selectable 35/80 track Dual Super Drive™. Available soon, 12 megabyte capacity drive.
- 16K RAM card
- Parallel printer interface
- Z80 card
- 80 x 24 video card

Call or write for specifics and pricing information.

**EXTENDED WARRANTY** — Fourth Dimension Systems offers a 12-month parts and labor warranty at no cost to you.

**FOURTH  
DIMENSION SYSTEMS**

#### EXCLUSIVE DISTRIBUTORS:

Advanced Computer Products, 1310 "B" E. Edinger, Santa Ana, CA 92705 (714) 558-8813  
Electronics Associates, 5808 Lord Harrison Ct., Virginia Beach, VA 23464 (804) 420-2361  
Floppy Disk Services, Inc., C.N. 5212 Princeton, NJ 08540 (609) 771-0374

**CONTACT:** Fourth Dimension Systems, 3100 W. Warner Avenue, #7/Dept. 1, Santa Ana, CA 92704 (714) 850-1228

APPLE, APPLE II, DOS 3.2.1 and DOS 3.3 are registered trademarks of Apple Computer, Inc. Pascal is a trademark of UCSD. CP/M is a registered trademark of Digital Research, Inc.

# THE ULTIMATE CORDLESS PHONE

- Have you ever felt "tied down" to the phone in your office, or at home ... expecting that important call?
- How many times have you made a mad dash for the phone ... only to find it's stopped ringing?
- And what about those occasions when you were simply too far away to hear it ring?

**Compare Our Price  
and Quality**

**Only \$189<sup>00</sup>**

(includes shipping & insurance)

## INTERSTATE PHONE REMOVES THE CORD

... and you have **freedom of phone movement** like never before! Your phone goes where you go! Take it from room to room — anywhere in your office. Take a break in the patio, pool or garden. Work way out in the garage, basement or driveway. The Interstate Phone is there at your side.

## EXTENDED RANGE

Here is truly the ultimate in cordless phones. The Interstate Phone has unbelievable sound fidelity — with an extended range of up to 600 feet. The entire unit — 10.5 ounces — attaches lightly and easily to a belt, or slips into a pocket. Yet you can receive or place calls to any corner of the world.

## YOU OWN IT

The Interstate Phone is wholly independent of the phone company. Even its installation. FCC registered and U.S. Government approved for direct connection to any existing phone jack. Installation and monthly charges are eliminated.

## STILL MORE FEATURES

The Interstate Phone unit includes everything you need: Phone • base station • compatibility with all rotary or pushbutton systems • easy installation with standard phone jacks.



## MEMORY SYSTEM

The last number called is stored in the memory and is **automatically redialed** — just push **one** button — great to reach forever busy numbers — saves redialing a string of codes.

## BATTERY RECHARGING CORD

Still another Interstate Phone **exclusive!** A great new way to keep your phone charged — with no need to return it to its base unit. A **charge cord** is provided, to plug into any AC outlet in the house. Which means the base can be tucked permanently out of sight AND the phone is anywhere you want it — being charged.

**GUARANTEE** satisfaction is completely guaranteed! Use the Interstate Phone for 15 days in your office, or home. Not pleased? You owe nothing — not even an explanation. Just return for complete, prompt refund. Please note: Equipment used for business purposes is tax deductible. You have everything to gain, and nothing to lose (in fact, you'll wonder how you ever got along without one).

YES The Cordless telephone is the sound answer for me  
Please send me \_\_\_\_\_ units at only \$189.00 each  
(California residents, please add 6% sales tax)  
Total \$\_\_\_\_\_ enclosed.

NAME \_\_\_\_\_

ADDRESS \_\_\_\_\_

CITY \_\_\_\_\_ STATE \_\_\_\_\_ ZIP \_\_\_\_\_

SEND TO: INTERSTATE TELEPHONE  
18210 Sherman Way, Reseda, Ca 91335

grams along with special-function programs. At present, such "super operating systems" do not exist. Moreover, it would take a fairly high-capacity machine to successfully implement such a system. The bulk of the microcomputers being secured and supplied for disabled individuals today are of the much more limited variety. In addition, the software that the disabled individuals must access for their education or employment is also implemented on computers that do not have multilevel and multitasking capabilities. An alternate approach therefore is required that can be implemented now with the existing systems.

## A Dual Central Processing Unit Approach

Although a true multilevel, multitasking capability is not currently possible on smaller computer systems, a reasonable approximation of one can be achieved using dual, nested computers. In this configuration, one computer would be used for the input and information acceleration programs as well as some special-function routines. A cable would connect this first computer to the keyboard (or keyboard emulator) on a second computer. The second computer would be used to run the standard software programs (the function-level programs).

Because the first computer would control the second computer through a keyboard emulator, any standard software programs could be run on the second computer without modification. At first glance, using two computers appears to be a brute-force solution; it is, however, the most flexible and straightforward method for dealing with many of the problems—and, in most cases, the *least expensive*.

Because the function-level programs would run on a separate computer, they would not require modification and could be written in any fashion and in any language. Because the entire first computer would be available for these programs, they could be written in a high-level language, thus lowering the cost to develop these special programs. Modifi-

cations of these special programs for specific individuals would be much easier, and complex input routines and data structures could be used to optimize the specific user's control and rate of input. This approach would also be much easier to modify and adapt over time to match the individual's changing abilities and needs (see reference 4).

If two identical computers were used in a dual, nested computer approach, the user would have a built-in hardware backup capability. If either computer went down, the other could be put into the input-level position. If the input-program package included some basic-function capabilities, the user would have at least a rudimentary system that could be used during the repair of the faulty computer or component.

It is more likely, however, that the two computers would not be identical. The system is designed so that the two computers do not need to be the same make, brand, model, or size. As a result, the first computer could be implemented on an inexpensive computer selected to provide only the capabilities necessary for the "first-computer" functions. This computer could then drive a much more expensive computer, which would be selected based upon the standard software programs the individual wanted to use.

In fact, the first computer could actually be used to control several different second computers in different environments (an Apple II at home, an IBM at work, and an Atari 400/800 when playing games with friends). In one system being developed at the Trace Center, University of Wisconsin, an Atari computer is being programmed to function as a high-speed, screen-based, optical, headpointing input system with abbreviation expansion and dictionary lookup capabilities. The system can then feed into a wide range of second computers (including IBM, Apple, and Radio Shack) using keyboard-emulator modules. In one case, the first computer (the Atari 400) costs less than many of the interface cards or accessories for the second computers. No matter which com-

puter is chosen, the software availability for the first computer is not important, because it will be running only the special input routines. It is the second computer that would be selected to match the standard software packages desired by the disabled individual.

### Conclusion

Microcomputers are providing existing rehabilitation engineering programs and firms with valuable new tools in the development of specialized communication techniques

and aids. They are also opening up the rehabilitation engineering field to an entirely new group of individuals (programmers, etc.) who previously were unable to directly contribute due to the high overhead required in parts and equipment. Whereas work on custom electronic aids usually required that an individual be part of a research team at a center, practical solutions can now be created with little or no hardware components other than the standard microcomputer system and accessories. This is particularly true for special-function

# Mightier than Both



## THE BENCHMARK® Word Processor

- NOW AVAILABLE ON IBM-PC.
- WORD PROCESSING TO MEET THE MOST EXACTING DEMANDS.
- MEETS HIGH VOLUME DEMANDS.
- EASY TO USE FOR THE BEGINNING USER, YET THE MOST FUNCTIONAL WORD PROCESSOR.
- ALSO AVAILABLE ON MOST MAJOR MICROS.

FEATURES: • Horizontal Scroll • Math • Footnotes • Sophisticated Boilerplate Assembly with Auto Variable Filling • Phrase library permanently stored on disk • Column Manipulation • Hyphenation • Graphics

Take a closer look at this outstanding word processor, and you will see why VICTOR, NECIS, ECS and HARRIS have all chosen the mightiest of them all... The BENCHMARK Word Processor.

For more information on this package that fits most all major micros including the IBM-PC and the new 8086/88 computers, please call or write to:



Metasoft Corporation,  
711 East Coltonwood,  
Suite E, Casa Grande,  
Arizona 85222 Tele-  
phone (602) 836-6160.

The BENCHMARK is a registered trademark

Dealers and OEM Inquiries circle 294. All other Inquiries circle 295.

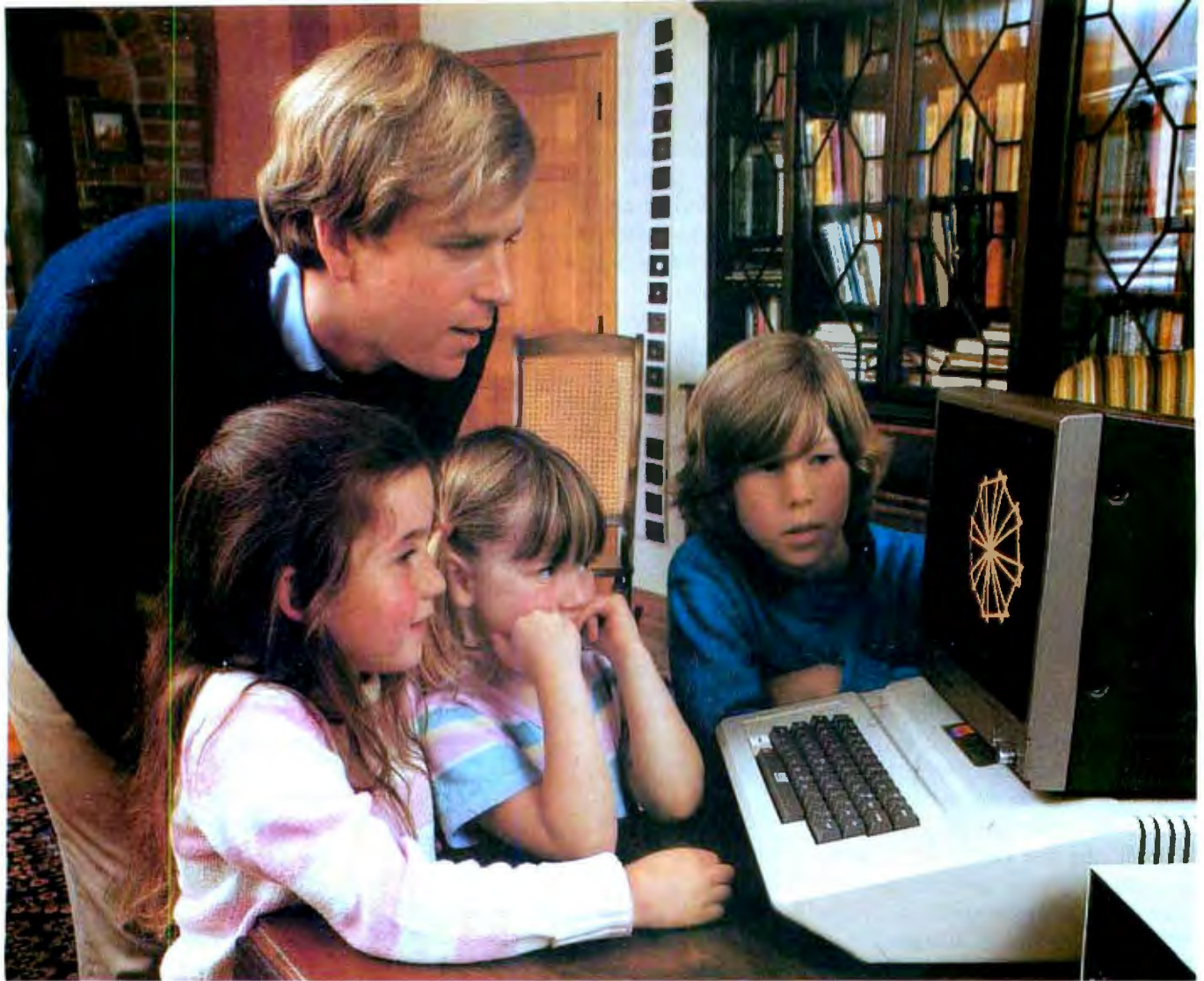

## Learning with Logo makes Logo come alive at home or in school

*Learning with Logo* is the ideal introduction to Logo for children and adults. Written for children between the ages of ten and fourteen, the book is also perfect for parents and teachers who want to learn Logo from the ground up or to use this unique language with children. Many of the projects and activities in the book were originated by children.

The book starts from the absolute beginning with detailed information about the Logo system and basic commands for controlling the Logo turtle. Dozens of introductory turtle design suggestions offer each learner a way to create projects that are uniquely his or her own, while later chapters map out a rich universe of mathematical explorations in turtle geometry.

The second half of *Learning with Logo* goes beyond turtle graphics to present a set of interactive computer

games, quiz programs, and language activities that introduce the learner to more advanced programming concepts.

Special sections throughout the book highlight the powerful ideas contained in each activity and warn about common bugs and pitfalls. For adults, "Helpers' Hints" explain important concepts more fully and offer practical teaching suggestions.

The book features detailed instructions for creating a Logo Procedures Disk (also available directly from the author) that contains sample programs and a number of "tool procedures" needed to carry out the projects in the book.

*Daniel Watt has been involved in education as a curriculum developer, elementary school teacher, teacher trainer, and researcher. He worked for five years on a series of Logo research and development projects as a member of the MIT Logo Group. At present he is an editor with BYTE Publications and*

*contributes regularly to Popular Computing and BYTE magazines.*

*Learning with Logo is written specifically for users of the version of Logo developed at MIT for the Apple II\* and distributed by Terrapin, Inc. and Krell Software, Inc. It contains appendices for users of Apple Logo\* and TI Logo\*.*

**Learning with Logo**  
Spiral-bound  
ISBN 0-07-068570-3  
230 pages  
\$12.95



Please add \$1.00 per book for postage and handling.  
Available Oct. 1982

**CALL TOLL-FREE 800-258-5420**

**BYTE/MCGRAW-HILL BOOKS**  
70 MAIN ST,  
PETERBOROUGH, NH 03458

title	#	amount
<i>Learning with Logo</i>		
<i>Logo for the Apple II</i>		
<i>Apple Logo</i>		
<i>Inversions: A Catalog of Calligraphic Cartwheels</i>		
<i>Microcomputer Operating Systems</i>		
<i>Microcomputer Disk Techniques</i>		
<i>Ciarcia's Circuit Cellar</i>		
<i>Ciarcia's Circuit Cellar Vol. II</i>		
<i>Ciarcia's Circuit Cellar Vol. III</i>		
<i>Word Processing Primer</i>		
<i>8086/8088 16-Bit Microprocessor Primer</i>		
<i>Apple Backpack: Humanized Programming in BASIC</i>		
<i>TRS-80 Graphics for the Model I and Model III</i>		
<i>sub total</i>		
<i>please add \$1.00 for postage and handling or \$2.00 per book for UPS or 1st class</i>		<i>shipping total here</i>
<i>method of payment</i>		<i>total</i>
<input type="checkbox"/> VISA <input type="checkbox"/> MC <input type="checkbox"/> check or money order enclosed		
<i>card #</i> _____	<i>expires</i> _____	
<i>ship to:</i>		
<i>name</i> _____		
<i>address</i> _____		
_____		
_____		
<i>city</i> _____		
<i>state</i> _____		<i>zip</i> _____

**BYTE|McGraw-Hill Books**



NO POSTAGE IS  
NECESSARY  
IF MAILED  
IN THE  
UNITED STATES

---

**BUSINESS REPLY CARD**

FIRST CLASS

PERMIT NO. 18

PETERBOROUGH, NH

---

POSTAGE WILL BE PAID BY ADDRESSEE

*BYTE/McGraw-Hill Books  
70 Main Street  
Peterborough, NH 03458  
USA*



# LOGO: Language of the 80's



**Apple Logo** and **Logo for the Apple II** introduce you to a dynamic new computer language that not only enables educators to make full and innovative use of the teaching potential of modern computers but also offers programmers an easy-to-use system of considerable power.

Readers of this book will see that the designers' vision of Logo as a virtually unlimited educational tool has now become a reality. Logo enables even young children to use the computer in rewarding, self-directed projects, while at the same time providing sophisticated users with a powerful and expressive general programming system. This book presents the reader with a complete guide to the exciting applications of this unique procedural language.

The author introduces programming techniques through Turtle Geometry—a series of fascinating exercises involving both Logo programming and geometric concepts. Later chapters illustrate more advanced projects that utilize Logo's sophisticated list-processing capabilities; these include the conversational

**DOCTOR** program with its simulated psychotherapist and an **INSTANT** program with which parents and teachers can create a programming environment for preschool children. The book also contains reference material of enduring value to sophisticated users.

Get in on the ground floor of the burgeoning Logo movement with this comprehensive, detailed guide to the up-and-coming computer language of the Eighties!

This book is published in two versions: **Apple Logo** is for users of Apple Logo™ software (distributed by Apple Computer Company) and contains an appendix for users of TI Logo™. **Logo for the Apple II** is specifically for users of Logo software developed at MIT for the Apple II computer (distributed by Krell Software and Terrapin, Inc.). **Logo for the Apple II** also contains appendices that enable users of Apple Logo™ and TI Logo™ to carry out the projects in the book. Be sure to specify **Apple Logo** or **Logo for the Apple II** when ordering!

**Apple Logo**  
\$14.95  
240 pages,  
softcover, illustrated

**Logo**  
\$14.95  
240 pages,  
softcover, illustrated

**ORDER TOLL FREE**  
**800-258-5420**

 **BYTE Books**  
70 Main St.  
Peterborough, N.H. 03458

programs developed to meet specific needs of disabled individuals.

The problem of providing transparent access to microcomputers (and thus allowing access to the vast world of standard software) usually requires some type of hardware intervention. With the advent of keyboard emulators and the use of dual, nested computers, even this activity promises to be returned soon to the more readily accessed and duplicated world of software. As a result, the immediate future promises to be an extremely exciting and productive period, which will see rapid advances in the development of both special-function programs and new strategies to ensure the complete access by disabled individuals to the world of microcomputers.

If this access can be assured, then the functional disabilities currently experienced by these individuals should decrease markedly as our society moves more and more into the electronic information age. If we

fail to ensure access to our computer and information-processing systems for disabled individuals, our progress into the electronic information age will instead only present new barriers.

With good communication among the new group of individuals entering this field, the existing rehabilitation personnel, and most important, the disabled individuals themselves, the amount of truly useful software can be maximized and many existing barriers reduced. It may even be possible to effectively eliminate some disabilities in the same way that eyeglasses have eliminated what would otherwise be a visual handicap for many of us. A possible example of this would be the elimination of the writing handicap currently experienced by many persons with mild to moderate manipulative difficulties (due to a physical disability or severe arthritis) through the development of very effective and portable text-editing systems. Although initially writing speed

might be slower, the incorporation of abbreviation expansion and other acceleration techniques would increase speed and give the added benefit of perfect penmanship. ■

#### References

1. Maggs, Peter and Visek, Dianna. "The Apple Computer as a General Purpose Vocational Aid for Blind Users," *Proceedings, Fourth Annual Conference on Rehabilitation Engineering*, Washington, DC, 1981.
2. *Proceedings, First Annual Computer Search for Handicapped Individuals*, Johns Hopkins University, 1981.
3. Vanderheiden, G. V. "Practical Application of Microcomputers to Aid the Handicapped," *Computer*, January 1981.
4. *Proceedings, Fourth Annual Conference on Rehabilitation Engineering*, Washington, DC, 1981.

#### Further Reading

*The Bulletin of Science and Technology for the Handicapped*

American Association for the Advancement of Science  
1515 Massachusetts Ave.  
Washington, DC 20005

*Closing The Gap*

(newspaper on computers and the disabled)

Budd Hagen, Editor  
Route 2, Box 39  
Henderson, MN 56004

*Communication Outlook*

Artificial Language Laboratory  
Michigan State University  
East Lansing, MI 48824

*COPH Bulletin*

Congress on the Physically Handicapped  
101 Lincoln Park Blvd.  
Rockford, IL 61102

*International Software Registry of Programs Written or Adapted for Handicapped Individuals*

Trace Research and Development Center  
314 Waisman Center  
University of Wisconsin  
Madison, WI 53706

*Link and Go*

(Includes COPH Bulletin above)  
2030 Irving Park Rd.  
Chicago, IL 60618

## TeleVideo Users!!

Imagine: Single key commands for WordStar™, dBase II™, Basic,.... anything!!

TVSet allows the function keys on your 802 or 950 to be automatically programmed when you startup your computer and then reprogrammed as you run different software packages.

Here's How It Works

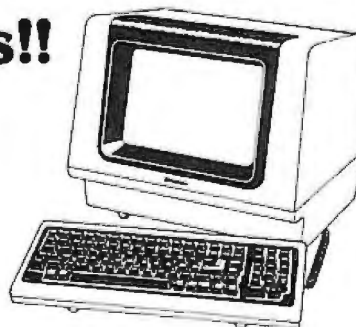

### FIRST

TVSet guides you through clear, easy-to-use menu displays to enter your custom function key contents and terminal features. 22 function keys and over 10 terminal features can be set.

### SECOND

TVSet saves the custom setup in a file for fast (even automatic) re-programming. You can have different setup files for different projects. And TVSet can read the file back in to make later changes.

### THIRD

Using a unique, FAST technique, TVSet can attach your custom function key setup to any program - like WordStar™. When that program is run the function keys are automatically set - in less than 1 second!!



**NEW  
GENERATION  
SYSTEMS, inc.**

2153 Golf Course Dr.  
Reston, Va 22091  
(703) 476-9143

**TVSet: \$75.00** CP/M or MP/M (8080/280)  
VISA/MC/COD

Foreign Orders Add \$10

**Order Line: 800-368-3359**

TM • CP/M - MP/M Digital Research • WordStar MicroPro • dBase II Ashton-Tate



# NEC's NEW ADVANCED PERSONAL COMPUTER GIVES CHARLIE THE BLUES.

If you're a businessman shopping for a personal computer, take a look at NEC. Our APC™ Advanced Personal Computer has better price/performance than any personal computer on the market.

It's a totally solutions-oriented system, supporting both CP/M-86™ and MS-DOS™ developed to solve business problems in the simplest, most cost-effective way possible.

Our business software has been optimized to take advantage of the APC's unique hardware features. That makes system operation faster and easier.

Our software includes a full set of general accounting packages, word processing, mailing list management, business planning, database management, and communications. And we're readying many more.

We back our software with a unique unconditional guarantee. It will work or you get your money back.

Our APC comes with more information storage capacity than any system in its price range.

Our high-resolution color graphics run circles, arcs and lines around everybody else. The APC's screen images—lines, characters, pictures—are unprecedented in their clarity.

See for yourself how much better we are. The solutions-oriented Advanced Personal Computer from NEC. Return the coupon to NEC Information Systems, Inc., 5 Militia Drive, Lexington, MA 02173.

PC Magazine's Best Personal Digital Processor  
 PC Magazine's Best Personal Computer  
 APC is a trademark of Nippon Electric Co., Ltd.

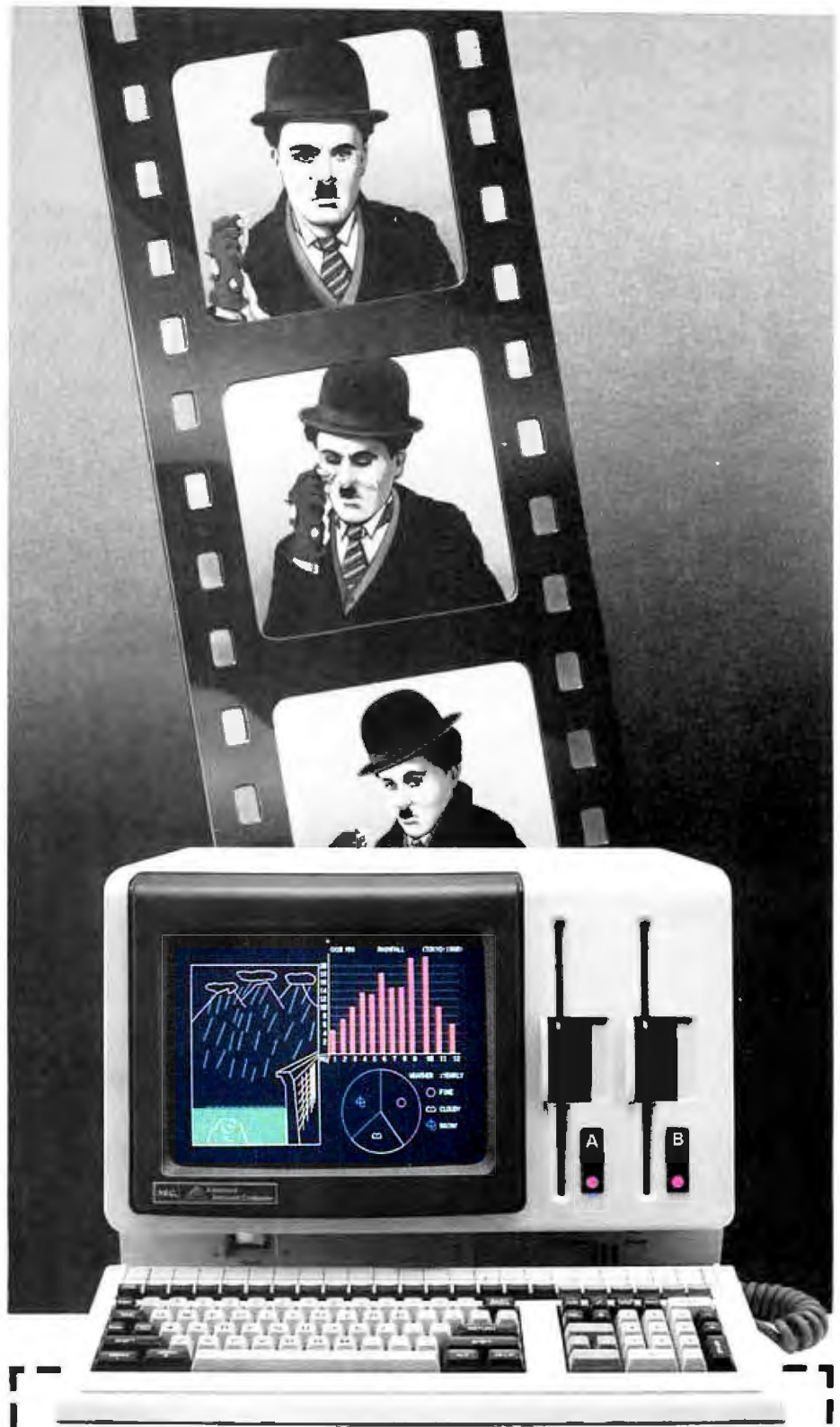

Send me more information  
 on the Advanced Personal Computer

**NEC**  
**NEC Information Systems, Inc.**  
 5 Militia Drive, Lexington, MA 02173

Name \_\_\_\_\_

Address \_\_\_\_\_

Title \_\_\_\_\_

City, State, Zip \_\_\_\_\_

Company \_\_\_\_\_

Telephone \_\_\_\_\_

BE982

**The Benchmark in World Class Computers**



FRANKLIN **ACE** 1000



# THE BEST DEAL IN TOWN!

## THE FRANKLIN **ACE**1000

You just can't beat an ACE. Especially the Franklin ACE 1000. It's the professional personal computer with all the trump cards—it costs less, it includes 64K of RAM, upper and lower case, a numeric pad and VisiCalc<sup>®</sup> keys, all features not found on the Apple<sup>®</sup> II.

Peripherals that work with the Apple II will work with the Franklin ACE 1000. Programs that run on the Apple will run on the ACE. Totally Apple compatible . . . yet, so much more!

The Franklin Ace 1000—price, power, quality, reliability—the best deal in town. Call or write today for the name of your local authorized Franklin dealer.



**FRANKLIN**  
COMPUTER CORPORATION

7030 Colonial Highway  
Pennsauken, NJ 08109  
609-488-1700

Circle 200 on inquiry card.

Franklin ACE is a trademark of Franklin Computer Corporation  
Apple is a registered trademark of Apple Computer Inc.  
VisiCalc is a registered trademark of Visi Corp.



# A New Horizon for Nonvocal Communication Devices

## *Using the Panasonic Hand-Held Computer As a Personal, Portable Speech Prosthesis*

---

Patrick Demasco and Richard Foulds  
Tufts-New England Medical Center  
171 Harrison Ave., Box 1009  
Boston, MA 02111

---

Perhaps the greatest potential of personal computers is for people with severe physical disabilities. The power, flexibility, low cost, and availability of these machines make them natural tools for people whose physical limitations restrict their activities.

In this article, we will describe how to use the new Panasonic Hand-Held Computer (HHC) as a personal and portable communication device. We have focused on its use by individuals who have expressive communication impairments due to physical disabilities. Expressive communication includes all of the methods we use to make known our needs, concerns, and creative thoughts. The most ob-

vious is the power of speech—something which most of us use as our primary means of communication. Other expressive skills, such as handwriting and typing, come into play as well.

Typical of those who may have communication impairments are large numbers of people with cerebral palsy. This form of brain damage oc-

---

**Single-purpose communication devices are effective but very costly.**

---

curs around the time of birth and results in a lifetime disability. A smaller group of people are communication-impaired as a result of amyotrophic lateral sclerosis (ALS, commonly known as Lou Gehrig's disease), which is a progressive neurological disease. Those who have suffered a stroke in the brain-stem area may also have communication impairments.

In general, these people often cannot produce intelligible speech or legible handwriting. But it is important to note that communication impairments are not a reflection of

cognitive abilities. Each of these people has normal linguistic and intellectual capabilities.

### **Alternative Communication**

A great deal of work on behalf of people who have communication impairments has been done over the last decade, and several well-designed devices have been marketed for their use. Recently, the Apple II and the TRS-80 computers have been put to use as aids for the physically impaired. The growing interest in communication devices is undeniable; in the Johns Hopkins First Annual Search for the Application of Personal Computers and the Handicapped, 27 of 99 entries dealt with communication-device concepts.

A moderate number of dedicated, single-purpose communication devices have been built. These are typically microprocessor-based with some form of printout and display, and possibly a synthesized voice. Sizes, weights, and battery-life of the devices can be tailored to the needs of the disabled to aid in portability. They can be packaged to fit on a wheelchair and to withstand tests of rugged and continuous use.

But these devices have drawbacks as well. Their cost is necessarily high. Low-volume production cannot

---

### **About the Authors**

*Patrick Demasco is a research engineer at the Rehabilitation Engineering Center at Tufts-New England Medical Center. Richard Foulds is Assistant Professor of Rehabilitation Medicine and Director of Rehabilitation Engineering at Tufts-New England Medical Center.*

---

### **Acknowledgment**

*The work in this paper has been supported at the Rehabilitation Engineering Center under Grant #G008200044 from the National Institute of Handicapped Research of the U.S. Department of Education.*

---

# Which Spreadsheet lets you:

- Use every cell  
(never see "out of memory")
- Consolidate multiple spreadsheets
- Split the screen as often as you want

VisiCalc . . . . . NO  
SuperCalc . . . . . NO  
CalcStar . . . . . NO  
**ScratchPad . . . . . YES**  
**The Ultimate Spreadsheet**



## ScratchPad features include:

- Virtual Memory (never see "out of memory")  
Every cell on the spreadsheet can be used. Don't be misled, other spreadsheets tell you how "big" the matrix is, but you can only use a very small portion. With ScratchPad's virtual memory feature you can use EVERY CELL!
- Consolidation (not just merging but also combining spread-sheets) This makes ScratchPad almost three dimensional.
- Unlimited Screen Splitting
- If/Then
- Merge
- Unlimited Title Locking
- Long Strings Supported
- Help file
- Variable column width
- Built in financial functions

- Built in math functions
- Variable formats
- Automatic and selective recalc
- Interface to Stats-Graph graphic package
- More

For virtually all CP/M, CP/M-86, and MS DOS compatible systems, including the IBM PC.

Available from fine dealers everywhere, or directly from SuperSoft.

Requires:	44k
ScratchPad:	\$295.00
Manual Only:	\$ 15.00

Japanese Distribution:  
ASR Corporation International  
3-23-8, Nishi-Shimbashi, Minato-Ku,  
Tokyo 105, Japan  
Tel. (03) 437-5371  
Telex. 0242-2723

CP/M is a registered trademark of Digital Research. VisiCalc is a registered trademark of Visi-Corp. SuperCalc is a registered trademark of Sorcim. CalcStar is a registered trademark of Micropro.

# SuperSoft®

FIRST IN SOFTWARE TECHNOLOGY P.O.Box 1628 Champaign, IL 61820 (217) 359-2112 Telex 270365



**Photo 1:** The Panasonic Hand-Held Computer (HHC) along with some of the available accessories. The HHC is in the lower right. Clockwise, the accessories are the I/O driver, the RS-232C port, the additional 8K-byte RAM module, and the video/television adapter.

possibly compete with the economics of large-run production. Distribution and service present additional problems. Products with limited use cannot support extensive field-service or local-service organizations. Repairs are often done at a central location that may be inconvenient for many users.

The personal microcomputer with its widespread availability offers an interesting alternative to single-purpose communication devices. Software communication aids are easily distributed on floppy disks that run on existing hardware. Thus the basic hardware cost is lower because of the economics of scale. By using standard microcomputer components such as game paddles, digitizing tablets, keyboards, voice recognizers, and so on, input to the personal computer can be configured to accommodate the existing abilities of the disabled person.

The personal computer's size is one drawback; mounting an Apple II on a wheelchair is impractical. And even if you did, it consumes too much power to be battery operated. While the personal computer is an excellent tabletop communication device and teaching aid, it does not meet the

voice replacement requirement of the disabled person.

### The Panasonic HHC

An article in *BYTE* (G. Williams and R. Meyer, "The Panasonic and Quasar Hand-Held Computers," January 1981, page 34) describing the new HHC marketed by both Panasonic and Quasar stimulated our interest. The computer seemed to be a bridge between the single-purpose portable communicator and the flexible, less costly personal computer. The HHC is portable enough to qualify for wheelchair mounting and is generally available at a reasonable price.

The Panasonic HHC represents a significant advance in personal computers. The system consists of a main unit with a 6502 processor, RAM (random-access read/write memory), ROM (read-only memory) monitor, ROM sockets, keyboard, liquid-crystal display (LCD), and an external bus connector. Additionally, there are several peripherals including an RS-232C interface, RAM modules, video driver, cassette interface, printer (only recently available), and modem (see photo 1).

Two or more peripherals can be at-

tached to the main unit with the I/O (input/output) driver. If only one peripheral is used, then it can be connected directly to the main unit. You can create and run Microsoft BASIC (MBASIC) programs. The HHC can also run SNAP (a derivative of FORTH) programs. SNAP programs, however, must be written and debugged on a separate development system. The working program is then loaded into a PROM (programmable read-only memory) and executed in the HHC. The HHC's operating system is written in SNAP.

Our goal at the Rehabilitation Engineering Center at Tufts University, which focuses on technology as it relates to expressive communication, was straightforward: to see how close we could come to reproducing the valuable features of the single-purpose communication devices by using the Panasonic HHC.

### Design Considerations

Engineers working on solutions to communication problems of disabled people must, of course, work around an individual's existing physical abilities to generate communication. In many instances the disabled person has sufficient manual coordination to touch a number of keys. If 27 keys can be conveniently reached, the entire alphabet and space bar can be used to make words. If more keys can be reached, their functions can be expanded to include common words or phrases. We call this one-to-one correspondence (one key for each entry) a *direct-selection method*. It is not much different from typing. Typically, in this case, a disabled person will use one finger or a headstick (a wand attached to a helmet) rather than all 10 fingers.

Sometimes, however, the desired vocabulary exceeds the number of keys or switches that can be easily pressed by the user. In extreme cases, only one switch may be accessible. For instance, the user's only controlled movement for purposes of activating a switch may be the kick of a foot. When the user has such a limited selection capability, an alternative presentation of the alphabet and vocabulary must be found.

# Two Great Languages! Two Great Compilers!

# Ada\*

Required by the Department of Defense for all its programming, Ada is a highly structured, sophisticated language, well suited to both applications and systems programming.

SuperSoft Ada is a native code, fully recursive, two pass compiler which generates ".COM" files. While currently a subset, SuperSoft Ada supports most features of the standard Ada language.

Required by the Department of Defense for Ada copyright protection: "This compiler is presently an incomplete implementation of the Ada programming language. It is intended that this compiler will be further developed to enable implementation of the complete Ada programming language, and then to be submitted to the Ada Joint Program Office for validation."

Because of the DOD requirement, Ada is certain to become a dominant language soon. Begin learning and using Ada now with SuperSoft Ada.

(Requires: 48K CP/M)  
Ada Compiler: \$300.00  
Manual Only: \$ 25.00

**Ada and C are available for virtually all CP/M, CP/M 86, and MS DOS compatible systems.**

# C



SuperSoft "C" is a professional quality compiler suitable for any programming task. It has been transported for use on the 8080, Z80, Z8000, and 8086 families of microprocessors. We plan to transport our "C" compiler to the 68000 and other new environments as they come into use. This means you will have an easy transporting task as you grow into the next generation of microcomputers.

SuperSoft "C" supports most features of Unix version 7 "C." It produces a highly optimized code making it possible to avoid assembly language coding for most tasks. The compiler is a two pass system, with pass one producing an intermediate code, and with pass two translating and optimizing to produce the assembly code of the target computer. This makes hand optimization of critical sections possible.

C (Z80, 8080): \$250.00  
C (8086): \$500.00  
C (Z8000): \$500.00  
Manual Only: \$ 15.00

Japanese Distribution:

ASR Corporation  
3-23-8, Nishi-Shimbashi, Minato-Ku  
Tokyo 105, Japan  
Tel. (03)-437-5371  
Telex. 0242-2723

\*Ada is a trademark of the Department of Defense (Ada Joint Program Office)  
CP/M is a registered trademark of Digital Research

# SuperSoft®

FIRST IN SOFTWARE TECHNOLOGY P.O.Box 1628 Champaign, IL 61820 (217) 359-2112 Telex 270365



**Photo 2:** The Tufts Interactive Communicator, developed in 1972, was an early scanning communication device. It employed all TTL circuitry and used a dedicated 5-inch monitor to display 1024 characters.

In earlier work in our laboratory, we used the *scanning method* for a single-switch communicator. The Tufts Interactive Communicator (TIC) was a stand-alone, single-purpose device that presented the alphabet in a sequential fashion. The user faced a keyboard that had a back-lit array of seven rows of eight entries (see photo 2). The TIC highlighted the array row by row from top to bottom. The user selected a row by hitting a single switch. The TIC responded by then highlighting each entry in the row from left to right. The user hit the same switch a second time to choose an entry as it was offered. The chosen letter was then shown on an accompanying video display (32 characters by 16 lines).

### Using the HHC

In developing the HHC as a communication device, we used both the direct-selection and scanning methods. Additionally, we worked within three design constraints. We would use commercially available components. No custom-fabricated circuits would be considered in the initial work. The purchase price for the components would not exceed \$2000.

We purchased two additional pieces of hardware, a Votrax Type-N-Talk for speech output and a digitizing tablet from Houston Instrument for use as an input device. All of our programs, which were written in BASIC, shared the following elements:

---

### The purchase price for our communicator could not exceed \$2000.

---

- **User input:** Each implementation has an input handler that recognizes some action of the user as a selection.
- **Message array:** The user's responses are directed to the selection of a character, word, or phrase. The arrangement of those units is called the message array. This array is generally a two-dimensional matrix whose units can be described with a row and a column number.
- **Control selection:** In addition to those units that are part of the user's message, additional units are designed to control functions necessary for the device to operate. For exam-

ple, one unit in a system with speech output would correspond to a command to send the output to the voice synthesizer.

- **Message buffer:** When the user selects a message unit, it is stored in the message buffer. Many of the control functions (e.g., display) operate on this buffer.

- **Message output:** The message selected by the user is used to communicate with another person. Therefore, it is desirable to have a flexible output scheme that will closely imitate normal communication (e.g., speech output, printed copy).

We have developed three implementations of the HHC as a portable communication device: a scanning communicator, a direct-selection communicator using a keyboard, and a direct-selection communicator using a digitizing tablet. We will treat each of the three methods separately before returning to a general discussion.

### The Scanning Communicator

Our first effort involved duplicating the function of the TIC on the HHC through a software emulation.

We needed hardware to display the 8 by 7 array of selections and to provide a single-switch input and a way to output the user's message. We used the LCD to display the array of selections. The major drawback to this implementation is that only one row of characters can be displayed at a time. (This was not a severe limitation, as we will explain later.) We used the entire keyboard of the HHC as the single-switch input so the user can hit any key (with a few exceptions) to signify a selection.

We used two output modes. For visual output, the LCD displays the user's message. The addition of a Votrax Type-N-Talk provides synthesized speech of the user's message. The Votrax is connected to the HHC through the RS-232C peripheral. A printer would also be desirable, but that peripheral was not available to us when we wrote this article.

We used only one noncommercial piece of hardware in this configuration. Because certain keys on the



# Keep Your Computer Healthy...

with the Industry Standard in System Maintenance Programs.



## Diagnostics II

Diagnostics II is the finest set of system maintenance routines available for microcomputers. It thoroughly checks all five areas of your computer system, pinpointing hardware problems to help keep your computer in perfect working order.

The areas of your computer which are tested include:

Memory, Printer, Terminal, Disk, and CPU

In addition to being extremely thorough, every test in Diagnostics II is also "submit"-able. The output of the tests can be logged to disk for later review.

(Requires 32k CP/M)

Diagnostics II: \$125

Manual only: \$ 15

## Disk Doctor

Disk Doctor automatically recovers otherwise unrecoverable information from "crashed" diskettes. It also un-erases files.

Maybe it was a lightning storm, static from the rug, or just too late at night to be working. Whatever the cause, when the diskette "crashes" or a file is accidentally erased, valuable data or programs can be permanently lost.

Disk Doctor was designed to recover this "lost" information. It consists of five wards, each performing a specific recovery operation.

- Ward A: Verifies diskettes and locks out bad sectors.
- Ward B: Places copyable information from a "crashed" file in a good file.
- Ward C: Copies diskettes without stopping for bad sectors.
- Ward D: Un-erases files.
- Ward E: Displays a directory of recoverable erased files.

Disk Doctor was not designed for use with double sided or hard disks.

(Requires: 48k CP/M, two drives for complete operation)

Disk Doctor: \$100

Manual only: \$ 15

Available from fine dealers everywhere, or directly from SuperSoft.

Japanese Distribution:

ASR Corporation International  
3-23-8, Nishi-Shimbashi, Minato-Ku  
Tokyo 105, Japan  
Tel. (03) 437-5371, Telex 0242-2723

Diagnostics II available for virtually all CP/M, CP/M-86, and MS DOS compatible systems.

Disk Doctor available for virtually all CP/M, and CP/M-86 compatible systems.

CP/M and CP/M-86 are registered trademarks of Digital Research.

# SuperSoft®

FIRST IN SOFTWARE TECHNOLOGY P.O.Box 1628 Champaign, IL 61820 (217) 359-2112 Telex 270365



Photo 3: The HHC when used as a scanning communicator (a latter-day TIC) uses the LCD to display rows of characters. The Votrax Type-N-Talk and a Radio Shack speaker complete the communication device. A printer can also be added. (The first row of the TIC array is shown on the LCD.)

HHC should not be hit as a user switch input (e.g., the Off key), we installed a Plexiglas guard on the keyboard. This guard also prevents possible damage to the HHC and angles the computer so the user can see the display more easily. The guard is easy to build (fabrication plans are available from the Tufts Rehabilitation Engineering Center). The scanning communicator is displayed in photo 3.

The HHC scanner operates as a row-and-column scanner. Two switch closures or key presses are necessary to select a unit. The HHC displays each of the eight rows in sequential order. When the user sees the desired letter or character on the LCD, he presses a key that selects the row. The chosen row remains on the LCD and the individual letters are highlighted from left to right by the cursor. The user presses a key again to select the single desired character. At this point the selection process is complete and that letter, along with any previously generated part of the message, is displayed on the LCD. If the message exceeds 26 characters, the most recent segment of the message is displayed. Then, following a short delay, the scanning process begins again at the first row.

Scanning is, of course, an inherently slow way of selecting messages. Because a sequence must be followed, some entries are near the beginning, while others fall near the end. It takes a great deal of time to reach those near the end.

In 1973 we had addressed this problem on the TIC by arranging the letters according to their frequency of occurrence in the English language. The accepted rank order is:

space e t a o n r i s h d l f  
c m u g y p w b v k x j q z

The letter arrangement must combine the rank order with the procedure of scanning a two-dimensional array.

Because the scanner moves from top to bottom and from left to right, the upper-left entry is closest to the beginning of the scan. That entry, the first column of the first row, will be displayed more frequently during repeated scanning. The entry next to it is one step less frequent because it is in the second column, one step farther away. In this manner, we can count the number of steps to each entry in the array. If the upper left has a value of 2 steps (1 row plus 1 column), the next entry in that row has a value of 3 (1 row plus 2 col-

2	3	4	5	6	7	8	9
3	4	5	6	7	8	9	10
4	5	6	7	8	9	10	11
5	6	7	8	9	10	11	12
6	7	8	9	10	11	12	13
7	8	9	10	11	12	13	14
8	9	10	11	12	13	14	15

Figure 1: The scanning process moving from top to bottom and left to right provides faster access to certain locations. The numbers shown in this array signify the distance of each location from the start of the scan. Each time a selection is made, the scan starts over.

umns) and the third has a value of 4 (1 row plus 3 columns). The first entry in the second row also has a value of 3 (2 rows plus 1 column), and the second entry in that row has a value of 4 (2 rows plus 2 columns). By placing the value of each entry in an 8 by 7 array, we can see a pattern emerging (see figure 1).

The entries that are equally as far from the beginning of the scan are located along diagonal lines. By taking the rank order of letters in English and placing them according to the best location on the array, we can obtain an optimal arrangement for scanning a keyboard (see photo 4).

When we compared our layout to similar 8 by 7 arrays that have been arranged alphabetically or in pseudotypewriter fashion, we found our arrangement to be approximately 50 percent faster for the user.

To perform functions that are not part of the basic system operation, some of the units in the array are used as control selections. These are as follows:

*SP (Speak)*: sends the entire contents of the message buffer to the Type-N-Talk.

*DS (Display)*: displays the contents of the message buffer.

*CL (Clear)*: clears the contents of the message buffer.

*< - Back (Backspace)*: moves the message cursor back one space.

*< W (Backword)*: moves the message cursor back one word.

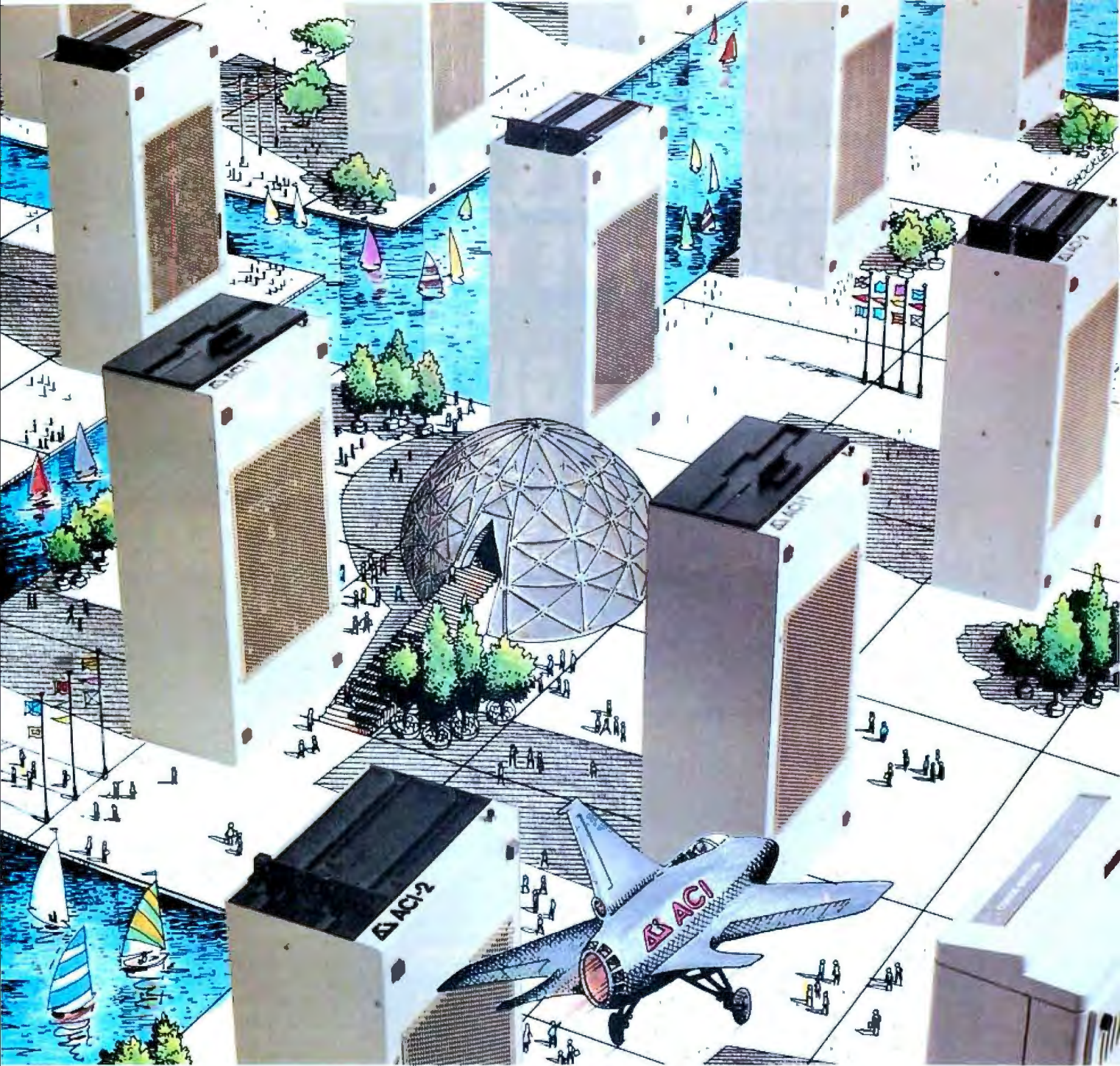

# Alspa Computers PLUS Multi-User Hard Disk



#### SMALL SIZE AND LOW COST

ALSPA full performance, CP/M computers are the smallest 8" drive micro's around. An ALSPA computer with a 4 MHz Z80A CPU, 64K of RAM, one or two 8" floppy drives, three RS-232 serial ports, one parallel port, and one hard disk port is no larger than most single add-on drives, and weighs only about 18 lbs. An ACI-1 can be yours for as little as \$1995.00 plus CP/M.

#### CORVUS\*\* INTERFACE

Standard on all ALSPA computers in a hardware interface which connects directly to either a Corvus hard disk drive or a Corvus Constellation\*\*, multi-user hard disk system. Our Corvus operation system is easy to install and use.

#### SUPERIOR PERFORMANCE

One demonstration will prove that our compact and durable ALSPA computers are designed to provide dependable, powerful computing service. Look at capability and speed and you'll agree we're the best value for the dollar.

DEALER INQUIRIES INVITED

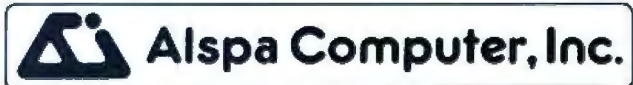

MORE THAN OUR NAME IS UNIQUE

300 Harvey West Blvd., Santa Cruz, CA 95060 (408) 429-6000

\*\*CP/M is a trademark of DIGITAL RESEARCH, INC.

Circle 20 on inquiry card.

\*\*Corvus and Corvus Constellation are trademarks of CORVUS SYSTEMS, INC.

**TO BECOME THE LEADER  
IN TERMINALS, TELEVIDEO  
HAD TO GIVE YOU MORE.**

**WE'RE STILL GIVING YOU  
MORE WITH OUR NEW  
SMALL BUSINESS COMPUTERS.**



The new TS 802 business computer.

In three short years, TeleVideo became the number one independent supplier of CRT terminals in a very competitive marketplace.

We did it by designing and building terminals with more performance, reliability, features and functions than the competition.

But at a lower price.

Now TeleVideo has entered the even more competitive microcomputer marketplace. And we intend to repeat that success with the same basic philosophy:

By providing big system performance and features. And TeleSolutions — a hardware/software package that includes word processing and financial planning software programs.

For a price lower than many of the low performance personal computers.

## TELEVIDEO'S TS 802 AND TS 802H. THE COMPUTERS THAT GIVE YOU MORE.

The TS 802 is TeleVideo's lowest priced computer.

Yet it gives you many more of the important features found only in larger computers costing much more.

- Like modular design for easier maintenance.
- High speed Z80A microprocessor with 64K bytes of RAM main memory — enough memory to handle most business applications.

- The CP/M operating system, which is included at no additional cost to give you access to more micro-computer software programs than any other operating system.

- An upward growth path through a unique multiple processor, building block architecture.

- Dual 5¼ inch double density diskettes with a million bytes of unformatted storage capacity.

- A high resolution, non-glare video screen with detached keyboard — just two examples of our innovative, ergonomic computer design.

- Two R232C serial ports for a printer and modem.



- And a high speed port for plug-in expansion to a larger multi-user, multi-tasking TeleVideo computer system.

- But suppose you need more storage. TeleVideo's next model up, the TS 802H, gives you all the same features of the TS 802. But instead of two floppy diskettes, it uses one floppy diskette and a 5¼-inch Winchester hard disk to give you 9.6 million bytes of unformatted storage capacity — nearly 10 times the storage for only twice the price of the TS 802.

## COMPUTERS THAT GROW AS YOUR NEEDS GROW.

The TS 802 and TS 802H are more than just single-user, stand alone computers.

When it's time to expand, simply plug them into TeleVideo's more powerful TS 806 or TS 816 multi-user, multi-tasking systems. The TS 802s then become intelligent, fast response satellite stations.

And because each has its own CPU, there's none of the degradation of throughput and contention for a single CPU that slows down the typical shared system. Each user maintains full processing capability in a shared file environment.

With TeleVideo, there's no obsolescence. Because of the unique multi-CPU architecture and TeleVideo's multi-tasking software, the TS 802s do not have to be replaced as your data processing needs grow.

## TELESOLUTIONS. THE SOFTWARE PACKAGE THAT GIVES YOU MORE.

Instead of offering you just a business microcomputer, TeleVideo is offering a computer and software package called TeleSolutions. And instead of

offering you just any software, TeleSolutions™

offers you the most popular, most versatile software: MicroPro's® word processing WordStar™ and business planning CalcStar™.

Whether you own a small business, manage a department in a company,

or are your organization's DP manager, the combination of TeleVideo com-

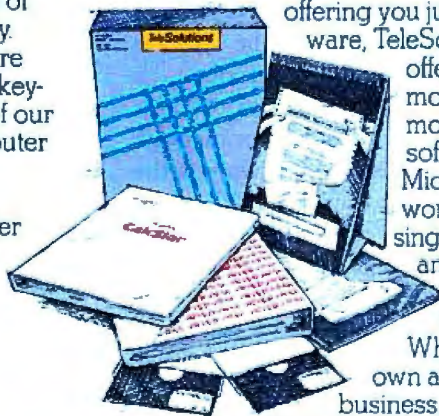

puters with WordStar and CalcStar gives you the quality text editing and financial planning help you'll need. If you do require more software, our CP/M operating system allows you to choose from the widest variety of microprocessor software.

When you buy either the TS 802 at \$3,495\* or TS 802H at \$5,995\* TeleVideo includes WordStar and CalcStar for a special price of \$500 — a savings of nearly \$300.

## WORLDWIDE SERVICE.

TeleVideo's small business computers are serviced by TRW's nationwide service network, and by distributors around the world.

## THE BETTER BUSINESS SOLUTION? PROVE IT TO YOURSELF.

Before you begin evaluating business computers make a list of what you'd like one to do for you. Then bring that list to one of TeleVideo's computer dealers throughout the world. Sit down at a TeleVideo® computer. Study the TeleSolutions Package. Even try another computer. Compare the features, the functions, and the performance.

And compare the price.

We don't think you'll find a better business solution than TeleVideo and TeleSolutions.

For details and the address of your local distributor call toll free 800-538-1780. And in California call 415-745-7760.



TeleVideo Systems, Inc.

Dept. 6108

1170 Morse Avenue  
Sunnyvale, CA 94086

Please send details on TeleVideo computers and TeleSolutions to:

NAME \_\_\_\_\_

TITLE \_\_\_\_\_

COMPANY \_\_\_\_\_

ADDRESS \_\_\_\_\_

CITY \_\_\_\_\_

STATE \_\_\_\_\_ ZIP \_\_\_\_\_

PHONE # (\_\_\_\_\_) \_\_\_\_\_

TeleSolutions™ is a trademark of TeleVideo Systems, Inc. WordStar™ and CalcStar™ are trademarks of MicroPro International Corporation. CP/M is a registered trademark of Digital Research Inc. \*Prices are suggested retail excluding applicable state and local taxes — Continental U.S.A., Alaska and Hawaii.

Circle 458 on inquiry card.

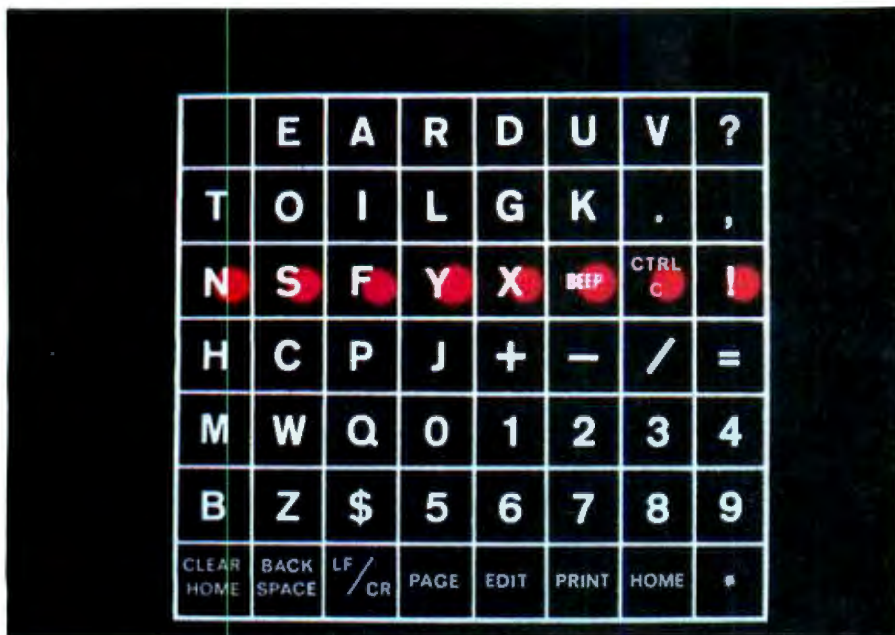

Photo 4: The optimized scanning array of the TIC is arranged according to the frequency of letters in the English language.

**SR (Scan rate):** allows the user to alter the rate at which information is displayed on the LCD. In the case of a disabled person, this control is essential to optimization of the user's performance.

**BP (Beep):** causes the HHC to make an audible beep. This allows the user to gain someone's attention easily.

The revised design we are now working on will include these improvements:

- **User programmability:** Including a user vocabulary makes a communication aid a personal device. The 8 by 7 matrix does not leave much room for user vocabulary after the basic alphabet and control commands are added. We have two alternatives: to make the array larger (e.g., 10 by 10) or to layer the scanner so that the user can switch levels. By offering a large number of selections, a programmable user vocabulary could greatly enhance the potential of this implementation.

- **External switch:** The keyboard as a switch is not an effective input scheme for every individual. Connecting an external switch through the RS-232C port (e.g., foot switch) could take advantage of the bodily

movement over which the user has the most control.

- **Anticipatory scanning:** Rather than display the same 8 by 7 matrix to the user every time, it is possible to develop a scheme in which the device offers the user a choice based on his previous letter selection(s). For example, if the user selected "Q," the device would then display "U" as the first option. (The probability that "U" would follow "Q" is high). This scheme could significantly increase the efficiency of the device for the user.

### Direct Selection Using a Keyboard

This configuration of the HHC is easy to do. Simply described, a direct-selection communicator uses the keyboard of the HHC for message entry. The necessary hardware is the HHC main unit, the RS-232C adaptor, and the Votrax Type-N-Talk. Output is through the LCD and the Type-N-Talk.

Because the keys on the HHC are much smaller and closer together than those on a conventional keyboard, we had to implement a keyguard. We designed one to fit over the HHC keyboard that would help prevent the user from making

false entries that could impede the communication rate. Initially, we attempted to use Plexiglas, but we found that the drilling necessary to make the sheet fit the square keys of the HHC was extremely difficult.

Finally, we used the telecomputing overlay that comes with the RS-232C peripheral. This is a thin vinyl die-cut overlay that fits over the keyboard and changes the legend to the equivalent of a teletypewriter keyboard. The overlay was originally designed to fit so that the keys would stick through and project above it. Our modification used 1/8-inch-thick double-stick tape placed between the rows of keys. We placed the overlay on the tape to elevate it to a level even with the top of the keys.

The HHC now has a flat surface. When a finger hits between two keys, neither key is pushed, because the overlay, supported by the double-stick tape, cannot move. When a key is hit directly, the vinyl dimples down and allows the key to be pushed. This modification provides a workable keyguard without expensive alteration.

To operate this device, users type a message at the keyboard. As they type, entries appear on the LCD of the main unit. The assignable-function keys serve as command units to enable them to output the message to the voice synthesizer and clear the message buffer. The drawback to this implementation is that the keyboard is small and many disabled individuals might have difficulty making accurate selections despite the presence of a keyguard.

### Direct Selection Using a Tablet

The usefulness of the direct-selection communicator is restricted by its small keyboard. To overcome this limitation, we decided to use a digitizing tablet from Houston Instrument as an input device.

The digitizing tablet has an 11.5-inch-square active area and outputs the coordinates of the cursor through an RS-232C port. The device has several operating modes that include single-point digitization and continuous digitization. The tablet is easily connected to the HHC with the

# Give Your Computer The Graymatter It Lacks

Graymatter Mass Storage Systems for your Personal Computer has just broken the price barrier. PLUS... an Introductory Price is being offered for a limited time that is just short of insane. IQ Systems, the manufacturer of the Graymatter, knows you have been waiting to enjoy the extensive benefits of a hard disk Mass Storage System on your computer and believes you have waited long enough for the right price and product. Now you can have:

- Faster Data Access
- Greatly Increased Data Storage
- Complete File to File Reporting
- Faster Data Processing
- And a System that Expands with You

All of this and much more at a price you will never see again in 1982. That's right, IQ Systems and your Authorized Graymatter Dealer have teamed up to offer you the deal of 1982. They're not offering you just the Graymatter 5 at the unheard of price of \$1895.00 (\$100.00 below suggested retail) BUT... they're also going to include a Transparent Adaptor Interface Kit so you can integrate the Graymatter into your system for FREE. That's right! a kit worth up to \$200.00 for FREE! An incredible

total savings of up to \$300.00 from the already lowest price Mass Storage System on the market... if you act NOW!

**Price And  
Technology  
Meet At Last!**

THIS OFFER EXPIRES ON SEPTEMBER 18, 1982

**The GRAYMATTER Coupon**

**IQ  
systems**

**graymatter  
5**

Give IQ Systems a call at 1-800-432-7257 (within California), or 1-800-854-0561 (nationwide), (toll free), ask for extension 915 and get the name and address of your local Authorized Graymatter Dealer. Clip out the coupon (you must have it to get the price) and take it to your Graymatter Dealer. Give him the coupon and get your Graymatter 5 for \$1895.00 and your FREE Adaptor Kit. If you have any trouble, give IQ Systems a call at the 800 number and after asking for extension 915 give the operator your name, phone number, and the problem you are having.

THIS OFFER EXPIRES SEPTEMBER 18, 1982

Adaptor Kits Available for Most Personal Computers  
Ask Your Dealer for a Complete List

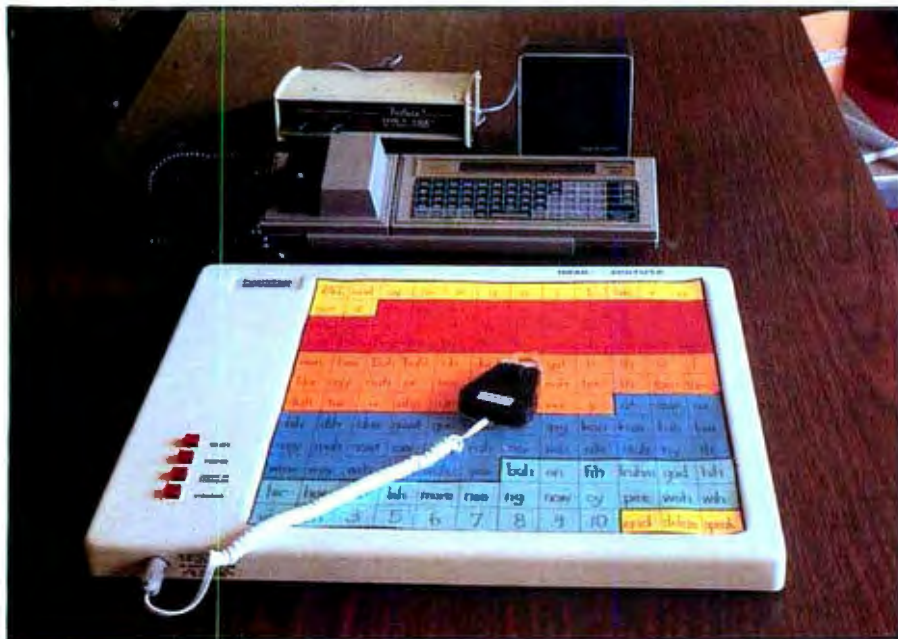

Photo 5: A Houston Instrument Digitizing Tablet is added to the HHC and Type-N-Talk to allow for an expanded and flexible keyboard.



Photo 6: Jim Viggiano, a nonvocal consumer consultant at Tufts-New England Medical Center, demonstrates his method of communicating using his index finger on the language board. The keyboard arrangement is the WRITE-400 system of language clusters.

RS-232C peripheral. Message output is accomplished by the LCD and the Votrax Type-N-Talk. This configuration appears in photo 5.

A 12 by 12 matrix of character and word selections is overlaid on the digitizing surface. To operate the tablet, the user holds the digitizer pen and touches the desired unit, which

appears on the LCD for user verification. A potential for greater communication rates exists because the user does not have to wait for the selection to appear as in the scanning system. He only has to pick it out of the array by touching the tablet. Naturally, the user of this device must have greater motor control.

Q	G	Y	Z			
U	R	I	P			
J	M	N	SPACE	E	H	W
C	O	A	T	D		
X	F	L	B			
K	V					

Figure 2: An optimized direct-selection arrangement for the alphabet using the relative frequency of letters to place them in concentric circles around the space.

We decided on a 12 by 12 arrangement, but that is only one of many possible layouts. The digitizing tablet has a resolution of 100 targets to the inch. Under software control it is possible to select layouts that include small or large targets and even arrays of targets with mixed sizes and shapes.

The same sort of array-optimization scheme that we used in the scanning method can also be used in direct selection. The typical disabled person may use only one finger or a headstick, so the standard typewriter layout is inefficient. Because a space is the most commonly used "character," it can be located in the center of the keyboard. An optimized keyboard design can be completed by arranging the characters around the space in concentric circles or squares. The more frequently used characters will be placed closer to the center. Figure 2 provides an example of this implementation for an 8 by 7 array.

The designer of any communication system must choose the characters, words, or phrases that will appear in the array. While this choice of units is dependent on many things, the most important factor is the size of the array. The scanning-communicator array was not much larger than the size of the alphabet. In the direct-selection tablet communicator the array is 144 elements, which gives us much greater flexibility in our choice of units. Instead of an alphabet and word scheme, we chose the WRITE system, developed at the Rehabilitation Engineering Center by



For top quality performance from your computer, use the flexible discs known for memory excellence. Now, buy a specially marked box of 10 Memorex® 5¼" mini flexible discs and we'll send you an additional mini disc FREE.

Features like our uniquely sealed jacket and protective hub ring make our discs last longer. And a soft inner liner cleans the ultra-smooth disc surface while in use. It all adds up to better performance and reliability.

Our proprietary high density media formulation and 100% error-free certification guarantee reliable performance in all single or double density applica-

tions. So for business, word processing, or personal computer applications, Memorex mini discs are sure to do the job. And we back them with a full year warranty to prove it.

So see your local Memorex distributor or dealer or call (800) 538-8200 (In California (408) 987-1893) today. Buy a box of 10 flexible 5¼" mini discs. Then send the coupon in the box to Memorex for your free mini disc. It's that simple.

It's a great way to improve your memory and get a big bonus in computer performance.

**MEMOREX**

A Burroughs Company

**Improve  
your memory  
by 10%.**

Dealer inquiries invited

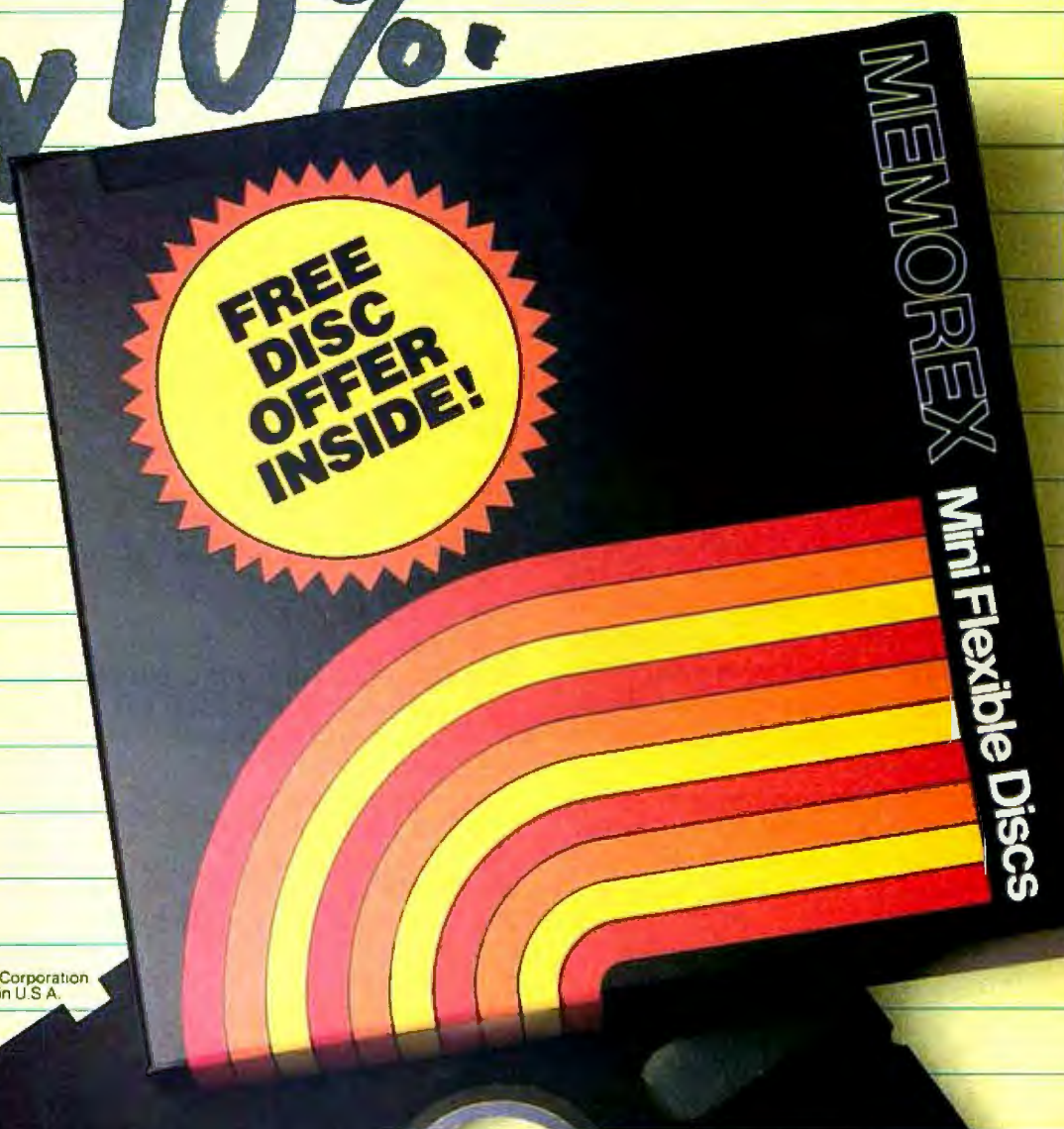

Circle 292 on inquiry card.

© 1982 Memorex Corporation  
Memorex is a registered trademark of Memorex Corporation  
Offer ends December 31, 1982. Offer good only in U.S.A.

Dr. Cheryl Goodenough-Trepagnier. It consists of a statistically derived list of the most commonly occurring letter clusters in the English language. (Photo 6 shows the language clusters on the digitizing tablet.)

The rationale for this system is that it provides a set of language units that will produce all English words by means of the lowest possible number of selections. For example, in an alphabetic system the average number of selections per word is 5; in a WRITE-400 system, the average number of selections per word is 1.54.

The control selections implemented on the direct-selection communicator include all that were used on the scanning communicator, with the exception of the scan rate.

Of the many ways to improve this system, user programmability is probably the most significant enhancement that can be made. Because the direct-selection implementation has a much larger array than the scanning communicator, an individualized user vocabulary is a more desirable feature. In addition, programmability would enable the user to select the size of the array. The array size is ultimately dependent on the user's motor-control ability. Because individual abilities vary significantly, no single configuration can optimize every user's communication speed.

### BASIC Implementation

We wrote all three implementations in the supplied MBASIC language using information from the HHC's reference manuals. (See listing 1 for the scanning configuration program.) Along the way, we discovered it was not possible to use the INPUT or GET commands to look at the keyboard because both of those commands wait for an input before proceeding to the next command. With a scanning arrangement, the display must be changing while the device waits for an input. Therefore, to implement a keyboard scanner we had to use the keyboard buffer. The keyboard-buffer pointer will change any time a key is depressed. In the program in listing 1, PEEK(518) represents the value of this pointer.

There is a major disadvantage to

Listing 1: MBASIC program for the scanning configuration of the HHC.

```

5  REM DATA FOR DISPLAY ARRAY
10 DATA " ", "E", "A", "R", "D", "U", "V", "?", "
15 DATA "T", "O", "I", "L", "G", "K", " ", " ", "
20 DATA "N", "S", "F", "Y", "X", "BP", "SR", "!", "
25 DATA "H", "C", "P", "J", "+", "-", "/", "=", "
30 DATA "M", "W", "Q", "0", "1", "2", "3", "4", "
35 DATA "B", "Z", "$", "5", "6", "7", "8", "9", "
40 DATA "CL", "<", "<W", "SP", "DS", "*", "(", ")", "
45 REM DATA FOR MESSAGE DISPLAY ARRAY
50 DATA " ", "E", "A", "R", "D", "U", "V", "?", "
55 DATA "T", "O", "I", "L", "G", "K", " ", " ", "
60 DATA "N", "S", "F", "Y", "X", "1", "2", "3", "4", "
65 DATA "H", "C", "P", "J", "+", "-", "/", "=", "
70 DATA "M", "W", "Q", "0", "1", "2", "3", "4", "
75 DATA "B", "Z", "$", "5", "6", "7", "8", "9", "
80 DATA "13", "14", "15", "16", "17", "*", "(", ")", "
85 DIM A$(8,7), B$(8,7)
90 ATTACH 70 TO #2
95 REM
100 REM EXECUTABLE CODE
105 GOSUB 555
110 REM
115 REM THE FOLLOWING CODE LOADS THE TWO ARRAYS
120 REM A$ AND B$ WITH DATA
125 FOR I=1 TO 7
130 FOR J=1 TO 8
135 READ A$(J,I)
140 NEXT J,I
145 FOR I=1 TO 7
150 FOR J=1 TO 8
155 READ B$(J,I)
160 NEXT J,I
165 REM
170 REM THE FOLLOWING CODE WILL EXECUTE A ROW
175 REM SCAN AND TESTS FOR A KEYBOARD ENTRY
180 XLAST= PEEK(518)
182 PRINT
183 PRINT BUF$
185 FOR I=1 TO 7
195 FOR J=1 TO 8
200 PRINT A$(J,I);
205 NEXT J
210 PRINT
212 IF PEEK(518)<>XLAST GOTO 240
215 NEXT I
220 GOTO 185
225 REM
230 REM THE FOLLOWING CODE EXECUTES A COLUMN
235 REM SCAN AND TESTS FOR A KEYBOARD ENTRY
240 YLAST=PEEK(518)
245 PRINT
250 FOR J=1 TO 8
255 PRINT A$(J,I);
260 FOR L=1 TO WAIT
265 NEXT L
270 IF PEEK(518,<>YLAST GOTO 315
275 NEXT J
280 PRINT

```

Listing 1 continued on page 182

# CHART SMARTS

## Computer Graphics To Get To Know Your Business Better.

**GRAFTALK IS POSITIVE PERFORMANCE SOFTWARE, DESIGNED EXPLICITLY FOR THE BUSINESS USER, THAT TURNS YOUR MICROCOMPUTER INTO A GRAPHICS STUDIO.**

A fully interactive graphics package, GrafTalk can produce a wide mix of visuals from your business data that could be vital to the efficient functioning of your day-to-day operations. Productivity reports, profit trends, budget projections, absentee reports, office expenses, sales curves—every business pattern obscured in hard figures can be projected into a visual display for your sharper review, understanding and response.

### GRAFTALK ADDRESSES THE JOB, NOT THE COMPUTER SCIENCE!

GrafTalk functions as a business tool, not a computer adjunct. You don't have to know the intricacies of computers to use GrafTalk effectively. The programming has been done. You just put it to good business use by commanding the production of the BAR, PIE, LINE OR SYMBOL charts that describe and illustrate your business activity. The job is done!

### GRAFTALK TAKES COMMANDS

...in the way YOU want to give them—in straightforward English-like language! And it takes your commands either directly from your microcomputer or from a disk file. It's your option.

Whether you are a tender foot or a veteran in microcomputer lore, you can produce sophisticated graphics with a few simple, direct commands. As your experience grows you can choose to use many of GrafTalk's more than 100 commands to accomplish a wide range of visual functions which are fully detailed in our manuals.

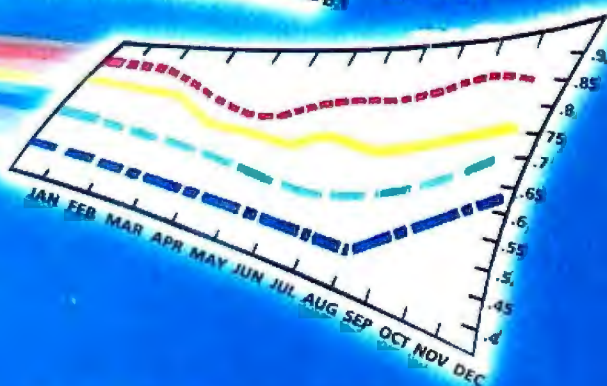
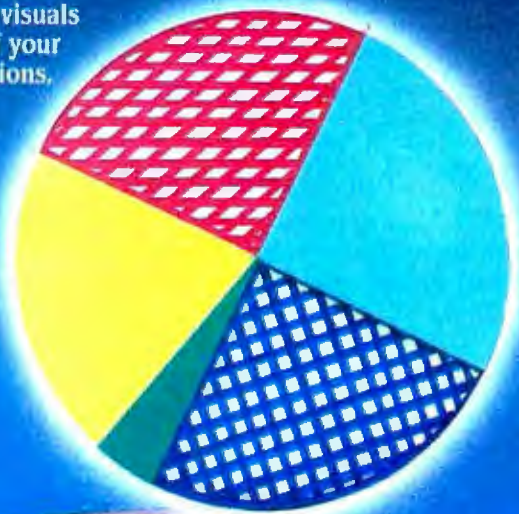

GrafTalk works with most CP/M<sup>®</sup> systems and most popular graphics devices. Also, optional full-color support is available for use with color terminals, printers or plotters.

Contact Lifeboat Associates which brings you GrafTalk and 200 other programs suitable for use in professional programming and personal environment.

CP/M is a REGISTERED TRADEMARK of Digital Research

**GrafTalk™** is a trademark of **REDDING GROUP INC.**

#1  
**Lifeboat Associates**

Lifeboat Associates  
1851 Third Avenue  
New York, New York 10028  
Tel: 717 850 0200  
TWX: 710-581-2524 (LBSOFT NYA)  
Telex: 650693 (LBSOFT NYK)

Lifeboat Associates Ltd  
PO Box 125  
London WC2H 9LJ  
United Kingdom  
Telephone: 01-636 9028  
Telex: 893709 (LBSOFTG)

Lifeboat Associates SARI  
70 Avenue D Argenteuil  
92900 Argenteuil France  
Telephone: 1 733 08 04  
Telex: 820154 (LBFRA)

Lifeboat Assoc. GmbH  
Hinterbergstrasse 9  
Postfach 251  
CH-8330 Cham, Switzerland  
Telephone: 042 36 8656  
Telex: 865265 (MICO CH)

Intersoft GmbH  
Schlossgartenweg 5  
D-8045 Garmisch-Partenkirchen  
Telephone: 089-966-424  
Telex: 521 3643 (ISOFD)

Lifeboat Inc.  
5-13-14 Shiba  
Minato-ku Tokyo 108 Japan  
Telephone: 03-456-4101  
Telex: 2423296 (LBSFYUJ)

World's foremost software source.

Circle 266 on inquiry card.

developing flexible input schemes from a BASIC-based system: the keyboard buffer is the only HHC device that can be programmed easily from that language. Unfortunately, the status of peripheral devices such as the RS-232C interface is hidden from BASIC. Because the peripheral devices lie in the same address range as the MBASIC ROM, you must switch banks to access those peripherals. This can be done only from a SNAP program.

### Realizing Full Potential of HHC

We believe communication aids can be successfully developed on the HHC through the use of SNAP. In addition to SNAP's greater accessibility to the HHC's unique memory architecture, it offers the advantage of greater execution speed and smaller memory requirements.

Although you will never be able to program directly in SNAP on the HHC, a SNAP-based development system on the market includes emulation software to run on an Apple II. This development system (available from Friends Amis Inc., 505 Beach St., San Francisco, CA 94133) allows the programmer to create and debug programs on the Apple II and then to burn PROMs that are placed inside the main HHC unit. Because the Panasonic machine does not have a disk storage system yet, PROMs are an ideal storage system.

Using a SNAP-based system would also make way for the expansion of the HHC's usefulness to the disabled individual. We are now focusing on having the HHC operate in two modes. The first mode, which has been the topic of this article, is the operation of the HHC as a personal communication device. The second mode would incorporate the three input strategies (e.g., scanning) into the actual operation of the HHC. This mode would give the disabled individual an opportunity to operate the HHC as a personal computer. This strategy clearly presents the greatest potential for using a personal computer as a rehabilitation aid and comes closest to our ultimate goal of eliminating the need for special-purpose devices. ■

*Listing 1 continued:*

```

285 GOTO 245
290 REM
295 REM THE USER HAS MADE A SELECTION
300 REM THE FOLLOWING CODE DETERMINES IF IT WAS
305 REM A CHARACTER OR A COMMAND. IF IT WAS A
310 REM CHARACTER THEN THE MESSAGE IS DISPLAYED
315 IF LEN(B$(J,I))=2 GOTO 355
320 BUF$=BUF$+B$(J,I)
325 N=N+1
335 GOTO 180
340 REM
345 REM THE FOLLOWING CODE EXECUTES THE COMMAND
350 REM SELECTIONS
355 COM=VAL(B$(J,I))-10
360 ON COM GOSUB 375,515,400,450,470,435,420
363 PRINT
365 GOTO 180
370 REM BEEP(BP) SUBROUTINE
375 FOR I=1 TO 5
380 PRINT CHR$(7)
385 NEXT I
390 RETURN
395 REM CLEAR SUBROUTINE
400 BUF$=""
405 N=0
410 RETURN
415 REM DISPLAY SUBROUTINE
425 RETURN
430 REM SPEAK SUBROUTINE
435 PRINT #2;BUF$
440 RETURN
445 REM BACKSPACE SUBROUTINE
450 BUF$=LEFT$(BUF$,N-1)
455 N=N-1
460 RETURN
465 REM BACKWORD SUBROUTINE
470 C$=RIGHT$(BUF$,1)
475 IF C$="" GOTO 505
477 IF C$=" " GOTO 505
480 BUF$=LEFT$(BUF$,N-1)
495 N=N-1
500 GOTO 470
505 RETURN
510 REM SCAN RATE CHANGE SUBROUTINE
515 XLAST=PEEK(518)
517 PRINT
520 FOR I=1 TO 10
525 PRINT I;" ";
527 FOR L=1 TO WAIT
528 NEXT L
530 IF PEEK(518)<>XLAST GOTO 550
535 NEXT I
540 PRINT
545 GOTO 517
550 POKE 535,I
555 WAIT=145+(PEEK(535)*200)
560 RETURN
565 END

```

# NO COMPROMISE

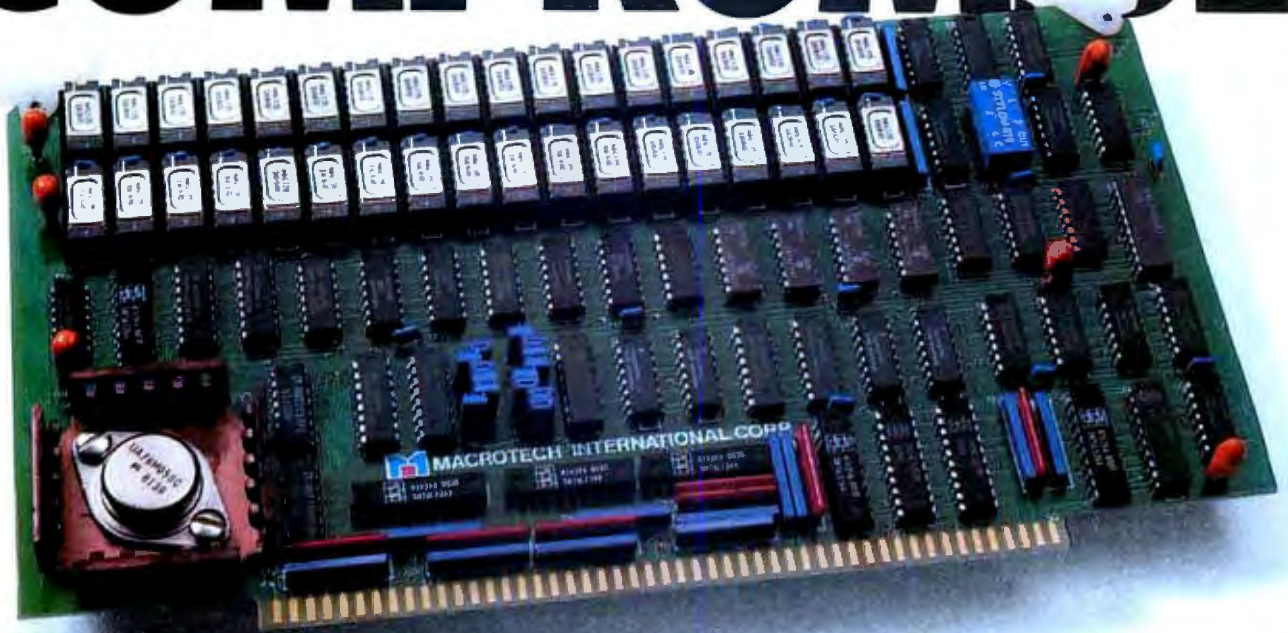

## No Compromise in Performance

- Main-frame type memory mapping for optimal BANK SWITCHED applications or 24-BIT extended addressing
- Operates in *any* S-100 System IEEE/696+ or non IEEE
- DMA operation fully supported†
- 8/16 data transfer protocol†
- Up to 6 MHZ with no wait states; Up to 10 MHZ with automatic wait state assertion
- Parity error detection†
- Double parity in 16-BIT operation

## No Compromise in Features

- All memory/refresh cycle timing is generated ON BOARD providing easy CPU independent characterization
- Ideal for use with the new generation of operating systems: CP/M-80™, CP/M-86™, MP/M-11™, MP/M-86™, OASIS™, UNIX™

## No Compromise in Quality

- Multilayer board and bus signal filtering for noise-free operation
- Thorough 100% final test and burn-in

## No Compromise in Versatility

- Manual provides source listing and complete installation guide for MP/M-II™ BANK SWITCHED multi-user applications
- For the CP/M-2.2™ user: Manual includes implementations of 'Virtual Disk' for solid state disk/file applications

## No Compromise in Customer Support

- Comprehensive technical manual
- User hot-line
- Full one year parts and labor warranty

†In accordance with IEEE-696 standard  
Registered trademarks of \*Digital Research  
\*\*Phase I. and \*\*\*Bell Labs

## ORDER NOW

**(213) 887-5737**

If you wish, send a check or money order for \$1,379 (in California add 6% sales tax where applicable).

Manual available at \$25.00 each refundable with order.

MACROTECH International Corp.,  
22133 Cohasset St., Canoga Park,  
California 91303



MACROTECH International Corp.,  
22133 Cohasset St., Canoga Park,  
California 91303

# Performance, quality, reliability.

**CompuPro** delivers results in the toughest business, industrial, and scientific computing environments. Backed by a one year limited warranty (two years for boards qualified under the **Certified System Component** high-reliability program), **CompuPro** system components are the leading choice of systems integrators world-wide.

When you depend on your computer, choose a computer on which you can depend: IEEE 696/S-100 from **CompuPro**.



**CompuPro** division, Godbout Electronics, Oakland Airport, CA 94614-0355.

## Disk Controllers/Sub-System

**Dual Floppy Disk Sub-System.** Two Qume DT-8s provide over 2,400,000 bytes of storage. With enclosure, Disk 1, power supply, and software: CP/M® 2.2, CP/M-86, SuperCalc-86, dBase II! \$3295.

**Disk 1.** High speed DMA floppy disk controller. \$495, \$595 CSC.

**Disk 2.** High speed DMA hard disk controller for SA4000/F2300 interface. \$795, \$895 CSC.

**Disk 3.** High speed DMA hard disk controller for SA1100/ST506 interface. Avail. Q4.

## CPUs

**CPU 8085/88.** The original dual processor board runs 8 and 16 bit software. \$425, \$525 CSC.

**CPU Z.** High speed Z80 board. \$295, \$395 CSC.

**CPU 86/87.** 16 bit CPU; provision for 8087 math co-processor. \$695, \$850 CSC. 8087: list \$300, factory installed option.

**CPU 16032.** Provision for MMU and math co-processor. Avail. Q4.

## Static 12 MHz Memory

**RAM 20.** Extended addressing or bank select. RAM 20-8K: \$210, \$280 CSC. RAM 20-16K: \$285, \$355 CSC. RAM 20-24K: \$355, \$425 CSC. RAM 20-32K: \$425, \$495 CSC.

## CMOS Static 12 MHz Memory

**RAM 16.** 64K X 8 or 32K X 16 - works automatically with 8 or 16 bit systems. \$850, \$750 CSC.

**RAM 17.** 64K X 8; ultra low power. \$599, \$699 CSC.

**RAM 21.** 128K X 8 or 64K X 16 - works automatically with 8 or 16 bit systems. \$1350, \$1450 CSC.

**RAM 22.** 256K x 8 or 128K X 16 - works automatically with 8 or 16 bit systems. Avail. Q4.

**M-DRIVE.** The first 'solid-state disk drive' can increase operating speeds up to 3500%. 128K M-DRIVE \$1198, 256K M-DRIVE \$2395.

## Interfacers

**Interfacer 1.** Two RS-232C serial ports. \$249, \$324 CSC.

**Interfacer 2.** Three parallel ports plus RS-232C serial port. \$249, \$324 CSC.

**Interfacer 3-5.** Five RS-232C serial ports (2 sync/async, 3 async). \$599, \$699 CSC.

**Interfacer 3-8.** Eight RS-232C serial (2 sync/async, 6 async). \$699, \$849 CSC.

**Interfacer 4.** Three RS-232C serial ports, one parallel port, one Centronics/Epson parallel port. \$395, \$495 CSC.

## High-Performance Motherboards

**6 Slots, \$140, \$190 CSC; 12 Slots, \$175, \$240 CSC; 20 Slots, \$265, \$340 CSC.**

## Other Computer Products

**MPX 1.** Multi-user system front end processor with 16K on-board RAM. \$649, \$749 CSC.

**Enclosure 2.** With shielded/terminated 20 slot motherboard, power supply, fan, dust filter, rugged all-metal construction. Desktop \$825, rack mount \$895.

**System Support 1.** Clock/calendar; RAM/ROM/math processor options; RS-232C serial port; interval timers and interrupt controllers; much more. \$395, \$495 CSC.

## Documentation.

**'CompuPro Product User Manuals: 1975-1980'.** 250 + pages. Softcover, \$20.

**'CompuPro Product User Manuals, Volume 2'.** 300 + pages. Softcover, \$25.

**'Interfacing to S-100/IEEE 696 Microcomputers'.** By Mark Garetz and Sol Libes. Softcover, \$15.

Individual technical manuals also available.

CP/M, CP/M-86, and MP/M are trademarks of Digital Research. SuperCalc is a trademark of Sorcim Corporation.

\*MP/M 8-16 is CompuPro's proprietary edition of MP/M-86 (V2.X), with XIOS by G & G Engineering for CompuPro.

For more information on high-level business, industrial and scientific computing, visit your authorized **CompuPro Systems Center** or circle the reader service number.

# Minspeak

*A semantic compaction system that makes self-expression easier for communicatively disabled individuals.*

---

Bruce Baker  
840 Rolling Rock Rd.  
Pittsburgh, PA 15234

---

Minspeak is a new language prosthesis designed for disabled people who cannot express themselves through speech or hand signs. It is a semantic interface that uses micro-processor technology in a radically new system of communication that reduces the time and effort required for self-expression.

A person using a Minspeak board with fewer than 50 keys can produce thousands of clear, spoken sentences with fewer than 7 strokes. Minspeak users don't even have to know how to spell; they can produce complete sentences without selecting letters, phonemes, or words. The unique Minspeak process permits the user to translate thought into speech.

Minspeak has a modern linguistic

coding system based on general ideas underlying human communication. The coding technique uses sequence to define context, thus exploiting the human mind's ability to process semantic information. Easy-to-understand symbols on each key represent ideas. The meaning of each key image changes according to the sequence in which it is hit. By combining these symbols, whole spoken sentences can be generated. The simplicity or complexity of the symbols will depend on the needs and abilities of the user.

The best way to explain how Minspeak can do all of this is to start with the reasons behind its existence.

## Research and Insights

Several years ago, as research for my dissertation, I set out to study the attitudes of able-bodied people toward people with obvious physical disabilities. To do the research, I needed to speak to disabled as well as able-bodied individuals. The most interesting and insightful group of people I met had cerebral palsy. Ironically, the condition which caused them to have these insights also prevented them from being able to express those insights easily. Communication was slow and inconclusive. Unless you have had some personal experience

with severe physical communication disabilities, you may not fully realize what slow and inconclusive means in this context.

One man I met can communicate only with the aid of an IBM Selectric typewriter. His lack of voluntary muscle control, stemming from a birth injury, precludes not only hand signs and speech but also a reliable eye blink for Morse code. He expresses himself by pushing down on a board with his chin. This signal is in response to the presentation of letters on a revolving metal disk. The disk pauses for two seconds to position each letter in front of a stationary arrow. When he sees the letter he wants, he presses the board with his chin, and the letter is typed. This method is slow and tedious. Creating the word "can" requires two and one half scans of the entire alphabet, and a single sentence often takes 30 minutes to complete.

Another man uses a communication system based on eye motion. A movement of the eyes upward and to the left indicates yes, while a movement downward and to the right means no. In this system, the conversational partner performs the functions of the revolving disk. As I slowly recited the alphabet, he signaled his

---

## About the Author

Bruce Baker did his undergraduate and graduate work in Greek and Latin at Wabash College, Indiana University, and the University of Paris and has taught widely in the United States and Europe. Currently, he is a doctoral candidate in French and Spanish at Middlebury College and Consulting Linguist to the Prentke Romich Co. in Shreve, Ohio. Last year he was named Contributing Editor to Communication Outlook, a publication of the Artificial Language Laboratory of Michigan State University.

---



## A Communications Impasse

The communicatively disabled constitute a group for whom access to microprocessors could mean a real revolution, and a common assumption is that recent technological advances have produced the necessary communication aids. Unfortunately, this is not the case, but the problem does not lie in the new technology.

Neurological damage sufficiently extensive to hamper intelligible vocalization is regularly accompanied by difficulty in control of physical movements. To use any communication aid, the user must be able to actuate some type of switch. Consequently, existing communication systems do not solve the basic human-engineering problem of transferring information from the mind of the communicator to the communication aid, because all systems for complete communication, voiced or unvoiced, have been based upon actuating letters, words, word parts, or phonemes (minimal sound units).

Magnetized or light-sensitive keyboards, new scanning methods, and eye-tracking systems can make the selections easier, but still cannot reduce the number of selections required to communicate whole thoughts.

A nonspeaking person with cerebral palsy faces the task of accessing between 30 and 40 keys to produce a single sentence. A neurologically impaired person able to make one selection every five seconds requires many minutes of intense concentration and labor to produce a single statement.

The normal response time in conversation is less than three seconds. If someone is forced to wait 10 seconds for a reply, anxiety results. If a person is forced to wait five minutes, communication falters; conversation becomes impossible.

If letters are too slow, what about words? Sadly, systems based on actuating words are too extensive and ironically too restrained. The more words there are, the longer it takes to scan through them. Imagine going one by one through 200 words. Even being able to jump through them five at a clip requires an enormous amount of time. And yet 200 words is really a small vocabulary.

If direct selection is physically possible for the user, imagine a board with



**Photo 1:** Hale Zukas has cerebral palsy and uses a communication board and headstick of his own design. A Phi Beta Kappa graduate in mathematics from the University of California at Berkeley, he is one of a group of highly skilled communication-aid users whose cooperation and insights into Minspeak have been indispensable.

400 words. The huge size of such a board, the smallness of the individual squares, and the intellectual complexity of remembering locations of words present obvious difficulties.

Coding can reduce the size of a word board and increase the available vocabulary. A three-number sequence can address up to 999 words, but the human memory requirements are staggering. "What is word 643? Is it 'potato'? No, that's 512." The average person uses thousands of different words every day. And even if the word board could contain most of a user's vocabulary, a simple sentence like "Are you going to the store today?" would require the user to select 7 codes by hitting 21 keys. Research has shown that most people who have tried to use fixed-word boards return to alphabet-spelling boards.

What about a hybrid system that mixes words, letters, and word parts? Photo 1 shows a person using such a system, which he actuates with a headstick. The board has more than 100 squares, each inscribed with a letter, word, or word part. (The word parts are morphemes, un-, -ed, -ly, or frequently used letter combinations, -th, -wh, -tion, -ize.) This approach is an

improvement but, like the others, is still very slow. An average sentence requires in excess of 20 actuations. To get the number of actuations below 20, the board would have to have more than 400 keys. By combining the demand this would make on human memory with the considerable effort required to make a single key selection, it becomes obvious that communication on these systems demands considerable effort from sender and receiver.

A system based on letters is not the answer, and one based on words is worse. A mix of words and letters affords some relief, but not enough. People with communications disorders simply need more "bang to the punch" if they are going to be able to exploit the computer's potential for equalizing physical differences.

The source of the difficulty seems to lie outside the realm of technology. The very nature of the alphabet is at the heart of the problem. The quantity of information borne by a single letter is quite small. Information transfers conducted in such small units will necessarily require many units. Biomedical engineering cannot change this. Perhaps a semantic approach can.

letter choice by making the "yes" eye movement. Although we divided the letters of the alphabet into separate groups of vowels and consonants, and further divided the consonants into those before and after "L" for easier reference, this system is still terribly slow and very limited.

For him to ask the simple question "What did you say?" requires a dozen scans through the alphabet and many questions to establish whether a word is ending or a new word is beginning. The degree of concentration that this system demands of the conversational partner is so great that my friend often lets many misunderstandings pass just to get the central message across. I often wonder if I have understood his message correctly or if my friend feels that the correction isn't worth the time and effort required to make the meaning clearer.

The inability to express oneself is one of the most widespread and catastrophic disabilities. According to a report from the University of

Wisconsin's Trace Research and Development Center for the Severely Communicatively Handicapped, as many as 500,000 people in this country are unable to communicate either vocally or with standard hand signs. The causes are numerous, but among the most common are cerebral palsy, strokes, amyotrophic lateral sclerosis (Lou Gehrig's disease) and vehicular head trauma. One family in four is at some time touched by a serious communication disorder.

Because hundreds of thousands of these people have unimpaired cognitive abilities, the need for easy communication methods becomes all the more important. As the realities of physical communication disorders became apparent to me, I decided to focus my research on finding some means of facilitating nonvocal communication.

### Addressing the Need

Minspeak began as a simple remedy to a single aspect of nonvocal

communication needs, the problem of feedback—called phasis in linguistics. Sentences that check the channel of communication between sender and receiver serve a phatic function.

In face-to-face conversation, speakers need to be assured either through verbal or body language that the message is getting through. Because the listener is aware of this, he nods, makes sounds such as "unhuh,hmm" or says "yes, I see." If the message is complex or the speaker is anxious, the speaker may request additional phatic signs by saying "you know" or mentioning the receiver's name. When a person has a severe physical communication disorder, phatic problems take on a pressing importance for both conversational partners.

Able-bodied speakers have a wide range of vocabulary and syntactical phatic strategies at their disposal. In principle they can generate an infinite number of different phatic sentences, but they do not. Instead, the same phatic utterances are used again and again. A limited number of responses meets the five basic phatic needs most people experience in conversation. They are:

1. To ascertain the quality and quantity of the information being received at the other end of the communication channel. (Am I being heard? Is my meaning comprehended?)
2. To learn whether the information, once understood, is being judged correctly or erroneously. (Am I right, Joe?)
3. To determine how the transmitted information is affecting the emotions of the receiver. (Doesn't he care the article is late?)
4. To estimate how the transaction is affecting the receiver's opinion of the sender. (I won't tell her that; I'll sound so stupid.)
5. To collect information about what's going to happen in the immediate future concerning: (a) the duration of the conversation, (b) possible topic shifts, (c) eventual results of the interaction.

**APPLE®**  
APPLE II PLUS ..... \$999  
*Dist. by Bell & Howell*

**MICROSOFT**  
PREMIUM SYSTEM ..... \$618  
280 SOFTCARD, 16K RAM,  
VIDEOTERM, CPM USERS GUIDE

**VISICORP**  
VISICALC ..... \$189  
VISIDEX ..... \$189  
VISIFILE ..... \$189

**MICROPRO**  
WORDSTAR ..... \$233  
CALCSTAR ..... \$148

**SYSTEMS**

NORTHSTAR ..... \$LOW	400 (16K) ..... \$298	850 Inter ..... \$179
TELEVIDEO ..... \$LOW	800 (16K) ..... \$698	PacMan ..... \$34.95
MICRODECISION .. \$1195	410 Recorder ... \$88	822 Printer ..... \$358
	810 Disk ..... \$448	830 Modem ..... \$158
	CX40 Paddles .. \$17.98	CX853 RAM .... \$88

*Includes: WordStar, CalcStar,  
SpellStar, MBasic-80, Bazic*

KAYCOMP II ..... \$1795

**PRINTERS**  
NEC 7700s ..... \$LOW  
EPSON MX-80 ..... \$478  
*WITH GRAFTRAX*

PRICES SUBJECT TO CHANGE WITHOUT NOTICE  
**TO ORDER CALL:**  
**1-703-750-2631**  
7023 LITTLE RIVER TURNPIKE; ANNANDALE, VA 22003

**THE COMPUTER  
LEARNING TREE**  
*has it. Xedex  
Baby Blue for  
IBM: \$579*

**ATARI**

**1500 PROGRAMS IN STOCK**

STORE HOURS:  
MON.-THURS. 9:30 A.M.-9 P.M.  
FRI. & SAT. 10:00 A.M.-5 P.M.



THE COMPUTER  
LEARNING TREE

# GOOD NEWS

Have you put aside buying a color monitor because it's too expensive? But, have you looked at the new TAXAN RGBvision color monitor? Would you be excited at a suggested retail price of \$399.00 for the RGBvision I, and \$599 for the RGBvision II?



## DO WE HAVE GOOD NEWS FOR YOU!

For those low prices, you can have:

- Full compatibility with Apple III and IBM PC without interface modules
- Compatible with Apple II through the TAXAN "RGB-II" card
- RGBvision I medium resolution - 380(H) lines
- RGBvision II high resolution - 510(H) lines
- Unlimited colors through linear amplifier video circuit and 16 colors for Apple III and IBM PC
- 12-inch, 90° deflection CRT display

Can you really afford to turn all that down without looking at the TAXAN RGBvision monitors? See your local dealer for a demonstration.



TAXAN 12" green phosphor monitor, model KG12N, features an 800 line resolution at center, 2000 character display.



## TAXAN

TSK ELECTRONICS CORPORATION

1524 Highland Avenue  
Duarte, California 91010  
A subsidiary of Kaga Denshi

Apple II and III are trademarks of Apple Computer, Inc.  
IBM PC is a trademark of International Business Machines, Inc.

# Hewlett-Packard on the professional use of personal

## There's a considerable difference between a computer that fits and one that really fits.

There are a lot of places where the basic one-size-fits-all type of personal computer fits in really well. But if you're like most of the technical professionals we know, you'd rather use a tool that was clearly designed for the job you're doing.

That's why we've developed these five very different personal computers just for people like you. And configured each one specifically

just like a real craftsman's tool fits your hand.

Now we'd like to show you, in some detail, just what we mean.

### The HP-41.

You might remember the series 9100 engineering computer we introduced in 1968 for \$5000. Now,

able computing system. Add a printer for hard-copy output. Or our 128k byte cassette for mass storage. Or add both; they'll only take up as much space in your briefcase as three paperbacks.

You can even use your HP-41 as a remote data collector, then link it up with any HP Series 80 personal computer via HP-IL.



ically to operate in technical environments. To interface with instruments and other computers. To give you all the computing power and all the high-level graphics capability you need.

We also offer you a full range of printers, graphic plotters, additional memory systems, input devices, and communications links. Plus over 5000 software programs at last count.

As a result, you can practically design your own system. And have a personal computer that fits your professional environment

for a base price of \$250, you can hold all the power of that system in the palm of your hand.

All by itself, this hand-held computer can help a petroleum engineer evaluate gas or oil reservoirs. Or help civil engineers do critical computations in the field.

Add the new Hewlett-Packard Interface Loop (HP-IL), and you can turn your HP-41 into a powerful, port-

### The HP-85.

Complete with an integrated tape drive, printer and CRT, this typewriter-size system fits easily in a crowded work area. Where you can use its impressive number-crunching power any number of ways. For waveform analysis. Regression analysis. Linear programming.

Add the HP-IB interface, and you can control up to 14 instruments simultaneously. Add our Data Communications Pac and you can tie into another

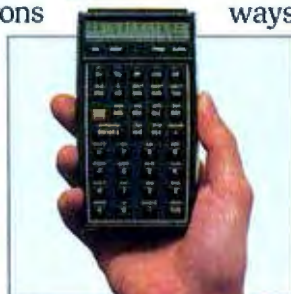

All the power of our 9100 Series Desk-top Engineering Computer. Now you can hold it in the palm of your hand.

# computers.

## ence between the one-size-fits-all

on-site computer, a major data network, or a national timesharing service.

You can even use this portable machine to do all these same jobs out in the field. And more.

### The HP-87.

The HP-87 sets a new level of performance for personal computers in its price range. You get built-in screen graphics, up to 544k bytes of RAM, and an 80-column integrated CRT. Plus the same flexible I/O structure for control applications as the HP-85. Because of its extended memory, you can take advantage of a VisiCalc<sup>®</sup> PLUS worksheet with up to 16,000 cells. And since the HP-87 has a built-in HP-IB, it's easy to add instruments, disc drives, printers, plotters, and even a graphics tablet. To give you even more to work with, there's an optional CP/M<sup>®</sup> module. And all applications developed for the HP-85 in BASIC are upward-compatible to the HP-87.

### The HP 9826.

Designed to handle high-speed data acquisition and tests, the 9826 has a powerful MC 68000 CPU, a built-in flexible disc, up to 2 megabytes of read/write memory, and power-fail protection. Plus a built-in HP-IB in-

terface and a variety of other interface cards, so you're free to concentrate on testing. Instead of system configuration.

To give you even more flexibility, you can run applications in HP-enhanced BASIC, HPL, or Pascal. We've also built a CRT display with advanced graphics into the system, so you can see and interpret your data the instant you get it. And since everything about this system is built for speed, we've developed a special rotary control knob that lets you edit programs, calibrate instruments, and control motor speed, all with fast analog inputs.

### The HP 9836.

This full-function workstation does it all: design, computation, and high-speed testing. Because it gives you all the high-performance features of the 9826. And then some. With the 9836, you get a big, easy-to-read CRT. Sophisticated graphics capability. Two flexible disc drives. Room for up to two megabytes of memory. And an even longer list of engineering software and peripherals to choose from.

Our 7470 Plotter. One of many peripherals that help make our personal computers really personal.



are just the five personal computers we've developed for technical professionals; we also make a full range of person-

al computers for business professionals.

So. Before you decide to adapt your routines to fit the needs of a one-size-fits-all computer, we think you should get in touch with us first. And see what it's like to have a personal computer that really is personal.

Just return this coupon, and we'll send you full information on any or all the personal computers we make.

Hewlett-Packard  
1820 Embarcadero Road, Palo Alto, CA 94303  
I'd like to see which of your personal computers fits the way I work best. Please send more information on these models:

HP-41  HP-85  HP-87  HP 9826  
 HP 9836

Name \_\_\_\_\_

Title \_\_\_\_\_

Company \_\_\_\_\_

Address \_\_\_\_\_

City/State/Zip \_\_\_\_\_

77136



**HEWLETT  
PACKARD**

RS 232

HP-IB

HP-IL

VisiCalc<sup>®</sup> is a registered trademark of VisiCorp.  
CP/M<sup>®</sup> is a registered trademark of Digital Research, Inc.

A wide variety of interfaces for technical environments, including HP-IB, HP-IL, RS 232, GPIU, and BCD.

TCG-203

Please Circle The Product/Products for Which You Would be Interested in Receiving Information:

HP-41—CIRCLE 216 HP-85—CIRCLE 218 HP-87—CIRCLE 220  
HP-9826—CIRCLE 217 HP-9836—CIRCLE 219

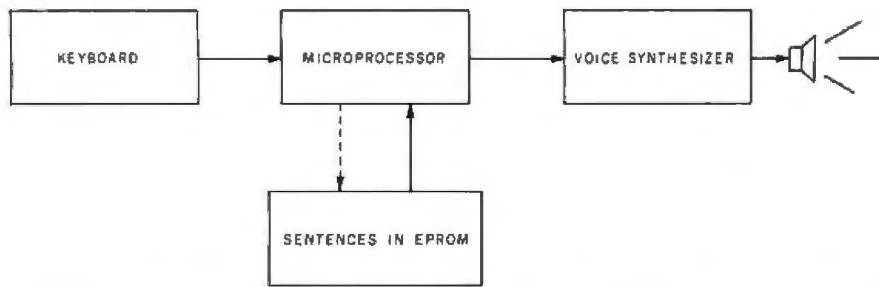

Figure 1: The bulk of the Minspeak's memory is erasable programmable read-only memory (EPROM). The voice synthesizer used in the first prototype was the Votrax SC-01.

I prepared 26 sentences to satisfy these phatic needs. The simplicity of implementation can be illustrated with the rotating-disk communication system. English sentences do not begin with question marks, so I decided to use them to designate the beginning of a phatic comment. Each of the 26 sentences is written on the user's lap tray and marked with a single letter. He can communicate an entire sentence by hitting the ? key and a letter. The receiver then consults the lap tray to see which sentence corresponds to the letter. For example, when the user selects ?G, the receiver can look at the lap tray and read "I'm pleased by what is being said."

These sentences facilitated conversations on a number of different silent systems and had the potential of being even more effective if they could be generated on voice-synthesis equipment. If phatic sentences could be designed context free and reusable, so could other sentences. The success of the phatic experience could be applied to the rest of the communication process.

If users of communication aids had at their disposal a collection of several hundred multipurpose sentences, all sorts of routine but important transactions could be made easier for them and for their associates. If users could access these sentences through short codes, communication could be conducted almost at the speed enjoyed by able-bodied speakers.

### Taking It One More Step

The redundant character of daily speech as seen in the phatic project

became a primary concept of a new system for communication. I called it Minspeak, a parody on the "newspeak" in George Orwell's *1984*, with the Min for minimum. My first task involved constructing thousands of sentences that were reusable and appropriate for most daily situations.

I designed short codes to access these sentences through a radical alteration in the representational information of an alphanumeric key-

---

## Users can easily remember a large number of sentence sequences.

---

board. Instead of letters, the keys bear images taken from daily life. These images stand for concepts rather than words. Some symbolize linguistic functions, some the activities of daily life; others denote styles of speech and mood.

Most important, each key has a range of significance, including a function, several activities, a style, and a mood. The sense of each key is defined by the order in which it is struck. This multiplicity of meaning is called polysemy and is the way human language works.

For example, in the sentence "They will play a tape of the play," no one would confuse the two uses of the word "play." Many of our words in English are polysemous and depend on their context for meaning.

Polysemy and redundancy are the

foundation of Minspeak. The incorporation of polysemy into the design allows a small number of keys to have hundreds of referents. The amount of information carried by a letter is small; that borne by a word is considerably larger. The information in a visual image is enormous.

### Hardware Configuration

Minspeak requires a keyboard coupled with a microprocessor. The EPROMs are used to store complete sentences without regard to individual words, phonemes, or letters. In addition, a commercially available speech synthesizer such as the Votrax Speech PAC with an SC-01 voice-synthesizer chip can be used. The output of the voice synthesizer is in turn coupled to a loudspeaker which generates audible synthetic speech. Because the preprogramming is done on the basis of semantic rules, Minspeak will be able to achieve a vocal quality unobtainable with text-to-speech methods. (See figure 1 for a diagram of that configuration.)

The keyboard design is illustrated in figure 2, with each circle representing an individual key. Each key has an illustration of a common object or an action. In most Minspeak embodiments the majority of the keys also have identifying sequential numbers, a letter that corresponds to the number, a portion of the human anatomy, and a proper name. The keyboard design shown in figure 2 was intended to be used by someone with a relatively high level of intellectual achievement. (See table 1 for a detailed description of the keys.) Simpler keyboards are designed for users with different intellectual levels.

For example, with this keyboard design, key #10 has an illustration of philosopher Bertrand Russell, famous for his paradox, "the set of all sets, not sets of themselves, etc." This key is used to change topics. A simpler board would use the same key for this purpose but would illustrate it with a frog that is jumping. (See figure 3 for examples of other keyboard images.)

The microprocessor is programmed so that hitting any one key twice designates that key's central image as the

## THE **PromptDoc**<sup>®</sup> MANUAL MAKER

You know better user manuals sell more software, but how do you make better user manuals? How do you identify just the right details to motivate prospective

users to buy? How do you organize these details into a sequence that makes sense to first-time users while it provides ongoing reference to veterans? How do you format and package a manual so it's attractive enough to get attention yet clear enough to be readily understood?

And, how do you do all this at a pace that keep up with your product release schedule? The Prompt Doc<sup>®</sup> Manual Maker is the answer.

### Introducing Computer-assisted Writing

Imagine a software product that prompts you through the process of planning, outlining and writing a user manual and even supplies boilerplate introductory and transitional text. Envision reducing your user manual preparation process to this:

1. Identify manual, select boilerplate chapter files from menu
2. Edit chapter table of contents to tailor sequence and terminology to your product needs
3. Pause while computer modifies boilerplate chapters to match edited table of contents and builds a skeletal manual in preformatted CP/M<sup>®</sup> text files
4. Use your word processor to edit the skeletal manual into a working draft, supplying product details as prompted
5. Tell computer to purge prompts and instructions from working draft, and build new Table of Contents; publish review draft
6. Review the draft for accuracy and usability; revise, polish and publish as instructed by documentation

Compared to your current process that may sound more like a software maker's dream than a real product. It's a dream all right—a dream come true called the Prompt Doc<sup>®</sup> Manual Maker. It's the only product of its kind.

### Consider These Benefits

Improved productivity—with Prompt Doc<sup>®</sup> you can gain as much as 40% on typical manual writing jobs.

Project control—with prestructured modular chapters, writing tasks can be segmented without losing continuity.

Manual uniformity—by product, by product line, by company.

Quality assurance—the boilerplate files help assure completeness and usability; the Prompt Doc<sup>®</sup> Writer's Guide gives publishing instructions.

Proven performance—based on the Prompt Doc<sup>®</sup> methodology, the structures and outlines have been proved in myriad applications for the past four years; now we've tailored it specifically for the commercial software vendor.

### Reasonable Price

\$245 for software and two manuals, \$45 for manuals only. This product will begin paying for itself the minute you start using it and continue making you money each time you publish a manual. What could be more reasonable?

### CP/M<sup>®</sup> Compatible; Uses Your Word Processor

Now available for use with WordStar<sup>®</sup> and other word processors on the Apple<sup>®</sup> II with the Softcard<sup>®</sup> and on standard CP/M<sup>®</sup> systems.

### Use The Coupon Now

You know a better way to make better manuals can enhance your competitive position. Why wait another minute? Complete the coupon now and mail it to Prompt Doc<sup>®</sup>, 833 West Colorado Avenue, Colorado Springs, CO 80905. Or, if you'd rather not wait for the mail, call (303) 471-9875.



## **PromptDoc**<sup>®</sup>

See our seminar ad in this issue.

Prompt Doc is a registered trademark of Prompt Doc, Inc. Apple and Apple II are registered trademarks of Apple Computer Inc. Softcard is a registered trademark of Microsoft Corporation. CP/M is a registered trademark of Digital Research, Inc. WordStar is a registered trademark of MicroPro International Corporation.

I need the Prompt Doc Manual Maker now! Send a copy to:

Name \_\_\_\_\_ Telephone (\_\_\_\_) \_\_\_\_\_  
Address \_\_\_\_\_

Configuration:  Apple II  CP/M  8" CP/M  
 Other \_\_\_\_\_

Send manual only.  
 My check is enclosed for \$\_\_\_\_\_.  UPS C.O.D.  
 You may charge my \_\_\_\_\_ VISA \_\_\_\_\_ MasterCard  
Account # \_\_\_\_\_  
Amount \$ \_\_\_\_\_ Expiration Date \_\_\_\_\_  
Signature \_\_\_\_\_

I need more information. Send it to the address above.  
Dealer inquiries invited.

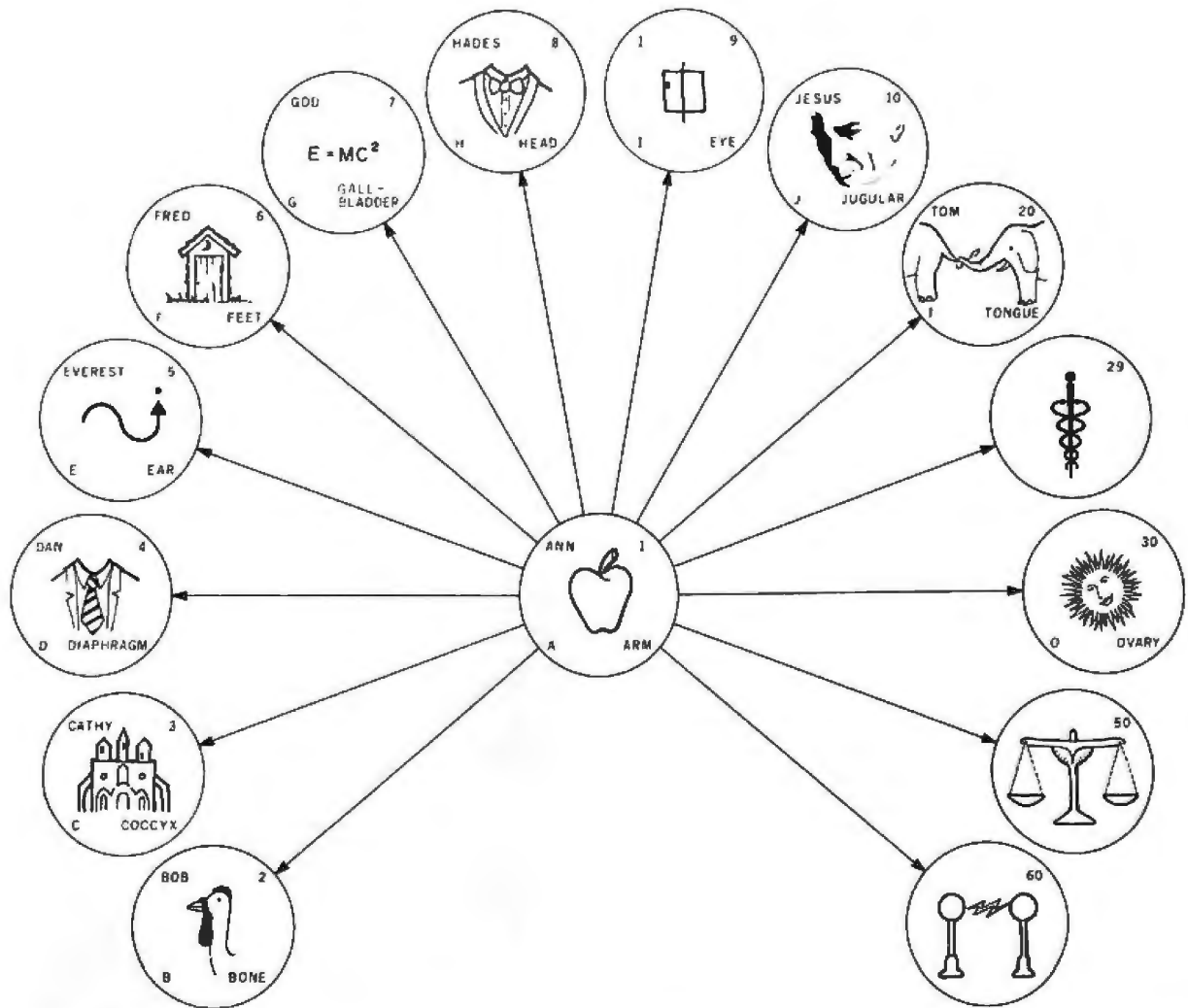

**Figure 2:** The images on Minspeak keys represent neither letters nor words, but concepts. Because a picture is, indeed, worth a thousand words, the meanings of the symbols can change according to the order in which the keys are struck. Each image is rich in associations. In short and obvious combinations, they represent whole thoughts. When such combinations are actuated, sentences are spoken by the synthesizer. (See table 1 for a description of the information on the keys. See table 2 for examples of specific sequences.)

Key #	Image	Theme	Letter	Anatomy	Person
1	apple	eating or food	A	arm	Ann
2	turkey	bad or danger	B	bone	Bob
3	cathedral	wheelchair	C	coccyx	Cathy
4	tie, shirt	dressing or clothing	D	diaphragm	Dan
5	directional arrow	transport or travel	E	ear	Everest
6	privy	ablutions, bathing, or water	F	feel	Fred
7	equation	philosophy or ideas	G	gall bladder	God
8	luxedo	formalities, departures, or greetings	H	head	Hades
9	Chinese symbol, center	personal opinions or disclosures	I	eye	I
10	Bertrand Russell	logic or modality	J	jugular	Jesus
20	elephants	tag questions	T	tongue	Tom
29	caduceus	medical	—	—	—
30	sun	positive expression or happiness	O	ovary	—
50	scales	typing mode	—	—	—
60	electric current	electricity or control	—	—	—

**Table 1:** Each key may have several functions depicted. The majority of the keys have a number, a letter, a portion of human anatomy, a name, and an illustration. The theme of the key is the topic that is selected when the key is hit twice. The information in this table corresponds to the keys pictured in figure 2.



# NO COMPROMISE ON P3\*

## I/O TECHNOLOGY S-100/IEEE-696 PLUG-INS

### DUAL GPIB-488 INTERFACE BOARD

The Dual GPIB-488, is a Stand-Alone, independently controlled Dual Channel IEEE-488, 1978 Interface Controller. Interface Activity Modes such as Controller In-charge, Controller Assigned or Terminal Bus Slave and all Interface Functions, their Sub-Functions including Extended Functions, are handled by an On-Board 5MHz Processor and DMA Controller. 500K Byte Data rates are easily achieved with minimum host processor overhead.

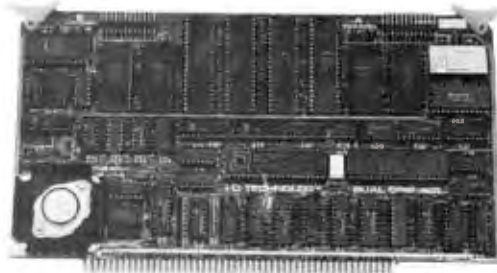

Assembled and tested, P/N 52748-800-100 \$475.00

### 12-BIT A-D-A CONVERTER BOARD

**8 Channel A-D:** 12 microsec. Conv. time, Programmable Gain & Offset Voltage control, Diff./Single Voltage or Current Input.  
**8 Channel D-A:** 2 microsec. Settling time, Bipolar V / Unipolar I Output, Programmable Reference levels, DUAL-PORTED Refresh RAM. 16 or 8-bit Data Transfers via Program I/O or Memory Mapped I/O. Extended Addressing and much more.

Assembled and tested, P/N 52748-900-100 \$375.00

### SOLID STATE DISK/BULK MEMORY SYSTEM

Up to 10M Byte capacity w/battery back-up. May be shared among 16 different users / S-100 Systems. Complete with software for most S-100 Operating Systems.

P/N 52748-010

### 128K x 8 / 64K x 16 CMOS STATIC RAM MODULE

TOP BOARD SUPPORT  
LOGIC AND  
32K x 8 / 16 x 16 RAM



BOTTOM BOARD  
96K x 8 / 48K x 16 RAM

150 nsec. Access, 2716 compatible RAM devices, Extended Addressing, Programmable wait cycles, Write protect and Bank select. Battery back-up capability. No wait cycles with fast 16-Bit Processors. The module's "Piggy-back" arrangement provides high density @ low input power yielding an improved MTBF and space utilization.

Assembled and tested, P/N 52748-650-128 \$825.00

### MULTI-FUNCTION I/O BOARD

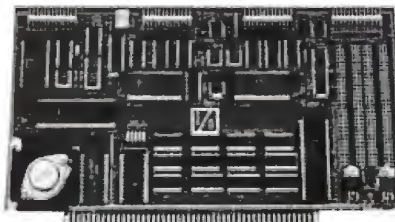

Assembled and tested.  
P/N 52748-100-101 \$325.00

Two Serial SYNC/ASYNCRS-232, TTL or Current Loop with XTAL controlled Dual Baud Rate Generator, Four Parallel Ports (Input, Output or Bi.). Three 16-Bit timers, 8-level Interrupt Controller and large Proto area with +5V, ±12V for custom applications.

### PROTOTYPING BOARD KIT

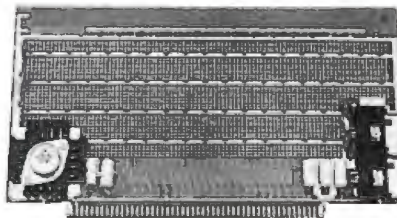

Can be used for wire-wrap or solder prototyping projects. Comes complete with +5, ±12V Regulators, Heat sinks, 2 Bus Bars, Filter Capacitors and Manual.

Kit P/N 52748-400 \$49.95

**\* PERFORMANCE, low POWER, PRICE**



Calif. residents add 6 1/2 % sales tax.  
U.S. Domestic Price, F.O.B. Factory.  
© I/O Technology, 1982

POST OFFICE BOX 2119  
CANYON COUNTRY, CA 91351  
(805) 252-7666

Circle 227 on Inquiry card.



**CANYON COUNTRY  
CALIFORNIA**

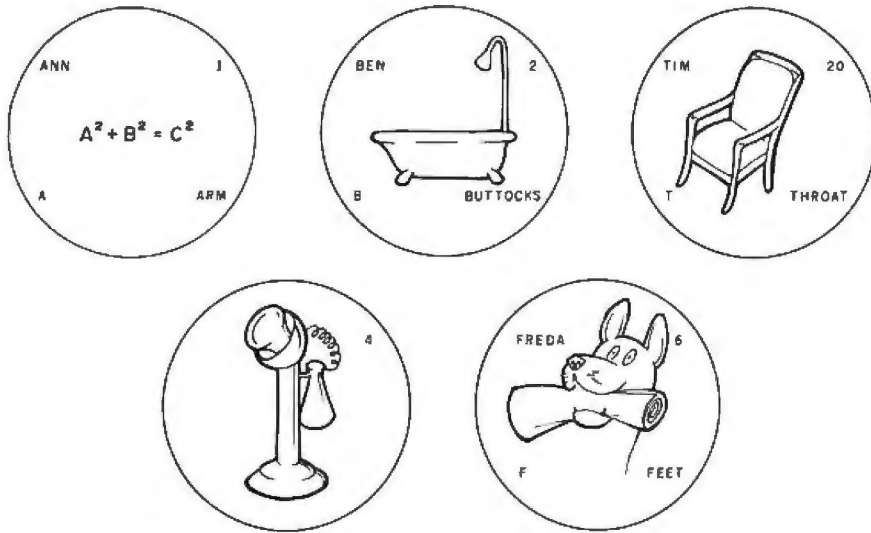

**Figure 3:** Minspeak keyboards designed for people who can read have numbers and letters to aid in sequencing and lessen any unnecessary memorization. The letter generally stands for a word associated with the central concept behind the key. Key #1 prefaces statements dealing with numbers. The associated word is algebra. This key was designed for a 40-year-old man with cerebral palsy who is beginning college. Key #2 deals with cleaning and liquids. It's associated word is bath. Key #20 deals with transport and is from a keyboard for a person who does not like the traditional wheelchair symbol. The associated word is throne. Key #4 is from a keyboard designed for a Minspeak user who does not read. The associated idea is "call 4 help." Key #6 is for commands. The associated word is fetch. The names in the upper left area of the keys are of family members and friends.

topic (see figure 4). All keys hit thereafter designate ideas associated with that topic. This continues until the user signifies a change of topic by hitting key #10.

For example, when the user hits key #1 twice, the topic of eating is established. When key #2 is hit, the sentence "Get that food out of my mouth!" is read from memory and spoken through the voice synthesizer and loudspeaker. If key #3 had been hit after the eating topic had been established, the sentence "The position of my chair is not right for eating" would have been generated. Using key #4 would have produced "Look out; the food is getting on my clothes."

The programming also recognizes a single keystroke after the establishment of a topic as a request for a negative sentence or expression. This was done because negative sentences are often of an emergency nature and the user needs to be able to convey the message quickly and easily. A positive phrasing of each of the preceding

# General Software

**Mailing Address:**  
1454 S. 25th St.  
Terre Haute, IN 47803  
WE HONOR  
VISA and MASTERCHARGE

**TOLL FREE - Outside Indiana**  
1-800-457-0517  
**ORDER DESKS**  
(812) 234-9421

Best Selection Best Service

Write for our famous CATALOG. Contains many items not in ad. Still only \$1.00 (refund with purchase) Outside US add \$10 plus Air Parcel Postage. Add \$3.50 postage and handling per each item. Indiana residents add 4% sales tax. Allow 2 weeks on checks. COD add \$3.00 per item. Prices subject to change without notice. All items subject to availability.

	Disk with Manual	Manual Only
<b>ARTIFICIAL INTELLIGENCE</b>		
Dental (PAS-3)		\$849/40
Medical (PAS-3)		\$849/40
<b>BYROM SOFTWARE</b>		
*BSTAM		\$149
*BSTMS		\$149
<b>DIGITAL RESEARCH</b>		
CP/M		
2.2 Intel MDS-800		\$149/25
Northstar (Horizon)		\$149/25

Micropols	\$169/25
TRS Model II	\$159/35
CB-80	\$459/35
CBasic2	\$ 98/20
Pascal MT +	\$429/30
Compiler	\$316/20
SPP	\$140/15
<b>FRIENDS</b>	
ACCESS 80 I	\$249/50
ACCESS 80 II	\$429/50
<b>FRONTIER SOFTWARE</b>	
Professional	
Time Accounting	\$549/40
General Subroutine	\$269/40
Application Utilities	\$439/40
<b>ISA</b>	
Spellguard	\$229/25
SP/Law	\$109
<b>PASCAL LANGUAGE</b>	
Pascal Z	\$349/30
Pascal MT + V5.5	\$429/30
Compiler	\$316/20
SPP Only	\$140/15
<b>KEY BITS</b>	
Wordsearch	\$179/50
String 80	\$ 84/20
String 80 (Source)	\$279
String Bit	\$ 65
<b>MICRO AP</b>	
Selector IV	\$269/35
Selector V	\$469/50
SBasic	\$269/25
<b>MICRO TAX</b>	
*Level I	\$249
*Level II	\$995
*Level III	\$749
*Combo II + III	\$1495
Microsoft 5 3	49
Run time module	
<b>MICRO PRO*</b>	
Wordstar	\$309/60
WS Training Guide	20
WS Custom Notes	\$429/na
MailMerge	\$109/25
WS-Mailmerge	\$419/85
Dataser	\$249/60
DS Custom Notes	\$429/na
Calcstr	\$259/na
Superson I	\$199/40
Spellstar	\$175/40
<b>MICROSOFT</b>	
Basic-80	\$298
Basic Compiler	\$329

Fortran-80	\$.349
Cobol-80	\$.629
M-Sort	\$.124
Macro-80	\$.144
Edit-80	\$. 84
MuSimp/muMath	\$.224
MuLsp-80	\$.174
<b>ORGANIC SOFTWARE</b>	
*Textwriter III	\$.111/25
*Datebook	\$.269/25
*Milestone	\$.269/30
<b>PACIFIC SOFTWARE</b>	
Sequitur	
Onyx, Plexus	\$.3495/NA
PDP.11	\$.5000/NA
<b>PEACHTREE* SOFTWARE</b>	
General Ledger	\$.399/40
Accounts Receivable	\$.399/40
Accounts Payable	\$.399/40
Payroll	\$.399/40
Inventory	\$.399/40
Mailing Address for P5 Version	\$.399/40
Series 6-Peachtree	add \$119
CPA	\$.799/40
Property Mgt	\$.799/40
Passive Payroll	\$.449/40
Series 7-Peachtree	
Sales Tracker	\$.3049/55
AR Sales Analysis	\$.1299/50
Inventory	\$.799/40
Order Entry	\$.669/40
<b>SOHO GROUP</b>	
Matchmaker	\$. 97/20
Worksheet	\$.177/20
<b>SORCUM</b>	
*Pascal/M Z80	\$.349/40
Pascal/M 86/88	\$.449/40
*Act 65	\$.149/20
*Act 68	
*Act 69	
*Act 86/88	\$.149/25
*Trans 86	\$.119/25
*Supercalc	\$.269
<b>SOUTHERN COMPUTERS</b>	
*Rad	\$.224/35
*Rad FP	\$.349/35
*RFP	\$.224/15
*Recover	\$. 75
*RADAR	\$.449/25
ISS	\$.224/20

<b>STRUCTURED SYSTEMS GROUP</b>	
GL, AR, AP, PR, OE	\$.849/40
Call for others	
<b>SUPERSOFT</b>	
*Diagnostic II	\$. 84/20
*Forth	\$.149/30
*SSS Fortran	\$.219/30
*Fortran w/RATFOR	\$.289/35
*C Compiler	\$.175/20
*Disk Doctor	\$. 84/20
*Term I	\$.129/25
*Term II	\$.169/25
Z8000 Xassembler	\$.449/35
Others less 10%	
<b>WHITESMITHS</b>	
C Compiler	\$.700/40
Pascal (incl C)	\$.900/45
Cross Compiler 8080/Z80 host	
Target M68000, PDP11, 11/70, VAX	\$.1400/50
<b>IBM PERSONAL COMPUTER</b>	
Wordstar 3.0	\$.309/60
Mailmerge	\$.109/25
Supercalc	\$.269/NA
Visicalc (256K)	\$.229/NA
Optimizer	\$.200/NA
<b>CP/M-86</b>	
Supersoft C	\$.500/NA
Pascal MT + 86 w/SPP	\$.730/NA
CBasic-86	\$.299/NA
SuperCalc	\$.369/NA
SuperSoft C Compiler	\$.450/NA
Wordmaster	\$.Call
<b>MISCELLANEOUS</b>	
*dBASE II	\$.575/50
Plan-80	\$.269/30
*Fabs (B-Tree)	\$.159/25
Ultrasoft	\$.159/25
*Super vxx	\$. 89/15
*Micro B+	
(Specify Language)	\$.229/20
*Mini Model	\$.449/50
*Spellbinder	\$.349/45
*Statpak	\$.439/40
*"The Word"	\$. 75
*Lynx	\$.199/20
Mig. Inventory and Control Program	
T1990, 300 Meg. storage required	
Distributed in Cobol object code	
Call for info	\$.20000/NA
Write for catalog (\$1.00) and other listings	

\* Available for Apple with Softcard

A

# INFOWORLD RAVES ABOUT PERFECT WRITER!™

**Read for yourself what InfoWorld said about this incredible word processor!**

“Perfect Writer would be my choice for a word processor in my home.”

“Perfect Writer lives up to its name. This product appears to be a very solid piece of software. Text handling is convenient and versatile and you are given an unusually complete set of commands.”



All quotes are from InfoWorld's Perfect Writer software review, by John Ford, June 14, 1982.

“'User friendly' is a trite, but true description of Perfect Writer.”

“Personally, I found the full-screen text to be comfortable and in most respects superior.”

“The documentation is superb...”

“I believe Perfect Writer will serve individual writers very well indeed.”

“I can recommend the program as a model of clarity.”

## AND WE'VE GOT IT FOR JUST \$249.

No wonder our phones are ringing off the hook! After InfoWorld went wild about Perfect Writer, it's become the hottest piece of software we handle.

Why? Because Perfect Writer is simply the best word processor you can buy at any price and 800-SOFTWARE is selling it for just \$249. That's \$140

off the manufacturer's suggested retail price of \$389!

What's more, we are the Perfect Writer experts—the first dealer to stock Perfect Writer in the entire United States!

What does this mean to you? Product knowledge and support exper-

tise you simply won't find any place else. Plus the giant inventory, fast delivery and commitment to first class service you've come to expect from 800-SOFTWARE.

But let us prove how good we are. Just pick up the phone and call us toll-free. We're waiting for your call.

TO ORDER CALL TOLL-FREE:  
**800-227-4587**  
In California, call: 800-622-0678  
CA residents add sales tax.

Or write:  
800-SOFTWARE, INC.  
185 Berry Street, Suite 6820  
San Francisco, CA 94107  
 Purchase orders accepted.  
 Prompt UPS 3 day Blue Label service.  
 Call for shipping charges.

 **800-SOFTWARE**



CHECK THESE OTHER  
GREAT PRICES:  
**Wordstar™ \$249**  
**dBase II™ \$495**  
**SuperCalc™ \$199**

Copyright 1982 by CW Communica-  
tions, Inc., Reprinted from InfoWorld.

PW10

Circle 2 on inquiry card.

## The Influence of Language

Language has such a pervasive influence on perceptions and thought processes that so far we've been unable to devise a way to measure the depth or extent of that influence. To say an issue is "just semantic" is a contradiction. A person may as well say "just life or death." Americans of African descent are not nit-picking when they insist that "black" replace "colored." Nor are women being petty when they use "Ms." The way a person is described affects how he or she is treated.

People with physical disabilities can be isolated by the language used to describe them. I recently formed a small company and one of my two partners uses a communication aid because he has cerebral palsy. For me to call him or even think of him as "afflicted" would be bad for business. To call someone a "victim" of polio or to say a person is "suffering from multiple sclerosis" leaves a negative impression. Most people find it hard to deal with anyone they view as a "suffering victim." To say "He had polio" is easier and clearer.

"Confined to a wheelchair" is an especially unfortunate phrase. People are not "confined" by wheelchairs; they use them for mobility. Some people are tortured for years by unsuccessful attempts to enable them to walk. Wheelchairs can operate with grace and efficiency. It's harmful to perpetuate prejudices against them.

Adults with disabilities are often spoken of and hence thought of as children. I know a gray-haired professional with cerebral palsy whose wife was recently asked who the crippled boy with her was.

On the other hand, try not to let this list of "don'ts" make you feel anxious, because people with disabilities are often isolated by other people's fear of making a faux pas. Be natural. Most people with disabilities are skillful in dealing with all kinds of situations. It's the prejudices of the able-bodied community that are destructive.

When I am in a quandary about whether to use a certain word or not, I just ask myself, "Would I like my partner described that way?"

More information is available in a pamphlet, "4 Letter Words in the Dictionary of the Disabled," from United Cerebral Palsy, 66 East 34th St., New York, NY 10016.

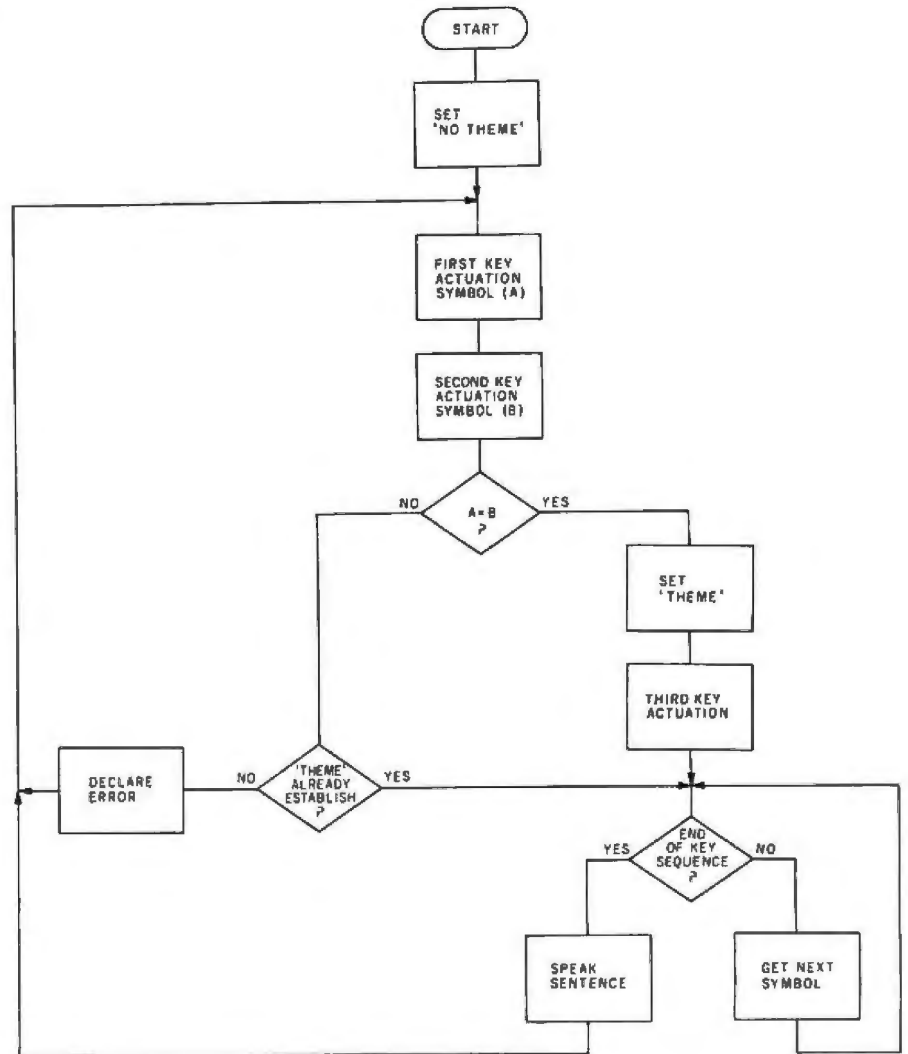

Figure 4: The Minspeak algorithm. To select a topic strike the corresponding key twice. All sequences then deal with that topic until another topic is selected. Escapes, though not shown, are available for a variety of emergency situations.

examples can be made by modifying the key sequence. The following sequence—key #1 twice (to set the topic), key #30 once (to denote a positive response), and then key #2 or key #4—would result in "It's okay; I'm not choking" or "It's all right if a little food gets on my clothes."

For a severely disabled person to say these sentences on a text-to-speech or phonemic system would require the user to select dozens of keys plus have the ability to read and spell very well. Minspeak requires no more than four key selections, and reading and spelling don't matter.

Many other variations and combinations of the keys are available to the user and will result in different

sentences being output. For examples of other sequences, see table 2. For users with some linguistic sophistication, a series of keys can provide a method for altering existing sentences through insertions and deletions.

Other options include changing the person, number, tense, voice, and mood of verbs. Subjects and objects can be modified, eliminated, or reversed. A "fudge-factor" key introduces sequences to produce more than 100 sentences linguistically designed to correct or clarify enunciated sentences that inaccurately represent the user's thoughts. An example of one of these sentences could be "That's not what I meant." Style and context keys can easily alter the

# HARD DISK PACKAGE DEAL.



## THE PACKAGE.

XCOMP is now offering a **10MB** 5¼-inch subsystem that OEMs will consider a blessing.

Now, a **Hard Disk Special** that offers **more**.

**More Storage. More Value. More Support** and more **Speed**. The speed alone is unmatched in the industry. XCOMP Controllers are 3 times faster than some of the basic "cheapie" controllers.

With the XCOMP "Package Deal" you get the **10MB** (formatted) **Drive and the Controller**. There are two models to choose from: 1) The ST/S for S100 computers and 2) Our ST/R General Purpose Controller with simple 8-bit micro interface for single board computers. Incidentally, there is an optional Z-80 Adapter for the general purpose computer that allows you to just 'plug 'er in'. You don't have to build a thing.

### SUPER FAST CONTROLLER.

The XCOMP Controller is a major key in this Hard Disk Subsystem. Speed-up features include interleave without table look-up, block-deblock with controller buffer and custom bipolar micro-programmed processor.

### MORE SOFTWARE. SAVE VALUABLE TIME.

Available for this subsystem is software for testing, formatting, I/O drivers for CP/M®, **plus** an automatic CP/M® driver attach program!

A sophisticated formatting program assigns alternate sectors for any weak sectors detected during formatting. This assures the lowest possible error rate . . . at least **ten times lower** than floppies!

### WARRANTY.

XCOMP's super Hard Disk **10MB** Subsystem has a complete one-year warranty on parts and workmanship!

### A LITTLE MORE.

Just go ahead and compare the price and features we are offering with the price and features of any other 5¼-inch . . . or even 8-inch system.

## THE DEAL.

The entire **XCOMP 10MB Hard Disk Subsystem** sells for only **\$1,280.**, Qty 1.

Software is \$350., one-time charge (req. with first system).

Simply ask for additional details by sending in the coupon or by calling XCOMP.



7566 Trade Street, San Diego, CA 92121  
(714) 271-8730/TLX 182786

## XCOMP

**YES!** I'm interested in your "Package Deal". Please send me more information on the following:  S100 Hard Disk Subsystem  General Purpose Subsystem.  SG/R Controller for SA1000 interface.  SM/R General Purpose Controller for Storage Module Drives.  AN/R Controller for ANSI interface disk and tapes.  SG/S, SM/S and AN/S same as others for the S100 bus.

Name \_\_\_\_\_

Company Name \_\_\_\_\_

Title \_\_\_\_\_ Phone \_\_\_\_\_

Address \_\_\_\_\_

City \_\_\_\_\_

State \_\_\_\_\_ Zip \_\_\_\_\_

CPIH is a registered trademark of Digital Research.

## MAKING LIFE EASIER FOR OEMs

# ZX81



## Introducing the Sinclair ZX81.

If you're ever going to buy a personal computer, now is the time to do it.

The Sinclair ZX81 is the most powerful, yet easy-to-use computer ever offered for anywhere near the price: only \$99.95\* completely assembled.

Don't let the price fool you. The ZX81 has just about everything you could ask for in a personal computer.

### A breakthrough in personal computers.

The ZX81 is a major advance over the original Sinclair ZX80—the first personal computer to break the price barrier at \$200.

In fact, the ZX81's 8K extended BASIC offers features found only on computers costing two or three times as much.

Just look at what you get:

- Continuous display, including moving graphics

# THE \$99.95 PERSONAL COMPUTER.

- Multi-dimensional string and numerical arrays
- Mathematical and scientific functions accurate to 8 decimal places
- Unique one-touch entry of key words like PRINT, RUN and LIST
- Automatic syntax error detection and easy editing
- Randomize function

useful for both games and serious applications

- 1K of memory expandable to 16K
- A comprehensive programming guide and operating manual

The ZX81 is also very convenient to use. It hooks up to any television set to produce a clear 32-column by 24-line display. It comes with a comprehensive programming guide and operating manual designed for both beginners and experienced computer users. And you can use a regular cassette recorder to store and recall programs by name.

### Order at no risk.\*\*

We'll give you 10 days to try out the ZX81. If you're not completely satisfied, just return it to Sinclair Research and we'll give you a full refund.

And if you have a problem with your ZX81, send it to Sinclair Research within 90 days and we'll repair or replace it at no charge.

### Introducing the ZX81 kit.

If you really want to save money, and you enjoy building electronic kits, you can order the ZX81 in kit form for the incredible price of just \$79.95.\* It's the same, full-featured computer, only you put it together yourself. We'll send complete, easy-to-follow instructions on how you can assemble your ZX81 in just a few hours. All you have to supply is the soldering iron.

### A leader in microelectronics.

The ZX81 represents the latest technology in microelectronics. More than 10,000 are sold every week. In fact, the ZX81 is the fastest selling personal computer in the world.

We urge you to place your order for the ZX81 today.

### To order.

To order, simply call toll free. Or use the coupon below. Remember, you can try it for 10 days at no risk.\*\* The sooner you order, the sooner you can start enjoying your own computer.

### Call toll free 800-543-3000.

Ask for operator #509.  
In Ohio call: 800-582-1364;  
in Canada call: 513-729-4300.  
Ask for operator #509. Phones open 24 hours a day, 7 days a week. Have your MasterCard or VISA ready.

These numbers are for orders only. If you just want information, please write: Sinclair Research Ltd., 2 Sinclair Plaza, Nashua, NH 03061.

\*Plus shipping and handling. Price includes connectors for TV and cassette, AC adaptor, and FREE manual.

\*\*Does not apply to ZX81 kits.



**NEW SOFTWARE:** Sinclair has published pre-recorded programs on cassettes for your ZX81. We're constantly coming out with new programs, so we'll send you our latest software catalog with your computer.



**16K MEMORY MODULE:** Like any powerful, full fledged computer, the ZX81 is expandable. Sinclair's 16K memory module plugs right onto the back of your ZX81. Cost is \$49.95, plus shipping and handling.

# sinclair

## To order call toll free: 800-543-3000

Ad Code	09BYOS	Price*	Qty.	Amount
ZX81		\$99.95		
ZX81 Kit		79.95		
16K Memory Module		49.95		
Shipping and Handling		4.95		\$4.95
TOTAL				

**MAIL TO:** Sinclair Research Ltd.,  
One Sinclair Plaza, Nashua, NH 03061.

Name \_\_\_\_\_

Address \_\_\_\_\_

City \_\_\_\_\_ State \_\_\_\_\_ Zip \_\_\_\_\_

\*U.S. dollars



Topic Key	Sequence Key	Possible Meaning
3	1	oil the chair
3	2	bad brakes
4	2	tie is choking; belt is tight
5	2	chair won't move
29	2	bone, joint pains
7	3	philosophy of religion
29	3	coccyx and seating problems
29	4	breathing, diaphragm problem
5	1	eating plans for a trip
60	6	no water in wheelchair battery
7	1	eating preferences; I'm a vegetarian.
29	8	head
29	9	eye problems
—	10	next sentence theme will differ
10	—	clear buffer; start a new topic
20	—	tag questions; "He's gone, isn't he?"
30	—	changes negative context to positive
50	—	change to typewriter mode
60	—	electrical control; telephone dialer, TV switches

**Table 2:** To generate a sentence, the user must hit a key twice to set the topic, and then hit one or more keys to select a sentence pertaining to the topic. For example, if the user hits key #3 twice to set the topic and follows that by hitting key #1, a sentence pertaining to oiling the chair would be generated. The information in this table corresponds to the keys pictured in figure 2.

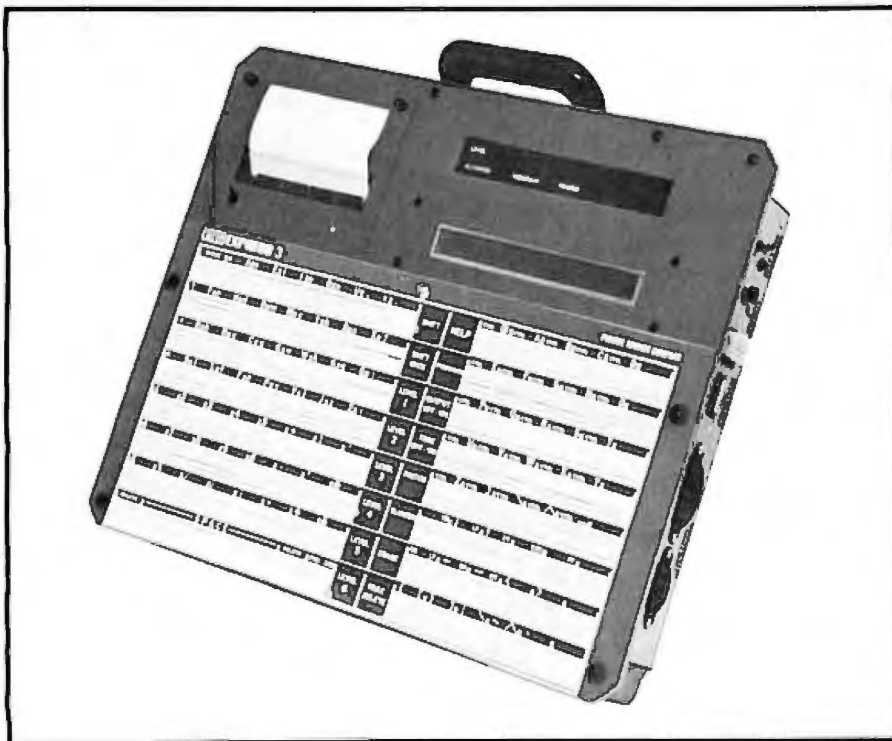

**Photo 2:** The Express 3, developed by Prentke Romich Co., is a portable communication aid powered by internal rechargeable batteries and designed for mounting on a wheelchair. A special Express 3 is being prepared to implement the Minspeak concept. The system will use a combination of power-strobed EPROM and CMOS RAM. A Votrax Speech PAC with an SC-01 voice synthesizer marketed by Vortex will be coupled to the output of the microprocessor. It will retain other features of the original Express 3, including a 40-character upper- and lowercase liquid-crystal display with corresponding thermal printer and serial ASCII output for connection to other computers and environmental-control devices.

vocabulary and social tone of the stored sentences.

### Considering the Possibilities

If you had 1000 sentences carefully constructed to cover most of the typical activities in your day, perhaps 75 percent of your utterances would be included in that group. Imagine adding 3000 more sentences composed to express a wide range of statements and questions concerning emotion and personal goals. If you then added another 1000 sentences which included statements of courtesies, greetings, thank yous, and you're welcomes, you would have enough sentences to cover most of the routine contingencies of life.

If communication-aid users could access any of these sentences with a few physical responses, their expressive difficulties would be on the road to resolution. Actual field work has shown that the number of sentences whose sequences can be easily remembered and used is unexpectedly high, perhaps approaching the thousands for a large percentage of potential users.

Minspeak is currently under development at the Prentke Romich Co. in Shreve, Ohio. PRC is working on the development of expressive communication aids for the severely physically disabled. A demonstration prototype of Minspeak will be available from the company later this year. Until now, the effectiveness of communication aids has caused agencies to question their definition as a prosthesis and this has limited the amount of outside funding available. Because of the advances represented by Minspeak, a coordinated multi-state legal campaign has been launched to persuade private and public health care funding agencies to make funding available for purchase of this device.

People who hear and cannot speak have an enormous potential for contributing to society through their insights into human communication. It is my sincerest hope that Minspeak will give them access to modern technology that will enable them to make this contribution in an easier and more productive way. ■



# MVP-FORTH

## A Public Domain Product



ORDER TODAY!!!

In keeping with the public domain release of FORTH by its inventor, Charles Moore, and the promotion of the language by the FORTH Interest Group, MVP-FORTH (for Mountain View Press) and the companion book, ALL ABOUT FORTH, are also placed in the public domain and may be used freely without restriction.

MVP-FORTH contains a kernel for transportability, the FORTH-79 Standard Required Word Set, the vocabulary for the instruction book, STARTING FORTH, by Brodie, editor, assembler, many useful routines, and utilities.

### MVP-FORTH PRODUCTS

- MVP-FORTH Programmer's Kit including disk with documentation, ALL ABOUT FORTH, and STARTING FORTH. Assembly source listing versions. \$100
- MVP-FORTH Disk with documentation. Assembly source listing version. \$75
- MVP-FORTH Cross Compiler with MVP-FORTH source in FORTH. \$300
- MVP-FORTH Programming Aids for decompiling, callfinding, and translating. \$150
- MVP-FORTH Assembly Source Printed listing. \$20
- ALL ABOUT FORTH by Haydon. \$20

\*\*\* MVP-FORTH operates under a variety of CPU's, computers, and operating systems. Specify your computer and operating system. \*\*\*

### MORE FORTH DISKS

**fig-FORTH Model and Source**, with printed Installation Manual and Source Listing.

- APPLE II<sup>®</sup>, 5 1/4"  8080/Z80<sup>®</sup>, 8"
- 8086/88, 8"  H89/Z89, 5 1/4"

\$65 Each

FORTH with editor, assembler, and manual. \*Source provided. Specify disk size!

- |   |   |
|---|---|
| <input type="checkbox"/> APPLE III/II + by MicroMotion \$100                  | <input type="checkbox"/> PET <sup>™</sup> by FSS \$90                                 |
| <input type="checkbox"/> APPLE II by Kuntze <sup>®</sup> \$90                 | <input type="checkbox"/> TRS-80/II <sup>™</sup> by Nautilus Systems <sup>®</sup> \$90 |
| <input type="checkbox"/> ATARI <sup>™</sup> by PNS \$90                       | <input type="checkbox"/> 6800 by Talbot Microsystems \$100                            |
| <input type="checkbox"/> CP/M <sup>™</sup> by MicroMotion \$100               | <input type="checkbox"/> 6809 by Talbot Microsystems \$100                            |
| <input type="checkbox"/> CROMEMCO <sup>™</sup> by Inner Access \$100          | <input type="checkbox"/> Z80 by Laboratory Microsystems \$50                          |
| <input type="checkbox"/> HP-85 by Lange <sup>®</sup> \$90                     | <input type="checkbox"/> 8086/88 by Laboratory Microsystems \$100                     |
| <input type="checkbox"/> IBM-PC <sup>™</sup> by Laboratory Microsystems \$100 |   |

Enhanced FORTH with: F-Floating Point, G-Graphics, T-Tutorial, S-Stand Alone, M-Math Chip Support, X-Other Extras, 79-FORTH-79. Specify Disk Size!

- |  |  |
|--|--|
| <input type="checkbox"/> APPLE III/II + by MicroMotion, F, G, & 79 \$140 | <input type="checkbox"/> TRS-80/II or III by Miller Microcomputer Services, F, X, & 79 \$130 |
| <input type="checkbox"/> CP/M by MicroMotion, F & 79 \$140               | <input type="checkbox"/> 6809 by Talbot Microsystems, T & X \$150                            |
| <input type="checkbox"/> H89/Z89 by Haydon, T & S \$250                  | <input type="checkbox"/> Z80 by Laboratory Microsystems, F & M \$150                         |
| <input type="checkbox"/> H89/Z89 by Haydon, T & S 175                    | <input type="checkbox"/> 8086/88 by Laboratory Microsystems, F & M \$150                     |
| <input type="checkbox"/> PET by FSS, F & X \$150                         |  |

**CROSS COMPILERS** Allow extending, modifying and compiling for speed and memory savings, can also produce ROMable code. \*Requires FORTH disk.

- |   |  |
|---|--|
| <input type="checkbox"/> CP/M \$200                   | <input type="checkbox"/> IBM <sup>®</sup> \$300  |
| <input type="checkbox"/> H89/Z89 \$200                | <input type="checkbox"/> 8086 <sup>®</sup> \$300 |
| <input type="checkbox"/> TRS-80/II \$200              | <input type="checkbox"/> Z80 <sup>®</sup> \$200  |
| <input type="checkbox"/> Northstar <sup>®</sup> \$200 | <input type="checkbox"/> 6809 \$350              |
- fig-FORTH Programming Aids for decompiling, callfinding, and translating. \$150

### FORTH MANUALS, GUIDES, & DOCUMENTS

- |  |  |
|--|--|
| <input type="checkbox"/> FORTH Encyclopedia by Derick & Baker. A complete programmer's manual to fig-FORTH with FORTH-79 references. Flow charted \$25 | <input type="checkbox"/> Starting FORTH by Brodie. Best instructional manual available (soft cover) \$16 |
| <input type="checkbox"/> 1980 FORML Proc. \$25   | <input type="checkbox"/> Starting FORTH (hard cover) \$20  |
| <input type="checkbox"/> 1981 FORML Proc. 2 Vol. \$40  | <input type="checkbox"/> METAFORTH by Cassidy. Cross compiler with 8080 code \$30                        |
| <input type="checkbox"/> 1981 Rochester Univ. Proc. \$25   | <input type="checkbox"/> Systems Guide to fig-FORTH \$25   |
| <input type="checkbox"/> Using FORTH \$25  | <input type="checkbox"/> Caltech FORTH Manual \$12   |
| <input type="checkbox"/> A FORTH Primer \$25   | <input type="checkbox"/> Invitation to FORTH \$20  |
| <input type="checkbox"/> Threaded Interpretive Languages \$20  | <input type="checkbox"/> PDP-11 FORTH User's Manual \$20   |
| <input type="checkbox"/> AIM FORTH User's Manual \$12  | <input type="checkbox"/> CP/M User's Manual, MicroMotion \$20  |
| <input type="checkbox"/> APPLE User's Manual MicroMotion \$20  | <input type="checkbox"/> FORTH-79 Standard \$15  |
| <input type="checkbox"/> TRS-80 User's Manual, MMSFORTH \$19   | <input type="checkbox"/> FORTH-79 Standard Conversion \$10   |
|  | <input type="checkbox"/> Tiny Pascal in fig-FORTH \$10   |

Installation Manual for fig-FORTH, contains FORTH model, glossary, memory map and instructions \$15

Source Listings of fig-FORTH, for specific CPU's and computers. The Installation Manual is required for implementation. Each \$15

- |                               |                                  |                               |  |
|-------------------------------|----------------------------------|-------------------------------|--|
| <input type="checkbox"/> 1802 | <input type="checkbox"/> 6502    | <input type="checkbox"/> 6800 | <input type="checkbox"/> AlphaMicro    |
| <input type="checkbox"/> 8080 | <input type="checkbox"/> 8086/88 | <input type="checkbox"/> 9900 | <input type="checkbox"/> APPLE II      |
| <input type="checkbox"/> PACE | <input type="checkbox"/> 6809    | <input type="checkbox"/> NOVA | <input type="checkbox"/> PDP-11/LSI-11 |

Ordering Information: Check, Money Order (payable to MOUNTAIN VIEW PRESS, INC.), VISA, MasterCard or COD's accepted. No billing or unpaid PO's. California residents add sales tax. Shipping costs in US included in price. Foreign orders, pay in US funds on US bank, include for handling and shipping by Air: \$5 for each item under \$25, \$10 for each item between \$25 and \$99 and \$20 for each item over \$100. Minimum order \$10. All prices and products subject to change or withdrawal without notice. Single system and/or single user license agreement required on some products. DEALER & AUTHOR INQUIRIES INVITED

THE FORTH SOURCE<sup>™</sup>  
MOUNTAIN VIEW PRESS, INC.

PO BOX 4656

MOUNTAIN VIEW, CA 94040

(415) 961-4103

# FDA Regulation of Computerized Medical Devices

*What designers of medically related hardware and software should know.*

---

Joseph Jorgens III  
Carl W. Bruch  
Frank Houston  
Bureau of Medical Devices  
Food and Drug Administration  
8757 Georgia Ave.  
Silver Spring, MD 20910

---

Most people know that when a device is used for medical purposes, it falls under the jurisdiction of the Food and Drug Administration (FDA) of the U.S. Public Health Service. Now, with the advent of the microprocessor, many existing medical devices have become computerized, and new medical equipment is being designed with microprocessors. Consequently, many hardware and software producers may be required by law to notify the FDA of their medical devices. And those designing such devices or producing software for medical purposes should be aware of the regulations and the manufacturing controls that must be followed in order to comply with the Medical Device Amendments of 1976.

## The Law

The Medical Device Amendments of 1976 to the Federal Food, Drug, and Cosmetic Act gave the FDA the responsibility and authority to assure that medical devices are safe and effective.

As defined by the amendments, a

medical device is an "instrument, apparatus, implement, machine, contrivance, implant, in vitro reagent, or other similar or related article, including any component, part or accessory, which is intended for use in the diagnosis of disease or other conditions, or in the cure, mitigation, treatment, or prevention of disease,

---

**Many hardware and software producers may be required by law to notify the FDA of their medical devices.**

---

in man or other animals, . . . which does not achieve any of its principal intended purposes through chemical action within or on the body."

## Levels of Control

The amendments provide three levels of controls to assure the safety and effectiveness of medical devices. They are Class I, devices requiring general controls; Class II, those re-

quiring specific performance standards; and Class III, those requiring premarket approval. Medical devices such as bedpans and surgical instruments for which general controls are adequate to ensure safety and effectiveness fall into the Class I category. General controls prohibit adulteration and misbranding of a medical device. Under the amendments, adulteration may include failure to follow Good Manufacturing Practice Regulations, comply with an FDA standard for a device, or submit a premarket approval application. Misbranding may include failure to register production facilities, list a device, or properly label the medical device, e.g., by not providing adequate directions for use. Labeling is not confined to the label on the device itself but may include any literature accompanying the device, operating or service manuals, and advertisements for the device.

Class II products require a specific performance standard, as well as the general controls, in order to provide reasonable assurances of safety and effectiveness. For example, devices such as those that make measure-

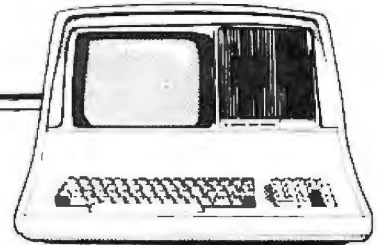
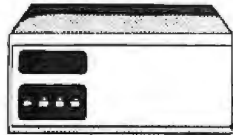

# SuperBrain II™ CompuStar™ Network Systems

- Excellent Dealer & EOM Discounts
- CMC's own national on-site service
- Module replacement
- Advertising co-op program
- Toll-free hotline
- Buy from the best—we're the oldest and largest distributor of Intertec products, serving our world-wide dealer network for many years.
- **Systems include:**
  - Microsoft Basic - CP/M 2.2 DOS
  - 350K, 700K or 1.4MB storage
  - Battery-operated real time clock
  - Graphics capability - Dual RS232 ports
  - Supports Basic, Fortran, Pascal, Cobol, PL/1 80

## CMC ALSO OFFERS

- Six-month warranty
- Green phosphor screen option
- Enhanced DOS with advanced files directory, disk editor, diagnostics, communications software and others
- High resolution graphics

## CompuStar Hard Disk Systems

10mb, 32mb & 96mb

Control Data Corp.  
9448-96 CMD  
and  
9448-32

**BEST PRICES  
ANYWHERE!**

## SOFTWARE, PERIPHERALS FOR SUPERBRAIN COMPUSTAR

SOFTWARE		PRINTERS	MODEMS	MISC.
Accounting Plus	Microsoft	Datasouth	Anderson-Jacobson	Line Filters
Wordstar	MBasic	Epson	CAT Novation	Power Supplies
dBase II	Fortran 80	C. Itoh	<b>HARD DISKS</b>	
Condor	Cobol 80	Okidata	CMC Targa	
Microplan	M/T Pascal	Infoscrite	Corvus	
Profitplan	P/L1 80	NEC	<b>MEDIA</b>	
Bisynch 80	Spellguard	Starwriter	Dysan	
CBasic II	Spellstar	F10	Verbatim	

DEALER INQUIRIES, GSA, GOVERNMENT, EDUCATIONAL BIDS INVITED



For Information Call (206)453-9777  
To Order, Call Toll-free 1-800-426-2963

# CMC

A Division of Computer Marketing Corporation

11058 Main Street, Suite 220  
Bellevue, Washington 98004  
TELEX: 152556 SEATAC

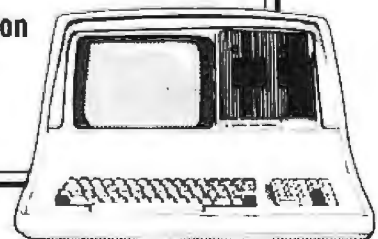
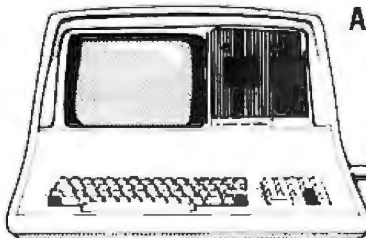

See us at Comdex Booth 4128.

SuperBrain and CompuStar are registered trademarks of Intertec Data Systems Corporation

# Butch Brown believed "logic seeking heads" lived in the hippie district.

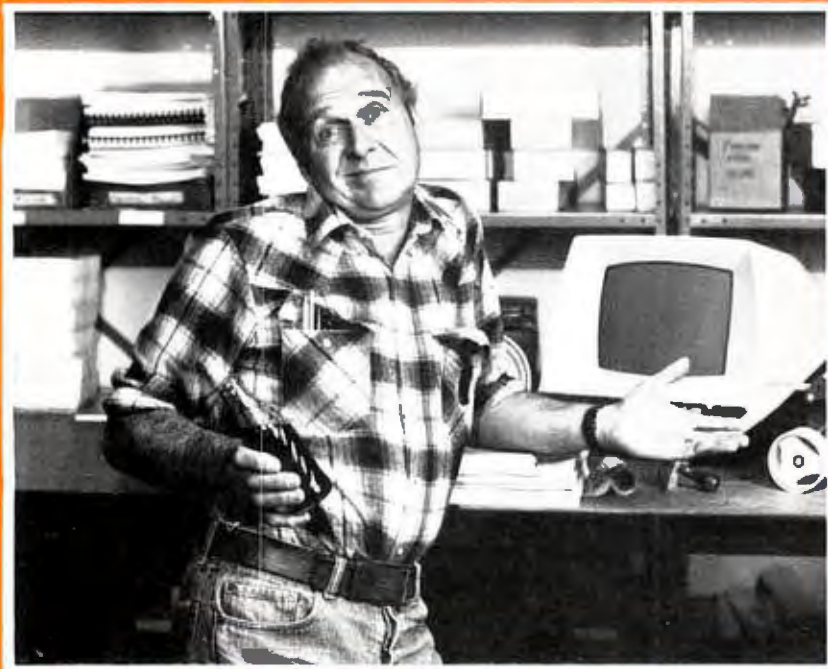

## Until he became an Orange Micro Printer Expert.

**Printers Can Be Confusing.** Sometimes, even the informed personal computer owner is caught short by the mound of technical differences in printers. After one visit to Orange Micro, Butch learned a logic-seeking print head skips over blank spaces and seeks the fastest path to the next printable character—for quick stock record printouts.

### We Educate

**First.** With so many different printers out there with as many different features, we feel a printer education is in order. We take what you already know about computers and explain printers in the same terms. Our current customers seem to like that because of the friends they refer. (Nearly 50% of our business is referral.)

**It's Easy To Be An Expert.** Orange Micro printer specialists are there to make you feel comfortable with your newfound printer knowledge. And when you decide on the printer right for you, you'll know exactly why you picked it from all the rest. With over 35



popular models to choose from, and a complete selection of cables, options and interface accessories, we have everything you need to get your new printer up and operating in minutes.

**We Have The Right Printer For You.** Bring along your toughest printer questions. Our salespeople will answer them honestly and practically. In less time than you'd imagine possible, you'll be a printer expert too! After all, printers are our only business, so we always do a better job at finding the right one for you.

### Orange Micro Printer Stores

3150 E. La Palma, Suite I  
Anaheim, CA 92806 (714) 630-3622

13604 Ventura Boulevard  
Sherman Oaks, CA 91423 (213) 501-3486

3216 Scott Boulevard  
Santa Clara, CA 95051 (408) 980-1213

1104 Van Ness  
San Francisco, CA, 94109 (415) 673-0170



Limited Franchise Opportunities Now Available. Call (714) 630-3620

Circle 353 on inquiry card.

ments or amplify physiological signals fall into this category. The amendments gave the FDA authority to establish mandatory performance standards for these products. Equipment such as electrocardiographs, blood-pressure meters, and medical thermometers are in Class II. Class II also contains some devices whose use entails some risk for the patient, such as defibrillators and electrical nerve stimulators.

A Class III device is one that may pose a significant risk to health from its use and for which there is insufficient information available to develop a performance standard. This would be the case, for instance, in new measurement techniques, new treatments, or artificial organs. Many implantable devices are in this class. In order to bring a Class III medical device to market, a manufacturer must demonstrate to the FDA that the device is safe and effective. The results from animal studies, clinical trials, and in vitro studies for the medical device are submitted in a pre-market approval application to the FDA for review.

In the FDA, the Bureau of Medical Devices has the primary responsibility for regulating medical devices as defined above. Several working groups within the Bureau are charged with carrying out different provisions of the act. Medical device manufacturers usually interact with the Office of Compliance, the Office of Device Evaluation, or one of the FDA's field offices.

The Office of Compliance is responsible for assuring good manufacturing practices as well as administering recalls and examining any violations of the act. Legal actions such as seizures, injunctions, and prosecutions are also part of its activities. Manufacturers who bring a new device to market generally deal with the Office of Device Evaluation, which is divided into seven medical specialty groups. (For this discussion, the term *manufacturers* will include producers of both software and hardware.) Advisory panels composed of experts from outside the FDA assist each division in its specialty area.

Circle 213 on inquiry card. →

Four times faster than any 300 bps modem, to be precise. With Hayes Smartmodem 1200, any computer with an RS-232C connection — such as the IBM Personal Computer, TRS-80® or Apple® III — can communicate over telephone lines with other computer terminals or printers. Smartmodem 1200 connects directly to any standard telephone jack in the USA. Dialing can be Touch-Tone® pulse or both. It can even operate over multiline phone systems (PBX) to dial numbers, receive and transmit data, and disconnect — automatically. An internal speaker lets you hear the call being made and monitor its progress. That way you'll know immediately if the line's busy or you reach a

wrong number. And indicator lights keep you posted on the current operating status: modem ready, terminal ready, carrier detect, auto-answer and high speed.

Smartmodem 1200 is two modems in one. Like the original Hayes Smartmodem, it can communicate with other Bell 103 type modems at up to 300 bps. Plus it's a 1200 bps modem for communicating with the faster Bell 212A type modems. Unlike many 1200 bps modems, Smartmodem 1200 lets you select full or half duplex, for compatibility with time-sharing services or any other system you choose. Smartmodem 1200 allows you to access The Source,<sup>SM</sup> communicate with

your branch offices, or exchange programs with other computer users. In fact, it performs just about any communication function you can imagine, and can be program controlled using any language.

Smartmodem 1200. Another product in the Hayes Stack™ series that stands for quality and dependability. And all you need for communicating... fast! Available at computer stores nationwide. For the name of your nearest dealer write: Hayes Microcomputer Products, Inc., 5835 Peachtree Corners East, Norcross, Georgia 30092; or call (404) 449-8791.



## Smartmodem 1200. Gets you moving fast!



# Hayes

™ Trademark of Hayes Microcomputer Products, Inc. ©1982 Hayes Microcomputer Products, Inc. Sold only in the U.S.A. TRS-80 is a registered trademark of Tandy Corporation. Apple is a registered trademark of Apple Computer, Inc.

Touch-Tone is a registered trademark of American Telephone and Telegraph. The Source is a service mark of Source Telecomputing Corporation, a subsidiary of The Reader's Digest Association, Inc.

# THE EPROM PAC-MAN HAVE ROOM FOR

Presenting the Intel 27128.

The biggest EPROM in the world—able to take 16K bytes (or 128K bits) of software in a single gulp.

But enough with the introductions.

The fact is now it makes sense to put application and system software—once reserved for floppies—on an EPROM instead.

Why?

A lot of reasons.

You can make a computer less of a computer for people using it. Operating systems, compilers and application software can all be pressed into action with one easy-to-remember pushbutton instead of 15 or so

computer startup procedures.

You can make a computer react faster. Compared to software stored on a floppy, 80 times faster. Or faster than Blinky can wipe out your man.

You can also make a computer more reliable. Since Intel EPROMs have the MTBF to keep going 600 times longer than floppies.

Yet you're not locked into a program for life. Unlike its ROM counterparts, an EPROM is meant to be changed.

And even though the 27128 EPROM can help shrink your system, you have all the room you need. So the CPM operating



# THAT CAN EAT AND STILL SPACE INVADERS.

system can fit in one chip. And a BASIC interpreter in one.

Of course, you get all the other no-nonsense advantages of an Intel EPROM. JEDEC-approved bytewise pinouts for easy upgrades. The 0.1% AQL that made our 2764 a world standard. And the immediate availability for non-stop production of your system.

All this without blowing your systems costs out of the water. Because as sure as an EPROM has 28 legs, the 27128 EPROM will set a new low for cost per EPROM bit within the next year.

After all, the way we see it, the way to

make software friendlier is to make it hard.

To see how our 27128 software carrier can improve your game plan, contact your local distributor or Intel Corporation, 3065 Bowers Avenue, Santa Clara, CA 95051. (408) 987-8080.

**intel** delivers  
solutions

United States and Canadian Distributors: Alliance, Almac/Strom, Arrow Electronics, Avnet Electronics, Component Specialties Inc., Hamilton/Avnet, Hamilton Electro Sales, Harvey, L.A. Varah, Measurement Technology Inc., Mesa, Pioneer, Wyle Distribution Group, Zentronics. In Europe and Japan, contact your local Intel sales office.

PAC-MAN is a trademark of NAMCO-America, Inc. Space Invaders is a trademark of Taito America Corporation. CP/M is a registered trademark of Digital Research, Inc.

Circle 239 on Inquiry card.

Device evaluation is concerned with new products that will be placed in commercial distribution. Products that are new, those that have been "significantly modified," and "me-too" products (copies of devices already on the market) from a new manufacturer require a premarket notification from the manufacturer 90 days prior to marketing the device. The premarket notification is called a 510(k) submission since it is required by regulation 510(k) of the Federal Food, Drug, and Cosmetic Act. During this 90-day period, the appropri-

ate Device Evaluation division reviews the premarket notification and determines whether or not the product is substantially equivalent to a device that was in commercial distribution before May 28, 1976, the date on which the Medical Device Amendments became law. If the product is substantially equivalent, it may be commercially distributed. A product that is not substantially equivalent to a pre-amendments device, and which has not been reclassified, is placed in Class III and requires a premarket-approval ap-

plication that is reviewed by FDA staff as well as by the advisory panel to determine whether the safety and effectiveness of the device have been demonstrated. If they have, the product will be allowed into commercial distribution.

### Computers and Medical Devices

With the advent of microprocessors came two developments for medical devices. First, microprocessors began to replace discrete components, and second, totally new devices became possible. The first development augments the reliability of medical devices and also allows great flexibility without the necessity for major hardware design changes. The second development arises from the ability to implement very complex logical decision schemes with a relatively inexpensive piece of hardware. In addition, the proliferation of personal computers and associated software allows individuals to produce small, very intelligent medical devices and medical software.

Microprocessors that are components of medical devices or of large computing systems that interface with medical instruments are normally considered medical devices. Software that is written for such systems may be classified as a medical device. By identifying the purpose of the system and the function of the software within the system, you can determine if your hardware and software are medical devices.

### Hardware

Products that apply the latest technology (often using microprocessors) to perform the functions of discrete component designs will not be regulated in a manner significantly different from their predecessors if the use of the microprocessor does not change the medical nature of the product. Consider, for instance, the electrocardiogram monitor, which has evolved from electron tubes, to transistors, to integrated circuits, and finally to microprocessors. The hardware and software of the latest generation of monitors are regulated to the same extent as the tube model was, as long as the two generations of



## The DS120 Terminal Controller makes your LA36 perform like a DECwriter® III.

The Datasouth DS120 gives your DECwriter® II the high speed printing and versatile performance features of the DECwriter® III at only a fraction of the cost. The DS120 is a plug compatible replacement for your LA36 logic board which can be installed in minutes. Standard features include:

- 165 cps bidirectional printing
- Horizontal & Vertical Tabs
- Page Length Selection
- 110-4800 baud operation
- 1000 character print buffer
- X-on, X-off protocol
- Self Test
- RS232 interface
- 20 mA Current Loop interface
- Top of Form
- Adjustable Margins
- Double wide characters
- Parity selection
- Optional APL character set

Over 5,000 DS120 units are now being used by customers ranging from the Fortune 500 to personal computing enthusiasts. In numerous installations, entire networks of terminals have been upgraded to take advantage of today's higher speed data communications services. LSI microprocessor electronics and strict quality control ensure dependable performance for years to come. When service is required, we will respond promptly and effectively. Best of all, we can deliver immediately through our nationwide network of distributors. Just give us a call for all the details.

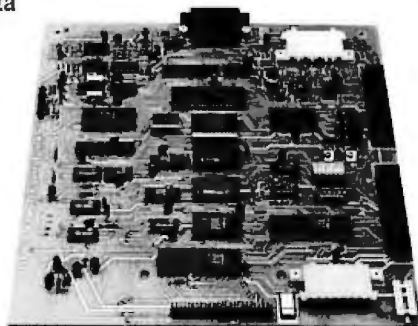

**datasouth computer corporation**

4216 Stuart Andrew Blvd. • Charlotte, North Carolina 28210 • 704/523-8500



monitors are substantially equivalent.

If a microprocessor in the monitor automates a process, say, by automatically infusing a drug when a certain electrocardiographic pattern is present, then the medical nature of the device may be considered changed. The monitor may be no longer primarily a provider of data; it might now be a maker of medical decisions, and if this device were the first of its kind, it might be regulated as a new (Class III) device.

### Software

The subject of software is a bit more complex. Software gives medical devices flexibility and can be portable from one computer system to another. For the sake of simplification, consider four software categories:

1. software that is permanently installed in a specific medical device

not intended to be altered by the user and required for the device to function

2. software that may be temporarily installed in a specific medical device with the capacity to alter the function or performance of the device

3. software designed for use on a single, general-purpose computer (that is, a computer not specifically dedicated to one particular device)

4. software designed for use on multiple, general-purpose computers

**Category 1.** In this case, the software is really a fixed component of the instrument. If the instrument is a medical device, so is the software. The level of control will be governed by the device function or purpose of the instrument.

**Category 2.** This software is a replaceable component, somewhat like a phonograph record. It may change the performance of the instru-

ment and make it function as a different medical device. Again, if the instrument operates as a medical device, the software enabling such operations will also be considered a medical device.

**Category 3.** Suppose a software package is developed for one mini-computer system that might accept EKGs from a 10-bed intensive care unit, analyze the electrocardiograms, and make a diagnosis of the patients' heart conditions. This would fall into Category 3. Because it accepts data from a patient and makes a diagnosis, it falls within the definition of a device and is subject to regulation.

**Category 4.** Category 4 would apply to a package developed in one of the high-level languages such as FORTRAN, BASIC, or Pascal. Categories 3 and 4 contain gray areas with respect to the medical-device definitions. If someone takes several medical textbooks, develops a decision process leading to a diagnosis,

## HONORABLE...

Introducing the Honorable Shell—

## OKARA™

A true breakthrough in operational technology for CP/M™ systems.

OKARA lets you, the user, create command scripts to replace the boring, repetitive, error-prone keyboard dialogs normally required by CP/M and the programs that run under it. With OKARA the machine presents any personality you design, from simple cryptic commands that do it all to elaborate, hand-holding menus. OKARA is a must for anyone who uses CP/M. And a super-must for system integrators, software developers, office managers, teachers, parents... anyone who sets up CP/M applications for others.

**Fast**—20 to 100 times faster than SUBMIT, SUPERVYZ™ or STOK PILOT™.

**Tiny**—Typically under 4.5K with all modules loaded, plus 2K for CCP.

**Smart**—You can use it like SUBMIT, or program it to create your own menus or other dialogs.

**Simple**—If you use CP/M, you can learn OKARA in an hour or less.

**Slick**—Provides some enhancements that CP/M has always needed.

**Friendly**—In so many ways. One example, OKARA can page console output from any program or command. No more racing to type a control-S.

**Universal**—Nearly all present and future CP/M applications will run under OKARA without modification.

**Price**—\$150, single copy. \$130, disk only. \$20, manual only. OEM discounts available. Calif. residents add sales tax.

**Formats**—8" single density, 5" Osborne, Apple, Northstar.

**System**—8080, Z80, or 8085 cpu, CP/M 2.2 Operating System. Text editor to create scripts.

**KIAI**  
systems

P.O. Box 11461  
Oakland, CA 94611  
(415) 654-8671

\*OKARA is a trademark of KIAI Systems. SUPERVYZ is a trademark of ERIC Computer Corporation. STOK PILOT is a trademark of STOK Computer Interface. CP/M is a trademark of Digital Research.

# The Dynamic Duo from

## 20 Megabyte Hard Disk Sub-Systems for Under \$3500!

Our Systems Are Compatible with Your

TRS-80® Model I, II, III, XVI

Apple II®

IBM® PC

NEC™

S-100™

Altos™

NorthStar™

Superbrain™

Panasonic™

Epson™

Heath/Zenith™

and Others

Now  
Available!  
Optional  
10 Meg.  
Tape  
Back-up

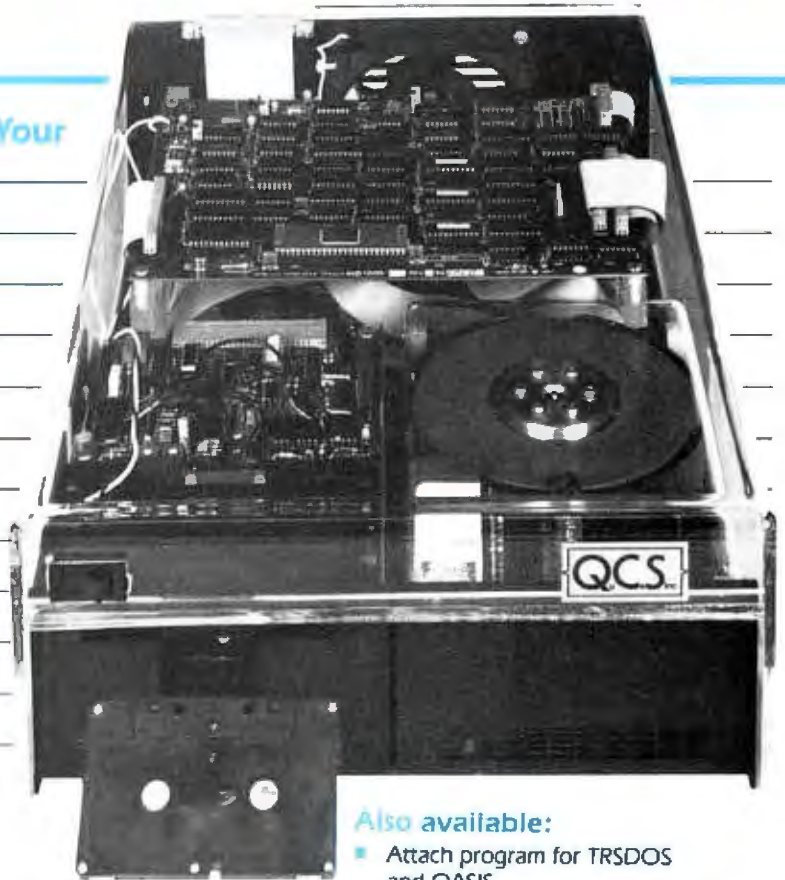

Now you can expand the capability of your microcomputer with cost-effective mass storage from Q.C.S. Our integrated family of 6-, 12-, 20-, and 40-million-byte systems lets you operate your micro with the speed, convenience, and proven reliability of systems costing thousands of dollars more! And as your needs grow, Q.C.S. mass storage can grow too. You can start with an entry-level 6-million-byte system and expand 80 million bytes ... without scrapping your existing programs or operating system.

**The completely assembled and tested system includes:**

- Switching power supply
- Winchester drive

- Host adapter card
- Sealed case
- Expansion (enclosure, controller, and power supply designed for future backup hardware or increased storage)
- Software
- Auto-attach CP/M
- Hard disk utilities
- Realtime clock
- Formatting program (assigns alternates for any weak sectors detected during formatting—assuring the lowest possible error rate)
- Warranty (a full one-year warranty on all parts and workmanship)

**Also available:**

- Attach program for TRSDOS and OASIS
- **New CP/M dynamic generator:** configured software; menu-driven for 6-, 12-, 20-, 40-, 80-megabyte drives

**The following systems software can be utilized:**

TRS I, III—attach software for DOS 4.0,\* LDOS

TRS II, XVI—CP/M Racet for TRSDOS,\* Turbo DOS, OASIS

TRS Models II and XVI use 6 Meg for CP/M and 6 Meg for TRSDOS.

Apple—CP/M and DOS 3.3

NEC—CP/M

S-100—CP/M

Heath/Zenith—CP/M

IBM—PC DOS, USCD, etc.

\* Available at an additional cost.

**Q.C.S.**  
u e t i n c

# Quality Computer Services

## BIG BLUE SuperCharger

for Your IBM PC with Over 35% More Power and Throughput Than a Standard 4MHz Z80 System!

### Here's what BIG BLUE includes:

- Dual Access I/O
- Allows for Dual Processing
- Serial port and parallel port
- Ability to run existing CP/M-80 programs
- Z80B microprocessor running at 5.5 MHz
- 64K memory
- Hard disk interface
- Calendar clock

ALL FOR ONLY \$595.00

The all-on-one board all in one slot

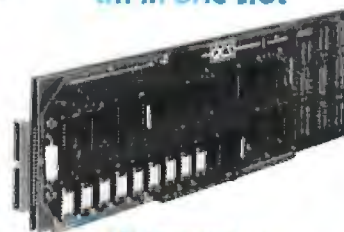

still leaves you room for expansion.

BIG BLUE gives your IBM PC more memory capacity and expandability

Plug in BIG BLUE and get a computer-within-a-computer

BIG BLUE, an auxiliary processor PC board for your IBM Personal Computer, lets you run thousands of programs written for the CP/M operating systems.

CP/M has been around since 1975, and contains some of the most sophisticated, proven programs ever written.

The immense library includes time managers, spreadsheet manipulators, and office packages. Languages contained are BASIC, ALGOL, FORTRAN, C, PASCAL, COBOL, PILOT, and many others.

Edit and format text. Check spelling and indexes. Discover the ease of word processing.

Enjoy games such as Chess, Adventure, and Star Trek.

Let your imagination run wild! Put BIG BLUE to the test.

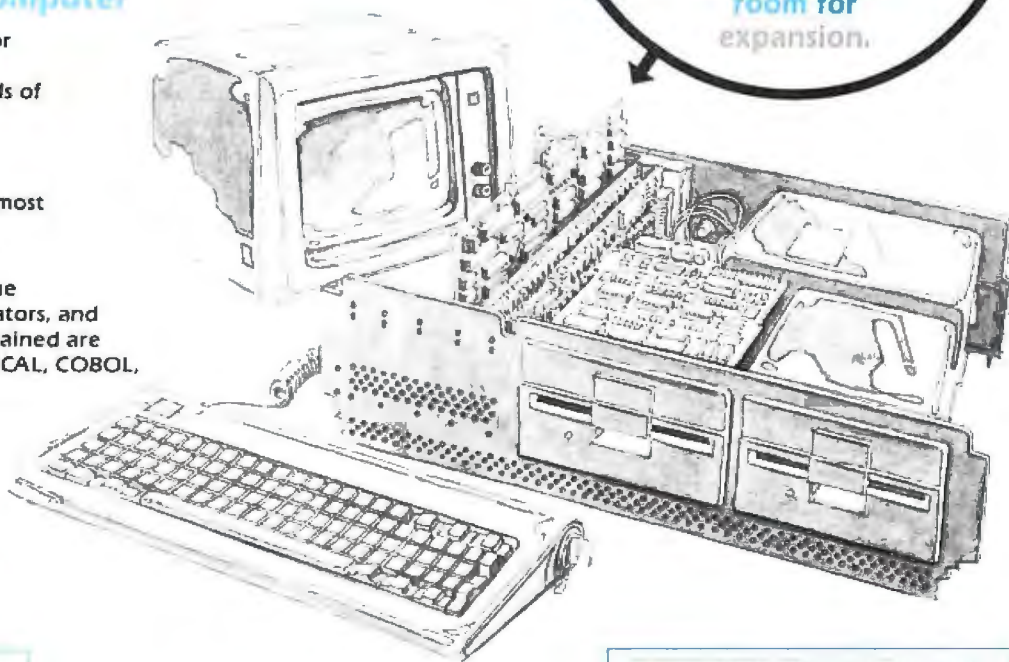

### AVAILABLE SOON! UNIVERSAL DISK CONTROLLER

- For 5 1/4" and 8" FLOPPY DISKS
- Single Density/Double Density
  - Single Side/Double Side

Quantity discounts available. Dealer and OEM inquiries invited.

### WARRANTY

One full year on all parts and workmanship.

Quality Computer Services  
178 Main Street  
Metuchen, New Jersey 08840  
201/548-2135



Toll-free number: (800) 631-5944

and automates the process, is the resulting program a medical device? No definite decision has yet been made. Even if this automated process is considered a medical device, how should the Bureau of Medical Devices analyze the 510(k) submissions? Perhaps the appropriate method would be to ask whether the algorithm that is used is substantially equivalent to the algorithm that was employed manually. If the algorithm were the same, the computerized version of that process would be determined to be substantially equivalent to the manual version and would not be covered by Class III regulations.

As you may imagine, the issue of software as a medical device is complex and still in a state of flux. Perhaps some examples of software products that have already been examined by the Bureau of Medical Devices will provide some clarification.

One product that was reviewed by the Bureau of Medical Devices was a microprocessor-based monitor that

measured several patient parameters such as blood pressure and heart rate, manipulated those measured parameters, and displayed the measurements in both a real-time fashion and in a trend plot. The product, including its software, was considered to be a medical device.

Another product used hardware, leased or sold to a hospital, that measured pulmonary parameters. The raw data was sent to a computer by way of phone lines. The computer manipulated the raw data and returned a display of the patient's pulmonary functions to the hospital. Because the data manipulator and its software made claims for medical purposes and required the leased or purchased front-end hardware system, it was considered a medical device rather than a service and fell under the Bureau of Medical Devices regulations.

A new pulmonary-function analyzer uses an Apple II microcomputer to measure a patient's breathing with an electronic flowmeter, analyze

the information, and print out a graph of the patient's pulmonary function. This is considered a new medical device, but because it merely does the same analyses that were once done by hand, it was determined to be substantially equivalent to a pre-amendments device and was not placed in Class III.

Another firm uses a computer to analyze X rays and patient information received from hospitals to determine the patient's future growth statistics. Several X rays and a history of the patient are mailed to the company where the future growth parameters are predicted by way of a programmed algorithm. The Bureau of Medical Devices considered the firm a *service* provider, and although the programmed algorithm is a medical device, it is not subject to active regulation except for the regulations regarding misbranding and adulteration.

Products that fall into this limited level of regulation must meet the following criteria:

1. The product must be a computer software package essentially based on data-analysis methods appearing in the literature.
2. Only services provided by the software can be sold. The software itself can't be sold or leased to users or other service providers.
3. The data used as input by the software must be generated by a commercially available device.

In this instance, if the firm were to market the software package that guides the calculations, such a package would be an actively regulated medical device.

### Conclusion

This article has been a limited discussion of FDA regulation of computerized medical devices and medical software. Many details have been omitted. Designers of medical software and hardware should obtain additional information by contacting the Office of Small Manufacturers Assistance, Room 1431, 8757 Georgia Ave., Silver Spring, MD 20910 (301) 427-7184. ■

## S-100 USERS KNOW & ARE SPREADING THE WORD:

For any S-100 bus computer,  
the MM-103 is the modem to use!

In fact, most of our new sales are referrals from satisfied customers.

Here's why:

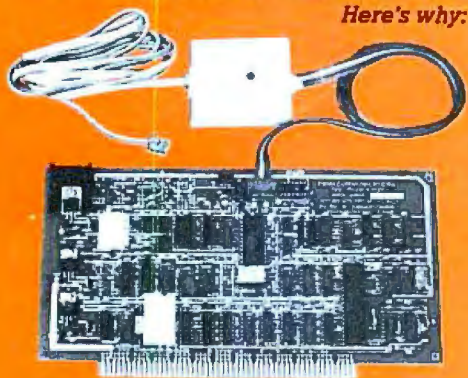

- The MM-103 is a direct connect, S-100 compatible, Bell 103 standard modem, with auto originate and auto dialing.
- MM-103 works with the widest variety of public-domain and commercial software, featuring selectable modes, parity and baud rates (61-600 baud) for unsurpassed flexibility.
- You can expect off-the-shelf, UPS-fast delivery. Order with check, VISA, MasterCard or COD.
- MM-103 is installed in minutes. A call to our 24 hour a day modem test center (703-379-0303 at 300 baud) allows immediate test & verification of operations.
- MM-103 comes with an unbeatable warranty with speedy repairs - a service needed by less than 5 percent of boards sold.

**TRY THE MM-103 FOR 10 DAYS!**

If you're not satisfied, return it for a full refund. But, if you find what others have discovered - that the MM-103 is tops in performance & reliability -

**SPREAD THE WORD!**



**COMMUNICATIONS**  
(Potomac Micro-Magic, Inc.)

5201 Leesburg Pike, Suite 604  
Falls Church, VA 22041  
(703) 379-9660

# INTRODUCING MORE REASONS FOR TRYING CONTROL DATA FLEXIBLE DISKS RIGHT NOW.

## 2 FREE IN EVERY BOX.

Now you have two more reasons to try Control Data flexible disks. Two free disks in every specially labeled box of 10 beginning July 1st. That's 12 disks, or 20% more in every box.

Control Data flexible disks are dependable. They're guaranteed error-free so you can count on them to perform time after time. We manufacture and test every disk to exacting standards. It's one reason many users choose our media above all others.

Control Data disks are available in both 8-inch and 5-1/4-inch sizes, in a variety of formats. And from now until Dec. 31, 1982, you get two free in every specially labeled box—just for trying them.

If there isn't a participating distributor near you, call toll-free 800-328-6207.

### DISTRIBUTORS

#### ARIZONA

Tucson, Specialty Computer Ribbons & Supplies  
602/293-6861

#### CALIFORNIA

Lodi, Visible Computer Supply  
209/334-9487

Los Angeles, The Supply Depot, Inc.  
213/873-6337

Orange, Data Bits, Inc.

714/833-6650

Orange County, The Supply Depot, Inc.  
714/750-1367

San Fernando Valley, The Supply Depot, Inc.  
213/704-7075

San Francisco, The Supply Depot, Inc.  
415/881-7800

Simi Valley, The Supply Depot Corp.  
805/583-0505

#### COLORADO

Denver, Data Pro Ltd  
303/777-8655

#### FLORIDA

Hialeah, KAR Printing  
305/557-4782

Miami, Data Pax  
305/446-9291

#### GEORGIA

Atlanta, Data Associates, Inc.  
404/252-9818

#### ILLINOIS

Chicago, Thomas Computer Corp.  
312/944-1401

St. Charles, Visible Computer Supply Corp.  
312/377-0990

#### IOWA

Cedar Rapids, Network Business Forms, Inc.  
319/365-8691

#### MARYLAND

Baltimore, The Supply Depot, Inc.  
301/252-4992

Gaithersburg, BASYS  
301/977-8900

Jessup, Data Storage, Inc.  
301/953-2424

#### MASSACHUSETTS

Woburn, Data Research Associates  
617/938-0425

#### MICHIGAN

Southfield, Transaction Storage Systems  
313/557-3036

#### MINNESOTA

Bloomington, Alanson Business Prod., Inc.  
612/881-1151

Minneapolis, Sexton Data Products

612/941-5880

#### MISSOURI

Hazelwood, Specialty Computer Ribbons & Supplies  
314/731-0808

#### NEW JERSEY

Engelwood, Data Research Associates  
201/569-2620

#### NEW YORK

New York, Data Research Associates  
212/564-2232

#### OREGON

Eugene, Western Paper Company  
503/688-8381

Jacksonville, Computer Exchange  
503/772-3803

Portland, Western Paper Company  
503/288-5646

#### OHIO

Columbus, Transaction Storage Systems  
614/221-1788

#### PENNSYLVANIA

Berwyn, Used Computer, Inc. (UCI)  
215/647-1881

#### TEXAS

Austin, Business Data Products  
512/453-5129

Dallas, Philbo Enterprises  
214/358-1200

Houston, Sunflex Data Supplies  
713/783-5270

San Antonio, Bull's I Data  
512/656-8367

San Antonio, Transcontinental Distrib.  
512/737-0064

#### UTAH

Salt Lake City, Rebel Enterprises, Inc.  
801/281-3300

#### VIRGINIA

Fairfax, Data Research Associates  
703/385-3414

#### WASHINGTON

Kent, Western Paper Company  
206/251-5300

Pasco, Western Paper Company  
509/547-1633



 CONTROL DATA

Circle 133 on Inquiry card.

# How to get your fir

You're not alone, you know.

We've all been through that same excruciating moment when we realized that we were going to have to learn a lot more than we wanted to know about programming, in self-defense.

But most of us survived.

Many of us with a little bit of help called dBASE II, the relational database management system (DBMS) for micros.

## The best defense is a strong offense.

Don't get seduced by BASIC, because basically BASIC is weak. And to make it do anything useful can take 10 times as much programming (and time) as with dBASE II.

dBASE II is much easier because it's a relational DBMS, and you control your information with powerful, English-like commands.

With a word or two, you CREATE databases, APPEND new data, UPDATE, MODIFY and REPLACE fields, records and entire databases. DISPLAY some or all of your data for any conditions you want to apply. Organize months worth of data in minutes with REPORT.

You can prepare your forms and formats precisely the way you want them. Do calculations on fields, records and entire databases with 10-place accuracy.

And do even more with dozens of other commands.

## Here's the catch.

With any language, you'll need to understand relational operators ("less than," "greater than," "equals") and a bit of logic ("or," "and," "not").

With dBASE II, you'll also get an easy way to make choices (IF..THEN..ELSE) and a powerful way to perform repetitive tasks (DO WHILE..).



With these tools, you're ready to tackle your accounting and time billing, project management, and any other data handling and record keeping. You can work interactively and get your answers right now. Or save your instructions and repeat everything with two words: DO Man-hours, DO ProjectX, DO whatever has to be done.

## Use dBASE II to help make your choice.

If you've got a 48k CP/M micro with a disk drive (96k IBM PC), send us \$700 (\$400 for a 56k Apple). We'll send you a copy of dBASE II to use free for 30 days.

# the best of st micro.



Instead of just poring over a manual, run it and make certain that dBASE II does what you need done.

Then if you find it isn't right for you, send it back and we'll return your money, no questions asked.

But we know that you'll probably keep it.

Because having dBASE II is like having a black belt in micros.

Call (213) 204-5570 today or drop by your local computer store for the rest of the story.

Ashton-Tate, 9929 Jefferson Blvd., Culver City, CA 90230.

## Ashton-Tate

© 1982 Ashton-Tate  
CP/M is a trademark of Digital Research

# Talking Terminals

*Text-to-speech translation involves looking at the problem from a different "viewpoint."*

---

David Stoffel  
Scion Corporation  
12310 Pinecrest Rd.  
Reston, VA 22091

---

Imagine for a moment that you are sitting in front of a computer video terminal working on a program when suddenly the screen goes blank. The display tube has failed. Could you continue to work on the program even though you couldn't see the screen display? That's exactly the problem that faces many visually disabled persons when they try to use standard microcomputers.

An answer to that problem is the "talking terminal." Simply, a talking terminal resembles a conventional computer terminal except that it speaks information instead of, or in addition to, displaying that information visually. This article aims to offer an understanding of the human factors involved in selecting a talking terminal and to compare current talking-terminal products.

---

#### About the Author

*David Stoffel has participated in the research and development of voice-response technology for six years. He has built his own talking terminal as a research tool and for his personal and professional use.*

---

In addition to conventional terminal capabilities, a talking terminal requires several additional features and capabilities. First, of course, the terminal must be able to talk intelligibly for you to understand its

---

**Speech is an elusive method of communication; once those sound waves are heard, it's up to the listener to remember what was said.**

---

speech. So, we want to assess the intelligibility and acceptability of the product's speech. Second, speech is an elusive method of communication; once those sound waves are heard, it's up to the listener to remember what was said. So, just as many video-display terminals provide local

editing and memory, a talking terminal has to provide a "say again" feature. Finally, consider, for a moment, how you would read this article aloud to someone. Would you read the punctuation as pauses, or would you say the names of the punctuation symbols? Would you pronounce acronyms, such as ASCII, or would you spell them out letter by letter? Would you read the string of digits 1234 as "one thousand, two hundred, and thirty-four," or "one, two, three, four," or use some other method? A talking terminal should be able to present the information in a variety of ways, suited to your needs and preferences.

Today's commercially available talking-terminal products (see table 1) represent two different design strategies. The speech-related features and capabilities have either been built into an existing conventional computer terminal, as with the Total Talk and the FSST-3, or are in a self-contained accessory module connected in series on the communication line between the computer and the terminal, as with the VERT. These two design



# Get Omni quality for as little as \$1.99...

# even if all you want is a 10 pack.

Call toll-free for great savings on Omni's complete line of 5¼" premium disks. Each is certified error-free at a minimum of twice the error threshold of your system. Each is rated for more than 12 million passes without disk-related errors or significant wear. And each is precision fabricated to exceed all ANSI specifications with such standard features as reinforced hub rings and Tyvec sleeves. Get same day shipment and an unconditional, no hassle money-back guarantee.

## ARCHIVE

152 Boston Turnpike  
Shrewsbury, MA 01545  
(800) 343-0314; In Mass:  
(617) 756-2960



Call toll free  
(800) 343-0314  
In Mass: (617) 756-2960

Call if you're not sure which disk is compatible with your system. Call for prices on 96 tpi and special formats. We offer an unconditional money-back warranty. We're here to help.

Be sure to indicate system name and model # at right.

# of 10 Packs	5¼" Disks	Price Per 10 Pack	Total Price
_____	Single side/single density	\$19.90	\$ _____
_____	Single side/double density	\$23.90	\$ _____
_____	Double side/double density	\$39.90	\$ _____
_____	Flip/Floppy reversible Double side/double density	\$39.90	\$ _____
_____	Protective plastic library case (in lieu of soft storage box)	\$ 2.99	\$ _____
	Shipping and handling		\$ 1.50
	5% sales tax (Mass. only)		\$ _____
	<b>Total</b>		\$ _____

Circle 33 on Inquiry card.

Check  
 COD

Master Card  
 VISA

Card # \_\_\_\_\_ Exp. \_\_\_\_\_

System and model # \_\_\_\_\_

Name \_\_\_\_\_

Address \_\_\_\_\_

Tel. \_\_\_\_\_

# IBM personal computer UCSD p-System™ IV.1

A superior implementation of the UCSD p-SYSTEM is available NOW for your IBM Personal Computer.

Network Consulting has added many features that the professional programmer will find useful. These features are not available from any other sources.

- Hard disk support for Corvus, Tall Grass Technology and others
- 25% more floppy storage, without adding or modifying hardware, retaining compatibility with standard IBM diskettes
- Double sided and double sided/double tracking stepping floppy disk drive support
- Up to 800K on each mini-diskette
- RAM disk support (a pseudo-floppy volume that uses up to 512k RAM)
- 8086/87/88 macro assembler
- Extended memory support
- Adaptable system support available for adding custom I/O drivers
- Remote Terminal support
- XON/XOFF flow control for serial printers
- A library of program modules and other utilities
- Disk write verification
- and more!

#### Standard p-System features include:

- Standard I/O redirection (including command files)
- Dynamic program overlays
- Support for asynchronous processes and concurrency primitives in Pascal
- Fast Pascal p-code compiler
- Fast FORTRAN and Basic p-Code compilers also available
- A powerful screen oriented editor
- A filter for handling both files and volumes
- A Native Code Generator that processes your Pascal, Fortran and Basic programs to convert parts of them to native machine code
- Dynamic runtime binding of separately compiled programs and units
- Turtlegraphics for easy graphics displays
- Print spooler for background printing
- Symbolic debugger

**UCSD p-SYSTEM from  
Network Consulting**  
The only serious choice for business  
™ The Regents of the University of California



**Network Consulting Inc.**  
A106 - 1093 W. Broadway  
Vancouver, B.C.  
Canada V6H 1E2  
(604) 738-3500

**Product:** VERT (Verbal Emulation in Real Time)  
Self-contained speech unit connected in RS-232C communication line between computer and any terminal.  
**Price:** \$5900 (with educational discount \$4990)  
**Manufacturer:** Automated Functions Inc.  
Suite 813  
4545 Connecticut Ave. NW  
Washington, DC 20008  
(202) 362-6292

**Product:** Total Talk (other models are available)  
Hewlett-Packard HP-2621 terminal with added speech circuitry.  
**Price:** \$4990  
**Manufacturer:** Maryland Computer Services Inc.  
2010 Rock Spring Rd.  
Forrest Hill, MD 21050  
(301) 838-8888

**Product:** FSST-3 (Free-Scan Speech Terminal)  
Zenith Z-19 terminal with added speech circuitry.  
**Price:** \$4495  
**Manufacturer:** Triformation Systems Inc.  
3132 Southeast Jay St.  
Stuart, FL 33494  
(305) 283-4817

Table 1: Manufacturers of talking terminals.

strategies have significant ramifications in two of the three areas of comparison: speech review and speech-parameter control.

### Translation Algorithms

An exhaustive comparison of the intelligibility and acceptability of the speech output—measures of listener comprehension and preference—requires rigorous performance measures. Such scientific evaluation is beyond my resources. Nevertheless, I can offer some useful observations on the different text-to-speech algorithms used in these talking terminals.

Though some manufacturers do not acknowledge the ancestry of the text-to-speech algorithms they use, it is reasonably safe to infer that both the VERT and Total Talk use the McIlroy (Bell Laboratories) algorithm, as enhanced by NIH (National Institutes of Health), and that the FSST-3 uses the NRL (Naval Research Laboratory) algorithm. The McIlroy enhanced algorithm uses about 1000 rules, and the NRL uses about 600 in performing the letter-to-phoneme or word-to-phoneme translation. (A phoneme is the smallest sound unit of speech. When we speak, we string phonemes together to produce words.)

Both algorithms are quite ade-

quate, with translation accuracy, linguistically speaking, of about 90 percent. In my experience, I find that the McIlroy algorithm handles difficult words correctly more often than the NRL. Neither of them makes any particularly egregious errors in the text-to-speech translation.

### Choosing Synthesizers

The only viable synthesizers to date are those that use phoneme synthesis, rather than synthesis by analysis (speech encoding), because the synthesizer must be able to speak an unrestricted vocabulary. The speech-encoding synthesizers, such as Texas Instruments' TMS5221 LPC (linear-predictive coding) synthesizer or National Semiconductor's Digtalker, are still limited to fixed, pre-recorded vocabularies. Both the VERT and the Total Talk use the Votrax VSB single-board speech synthesizer; while the FSST-3 uses the older Votrax VSA.

Both Votrax synthesizers are capable of independent variation in speech rate and pitch, under either manual or program control. The VERT takes advantage of the programmable-speech-rate control to enhance the pronunciation duration of very short and very long words, while also providing you with

**WESTICO** — The Software Express Service that really delivers:

# LANGUAGE PROCESSORS

When it comes to providing quality programs for serious microcomputer users — come to Westico. And you'll find more than quality software. You'll find instant response. In most cases, your order will be shipped within 24 hours. You'll also find the technical expertise on staff when you need help. For language processors and lots more, it's Westico. Here's just a sample of the more than 150 quality programs currently in stock:

**PL/I-80™** — Powerful application programming language for microcomputers. Implements on a micro the ANS Subset G language for minicomputers. Includes native code compiler, LINK-80 linkage editor, LIB-80 subroutine library manager, PLILIB run-time library and RMAC relocatable macro assembler. \$475/\$35. LINK-80 and RMAC also available separately.

**BT-80™** — Efficient B-tree key indexed access method for PL/I-80. Features key length to 63 bytes, unique or duplicate keys, and data records to 4096 bytes. Datasets can be spread over 8 files for a total of 64 megabytes. \$200/\$30.

**BASIC-80** — Extremely fast interpreter features double precision floating point math, 40 character variable names, CHAIN/COMMON, random and sequential files, EDIT, CALL with parameters and an overlay technique. \$350/—.

**BASIC COMPILER** — Compatible with BASIC-80. Produces extremely efficient, optimized 8080/Z80 machine code. Includes macro assembler, linkage editor and subroutine library manager. Compiled programs can be linked with FORTRAN-80, COBOL-80, and assembly language programs. \$395/—.

**CBASIC™** — BASIC language compiler/interpreter for development of financial and business application programs. System \$120/\$20.

**CBASIC-86** — Implementation of CBASIC for CP/M-86. INT files compatible with CBASIC and supports 128K main memory. Requires CP/M-86 or MP/M-86. \$325/\$30.

**CB-80™** — Native code 8080 compiler of CBASIC language. Offers all of the features of CBASIC plus the speed and versatility of a compiler. Includes linkage editor which can create overlay modules. Supports CP/M and MP/M II. \$500/\$30.

**FORTAN-80** — Includes full ANSI standard X3.9 except COMPLEX data type. \$500/—.

**LYNX™** — Friendly overlay linkage editor for creating COM files from Microsoft compatible REL files. Constructs programs that use all available memory including that used by LYNX itself. Program size can be increased at least 9K without using the overlay feature. The overlay option is vital to programs larger than available memory. Easy to use with BATCH and HELP commands. \$250/\$25.

**PASCAL/MT+™** — Compiler produces 8080/Z80 code. Standard REL file can be linked with other languages. Includes linker, debugger disassembler and special Speed Programming Package with editor and Pascal syntax checker. \$475/\$30.

**COBOL-80** — Complies with ANSI Level 1 requirements and most useful features of Level 2. SCREEN SECTION for definition of CRTs. \$750/—.

**XASMxx** — Family of microprocessor cross-assemblers. Designed to run on 8080/Z80 based microcomputers under a CP/M-like operating system. Support for Motorola 6800, 6801, 6803, 6805, 6809; RCA 1802; COP400; Intel 8048, 8051; MOS 6502. \$200/\$25.

**XLT86™** — Translates Intel 8080 assembly language source code into optimized Intel 8086 source code. \$150/\$10.

**The Westico 24-Hour Computer Hotline (203) 853-0816 (300 baud) for detailed information and quick access ordering.**



• Westico has more than 150 programs for professionals and businesses that use a wide variety of microcomputers including: TRS-80 Model II, Apple, Vector Graphic, Cromemco, North Star, Micropolis, Ohio Scientific, Altos, Dynabyte, IBM, Intertec, Xerox, Zenith, Northern Telecom, AVL Eagle and more. We're working hard to be your software company.

For **FREE** catalog  
circle reader service number. More  
than 150 quality programs in stock.

#### 4 Ways to order

- Write Westico, Inc., 25 Van Zant Street, Norwalk, CT 06855.
- Call (203) 853-6880.
- Telex 643-788
- Dial-up our 24-hour computer (300 baud) (203) 853-0816.

COD, MasterCard and VISA accepted.

Prices do not include shipping and are subject to change. In CT add 7½% sales tax. All sales final.

Manual price may be credited toward purchase of software.

Dealer inquiries invited.

WES-43

Copyright © 1982 Westico, Inc.

**WESTICO**  
The Software Express Service

25 Van Zant Street • Norwalk, Connecticut 06855  
(203) 853-6880 • Telex 643 788

Circle 486 on inquiry card.

manual speech-rate and pitch controls. The Total Talk and the FSST-3 offer you manual speech-rate and pitch controls.

The Votrax VSA and VSB synthesizers seem quite similar with respect to their phoneme production, but the FSST-3, which uses the VSA, definitely sounds inferior; whether this is an artifact of the VSA synthesizer or poor audio amplification, I don't know.

You may wonder why none of these products uses the new Votrax SC-01A integrated circuit, which is

less expensive. The single-quantity cost of the VSB is about \$800, while the SC-01A is \$70. But there are two major reasons why the SC-01A is not used. The speech-rate and pitch controls are both dependent on the same clock signal or timing circuit, affecting the ease with which intelligible speech may be produced. Also some people are concerned about the acceptability of the SC-01A's sound quality. Only scientific performance measures can determine which Votrax synthesizer is ultimately more intelligible. (For a description of an

application using the Votrax SC-01A speech-synthesizer chip see Steve Ciarcia's article on page 64 in this issue.)

### Speech-Review Capabilities

Imagine that a talking terminal is reading this article to you. Suddenly, you wonder at what you just heard—either a terrible pronunciation of a proper name (like "Ciarcia" perhaps) or maybe just a word that you don't recognize. You would like to stop the speech, perform some review functions to repeat the last few lines or words, or spell the word in question, and then continue the speech just where you stopped it.

Stopping the speech output of a talking terminal requires that the stream of characters coming from the host computer to the terminal be halted. (Some remote computers make this very difficult.) Only the VERT attempts (when the feature is enabled) to tell the host computer not to send any more text when reviewing. The Total Talk loses data after receiving 120 characters of yet-untranslated text from the host computer. The FSST-3 loses data after accumulating 1920 characters of yet-untranslated text.

All three products allow you to review the text saved in memory. The VERT saves the most recent 12,000 characters, the Total Talk saves two screens (48 lines of 80 characters each) in the HP-2621's display memory, and FSST-3 saves from one to three screens (depending upon the amount of memory installed) in the Zenith Z-19's display memory. All three products can repeat the text in its entirety or by character, word, or line. In addition, the VERT can repeat text by phrase, sentence, or paragraph.

The Total Talk and the FSST-3 perform their review functions as a result of using the standard cursor-movement and screen-print functions of the HP-2621 and Z-19 terminals. The VERT responds with its review function to an ASCII (American Standard Code for Information Interchange) escape-code sequence from any data-terminal equipment.

## WHAT A BEAUTIFUL COMPUTER!



That's the reaction we get from BRIDGE computer system customers.

### The BRIDGE Formula for SPEED 256k + MEMDSK + Cache BIOS = BRIDGE SPEED

Let's decipher the formula . . .

Take MEMDSK and Cache BIOS, two major operating system enhancements, add 256k and perform ordinary CP/M disk operations at 4 to 20 times the normal speed on an InterSystems computer.

What does this mean? If you are a software developer, you'll know for sure. Imagine the possibility of executing your compiler work out of memory. How? The components of BRIDGE SPEED allow your files to reside in memory after your first run so that with your second run you move from one area of memory to another, rather than from disk to memory.

Imagine this . . .

- cutting disk access time by 10
- producing twice as much code per month
- minimizing disk wear

Your imagining becomes reality by using BRIDGE'S SPEED formula.

Hardware consists of:

- 6 MHz Z80 CPU with memory management system
- 256k RAM memory (expandable to 1 Mbyte)
- Disk drive options: two 8" (2.4M) or 5.25" (0.8M) disks, or 8" or 5" hard disk

Run your stream of needs in the fast lane. "BRIDGE" the gap to a high performance Enhanced Computer System. For complete information and prices, call us at (617) 244-8190 or circle the reply number. Dealer inquiries invited.

 **BRIDGE**  
Computer Company  
DIVISION OF SEA DATA CORPORATION  
ONE BRIDGE STREET  
NEWTON, MASS. 02158 U.S.A.  
PHONE: (617) 244-3203

MEM-DISK, BMATE and AUTO-CHECK are trademarks of BRIDGE Computer Company, Division of Sea Data Corporation



QUASAR

REPORT (APR. 1982)



	FEBRUARY	JANUARY	DIFF. %
BEER	50,842	51,240	-0.8
WHISKY	28,653	30,223	-7.1
WINE	85,000	80,251	5.2
OTHERS	14,848	14,330	2.4
TOTAL	147,638	147,444	-0.1

## One picture is worth a thousand numbers.

Introducing the new wide-tape Quasar® 4-Color Plotter, driven by the portable with the speed and power of a desktop computer.

Coupled with the sophisticated Quasar Hand-Held Computer, this advanced, 80-character plotter turns dry statistics into dramatic graphics anytime, anywhere. Makes analysis easier, presentations more exciting.

The Quasar HHC is actually a desktop computer you can take with you. Its heart is a fast, powerful 6502 microprocessor, with powerful programming languages—Microsoft BASIC, SnapBASIC and SnapFORTH, and high-memory capacity of up to 8KB RAM and 16KB ROM internal, expandable with external Memory Modules and ROM's or EPROM's in capsules. Operates on rechargeable NiCad batteries and retains data with power off.



The Quasar mainframe has a complete range of intelligent peripherals including a new 40-Character Printer, Telephone Modem/Cassette Interface, RS232 Interface, Color TV Adaptor, I/O Adaptor that works with up to 6 peripherals.

That means the Quasar HHC system can be your personal computer and database, or portable terminal that interacts with a large, central computer, or supplementary system to host computers for data retrieval, collection and transfer.

An expanding array of snap-in software includes modelling programs for "what if" alternatives, programs for time-billing professionals, financial calculations, and many others for scientific, engineering, marketing and business applications.

For a complete information kit, write Quasar HHC Dept., or use Reader Service Card.

# Quasar

Portable Computer Systems

### For HHC system tailored to your specific application contact System House/OEM:

American Medical Instruments Albany, CA 415-525-1113	Cyber Diagnostic Corp. Aurora, CO 303-695-8751	Impact Technologies Group, Inc. Salisbury, NC 704-637-6183	Systems 7, Inc. Houston, TX 713-468-4394
Insta-Data Systems, Inc. Simi Valley, CA 805-522-9629	Pentagon Industries, Inc. Chicago, IL 312-867-9200	System Exposure Dunedin, FL 813-736-5154	Agent Computer Services, Inc. Columbia City, IN 219-422-6552

### Quasar HHC Distributors:

RPC Electronics Pittsburgh, PA 412-782-3770	InterNet San Francisco, CA 415-227-4258
Straitline Marketing Inc. New York, NY 212-445-4225	

**NOW!**  
Safety and  
Peace of Mind  
with

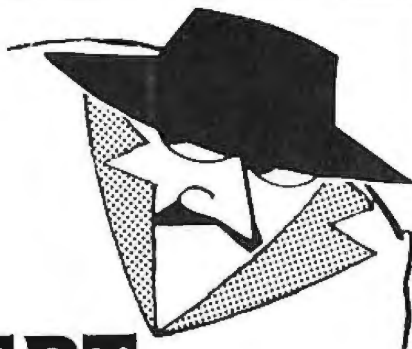

# DOOR-ALERT

Just \$19.50

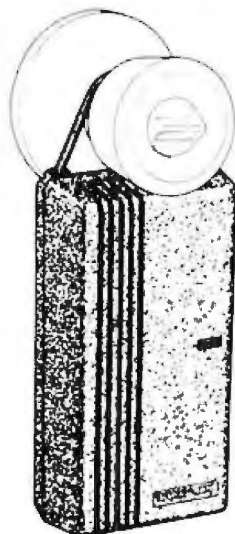

Keep the thieves and rapists out of your home! Protect yourself and your loved ones with DOOR-ALERT. Simply slip DOOR-ALERT over the inside door knob. If anyone touches the door with his hand, with a key, or with a tool, DOOR-ALERT will let out a piercing alarm and send the intruder on his way. And then it turns off automatically so that it won't keep alarming the neighbors.

DOOR-ALERT has a 3-second built-in delay.

This has two purposes:

1. So the alarm won't sound if someone just casually touches the door, and

2. To give you time to deactivate the alarm.

Keep DOOR-ALERT on the inside of your front door both while you are at home and while you are away. Nobody will be able to enter your home. And, of course, it is something you should have with you on your travels. DOOR-ALERT is beautifully styled. It measures 4½ x 2 x 1 and takes up almost no room. It works on one 9-volt cell (not included). It costs just \$19.50. (you get two for \$34.50) plus \$2.00 postage and handling — a great investment for PEACE OF MIND.

**GUARANTEE:** Satisfaction is completely guaranteed! Use DOOR-ALERT for 15 days. Not pleased? You owe nothing — not even an explanation. Just return for complete, prompt refund. You have everything to gain, and nothing to lose. In fact you'll wonder how you ever got along without DOOR-ALERT.

Yes! DOOR-ALERT is for me. Please send me \_\_\_\_\_ units at only \$19.50 each, plus \$2.00 postage and handling (California residents please add 6% sales tax). Total \$ \_\_\_\_\_ enclosed.

NAME \_\_\_\_\_

ADDRESS \_\_\_\_\_

CITY \_\_\_\_\_ STATE \_\_\_\_\_ ZIP \_\_\_\_\_

SEND TO: DOOR-ALERT

6333 Woodman Avenue  
Van Nuys, CA 91401

The integration of speech capability with an existing, popular terminal design—the case for both the Total Talk and the FSST-3—has positive and negative consequences. Such integration negates the need to acquire a computer terminal separately when you shop for a talking terminal. On the other hand, building the speech circuitry into terminals has resulted in a performance characteristic especially annoying to programmers: both the FSST-3 and the Total Talk (Z-19 and HP-2621 terminals, respectively) never speak cursor, character-attribute, or print-function codes.

Anyone who buys a VERT must also acquire a standard computer terminal. This terminal is connected to one of the VERT's two ports, while the computer (or modem) is connected to the other. The VERT transmits all characters received from the host computer to the terminal, while translating and speaking if appropriate. The VERT can also transmit all characters received from the terminal to the host computer, though usually some are trapped as the VERT function codes. This black-box filter-like approach to the problem of providing a talking terminal is modular and well formed.

## Speech Parameter Control

A talking terminal should give you the option of setting speech-control parameters. It should either decide the most appropriate way to translate and speak segments of text where machine-based decisions are competent or provide you with the capability of manually setting those decision parameters which cannot be successfully handled by a machine. A program can decide whether to pronounce or spell IBM, NIH, or ASCII.

The VERT uses truth tables for prefixed and suffixed letter pairs to determine whether to spell or pronounce alphabetic tokens. It is rather more difficult for a program to decide whether to say 370 as "three seven zero," "three hundred seventy," or "three seventy." If the text is referring to an IBM 370 mainframe computer, the choice will be obvious to you. But

# Now! A 60 MHz Tektronix scope built for your bench.

**Wide-range vertical sensitivity:** Scale factors from 100 V/div (10X probe) to 2 mV/div (1X probe). Accurate to  $\pm 3\%$ . Ac or dc coupling.

**Two high-sensitivity channels:** dc to 60 MHz bandwidth from 10 V/div to 20 mV/div; extended sensitivity of 2 mV/div at  $> 50$  MHz.

**Sweep speeds:** from 0.5 s to 50 ns. To 5 ns/div with X10 magnification.

**Delayed sweep measurements:** Accurate to  $\pm 3\%$  with single time-base 2213; to  $\pm 1.5\%$  with dual time-base 2215.

**Complete trigger system.** Includes TV field, normal, vertical mode, and automatic; internal, external and line sources; variable holdoff.

**Probes included.** High-performance, positive attachment 10-14 pF and 60 MHz at the probe tip.

In 30 years of Tektronix oscilloscope leadership, no other scopes have recorded the immediate popular appeal of the Tek 2200 Series. The Tek 2213 and 2215 are unapproached for the performance and reliability they offer at a surprisingly affordable price.

There's no compromise with Tektronix quality: The low cost is the result of a new design concept that cut mechanical parts by 65%. Cut cabling by 90%. Virtually eliminated board electrical connectors. And obviated the usual cooling fan.

Yet performance is written all over the front panels. There's the bandwidth for digital and analog circuits. The sensitivity for low signal measurements. The sweep speeds for fast logic families. And delayed sweep for fast, accurate timing measurements.

**The cost: \$1100 for the 2213\*, \$1400 for the dual time base 2215.** You can order, or obtain more information, through the Tektronix National Marketing Center, where technical personnel can answer your questions and expedite delivery. Your direct order includes

probes, operating manuals, 15-day return policy and full Tektronix warranty.

For a demonstration stop by your local Tektronix Sales Office.

**ORDER TOLL FREE  
1-800-426-2200**

**Ask for Department J0333**  
In the state of Washington,  
Call (206) 253-5353 collect.

\*Price FO B Beaverton OR

# CP/M DATA ENTRY

## "RADAR"

RADAR is a high speed data entry system that will run on any CP/M system providing a "3741" style key-to-disk environment. RADAR is ideal for replacing KEYPUNCH machines and older, slower key-to-disk systems like the 3741's and 42's.

### Features:

- Verify Mode
- Check Digit Processor
- Auto Dup/Manual Dup
- 16 Accumulators
- Parameter Driven (No Programming)
- "Virtual" File Access
- Add or Delete Records
- Record Retrieval By Number Or Content
- Full Editing Capability
- Operator Prompts
- Extremely Fast (Written In Assembly Language)

In addition to "heavy-duty" data entry, RADAR is also the ideal "front-end" for many applications programs, providing aquisition and retrieval of keyed data with a degree of reliability simply not possible with any other technique. RADAR can cut programming time by more than 30%, simply because there is no longer any need to write the "input" portion of a program, just let RADAR handle it!

Write or call for free brochure. The RADAR manual is also available separately for \$25.00.



**SOUTHERN  
COMPUTER  
SYSTEMS,  
Inc.**

P.O. Box 3373A  
Birmingham, AL 35255  
Phone: 205-933-1659

### Text-to-Speech Translation

Several independent efforts have resulted in various grapheme-to-phoneme translation systems for speech synthesis. Graphemes are letters or other characters, and phonemes are the sounds of speech. There are two approaches to the problem of translating written language (orthography) to its spoken (phonetic) form. All current efforts to create artificial speech use either one or both of these approaches.

The first approach searches a dictionary of words and/or word fragments (morphemes) for corresponding phonetic representations. Such dictionaries that are expected to satisfy a wide variety of contexts must be quite large. The software responsible for searching a dictionary must be able to account for various forms of a given entry. When dictionaries of morphemes are used, the software must be capable of separating the words to be translated into their constituent morphemes.

The second approach uses grapheme-to-phoneme translation rules. Such rules attempt to describe a correspondence between the orthographic and phonetic forms of the language. Some efforts have resulted in a combination of these two methods of translation, resorting to the second when the first fails to satisfy a translation request.

### Unrestricted Text

In order to remove all restrictions on the content of the text being translated, the translation system must be able to distinguish among English words, acronyms, mnemonics, abbreviations, etc. The input stream of text to be translated is parsed into tokens that contain characters of the same type.

Tokens may be divided into types alphabetic, punctuation, numeric, or symbolic. A token is complete when a character in the input stream of another token type is encountered. The type of a token determines the classification of rules used in translating the token. The selection of the rule set is dependent on the token type. There are currently rule sets for English, numerals, punctuation, and

spelling. Spelling is the English pronunciation of a single character's name. You must also consider that alphabetic characters do not always represent an English word.

Frequency tables representing the occurrence of letter pairs (digrams) or triplets (trigrams) offer significant help in deciding whether a group of characters represents an English word, an acronym, or a mnemonic. The frequency tables currently in use were derived from a lexicon of about a quarter of a million words. The digram-frequency table is reduced to a binary table that represents the occurrence or nonoccurrence of letter pairs in the lexicon. The use of digram or trigram tables could be expanded to the detection of specific subsets of English vocabulary. One case where this is useful: frequency tables derived from a common-usage dictionary and a lexicon of medical terms are significantly different.

### Rule-Directed Translation

Orthographic representations of text are translated to phonetic representations by means of a production system. The rules used in the English-to-phoneme translation match context-sensitive patterns to the word or word token. The rules are of the form:

left-context [current-token]  
right-context = phonemes

The current-token is the character(s) that is currently being translated by a rule. The left-context and the right-context are the text in which the current-token must be matched. These left- and right-contexts may contain special symbols that define arbitrary patterns of characters. The current-token may not contain these special symbols and must match, character for character, the token of the word being translated. The right-hand part of a rule gives the phonetic symbols representing the current-token. English phoneme rules are classified in subgroups of alphabetic, numeric, punctuation, and spelling rules. The phonetic replacements selected by the successful matching of rules are used to drive a speech-synthesizing device.



a translation program has no way of "knowing" the correct pronunciation of a number or word on the basis of the context in which it was used. The Total Talk and the FSST-3 simply speak numbers digit by digit. The VERT does the same or says numbers as whole words depending on your parameter setting.

Ironically, it's often desirable to make your talking terminal remain silent, while continuing to display and save text. The reasons are many, varied, and a matter of preference, but the capability is important. Total Talk will remain silent when you depress its Silence key. The VERT can be made to remain silent until a new line, speech command, or predefined text pattern is received. The FSST-3 can start or stop speaking on command.

No matter what the accuracy and proficiency of a text-to-speech translation system, there will always be words or symbols that you would like

to have spoken your own way. For example, it is becoming popular in academic computer-science circles to use the word "bang" or "shriek" for the exclamation-point character (!). I am sticking with the conservative "exclamation," even though the newcomers are shorter and can be spoken more quickly. The VERT offers you the power to define, in English, your own translation preferences. You simply define a rule that says ! = "bang," or whatever.

### On the Horizon

We may see the cost of talking terminals either decrease as new speech synthesizers are used, or increase as speech capabilities are integrated with personal computers. Whatever the result, the cost of a talking terminal will remain a serious problem for visually disabled persons. Talking-terminal manufacturers should expand the market for their pro-

ducts—not limit it to the visually disabled. Increased sales will lower costs and benefit everyone in the long run.

One perplexing problem remains. The rapid advance of video-display technology has promoted the ever-increasing use of video-dependent software. Users of talking terminals will require programmed solutions for describing essentially visual information. Unfortunately, information science is still far from providing accurate verbal descriptions of two-dimensional space, thus, for instance, making it impractical to run a screen-oriented program like Wordstar solely from spoken output.

Though the sound quality of available phoneme synthesizers is definitely far from human-sounding, I've found that visually impaired persons find it intelligible and acceptable with use. I believe that computers with natural-sounding speech and more sophisticated algorithms for translation will be achieved in this decade. ■

## WHAT'S ECC?

ECC (Error Correction Code) is a polynomial derivative which is used to detect and correct errors. In simpler terms, this means that the computer will detect and automatically correct data errors sometimes generated spuriously in the equipment.

VR Data's HARD DISK III has this feature. If your system will abend or die during a data error or if you must always have the correct data for your functions, ECC is a

necessity. This feature has filtered down from the larger computer systems and is now used by manufacturers of superior micro computer products.

**Imagine a 5 meg Winchester Hard Disk with the following features:**



**ALL FOR \$1899. Complete**

- ECC—onboard buffer
- FCC approval—Heavy Duty Power Supply
- Automatic power on with system
- Heavy duty linear power supply
- Gold plated contact on all connectors
- Heavy gauge aluminum chassis
- 115/230 VAC 60/50 HZ Standard
- State-of-the-art controller
- 2 pass forced air cooling system

Interfaces to: Radio Shack TRS 80 Model I • Radio Shack TRS 80 Model III • IBM Personal Computer • Others to be announced

**ONLY FROM VRdata**

**777 Henderson Boulevard N-6 Folcroft, PA 19032  
(215) 461-5300 (800) 345-8102**



**400**  
 16K ... \$249  
 32K ... \$389  
 48K ... \$489

**800**  
 16K ... \$649  
 32K ... \$724  
 48K ... \$769

410 Recorder .....	\$76.00
810 Disc Drive .....	\$449.00
822 Printer .....	\$269.00
825 Printer .....	\$589.00
830 Modem .....	\$159.00
820 Printer .....	\$259.00
850 Interface .....	\$169.00
CX40 Joy Stick .....	\$18.00
CX853 16K RAM .....	\$77.95

Microtek 16K RAM .....	\$74.95
Microtek 32K RAM .....	\$119.95
Remdisk (128K) .....	\$429.95
Intec 48K Board .....	\$219.95
Intec 32K .....	\$119.95
One year extended warranty .....	\$70.00
481 Entertainer .....	\$69.00
482 Educator .....	\$130.00
483 Programmer .....	\$49.00
484 Communicator .....	\$344.00

# FRANKLIN ACE 1000



64K Personal Computer Hardware, software and peripheral compatible with the Apple II and even has some features not found on the Apple.  
**Call now for best price!!**

## HOT ATARI GAMES

PAC-MAN .....	\$35.00
Centipede .....	\$35.00
Caverns of Mars .....	\$32.00
Asteroids .....	\$29.00
Missile Command .....	\$29.00
Star Raiders .....	\$39.00
Canyon Climber .....	\$25.00
Protector .....	\$24.00
Mouskattack .....	\$31.00
Jawbreaker .....	\$27.00
Ghost Hunter .....	\$24.00

## K-BYTE ROM CARTRIDGE GAMES FOR YOUR ATARI

Krazy Shoot Out .....	\$39.00
K-razy Kritters .....	\$39.00
K-razy Antics .....	\$39.00
K-star Patrol .....	\$39.00

**STICK STAND**  
 \$6.99

ARCADE ACTION FROM YOUR ATARI JOYSTICK



## PERCOM

Finally, a dual disk drive for the Atari 800/400. Both single and dual drive models read both sides of the disk! Will read all disks written for Atari 810. CALL FOR INTRODUCTORY PRICE!



## Telecommunications Modems

Hayes Smart .....	\$239.00
Chronograph .....	\$199.00
Micromodem II .....	\$279.00
Micromodem 100 .....	\$309.00
Novation Auto .....	\$239.00
D Cat .....	\$169.00
Cat .....	\$159.00
Anchor Modem .....	\$79.00

## AMDEK MONITORS

300G .....	\$169.00
Color I .....	\$339.00
Color II .....	\$699.00
Color III .....	\$429.00

### OTHERS

Zenith 9" (Green) .....	\$119.00
BMC 12" Green .....	\$85.00

## NEC COMPUTERS

8001-A .....	\$749.00
8031 .....	\$749.00
8012 .....	\$549.00

### PRINTERS

8023 .....	\$549.00
7710/7730 .....	\$2399.00
3510/3530 .....	\$1789.00

### MONITORS

JB-1201 .....	\$179.00
JC-1201 .....	\$349.00
JC-1202 .....	\$899.00

## VISICORP

VISICALC Apple II+ .....	\$189.00
Atari .....	\$189.00
Commodore .....	\$189.00
IBM .....	\$189.00

Also available are:

VISIDEX	VISIPILOT
VISIFILE	VISITERM
VISIPACK	VISITREND

## SOFTWARE CATALOG

We stock manufacturer's and third party software for most all computers on the market! Call today for a copy of our new

You'll find programs by Atari, APX, Data Soft Crystal Software, EPYX, Synapse, OnLine, Arcade Plus, K-BYTE, Magis, Canadian Micro Professional Software, Creative Software, BPI, VISICORP, Commodore, NEC and of course our own!

## Maxell Disks

MD I (box of 10) .....	\$36.00
MD II (box of 10) .....	\$46.00
MFD I (8") .....	\$44.00
MFD II (8" Double Density) .....	\$54.00
Syncom (box of 10) .....	\$29.00

## Computer Covers

Atari 400 .....	\$6.99	Commodore VIC-20 .....	\$6.99
Atari 800 .....	\$6.99	Commodore 8032 .....	\$14.99
Atari 810 .....	\$6.99	Commodore 8050/4040 .....	\$10.99

# west 800-648-3311

In Nevada CALL (702)588-5654

P.O. Box 6689 Stalene, NV. 89449

**hp HEWLETT  
PACKARD**



**HP-85 \$1969**

HP-87 .....	\$1799.00
HP-125 .....	\$1999.00
HP-85 16K Memory Module .....	\$169.00
5 1/4" Dual Master Disc Drive .....	\$1799.00
Hard Disk w/ Floppy .....	\$4349.00
Hard Disk .....	\$3549.00
"Sweet Lips" Plotter .....	\$1199.00
80 Column Printer .....	\$649.00



**CBM 8032  
\$999**



**Commodore  
Business Machines**

Word Pro 5+ .....	\$319.00
Word Pro 4+ .....	\$299.00
Word Pro 3+ .....	\$199.00
The Administrator .....	\$379.00
InfoPro Plus .....	\$219.00
Power .....	\$79.00

CBM 64 .....	CALL
4032 .....	\$669.00
8086 Upgrade Kit .....	\$369.00
Super Pet .....	\$1599.00
2031 .....	\$529.00
8250 Doubled Sided Disk Drive .....	\$1699.00
D9060 5 Megabyte Hard Disk .....	\$2389.00
D9090 7.5 Megabyte Hard Disk .....	\$2699.00
8050 .....	\$1299.00
4040 .....	\$969.00
8300 (Letter Quality) .....	\$1799.00
8023 .....	\$769.00
4022 .....	\$499.00
Pet to IEEE Cable .....	\$37.00
IEEE to IEEE Cable .....	\$46.00
Tractor Feed for 8300 .....	\$240.00

**hp HEWLETT  
PACKARD**

**HP 41CV  
CALCULATOR  
\$239**



HP 41C .....	\$189.00
HP 11C .....	\$79.00
HP 12C .....	\$114.00
NEW 15C .....	\$119.00
NEW 16C .....	\$125.00

HPIL PERIPHERALS IN STOCK!

**Televideo  
Terminals**

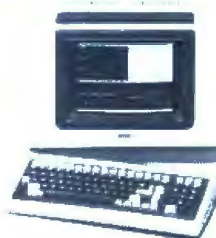

910 .....	\$579
912C .....	\$699
920C .....	\$749
925C .....	\$749
960 .....	\$939

802 .....	\$Call
802H .....	\$Call
816 .....	\$Call
806 .....	\$Call

**VIC 20**



**\$239**

VIC 1530 Commodore Datasette .....	\$69.00
VIC 1540 Disk Drive .....	\$499.00
VIC 1515 VIC Graphic Printer .....	\$339.00
VIC 1210 3K Memory Expander .....	\$32.00
VIC 110 8K Memory Expander .....	\$53.00
16K VIC Expansion .....	\$94.00
VIC 1011 RS232C Terminal Interface .....	\$43.00
VIC 112 VIC IEEE-488 Interface .....	\$86.00
VIC 1211 VIC 20 Super Expander .....	\$53.00
VIC Mother Board .....	\$99.00

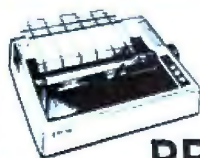

**EPSON  
PRINTERS**

MX 80 w/GraTrax .....	\$449
MX 80 FT III .....	CALL
MX 100 .....	CALL
ADA 1600 Parallel Printer to CBM .....	\$119.00
ATC-1 Parallel Printer to Atari .....	\$29.00
AP-80 Apple Parallel Card & Cable .....	\$69.00
IBM-1 Parallel Printer to IBM .....	\$32.00



**CITOH**

**PRINTERS**

Starwriter .....	
F10-40CPS .....	\$1439.00
F10-55CPS .....	CALL
Prowriter .....	\$499.00

ADA 1450 Serial Printer to CBM .....	\$139.00
ATC-2 Serial Printer to Atari .....	\$29.00
AP-S10 Apple Serial Card & Cable .....	\$95.00

**Smith-Corona**

**TP-1**

**\$649**



**Letter Quality  
Daisy Wheel  
12 CPS Text Printer**

In-stock items shipped same day you call. No risk, no deposit on C.O.D. orders. Pre-paid orders receive free shipping within the continental United States with no waiting period for certified checks or money orders. All prices shown are cash prices. Add 3% for Mastercard and Visa. NV and PA residents add sales tax. All items subject to availability and price change.

**CENTRONICS  
PRINTERS**

739-1 .....	\$519
739-3 .....	\$619
2 Meter RS232-RS232 Cables .....	\$29.95

— ALSO —

Diablo 630 Special .....	\$1799.00
Talley 8024-L .....	\$1629.00
IDS Prism .....	CALL

**OKIDATA  
PRINTERS**

82A .....	\$469.00
83A .....	\$729.00
84 .....	\$1099.00

NOTE

All of the above OKIDATA Printers come equipped with both parallel ports & RS232 Serial ports.

**800-233-8950 east**

477 E.  
THIRD ST.  
Williamsport  
PA 17701

IN PA  
CALL  
(717)327.9575

computer mail order east

# PRESENTING: THE NO-NONSENSE BOARDS.

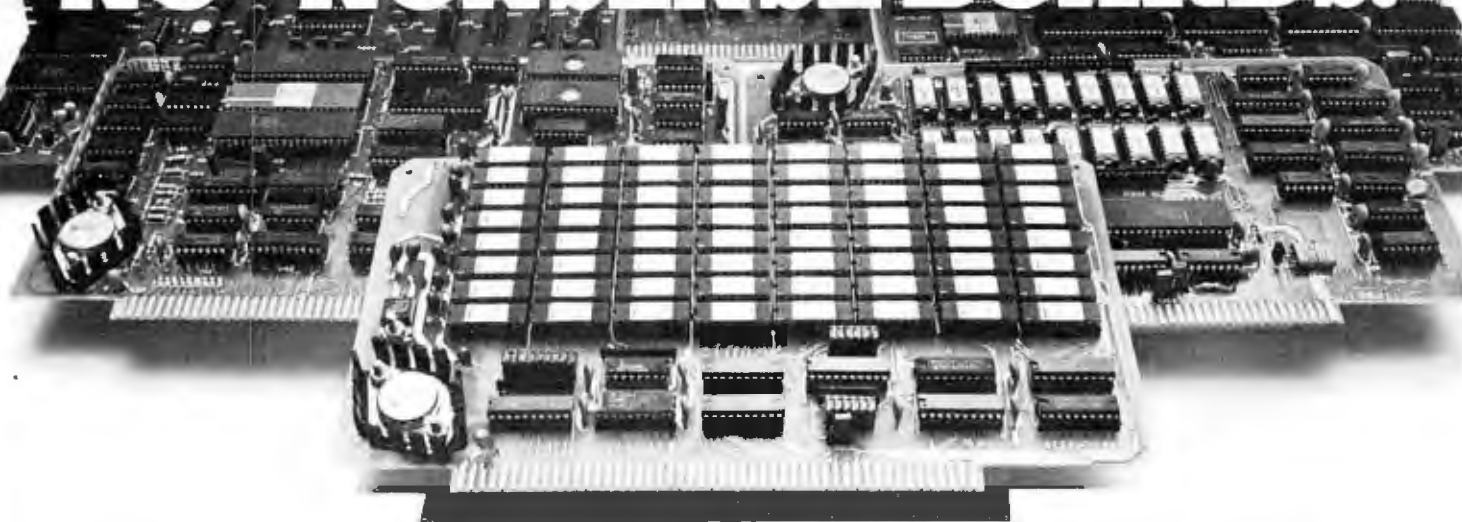

## The RAM67

Our RAM67 static RAM offers low power for cool operation and high reliability. It is the first S100 memory of its size to offer battery back up. The RAM67 will run without wait-states with any present S100 bus CPU.

### Advanced static RAM67 features:

- Low power CMOS RAM
- 100 ns access time
- No wait states with our 10 MHz *Lightning One*<sup>™</sup>
- 8/16 bit operation
- Phantom disable
- Battery back up option

If you need high performance and high reliability at an affordable price, the RAM67 is the memory for you.

128K RAM .....\$1495.00  
 Battery back-up option .....\$100.00

## The Lightning One

The *Lightning One* is the fastest S100 CPU board presently available. The 8086 processor with its two co-processors, the 8087 and 8089, provide exceptional data manipulation, numeric processing and I/O handling capability.

### The Lightning One features:

- 8086 or 8088 16 bit processor
- 4,5,8, or 10 MHz jumper selectable operation
- Optional 8087 and 8089 co-processors
- Onboard monitor with diagnostics
- 9 vectored interrupts expandable to 65

When you need mini-computer performance at micro-computer prices, the *Lightning One* should be your choice. Benchmarks available. Prices start at .....\$395.00

## Other LDP Products

In addition to the RAM67 and *Lightning One*, Lomas Data Products offers the following fine products:

**HAZITALL System Support**  
 2 serial ports, 2 parallel ports, clock/calendar, 9511 or 9512 math support (option), hard disk controller host interface ..... A & T, \$325.00

**LDP72 Floppy Disk Controller**  
 Single or double density operation, single or double sided disks, controls both 8" and 5 1/4" floppy drives, digital data separator for adjustment free reliable operation ..... A & T, \$274.95

**LDP128/256K Dynamic RAM**  
 An advanced dynamic RAM with static like performance. An ideal choice for large memory configurations where cost is an important consideration. No DMA, or reset restrictions ..... A & T, 128K \$795.00, 256K \$1395.00

**LDP88 8088 CPU Board**  
 Ideal for inexpensive systems requiring the processing power of a 16 bit instruction set. The LDP88 has up to 8K of on-board EPROM, 1K bytes of RAM, 1 serial RS232 port, 9 vectored interrupts, 5 MHz operation. Useable as a single board 8088 processor ..... A & T, \$349.95

## Software Available

**CP/M-86\***  
 Full track buffered BIOS, memory disk support, double density format ..... \$300.00

**MP/M-86\***  
 Full MP/M-86 implementation, hard disk and floppy disk support, plus memory drive. 1, 2 and 5 user configurations.

**MS-DOS\*\***  
 The IBM Personal Computer operating system, includes macro assembler ..... \$250.00

**Other software:**  
 BASIC86, BASCOM86, FORTRAN86, C, FORTH.



For 16 bit computing on the S100 bus, come to the leader...

# LDP

LOMAS DATA PRODUCTS, INC.

729 Farm Road, Marlboro, Massachusetts 01752 ☐ Telephone: 617-481-2822

\*CP/M-86 & MP/M-86 trademark of Digital Research.  
 \*\*MS-DOS trademark of Microsoft.  
 Lightning One trademark of Lomas Data Products, Inc.  
 Dealer and O.E.M. inquiries invited.

## The Cognivox VIO-1003

### Voice recognition and output for the Apple II

---

Dr. William Murray  
Computer Science Department  
Broome Community College  
Binghamton, NY 13902

---

The Cognivox VIO-1003, manufactured by Voicetek of Goleta, California, is a speech-recognition and voice-output peripheral for the Apple II computer. It is difficult to believe that for a modest \$295 for hardware and software, you can actually carry on a conversation with your computer.

The Cognivox can be "trained" to recognize a set of up to 32 words or short phrases (e.g., one, two, alpha, syntax error, etc.) This allows you maximum flexibility because the Cognivox can be trained with a game, business, or scientific vocabulary. As a matter of fact, you can save several sets of vocabularies on a disk. During a training session you enter the vocabulary into the computer by repeating each entry three times into the Cognivox microphone and typing the entry once. This trains the machine to recognize your voice. Voicetek cautions that other people's pronunciations of the same words may or may not be recognized.

The Cognivox, working within the frequency range of 100 to 3200 Hz (hertz), compresses essential speech information for one entry into a 48-bit pattern. This pattern is saved during the training session and will be used as a "mask," or model, for future comparisons. The system uses only 4K bytes of storage for the program and tables, and Voicetek claims up to a 98-percent word-recognition rate.

The voice-output vocabulary is entered in much the same way as the speech-recognition vocabulary. During a training session your words are digitized and stored in memory for future use. If you want your program to have voice output, the word or phrase is assembled and "spoken" through the built-in amplifier and speaker. The voice output sounds just like you, the trainer. Because the

speech-recognition and voice-output vocabularies are independent of each other, a wide range of responses is possible.

It should be noted here that the Cognivox is not a speech synthesizer; it is a speech digitizer. The voice output is strictly limited to the words or phrases that you enter. However, because you can use multiple vocabularies, this is not a serious limiting factor.

Steve Ciarcia's article "Use Voiceprints to Analyze Speech" (March

1982 BYTE, page 50) covers the techniques used to record voice prints. Steve points out that the quality of the speech-recognition system depends on what he calls the "templates" of the spoken words. The template or mask quality in turn depends on how much storage is available. His device, which produces voice patterns on an oscilloscope, uses bandpass filters starting at 31 Hz and covers an 8-octave range up to 4000 Hz. The results presented in the article show that most speech falls between 1000 and 4000 Hz, which is just about the range of the Cognivox.



Photo 1: The Cognivox VIO-1003 Voice Recognition and Voice Output System.

## At a Glance

### Name

The Cognivox VIO-1003

### Manufacturer

Voicetek  
POB 388  
Goleta, CA 93116  
(805) 685-1854

### Price

\$295

### Hardware

Includes the Cognivox VIO-1003 (housed in a 5- by 6- by 1 1/4-inch plastic case), microphone, and power supply; frequency response 100 to 3200 Hz; audio output 150 mW; power consumption 150 mW during recognition and 450 mW maximum during voice output; power supply 9 V DC, 300 mA (unregulated, wall-transformer type); microphone jacks provided on front panel, remote amplifier jack provided on back panel

### Software

The control program VOX4 and demonstration programs VDUMP, VTRAP, VOTH, and TONES, all on a 5 1/4-inch floppy disk

### Capabilities

Recognizes isolated speech; digitizes up to 32 words or short phrases per vocabulary set; allows separate recognition and speech vocabularies; accepts words or phrases up to three seconds each in spoken length; typical recognition accuracy of 98 percent for the voice it is trained to accept

### Hardware Required

Apple II with 32K or 48K bytes of memory, one disk drive, and DOS 3.3

### Documentation

26-page manual

### Warranty

120 days repair or replacement

### Audience

Those seeking to communicate by voice with their computers; potential uses include security functions, helping the disabled, and audio games

The Cognivox VIO-1003 comes completely assembled in an attractive 5- by 6- by 1 1/4-inch plastic case. The device plugs into the game-paddle I/O (input/output) port of the Apple and operates from a 9-volt power supply provided with the device.

The Cognivox contains an internal amplifier and speaker but also has an audio output jack for use with a higher-quality amplifier system. Voicetek provides a 120-day repair-or-replacement warranty on the Cognivox. Perhaps the best part of the system is the disk included in the package; it has several programs that allow you to save and restore vocabularies and play games. The Cognivox system requires the Apple II, 48K bytes of memory, and DOS 3.3 (16 sector).

## Getting Started

If you're like me, the first 10 minutes after the delivery of a computer peripheral can be very dangerous—you're extremely tempted to experiment with the hardware first and study the instructions later. But with the Cognivox you've just got to take time to read the first few pages of the 26-page *Cognivox User Manual*. All installation steps are explained in detail, but here is a summary of what gets your computer up and listening:

- First, plug the power supply into both the Cognivox and the wall outlet.
- With the computer off, plug the Cognivox into the game I/O port of the Apple.
- Next, plug the microphone into the Cognivox and set the volume control.
- Now boot the Apple using the program disk provided with the system.
- Type "RUN PROG4" and away you go.

When the system is booted you are provided with a menu of the disk selections. In addition to the main program (PROG4) Voicetek also includes four demonstration programs (I'll explain more about these later).

PROG4 is a demonstration program that immediately allows you to digitize your voice for voice output or speech recognition. You can also save or recall stored vocabulary from the disk. Let's imagine that you want to record a speech-recognition vocabulary. The program will prompt you with the question "How many words are in this vocabulary?" You may enter up to 32 words. Digitized words must be greater than 150 milliseconds (ms) and less than 3 seconds in length. The silence gap between words is 150 ms. Voicetek warns that to achieve maximum speech recognition you must enunciate clearly and distinctly. When training is complete a playback option for each entry is provided that allows you to check the clarity of your entries. You can then test the system's ability to detect words corresponding to its stored vocabulary by speaking the words you just stored. The program will display each word it recognizes on the screen. (Remember that the system is trained to one person's voice, and others pronouncing the same words might be rejected.)

To test the system's ability to recognize digitized words, I performed two tests. One test used a vocabulary of 32 words that I entered; some of these entries were similar in sound. The second test used the same vocabulary, but my wife pronounced the words. The results are shown in table 1. Notice that the Cognivox recognized every word spoken by the trainer. This recognition rate of 100 percent is better than that claimed by Voicetek (98 percent). My wife was not as well received; the Cognivox recognized 8 words correctly, 7 in-



*Free job training  
is second nature  
to Alabama.*

*Gerald Cannon, Vice President of Operations, Dexter Lock, Division of Kysor Industrial Corp.; with family at Chewacla State Park, Auburn AL, home of Auburn University.*

Dexter Lock says a key to the extremely high productivity of its Auburn plant is a unique Alabama job training program. The state-funded program developed a proficient work force from scratch, beginning with screening. It followed with hands-on training in mobile classrooms and shops and continues with on-going screening, upgrading and renewal programs. Dexter Lock's Gerald Cannon credits the program for the plant's low 2% turnover and absenteeism rates

and extremely high productivity. Other significant benefits Mr. Cannon has found include: • Business oriented state government • An unequaled zero tax program • A total transportation network of roads, rail, air facilities, navigable rivers and a major ocean port • An abundance of engineers and technicians • State grants for industrial site development • High technology support industries.

Find your key to greater productivity in Alabama by writing for details.



**ALABAMA**  
*Cut out for business.*

Word	Voice A	Voice B
microprocessor	microprocessor	microprocessor
daisy wheel	daisy wheel	business
interface	interface	(no response)
graphics	graphics	graphics
digital	digital	(no response)
editing	editing	interface
computer	computer	computer
conclusions	conclusions	conclusions
analog	analog	(no response)
acquisition	acquisition	(no response)
harmony	harmony	monitor
directory	directory	(no response)
byte	byte	free
Apple	Apple	call
encyclopedia	encyclopedia	(no response)
inexpensive	inexpensive	(no response)
import	import	(no response)
call	call	call
heart	heart	(no response)
technology	technology	(no response)
sales	sales	(no response)
free	free	free
technical	technical	technical
costing	costing	(no response)
cost	cost	heart
matrix	matrix	(no response)
mountain	mountain	(no response)
monitor	monitor	graphics
BASIC	BASIC	(no response)
Pascal	Pascal	Pascal
professional	professional	(no response)
business	business	(no response)

**Table 1:** Voice response test results. The Cognivox had been programmed to respond to voice A (the author). When voice B (the author's wife) replaced voice A, the Cognivox usually responded with the wrong word or gave no response. The first column of the table lists the words actually spoken by both voices; the second and third columns show how the Cognivox interpreted voice A and voice B, respectively.

correctly, and failed to respond to 17. This is to be expected, of course, because the device works with masks of the trainer's voice.

### Demonstration Programs

The four demonstration programs included on the Cognivox program disk are VDUMP, VTRAP, VOTH, and TONES.

VDUMP is a voice-output program that reads selected locations of the Apple's memory. You enter the vocabulary (the hexadecimal numbers 0, 1, 2, 3, 4, 5, 6, 7, 8, 9, alpha, bravo, charlie, delta, echo, and fox), select the area of memory for review, and listen as the computer reads its own memory in your voice.

VTRAP is another voice-output program. This one is

in the form of an entrapment game. You enter a vocabulary of words that will control the moves of your player on the video display. To move in a particular direction you merely speak into the microphone and the player responds.

VOTH is an interactive game program that allows you and the computer to speak with each other. VOTH is actually the game of Reversi (also known as Othello). In this game the computer decides where it will place its piece and tells you the location. When you are ready for your turn, you tell the computer the coordinates of the location for your game piece.

TONES is actually not a demonstration program by itself. If used in conjunction with PROG4 or your own program, TONES permits dialing a Touch-Tone (a registered trademark of the Bell System) telephone with a simple connection to the phone line. TONES contains the corresponding tones for each of the 12 buttons on the telephone. By selecting the correct sequence, any number can be dialed.

Your own programs can be adapted to have voice output or speech recognition by following the steps provided in chapter 3 of the *User Manual*. Several routines are provided in the manual that can be spliced into your main program. These routines assist you in training the Cognivox to recognize your voice, developing a vocabulary for response, and setting memory locations. The instructions are clear, but you will probably have to read them twice before attempting the actual installation.

### Applications

The Cognivox could be used effectively in several applications, including security systems, aiding disabled persons, and games.

Because the Cognivox is trained to recognize voice patterns, it could be installed in security systems in place of key and combination locks. The device could be programmed to select a sequence of five words at random from a stored vocabulary. The person wishing to gain entrance to a room, safe, or computer would have to match the recorded patterns. (As shown in my test results, my wife would have a hard time getting into the family safe if it were protected in this fashion.)

Because the Cognivox operates in the audio mode and thus permits communications with the computer without the necessity of a video display or keyboard, applications for disabled persons abound. Using just the voice-output mode, the Cognivox could be helpful to those with poor eyesight. Blind people could communicate with the computer using the keyboard for input and the Cognivox for output. People unable to use the computer's keyboard could use the speech-recognition mode to communicate with the computer; the computer could either speak back or offer a display on the video screen. Now that government and educational institutions are becoming more and more committed to helping the disabled, Cognivox could play a significant role in training these people in computer science and computer-related occupations.





**A  
communications  
package  
that's slightly  
easier to use  
than  
MICRO/Terminal.**

**But  
a lot less  
functional.**

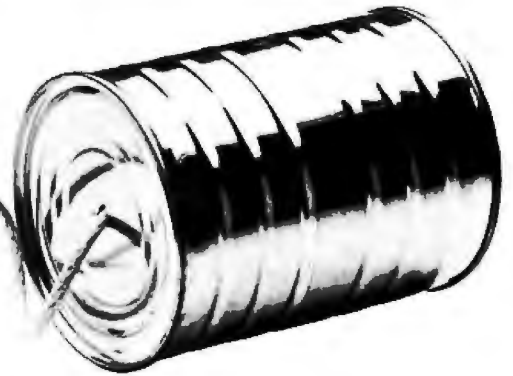

At MICROCOM we've made communicating with all kinds of computers easier and less expensive. Now, with MICRO/Terminal™, users of Apple II™, Apple III™ or IBM® Personal Computers can easily access any in-house or remote database. Directly, with a minimum of effort. With MICRO/Terminal, communications set-ups and log-on routines are entered only once. From then on they can be called up automatically. A built-in editor lets you change part of a program without re-doing all of it, and you can edit off-line.

Plus you can access your company computer and more than 1,000 commercial services. The price? Under \$100. So that by comparison with other systems, anything else is like talking through a tin can.

Just ask your computer dealer for more details.



**MICROCOM**  
We make little computers talk big.

1400A Providence Highway, Norwood, MA 02062

MICRO/Terminal is a trademark of MICROCOM, Inc. Apple II and Apple III are trademarks of Apple Computer Inc. IBM is a registered trademark of International Business Machines Corporation.

# Our Name Means a Great Deal

**consumer computers**  
MAIL ORDER 8338 Center Drive, La Mesa, CA 92041

**Toll Free ORDERS ONLY 800 - 854-6654**  
CALIFORNIA & INFORMATION (714) 698-8088

★ 15 Day No Risk Policy

★ We accept all major credit cards. ★ Most Orders Shipped Within 24 Hours

★ We will try to meet or beat any currently advertised price. ★ Free Shipping\* (Pre-Paid Cash Orders)

★ Serving people everywhere since 1977

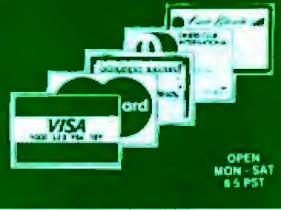

**NEC**

**IBM COMPATIBLE ACCESSORIES**

**Commodore**

**BASIS**

**VIC-20**

**NEW!**  
**PC-6000**  
The serious fun machine for living, learning, working and playing. Please call for details.

PC 8001A Microcomputer (32K) CALL  
PC 8031A Dual mini-disk drives CALL  
PC 8012A IO unit, 32K, 7 slots 139<sup>99</sup>  
FDC IO port 48<sup>99</sup>  
NEC 8003 Printer 18<sup>99</sup>  
32K Memory Add on card 48<sup>99</sup>  
Perf Tec 2 port RS 232 card 155<sup>99</sup>  
Perf Tec Wedge Expansion w/32K 48<sup>99</sup>  
RGB to Composite Video Converter 129<sup>99</sup>

**NEC PC-8001 Software**

NEC CP/M Operating System 125<sup>99</sup>  
FORTRAN by Microsoft 349<sup>99</sup>  
General Accounting System 249<sup>99</sup>  
Accounts Receivable System 249<sup>99</sup>  
Inventory Control System 249<sup>99</sup>  
Payroll System 249<sup>99</sup>  
Job Cost System 249<sup>99</sup>  
Select Word Processing assembler 349<sup>99</sup>  
Report Manager 149<sup>99</sup>  
Games Pack 1 Alien, Space War 29<sup>99</sup>  
Games Pack 2 UFO Galaxian Bomber 29<sup>99</sup>  
WordStar by Micropro 289<sup>99</sup>  
DataStar by Micropro 289<sup>99</sup>  
Mailmerge for NEC Wordstar 109<sup>99</sup>  
Spellstar by Micropro 169<sup>99</sup>  
Superstar by Micropro 169<sup>99</sup>  
Basic-80 Compiler by Microsoft 349<sup>99</sup>  
Basic-80 by Microsoft 319<sup>99</sup>  
Cobol 80 by Microsoft 649<sup>99</sup>  
Rascal NEC DOS 139<sup>99</sup>  
Term II Communications Pkg 149<sup>99</sup>  
FireFax System 149<sup>99</sup>  
Protran (converts TRS 80 software) 99<sup>99</sup>  
KF580 ISAM Package 139<sup>99</sup>

More Software and Accessories everyday

**IBM compatible software**

64K memory card by Microsoft 379<sup>99</sup>  
128K memory card by 499<sup>99</sup>  
192K memory card by 659<sup>99</sup>  
256K memory card by 799<sup>99</sup>  
64K ram chip upgrade kit 169<sup>99</sup>  
Serial Async Comm card w/1 port 129<sup>99</sup>  
Serial Async card with 2 ports 249<sup>99</sup>  
Clock Calendar card 105<sup>99</sup>  
Combo Card by Apparat 235<sup>99</sup>  
IBM Joysticks 55<sup>99</sup>  
Expansion Chassis 189<sup>99</sup>  
Baby Blue Z-80 w/64K & CP/M CALL  
Percom mini floppy drives (add on) CALL  
Tandon TM 100 mini floppy drives CALL

**NEW!**  
**COMMODORE 64**  
The Commodore 64 is a compact unit that is worth its into a basic case. Complete with these features:

- Full size typewriter keyboard
- Full ASCII character set
- Upper and lower case
- High resolution color graphics
- 60 line video display
- 64K RAM (under memory standard)
- CP/M operating system option
- TV monitor interface
- Game cartridge slot
- Multi-Sync/Reset
- Smart peripherals

PLEASE CALL US FOR MORE DETAILS

**The Alternative**

- Apple II compatibility in both peripheral cards and software
- 4802 and Z-80 CPUs
- 64K RAM expandable to 128K
- RGB and Composite Video Output
- Selectable 80 or 40 column display
- High Resolution Graphics, 6 colors, 280 x 192 with four lines of text
- 8 bit Parallel IO interface
- Detachable Keyboard. All standard ASCII characters and keyboard functions.
- Upper/lower case and numeric keypad control block, and 15 programmable special function keys
- Built in hardware for mounting two 5 1/4 inch mini floppy disk drives
- Six Apple II compatible slots for plug in peripheral cards

Please call or write for more details.

**The Friendly Computer**

**\$244<sup>50</sup>**

VIC 20 Personal Computer 244<sup>50</sup>  
VIC 1540 Single Disk Drive 489<sup>99</sup>  
Datasec II Cassette IO unit 65<sup>99</sup>  
Joystick Controller 19<sup>99</sup>  
VIC 1515 Graphics 329<sup>99</sup>  
VIC Super Expander 54<sup>99</sup>  
JK Ram Cartridge 34<sup>99</sup>  
BK Ram Cartridge 49<sup>99</sup>  
18K Ram Cartridge 99<sup>99</sup>  
VIC IEEE-488 interface 79<sup>99</sup>  
VIC RS-232C Terminal Interface 39<sup>99</sup>

**umi**  
UMI SOFTWARE FOR VIC-20

V-Calc - Viable Calculator (T) 11<sup>99</sup>  
V-Check - Viable Catalog (BK) (T) CALL  
V-Term - Viable Terminal (T) 18<sup>99</sup>  
Basic Programmers Utility ROM 27<sup>99</sup>  
Sports of Mars (C) 39<sup>99</sup>  
AMOK (C) 31<sup>99</sup>  
AMOK (T) 19<sup>99</sup>  
Moleton Run (C) 28<sup>99</sup>  
Alien Blitz (C) 18<sup>99</sup>  
Alien Blitz (T) 18<sup>99</sup>  
Simon (T) 7<sup>99</sup>  
Kiddie Checkers (T) 7<sup>99</sup>  
3-D Maze (T) 11<sup>99</sup>  
Raceway (T) 11<sup>99</sup>  
Kosmic Kamikaze (BK/T) 20<sup>99</sup>  
Kiddie Pak 1 (4 Tapes) 31<sup>99</sup>  
Super Four (4 Tapes) 29<sup>99</sup>  
The Alien (BK/T) 19<sup>99</sup>  
Renaissance Omnio (C) 29<sup>99</sup>  
SkyMath (BK T) 12<sup>99</sup>  
Long Drive (BK T) 12<sup>99</sup>  
SpaceDw (BK/T) 12<sup>99</sup>  
Super Hangman (BK/T) 17<sup>99</sup>  
T = Tape, C = Cartridge, BK = 3K expansion

**TERMINALS**

**ADDS**  
Viewpoint A1 879<sup>99</sup>  
Viewpoint A2 699<sup>99</sup>  
Viewpoint A3 599<sup>99</sup>

**TeleVideo**  
910C 599<sup>99</sup>  
912C 729<sup>99</sup>  
920C 799<sup>99</sup>  
925C 789<sup>99</sup>  
950C 995<sup>99</sup>

**MicroPro**  
Wordstar by MicroPro 299<sup>99</sup>  
MailMerge by MicroPro 129<sup>99</sup>

**VICAR**  
Vic Car (Standard) 199<sup>99</sup>  
Vic Car (256K) 199<sup>99</sup>  
Vic Trend Plus 239<sup>99</sup>  
Vic Dex 199<sup>99</sup>  
Vic File 199<sup>99</sup>  
Desktop Plus 249<sup>99</sup>

**FRANKLIN ACE 100**

The Franklin ACE 100 is a professional personal computer that is hardware and software compatible with the Apple II and includes many features not found on the Apple unit. All programs written for the Apple II will run on the ACE 100 without modification, those using high and low resolution black and white graphics. The ACE 100 is plug compatible with Apple II peripherals that operate in the Apple II slot.

**FRANKLIN ACE 100 FEATURES**

- Apple II Compatible
- 64K RAM memory
- Upper and lower case
- Typewriter style keyboard
- Tapewrite key numeric pad
- Sliding lock shift key
- V-Calc II Transp.
- 60 watt power supply
- Built in fan

**S-100 BOARDS CLEARANCE SALE**

**ESM**

Z-80 AMN CPU Card (CB2), A&T 239<sup>99</sup>  
VB3 80x24 S 100 Video Card A&T 349<sup>99</sup>  
VB3 80x48 S-100 Video Card, A&T 399<sup>99</sup>  
ExpandoRam 64K Dynamic Memory Kit 199<sup>99</sup>

**MODEMS**

Anchor Automation Signalman Mark I 89<sup>99</sup>

**Novation**  
Novation Cat acoustic modem 149<sup>99</sup>  
Novation D-Cat direct connect 149<sup>99</sup>  
Novation Apple Cat 319<sup>99</sup>

**Hayes**  
Hayes Stack Smartmodem 249<sup>99</sup>  
Hayes Stack Chromograph 199<sup>99</sup>  
Hayes Apple Micromodem II 289<sup>99</sup>

**TERMINALS**

**ADDS**  
Viewpoint A1 879<sup>99</sup>  
Viewpoint A2 699<sup>99</sup>  
Viewpoint A3 599<sup>99</sup>

**TeleVideo**  
910C 599<sup>99</sup>  
912C 729<sup>99</sup>  
920C 799<sup>99</sup>  
925C 789<sup>99</sup>  
950C 995<sup>99</sup>

**NEW!**  
**SANYO computer**

Please call for details

**We are a full-line Commodore Dealer.**  
**Please Call For More Information**

**S-100 BOARDS CLEARANCE SALE**

**ESM**

Z-80 AMN CPU Card (CB2), A&T 239<sup>99</sup>  
VB3 80x24 S 100 Video Card A&T 349<sup>99</sup>  
VB3 80x48 S-100 Video Card, A&T 399<sup>99</sup>  
ExpandoRam 64K Dynamic Memory Kit 199<sup>99</sup>

**MODEMS**

Anchor Automation Signalman Mark I 89<sup>99</sup>

**Novation**  
Novation Cat acoustic modem 149<sup>99</sup>  
Novation D-Cat direct connect 149<sup>99</sup>  
Novation Apple Cat 319<sup>99</sup>

**Hayes**  
Hayes Stack Smartmodem 249<sup>99</sup>  
Hayes Stack Chromograph 199<sup>99</sup>  
Hayes Apple Micromodem II 289<sup>99</sup>

**consumer computers**

**Call or Write for Free Catalog**

Ordering Information: Phone orders using VISA, MASTERCARD, AMERICAN EXPRESS, CARTE BLANCHE and bank fund wire transfer. Send cashiers or certified check, money order or personal check (allow ten days to clear). Unless prepaid with cash please add 5% for shipping, handling & insurance (minimum \$5.00). California residents add 6% sales tax. Foreign customers please add 10% for shipping & export documentation (minimum \$50.00). Educational Institutions and Corporations please send for written quotations. All equipment is subject to price change and availability without notice. All equipment is new and complete with manufacturer's warranty (usually 90 days). We will not honor prices which are typographical errors. C.O.D. orders require a 20% cash deposit in advance. If you are not completely satisfied, return product within 15 days for a refund (only with original container and completed warranty card — Applies to hardware items only — No returns on software). All other returns subject to a restocking fee. Please call for more details.  
Send Orders to 8338 Center Drive, La Mesa, CA 92041

**We Bring Prices Down to Earth**

**Universal Data Systems**  
Direct Connect Modems

103 LP Orig (A&T) 300 baud 169<sup>99</sup>  
103 LP Orig (A&T) ans. 300 baud 189<sup>99</sup>  
232 LP Orig (A&T) 1200 baud 229<sup>99</sup>  
2025 LP Orig (A&T) ans. 1200 baud 249<sup>99</sup>

**DISKETTES**

Dysan 5 1/4 (50) 10 or 16 sector 1029<sup>99</sup>  
Dysan 8 3/4 Den 5 1/4 Sided 1054<sup>99</sup>  
Verbatim 5 1/4 (50) 10 or 16 sector 1029<sup>99</sup>  
Verbatim 8 3/4 Den 5 1/4 Sided 1054<sup>99</sup>  
Scotch 3 1/2 x 5 (50) 10 or 16 Sect 1029<sup>99</sup>  
Same as above in quantity of 100 245<sup>99</sup>  
Scotch 3 1/2 x 5 Disks all types CALL  
Scotch 3M Drive Head Cleaning Kit 29<sup>99</sup>

# Buy From Us and Save Your Green

**Consumer Computers**  
MAIL ORDER 833 Center Blvd., #100, San Jose, CA 95128

**Toll Free ORDERS ONLY 800-854-6654**  
CALIFORNIA & INFORMATION (714) 698-8088

\* 15 Day No Risk Policy

\* Serving people everywhere since 1977

\* We accept all major credit cards.

\* Most Orders Shipped Within 24 Hours

\* We will try to meet or beat any currently advertised price.

\* Free Shipping\* (Pre-Paid Cash Orders)



OPEN MON-SAT 9-5 PST

## 16K RamBoard FOR APPLE II



**\$50.00 KIT**

ASSEMBLED & TESTED \$69.00

## APPLE SOFTWARE



VisiCalc	185.00
VisiFile (Data Base Manager)	185.00
VisiTrend/VisiPlot	199.00
VisiSchedule (New!)	239.00
VisiTerm	89.00
VisiData	185.00
Desktop Plan II	185.00



Tax Preparer	119.00
Real Estate Analyzer	139.00
Creative Financing	119.00



WordStar by MikroPro	199.00
MailMerge by MikroPro	79.00
SpellStar by MikroPro	115.00
DataStar by MikroPro	169.00
CalcStar by MikroPro	115.00
Supersort I by MikroPro	115.00
WordStar Customization Notes	289.00



**MICROSOFT SOFTWARE PREMIUM SYSTEM**  
(Includes: Software, RAMCard, Video)

Videoterm 80 Col., Softswitch, Osborne CPIM User Guide) List 755.00 only 659.00	
Microsoft TASC Applesoft Compiler	149.00
Fortran 80	89.00
A.L.D.S.	89.00
Basic Compiler	269.00
Code80	499.00
Time Manager	129.00

Super Text II Word Processor Mute	119.00
PFS: Personal Filing System	79.00
PFS: Report	79.00
DB Master	169.00
Systems Plus Accounting Software	CALL
Peacemaker Accounting Software	CALL
Continental Accounting Plus	189.00

## CP/M Software



WordStar	289.00
Supersort	189.00
MailMerge	79.00
DataStar	239.00
SpellStar	115.00
CalcStar	115.00

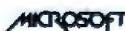

BASIC 80	269.00
BASIC Compiler	309.00
Fortran 80	339.00
Code80	509.00
Macro 80	179.00
mu Math/MS BMP	215.00
mu LSP/MS STAR	169.00

d BASE R	499.00
PLAN 80	249.00
CBASIC	399.00
PASCAL MT - Ver 5.5	399.00
Spellguard	299.00
PASCAL Z	329.00
SUPERCALC	229.00

## APPLE II COMPATIBLE Accessories



Hayes MicroModem II	289.00
Hayes Chromograph	189.00



Novation Apple Cat modem	319.00
Expansion Mod	29.00
Handset	29.00
BSR X-10 control interface mod	19.00
Touch-Tone Firmware	CALL



Vindex VideoTerm 80 column card	249.00
Vindex Keyboard Enhancer I (orig)	79.00
Vindex Keyboard Enhancer II	129.00



Z-80 SoftCard by Microsoft	369.00
16K RamCard by Microsoft	155.00
ThunderClock Calendar card	189.00
Smarterm 80 column card	389.00



Corvus Winchester 8 Mb Disk	295.00
Corvus Winchester 10 Mb Disk	429.00
Corvus Winchester 20 Mb Disk	619.00
Mirror Back-Up	699.00



CP/M Multi-Function Card	189.00
Music System (16 voices)	299.00
A/D - D/A Interface	279.00
Expansion Chassis (8 slots)	569.00
Clock/Calendar card	249.00
SuperTalker SD-200	149.00
Romplus - card	129.00
Keyboard Filter ROM for Romplus	49.00
CopyRom for Romplus	149.00
RomWriter card	149.00
RamPlus 32K ram add-on (w/16K)	149.00



Sorrento Valley Associates	CALL
SV4 2 - 2 Sgl Den B Disk Cont.	CALL
SV4 SVX4 Megabyte 8 Disk Cont.	CALL
Apple Cache 256K by SV4	CALL



Port (Apple compatible) Drives	CALL
IEEE 488 Interface by SSVA	389.00
Vision 80 Col. card by Vista	259.00
Port Development System by Vista	359.00
8" Disk Drives by Vista	CALL
Advar Video Processor Mod	CALL
Videodisk Apple Interface	479.00
Echo II Speech Synthesizer	219.00
Symtec Lightpen	319.00
Laser Lower Case Adapter	55.00
Houston Inst. Graphics Plotter	CALL
16K RAMBoard assembled & tested	89.00
16K RamBoard by CCI in kit form	99.00
SYNERGY Multi-Card	CALL
Primetrek VHS Card	249.00
ALF 3 Voice Music Card	179.00
ALF 9 Voice Music Card	189.00
Joysticks by Keyboard Co.	49.00
23 Key Numeric Keypad by Versawriter	119.00
Versawriter Digitizer Table	249.00
Grapple Printer Interfaces	139.00
MicroBuilder II 32K (specify printer)	289.00
MicroBuilder II 16K (specify printer)	249.00
16K Serial Buffer Card for Epson	149.00
16K Parallel Buffer I/F for Epson	149.00
Sup-R Fan	49.00
Sup-R Terminal 80 column card	289.00

We have more items too Please Call Us

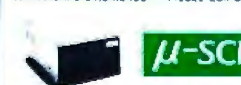

**MICRO SCI APPLE II COMPATIBLE DISK DRIVES**

A2 with controller	469.00
A2 w/o controller	399.00
A4 with controller	479.00
A4 w/o controller	399.00
A70 with controller	599.00
A70 w/o controller	499.00

## Clearance Sale!



**Clearance**

Up To **40% OFF!**

*This Offer Good While Supplies Last*

Asynchronous Serial Card (7170A)	129.00
Synchronous Serial Card (7170B)	89.00
Centronics Printer Card (7728A)	89.00
Cable for Prism/7-gers to 7728A	29.00
Parallel I/O Card (7720A)	89.00
Calendar/Clock Card (7424A)	79.00
Arithmetic Process (7811C)	269.00
Programmable Timer Card (7440A)	69.00
3 1/2" Disk BCC A-D Converter	89.00
QPIB (IEEE 488) Card (7492A)	169.00
12K ROM/PROG Card (7114A)	19.00
Extender Card (7520A)	19.00

## HARDWARE from APPLE COMPUTER

**SAVE UP TO 50% Clearance Sale**

Parallel Printer Card	89.00
Hi-Speed Serial Card	89.00
Centronics Printer Card	119.00

## APPLE II SPECIAL DELIVERY SOFTWARE

**CLEARANCE SPECIAL SAVE over 50% OFF!**

Pascal Animation Tools	37.00
PSORT Pascal disk top sort	42.00
Formulas	37.00
Goodspell	30.00
Plan 80	82.00
Order Tracking System	32.00
VisiCalc Real Estate Templates	32.00
Hand Holding Basic	50.00
Supemap	17.00
Pilot Animation Tools	37.00
Topographic Mapping	20.00
Bridge Tutor	20.00
Bridge Tutor Extended	32.00
Artist Designer	17.00
Galactic Wars	17.00
Utopia Graphics Tablet System	27.00
Diet Analysis	22.00
Stepwise Multiple Regression	78.00

We have many Apple Computer software at great & reduced prices. Please call!

## APPLE II GAMES SOFTWARE CLEARANCE

We are reducing our inventory of software at incredible savings to you. Hurry we have a limited supply!

**ANY GAME ONLY \$15.00**

Galactic Trader (Brodarbund)	16.00
Galactic Revolution (Brodarbund)	16.00
Galaxy Wars (Brodarbund)	16.00
Tactics at Last (Brodarbund)	16.00
Golden Mountains (Brodarbund)	16.00
Space Invaders (Cosmos Mission)	16.00
Head-On	16.00
SmulHebboard	16.00
MicroChess	16.00
Bridge Partner	16.00
Monty Plays Scrabble	16.00
Monty Plays Monopoly	16.00
Rainbow Writer	16.00
Checker King	16.00
Gummi Gumbler	16.00
Fasthammer	16.00
Bright Pen Light pen	16.00
Both Barrais	16.00

## PRINTERS



DP-9501 w/2K buffer	1149.00
---------------------	---------



F-10 40 CPS (parallel)	1399.00
F-10 40 CPS (serial)	1459.00
ProWriter 8510 10" (parallel)	489.00
ProWriter 8510 10" (serial)	579.00
ProWriter II 1550 15" (parallel)	699.00
ProWriter II 1550 15" (serial)	749.00



MX-80 T Type III w/graphics	CALL
MX-80 FT Type III w/graphics	CALL
MX-82 FT Type III w/graphics	CALL
MX-100 Type III w/graphics	CALL
EPSON Graffiti 80 ROM	59.00



Prism 80 without color option	1049.00
Prism 80 with color	1299.00
Prism 132 with color	1899.00
Apple Prism color software	69.00



8023 Impact Dot Matrix	459.00
3510 33 CPS serial	1749.00
3530 33 CPS centronics parallel	229.00
8-directional tractor for 3500's	229.00
7710 55 CPS serial	2349.00
7730 55 CPS centronics parallel	2349.00
Tractor for 7700 series	229.00



Okidata MicroLine 80 (for queue)	519.00
Okidata 82A tractor, 80 col	469.00
Okidata 83A tractor, 132 col	729.00
Okidata 84A 132 col serial	1199.00
Okidata 84A 132 col parallel	1029.00



Smith Corona Printer Parallel	849.00
-------------------------------	--------

## MONITORS



Amdek Video 300 12" Hi-Res Green	169.00
Amdek Video 100 12" B&W	129.00
Amdek Color II 13" Color w/audio	379.00
Amdek Color II Hi-Res RGB monitor	799.00
Amdek Apple II DVM RGB card	169.00



NEC 8" Hi-Res Green monitor	179.00
NEC 12" Hi-Res Green monitor	169.00
NEC 12" Composite Color monitor	349.00
NEC 12" Hi-Res RGB color monitor	799.00



Sanyo 8" B&W	169.00
Sanyo 8" Green monitor	179.00
Sanyo 12" B&W	169.00
Sanyo 12" Green (New case style)	289.00
Sanyo 13" Color Monitor	269.00



Zenith 12" Green monitor	119.00
--------------------------	--------

## ATARI



Atari 800 (16K)	679.00
Atari 800 w/32K 729.00 w/4K 729.00	729.00
Atari 400 (16K)	329.00
811 80 Column Card for 800	299.00
410 Program Recorder	79.00
410 Disk Drive	429.00
850 Interface Module	189.00
Epson cable for 850 module	24.00
Atari Joystick (pair)	39.00
Atari RomCartr 32K module	149.00
Atari 16K Module by Microtek	69.00

## ATARI Software

EDU-PAK Educational 14 Tape Series	169.00
VisiCalc for Atari (D)	189.00
Word Processor (D)	119.00
Personal Finance Management (D)	47.00
Macro Assembler & Test Editor (D)	89.00
Microsoft Basic (D)	89.00
Conversational Spanish (T)	49.00
Conversational French (T)	49.00
Conversational German (T)	49.00
Conversational Italian (T)	49.00
Conversational Spanish (T)	49.00
Pac-Man (cartridge)	34.00
Centipede (cartridge)	34.00
Asteroids (cartridge)	34.00
Mission Command (cartridge)	34.00
Star Raiders (cartridge)	34.00
Space Invaders (cartridge)	34.00
Caverns of Mars (disk)	34.00
Assemble-Editor (cartridge)	49.00

We carry all ATARI software and hardware.



## Control Everything in your Home

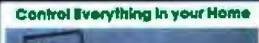

BSR Ultrasonic Command Console	39.00
BSR Appliance Module	18.00
BSR Lamp Module	17.00
BSR Timer Module	69.00

## SUPPLIES

Orange AC Surge Protector 6	119.00
Lemon AC Line Filter	59.00
Executive Library Case 5 1/2"	24.00
Dummy Cables (all sizes)	CALL
Plexiglass cover for Apple II	24.00
5 1/4" Disk Bank Storage Box	9.00
8" Disk Bank Storage Box	9.00

**GENERAL RIBBON PRODUCTS**

NEC Multi-Strike Ribbon	6.00
NEC Black Fabric Ribbon	6.00
Dume Multi-Strike Ribbon	4.00
Dume Black Fabric Ribbon	6.00
Diablo Multi-Strike Ribbon	6.00
Diablo Black Fabric Ribbon	6.00
Anadex DP-9500 Cartr. Ribbon	1.50
C-1ton 8000 Nylon Ribbon	6.00
IBM 2020-2022 Nylon Ribbon	9.00
Paper Tiger Black Nylon Ribbon	3.00
Epson MX100 Cartridge Ribbon	12.00
Epson MX-100 Cartridge Ribbon	24.00

**DUST COVERS**

Apple II	9.00
Disk II Only	12.00
Apple II & 2 Drives	15.00
Apple IIe Disk Cover	12.00
Apple III Computer	12.00
Epson MX-80 Cover	11.00
Sanyo 8" Monitor cover	9.00
Atari 800	9.00
Televideo Terminal	10.00
Amdek 12" B&W	10.00
NEC 12" & NTSC Color	14.00
Diablo 850 Printer	9.00
NEC RGB Color Monitor	14.00
Epson MX-100 Cover	14.00

# Microline 82A



**\$439<sup>88</sup> UPS DELIVERED**

- OKIGRAPH Dot-addressable ROM . . . . \$44<sup>88</sup>
- Adjustable Tractor . . . . . \$59<sup>88</sup>
- Roll Paper Holder . . . . . \$49<sup>88</sup>

## Okidata Printers

- MICROLINE 80 . . . . . \$339<sup>88</sup>
- MICROLINE 83A . . . . . \$699<sup>88</sup>
- ML83A OKIGRAPH ROM . . . \$44<sup>88</sup>
- RS-232C 2K BUFFER . . . . \$159<sup>88</sup>
- MICROLINE 84 Parallel  
200 cps . . . . . \$1049<sup>88</sup>
- MICROLINE 84 RS-232C  
200 cps . . . . . \$1169<sup>88</sup>

## Anadex Printers

- DP-9500A . . . . . \$1459<sup>88</sup>
- DP-9510A . . . . . \$1459<sup>88</sup>
- DP-9620A . . . . . \$1554<sup>88</sup>
- WP-6000 . . . . . \$2999<sup>88</sup>

## Brother Printers

- DAISYWRITER 1500  
Parallel only . . . . . \$979<sup>88</sup>
- DAISYWRITER 2000—With  
Parallel, RS-232C, IEEE488  
& Current Loop Interface \$1099<sup>88</sup>
- TRACTOR . . . . . \$149<sup>88</sup>

## Centronics Printers

- CENTRONICS 122 . . . . . \$989<sup>88</sup>
- CENTRONICS 739  
Parallel Interface . . . . . \$559<sup>88</sup>
- CENTRONICS 739  
RS-232C Interface . . . . . \$679<sup>88</sup>
- 739 COLOR OPTION . . . . . \$79<sup>88</sup>

## IDS Printers

- PRISM 80 . . . . . \$999<sup>88</sup>
- Includes Sprint Mode, Dot Plot,  
and Cut Sheet Guide
- PRISM 132 . . . . . \$1699<sup>88</sup>
- 4-Color Graphics, Sprint Mode,  
Dot Plot, and Cut Sheet Guide

## CALL FOR PRICES

On NEC Spinwriters, QUME & DIABLO Daisywheels. QUANTEX, DATASOUTH, DIP, MPI and other printers available.

**Orders & Information: CALL (603)-673-8857**

**Orders Only: (800)-343-0726**

No surcharge for credit cards—No charge for UPS shipping—Stock shipments next day All equipment shipped factory fresh with manufacturer's warranty—Minimum \$50 per order—Open PO's not accepted—No foreign orders accepted We accept CODs

HIGH TECHNOLOGY AT AFFORDABLE PRICES

# THE BOTTOM LINE

Milford NH 03055-0423

## TEC Printers



- DMP85 . . . . . \$479<sup>88</sup>
- Generic version of NEC & Pro-writer printers. Features 120 cps, bi-directional, logic-seeking, 1.3K buffer. 5 fonts, 8 sizes on 9x9 matrix, w/proportional print, true descenders, & Greek/Math font. 160 x 144 dots/inch Hi-Res graphics matrix, 1/144" line feed. Friction & tractor standard, rear paper path. Parallel only.

- NEC PC-8023A-C . . . . . \$509<sup>88</sup>
- CJTOH PROWRITER . . . . . \$509<sup>88</sup>
- CJTOH PROWRITER  
Parallel & RS-232C . . . . . \$664<sup>88</sup>
- CJTOH PROWRITER 2 . . . . . \$739<sup>88</sup>
- CJTOH PROWRITER 2  
Parallel & RS-232C . . . . . \$799<sup>88</sup>
- F-10/40 STARWRITER 40cps  
Parallel or RS-232C . . . . . \$1494<sup>88</sup>
- F-10/55 PRINTMASTER 55cps  
Parallel or RS-232C . . . . . \$1799<sup>88</sup>
- F-10 TRACTOR . . . . . \$289<sup>88</sup>

## Smith-Corona

- SMITH CORONA TP-1 . . . . . \$649<sup>88</sup>
- Specify 10 or 12 cpi
- Specify Parallel or RS-232C

## Microfazers

- Stand-alone print/data buffers
- 8K MICROFAZER . . . . . \$144<sup>88</sup>
- 8K MICROFAZER (RS-232C  
to Parallel) . . . . . \$184<sup>88</sup>
- 16K MICROFAZER . . . . . \$164<sup>88</sup>
- 32K MICROFAZER . . . . . \$184<sup>88</sup>
- 64K MICROFAZER . . . . . \$229<sup>88</sup>
- ADAPTER CABLE . . . . . \$14<sup>88</sup>

The Cognivox's potential extends to game applications as well. The two games included on the demonstration disk should only whet the appetite of game enthusiasts everywhere. Imagine moving game pieces by using a microphone instead of the keyboard. Computer graphics could be twice the fun if you controlled the sketching by yelling "up," "down," "left," "right," and so on. Think how exciting a game of vocal chess might be.

## System Limitations

A number of limitations in the system become apparent after a few minutes of use. First, the audio quality of the built-in amplifier and speaker is awful. Voicetek recommends that the Cognivox be connected to a high-quality stereo system for improved performance. The only problem with this suggestion is that my stereo system is on the second floor and my office is on the first floor. The poor quality of the audio should have the highest priority for the first revision of the product.

Voicetek promotes the interface of the Cognivox to the Apple by declaring, "It plugs into the game I/O port in the Apple and does not use up the valuable peripheral slots." Now that's a clever advertising ploy of accentuating the positive while downplaying the negative. Most of us have a peripheral slot or two to spare, but how many game I/O ports did you get with your Apple? If the Cognivox is installed, you must give up your joysticks, game paddles, and simple computer control of output circuits. This is a major loss if you want to control motors or relays from a vocal alarm circuit. It also limits how far you can go in flexible game design because you must give up the push buttons.

I decided to take the Cognivox apart to see what Voicetek had used for an audio amplifier; the two screws holding the unit together weren't much of a challenge. It looked like someone had spilled a milkshake on the inside of the case: all the critical parts had had their numbers either filed off or coated with a hard plastic material. The Cognivox must be the hardware counterpart of the protected disk. If you have ever lost a chip or two because of static electricity, you know how convenient it is to be able to quickly repair your equipment by direct substitution of components. You won't be able to do this if the Cognivox breaks down; you'll have to return the device to the factory for repair, which will cost you time and money.

## Conclusions

The Cognivox VIO-1003 is what the manufacturer claims it to be—a state-of-the-art speech-recognition and voice-output peripheral for the Apple II computer. The Cognivox records voice masks during a training session and stores these on disk for future voice output or speech recognition. Once trained to a voice, the recognition rate is very high (98 to 100 percent) for a device that uses approximately 4K bytes of storage for programs and tables.

The Cognivox should open new vistas for security systems, aid to disabled persons, and computer games. ■

# Disk Storage Needn't Double The Cost Of Your Apple III\*™



Expanding disk storage on your Apple III\*™ can be an expensive proposition.

But Micro-Sci has a better proposition for you, because our disk drives for the Apple III give you greater capacity and performance for every dollar spent.

And no compatibility problems. The A3 is a direct replacement for Disk III drives, and the 70-track A73 and 140-track A143 are supplied with a driver that is easily added to the SOS driver module, affording extra storage and fast seek rates for all of

the programs that run under that operating system. All three are the same 5 1/4" size as your built-in drive and use the same diskettes.

They also use your Apple III's controller and power, saving an expansion slot and no AC power



card. And they can be mixed in any combination on the daisy-chain. At 572 KBytes, the A143 makes a truly viable backup device for the ProFile Hard Disk.

At 286 KBytes, the A73 gives you a lot more capacity than a Disk III drive.

The A3 offers identical capacity — and is an excellent choice for second drive compatibility in the Apple II emulation mode.

So see your Micro-Sci dealer today. He'll show you how to up your Apple III's performance the affordable way.

\*Registered Trademark of Apple Computers, Cupertino, California

**μ-SCI**  
**MICRO-SCI**

Micro-Sci is a Division of Standun Controls, Inc.

2158 SOUTH HATHAWAY STREET • SANTA ANA, CALIFORNIA 92705 • 714/662-2801 • TELEX: 910-346-6739

International Dealer Inquiries IMC International Markets Corp. Telephone: 714/730-0963

Circle 311 on Inquiry card.

## The Abilityphone

---

William L. Rush  
817 C St., Apt. 1  
Lincoln, NE 68502

---

I had awakened in the middle of the night with stomach cramps. To an able-bodied person, getting up would have posed no particular problem. But I have athetoid cerebral palsy: I'm a person who is a quadriplegic as well as unable to speak. As a result, an otherwise minor case of cramps became a cause for alarm.

I waited and prayed for the attack to subside. When it didn't, I groaned, hoping I could arouse the student assistant for my dorm floor. I hated to wake him up at 2 a.m., but I didn't have much choice. The cramps grew stronger and more frequent by the minute, and sweat began running off my body. Why hadn't I taken a class in Lamaze breathing? Finally, my groans alerted the student assis-

tant, who came into my room and asked, groggily, "What's wrong, Bill? Are you too hot?"

I shook my head "No."

"Is something wrong with your electric wheelchair and how it's charging?"

"Is something wrong with your voice synthesizer?"

"Is something wrong with your door opener?"

"Is something wrong with your physical body?"

I nodded "Yes" to his last question.

"If I call your attendant, would she know what to do? Great. What's her number? Oh, you can't tell me that, can you? How do I call her for you?" A mixture of frustration and fatigue was in his voice. His training hadn't covered situations like this.

I looked in the direction of my new Abilityphone, which had my personal-service aide's number stored somewhere in its electronic memory. The student assistant only had to push the button marked "Help," and the phone would do the rest. He was trying to find the number when he spied the Help key and asked, "If I push this 'help' button, will the phone give me your aide's number?"

I nodded "Yes." He pushed the button with a picture of a hand on it (so it can be spotted easily in an emergency).

---

### About the Author

*William L. Rush is a senior studying journalism at the University of Nebraska-Lincoln as well as a freelance writer. He has a personal interest in electronic aids for people with disabilities because he has cerebral palsy. In addition to the Abilityphone, he uses a personal computer as a voice synthesizer and a word processor.*

---



Photo 1: The author at work. The Abilityphone appears in the background.

# 36Mhz Z-80



## Parallel multiprocessor power.

We've put nine 4 Mhz Z-80's working in parallel to give you this performance. Here's the key: eight SLAVENET™ processors, each a complete S-100 computer that can handle two timeshared users, with 128K RAM plus parity, 2K EPROM, full interrupts, software bank boundary and two serial ports for synchronous and asynchronous protocol.



simultaneous and independent users. Our operating system includes such features as semaphores, concurrency, chaining and true word processing. And

we have an impressive library of applications software too.

backup. Get up to 100 Mbytes on a single videotape cartridge.

## Get the most computer bang for the buck.

That's because you can get started with a low-cost, single user system and grow from there. Just plug in boards to go from one to sixteen users. And we've made it easy to reconfigure our I/O system so you can interface a remarkable

variety of peripherals and controllers without special programming.

## PASCAL & CP/M™

We have full compatibility with UCSD PASCAL II™ and CP/M™ through IBS PASCAL™ and TURBODOS™, which are fully interrupt driven, allowing up to 16

## Store up to 600 Mbytes on hard disk.

Hang on 5", 8" or 14" Winchester disk drives with from 5 Mbyte to 600 Mbyte storage. Or go with 5" or 8" floppies. With our system you can even use your video tape recorder for

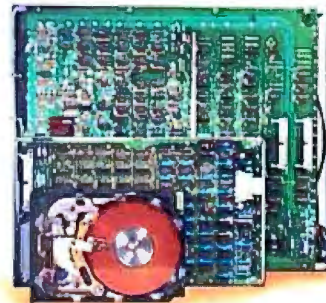

# ibs

**INDEPENDENT BUSINESS  
SYSTEMS**

**(415) 443-3131**

5915 Graham Ct.  
Livermore, CA 94550

**OUR DEALERS:** DOMESTIC • CEB3, Los Gatos, CA, (408) 559-0288 • Donald Coffman, Cupertino, CA (408) 253-2327 • ICE, Galthersburg, MD, (301) 869-2896 • QUALITY-TE, Livermore, CA, (415) 447-6121 • ERS, Brea, CA, (714) 524-2470 • Innovative Interfaces, Berkeley, CA, (415) 524-8416 • Khalsa Consultants, Cambridge, MA, (617) 235-3580 • Khalsa International, Herndon, VA, (703) 437-4177 • FOREIGN • Philip Baksh, London, England, Tel: 44 1 7413707 • EEI, Sharjah, United Arab Emirates, Tel: 971 6 354 688 • JH Systems, Etobicoke, Ontario, Canada, Tel: (416) 621-0538 • ELIF, Inc., Montreal, Quebec, Tel: (514) 337-3214 • FOM, Madrid, Spain, Tel: 34 1 255 14 04 • Micro Service, Saint-Clement La Riviera, France, Tel: 33 87 84 31 88 • Servonic, Munich, Germany, Tel: 37 089 483253 • Terrace Computer Services, Terrace, British Columbia, Canada, Tel: (604) 635-7606 • Technisch Bureau Muller, Amsterdam, The Netherlands, Tel: 31 20 868110 • ICE, 6 Youssef Abbaf #908, Nasr, Cairo, Egypt •

## At a Glance

### Name

Abilityphone

### Manufacturer

Basic Telecommunications Corporation  
4414 East Harmony Rd.  
Fort Collins, CO 80525  
(303) 226-4688 (Voice/TDD option)

### Price

\$2335 (suggested retail price)

### Warranty

Two-year limited on all BTC equipment against defects in material and workmanship

### Shipping size

13½ by 15 by 3¾ inches

### Weight

8½ pounds

### Other physical characteristics

32-character alphanumeric display; 1½-hour battery backup; adjustable-membrane keyboard with 22 keys that responds to as little as 5 ounces' pressure for activation; Lexicon plastic housing; brushed aluminum base panel that accepts 2.5 mm external switch jacks, 3.5 mm audio output jacks, modular phone jack, and modular headset jack

### Software needed

None

### Audience

Anyone interested in devices that assist individuals with disabilities of all types; people with disabilities who have unique telecommunications problems

homes. The Abilityphone, made by Basic Telecommunications Corporation (BTC) in Fort Collins, Colorado, is a prime example of what can be done with a dual-micro-processor-based system, persistence, and some luck.

The luck came in when I was selected as one of ten people to participate in a three-month field testing of the phone in May 1981. My first reaction to the concept of the Abilityphone was that it was too good to be true. But it sounded interesting, and I had learned not to underestimate the potential of electronics. Besides, I was interested in anything that would improve my ability to communicate.

## Workshop for "Test Pilots"

BTC invited me to a workshop designed to familiarize the "test pilots" with the new telecommunications device. We learned that the Abilityphone can answer itself automatically, dial and redial a number by itself, and function as an alarm clock, a four-function calculator, an environmental controller, and a calendar. It can even remind its user to take daily doses of medication. The terminal includes more than 40 features.

Some time after the workshop, I learned that this phone was the result of a six-month market-research study done in 1974 by BTC corporation president Tom Cannon, then a human-factors and product-development consultant. The study, designed to determine the special telephone needs of people with disabilities, concluded that there was a "significant" need for special telephone devices. According to Cannon, the study was not intended to result in a specific product but to identify specific telephone problems of people with disabilities.

What happened next reminded me of something from a science-fiction movie. The 13½-by-15-inch Lexicon plastic phone said "Help on" in a clear and computer-generated voice to confirm that the Help function had been activated. Then it calmly (at least one of the three of us was calm) said, "I am calling for help now: calling help number one."

As it spoke, a 32-character alphanumeric display flashed the messages so that if I had been deaf I would have been able to understand what it was doing. Next, I heard my personal-service aide's phone ringing through the speaker (the Abilityphone does not have a conventional receiver). When my aide, who lives in an adjoining dorm, picked up her phone, my phone again spoke in its electronic voice: "There is an emergency at 8117 Selleck . . . forced entry is authorized."

My aide had a Help-Answer beeper, which sent a message to the Abilityphone terminal that help was on the way. The phone, in turn, flashed a message to that effect on its display. Had my aide failed to answer the phone within five rings, the Abilityphone would have called another help number until it heard the beeper.

When the crisis was over, I marveled at how far the art of computer technology has progressed in helping people with disabilities to live outside institutions or nursing

## Developing the Abilityphone

In 1974, four major obstacles stood in the way of developing a special telecommunications product. Most important, the technology to solve problems raised by the study wasn't available. Even if it had been, the people who could benefit most from it were the most difficult to reach because of social service agencies' privacy-protection policies. Additionally, those who needed the product often could not pay for it, and third-party sources of money, such as insurance companies, were reluctant to assist paying for it. Finally, the product would have had to be sold through existing phone companies, which then did not have the experience to deal with the unique needs of people with disabilities.

But between 1974 and 1978, many changes had taken place that made designing a special device for individuals practicable. New technologies, such as microcomputers, were available at a reasonable cost to provide solutions to many problems. New laws and regulations made equal opportunities for those with disabilities a reality, not just a dream, and people with disabilities were demanding to be treated as equals. In addition, government deregulation of the telephone industry opened the field for companies to sell new products to be hooked up to telephone lines.



# THE ANN ARBOR AMBASSADOR™ 300

## WHY SETTLE FOR AN EMULATION?



*When you  
can have more  
than twice the display lines  
with an **AMBASSADOR 300!***

- 60 line (4800 character) display
- Large 15-inch non-glare screen
- Line drawing character set
- Area qualifications: protect, guard, numerics, justify and security
- Operator convenience modes
- Erase and editing controls
- Supports DEC\*VT52\*/ANSI Mode, Origin Mode and scrolling regions
- Printer output: local and remote copy, print format control
- Block and character transmission
- 48 programmable function keys
- Self diagnostics

Now you don't have to give up a full page display to use your VT100\*-oriented software. The Ann Arbor Ambassador 300 has all the features of the standard Ambassador—with a few modes added to make it easy to use with DEC\* software. You'll also find ways to use the other advanced capabilities of the Ambassador—editing, formatting, programmable function keys, block transmission. So why buy just another emulation when you can get the Ambassador 300? At a competitive price, with quick delivery.

**Call Ann Arbor Terminals for more information at (313) 663-8000**

\*DEC, VT100 and VT52 are trademarks of Digital Equipment Corporation.



6175 JACKSON ROAD • ANN ARBOR, MICHIGAN 48103 • TEL: 313-663-8000 • TWX 810-223-6033

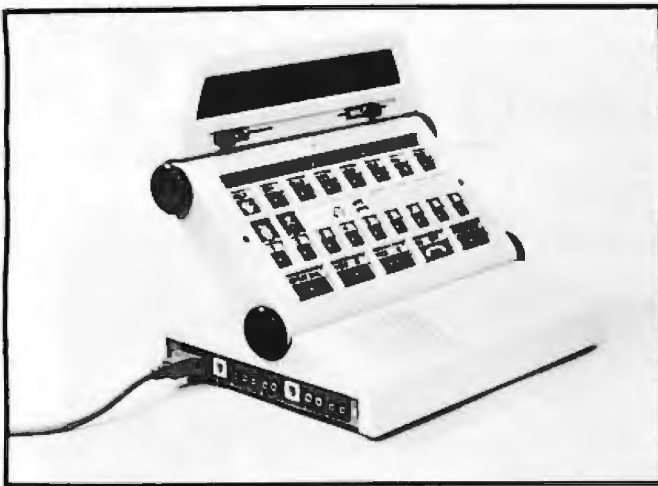

**Photo 2: The Abilityphone.** Note that the keyboard and display sections can be tilted at any angle. The membrane keyboard adjusts to respond to as little as five ounces of pressure. A fluorescent alphanumeric display of 32 characters is standard.

These developments encouraged Tom Cannon to recommend that BTC develop a simulator that would allow the corporation to test its ideas for solving the telecommunication problems of disabled individuals. Such a simulator incorporated a home computer, and people with various disabilities were asked to test the simulator for three months. Another version of the simulator was portable and consisted of a computer in a suitcase, which

took 18 months and about 6000 man-hours to build and test. BTC took the suitcase simulator to rehabilitation and independent living centers across the country to get more feedback.

The goal of the simulators' designers was to build a product that would serve people with all types of disabilities so that it could be mass produced and, as a result, more affordable.

### The Finished Product

In March 1981, at the American Occupational Therapy Conference in San Antonio, Texas, BTC unveiled the result of more than three years and 24,000 man-hours of work. In the five months that followed, BTC went into full-scale production. During this time, the Abilityphone underwent a battery of tests by an independent testing laboratory that made sure it met a wide variety of governmental and other standards.

The Abilityphone uses two microprocessors. The main one is an RCA 1802. The terminal contains 24K bytes of ROM (read-only memory) and 4K bytes of RAM (random-access read/write memory). In addition, all I/O (input/output) devices are memory-mapped. The RAM, ROM, and I/O all reside in the lower 32K bytes of the processor's address space.

The second microprocessor is an Intel 8048 with on-chip RAM and ROM. It is a peripheral processor that monitors the phone line and performs the environmental control functions (the unit will send commands to any BSR remote-control module). The terminal uses prioritized interrupts. The main processor and peripheral processor are set up in a master-slave arrangement. When the master sends a command to the slave, it causes an interrupt to occur on the slave. When the slave has finished its task, it sends a status message back to the master.

The Abilityphone's I/O devices include a membrane-style keyboard (see photo 2), but it doesn't have a full alphanumeric or typewriter keyboard. It uses a fluorescent alphanumeric display that is readable at about 20 feet. It has a serial port and a modem. A speech synthesizer, also included, has a limited vocabulary and is not a true phonetic synthesizer. More memory can be added to increase the unit's vocabulary. Figure 1 shows a block diagram of the Abilityphone.

BTC does a thorough "burn-in" on every terminal to check for faulty components. Testing takes from six to eight hours.

### Features

The following is a selective list of some of the Abilityphone's features.

**Emergency dialing.** The Abilityphone will dial up to six predetermined phone numbers in sequence when the user pushes the Help key. Depending on the options selected on the terminal, the Help message can be either spoken or transmitted as data. The party called can respond with a Help-Answer beeper.

**Monitoring.** At predetermined times, the Abilityphone can ask, "Are you OK?" If the user doesn't respond with-

From Computer Plus to YOU...

## PLUS after PLUS after PLUS

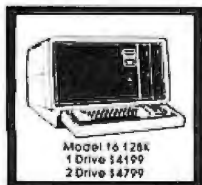

Model 16 128K  
1 Drive \$4199  
2 Drive 14799



Color Computer 16K 1305  
w/16K Ext. Basic 1399  
w/32K Ext. Basic 1499

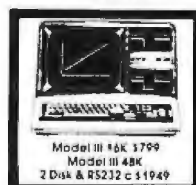

Model III 16K 1799  
Model III 48K  
2 Disk & RS232 c \$1949



Okidata 82A 1425

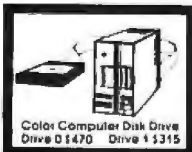

Color Computer Disk Drive  
Drive D 1470 Drive 1 1315



Smith Corona TPI  
Daisy Wheel \$599

**BUY DIRECT** Here are just a few of our line offers... call TOLL FREE for full information.

COMPUTERS	MODEMS	PRINTERS	DISK DRIVES
Model II 64K 53100	Model 16 2DR 128K 4799	R.S. Model III 151-Drive 679	R.S. Model III 151-Drive 289
Model II 4K (LEV) 599	DI-1 Data Terminal 599	8-Double Density Double Sided Drives 49 95	Color Computer Drive 1 315
MODEL III 16K 799	Lynx Direct Connect MCM III 235	CI-80A recorder 32	Color Computer Drive 0 470
MODEL III 32K 856 50	Hayes Smart Modem II 235	C. C. Joystick 22	Color Computer Files D.O.S. 75
*MODEL III 32K 831 50	Telephone Interface II 169	16K RAM N.E.C. 200 N.S. chips 25	R.S. Software 10% off list 99
MODEL III 48K 914	R.S. Modem I D.C. 130	64K Ram Chips 75	
MODEL III 48K 864	R.S. Modem II D.C. 210	Color Computer Files D.O.S. 99	
Model III 48K 1949	PRINTER	ETC.	
2 Disk & RS232 c 1949	Daisy Wheel II 1715	Verbatim 5 Double Density 32	
Model III 48K 1749	Smith Corona TPI Daisy Wheel 599	8-Double Density Double Sided Drives 49 95	
Color Computer 16K 305	Epson MX80 549	CI-80A recorder 32	
Color Computer 16K 305	Epson MX80 FT 549	C. C. Joystick 22	
w/extended basic 399	Epson MX100 735	16K RAM N.E.C. 200 N.S. chips 25	
Color Computer 32K 409	Line Printer VII 249	64K Ram Chips 75	
w/extended basic 409	Line Printer VIII 599	Color Computer Files D.O.S. 99	
Color Computer 32K-64K 510	Line Printer V 1610		
w/extended basic 510	Microline 80 325		
Pocket Computer 2 230	Microline 82A 425		
Model 16 1DR 128K 4199	Microline 83A 699		
	Microline 84 Parallel 1090		
	P. C. Plotter Printer 109		

We have the lowest possible Fully Warranted Prices AND a full complement of Radio Shack Software.

Prices subject to change without notice. Not responsible for typographical errors. RS 80 is a registered trademark of Tandy Corp.



**computer plus**

480 King Street  
Littleton, MA 01460  
617-485-3193

Write for your free catalog

# IMAGINE IT...

**NOW WITH  
DUAL HI-RES  
GRAPHICS**

**NEW**



## CAPTURE IT

### Completely Redesigned. Now, the Grappler+.

The original Grappler was the first graphics interface to give you hi-res screen dumps from your keyboard. The new Grappler+ with *Dual Hi-Res Graphics* adds flexibility with a side-by-side printout of page 1 and page 2 graphics.

Interfacing the Grappler+ to a wide range of printers is easy as changing a dip switch. 4K of exclusive firmware makes the Grappler+ the most intelligent, full-featured Apple® Printer Interface made. And, the Grappler+ is Apple III compatible.\*

The imitations are many, so insist on the #1 Apple Graphics Interface on the market. Insist on the Grappler+. Available now at most Apple dealers.



ACTUAL APPLE II PRINTOUT USING GRAPPLER+ AND EPSON MX100

## With The Grappler+ Printer Interface

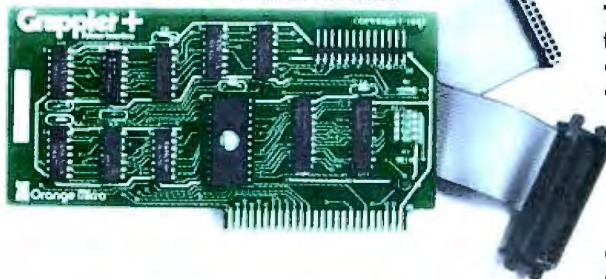

### The Grappler+ Features:

- Dual Hi-Res Graphics • Printer Selector Dip Switch • Apple III Compatible\* • Graphics Screen Dump • Inverse Graphics • Emphasized Graphics • Double Size Picture • 90° Rotation • Center Graphics • Chart Recorder Mode • Block Graphics • Bell Control • Skip-over-perf • Left and Right Margins • Variable Line Length • Text Screen Dumps.

The Grappler+ works with Pascal and CPM.

### The Grappler+ Interfaces with the following printers:

- Anadex • Centronics • Datasouth • Epson\*\* • IDS • NEC • C-Itoh • Okidata\*\*

**Orange Micro**  
inc.

3150 E. La Palma, Suite G  
Anahelm, California 92806  
(714) 630-3620

CPM is a registered trademark of Digital Research, Inc.  
Apple is a registered trademark of Apple Computer, Inc.  
Foreign Dealer Inquiries Welcome TX163511 CSMA

\*Requires additional software driver.

\*\*Requires graphics upgrade.

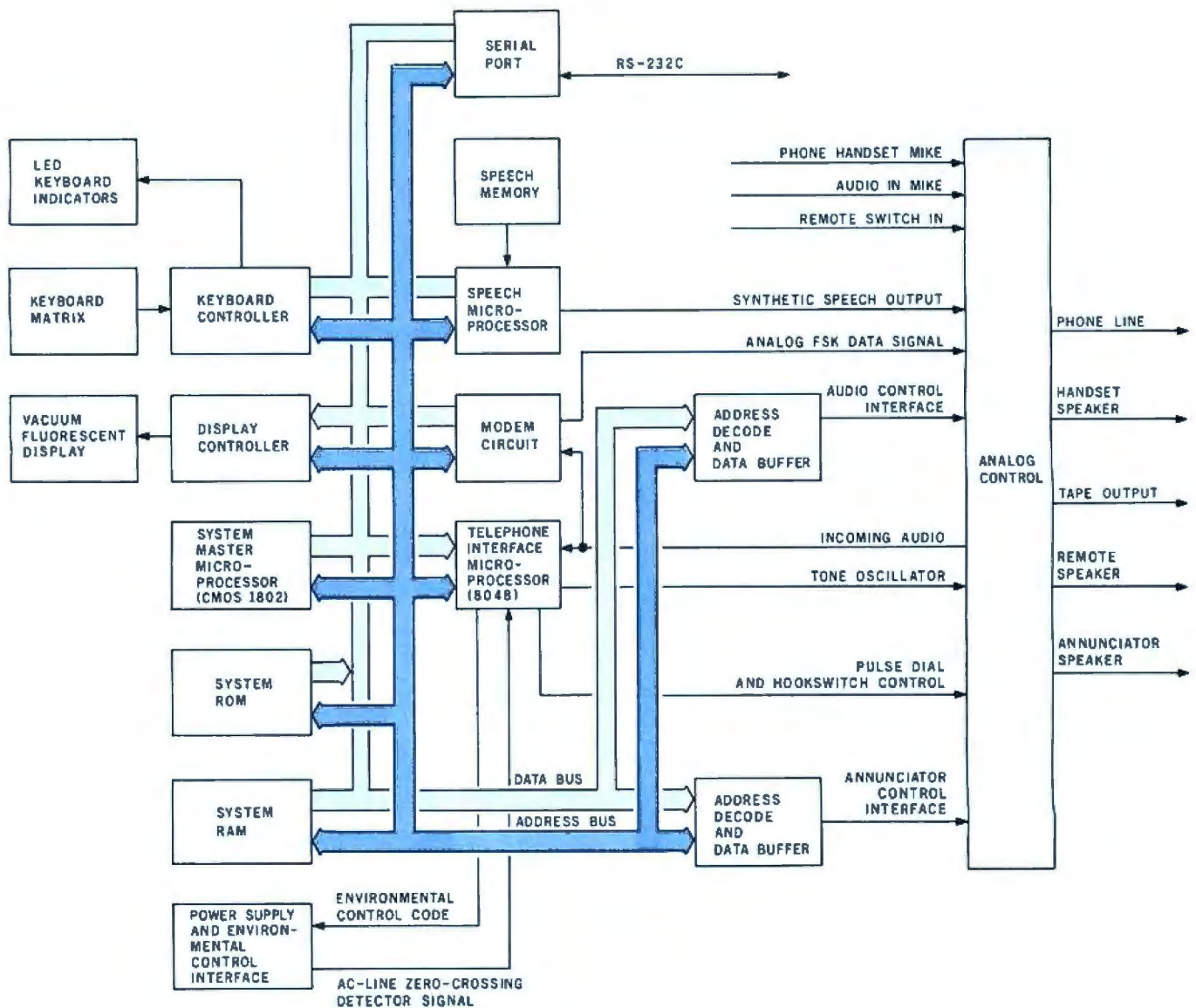

Figure 1: A block diagram of the Abilityphone.

in five minutes, the Abilityphone dials an emergency number. This assures the user that help will be summoned even if he or she can't get to the phone.

**Reminding.** The Abilityphone can be set to remind the user at predetermined times to perform routine tasks that are necessary to prevent a crisis. This function is ideal for providing prompts to take medicine, eat special meals, or change position to avoid pressure sores.

**Automatic answering.** After three rings, the Abilityphone will answer itself, allowing the user with limited mobility additional time to get to the phone.

**Repeat dialing.** When a dialed number is busy or the party called fails to answer, the Abilityphone will redial the number until the party is reached.

## Conclusion

You might wonder if all the time and effort that goes into building such equipment is worth the benefits to its

users and to society. I can't answer the question for society. I can only hope society sees that through the use of such equipment, it will gain more productive members.

As a user, however, I can attest to the Abilityphone as invaluable. Of all my electronic devices (electric wheelchair, door opener, and computerized voice synthesizer), the Abilityphone makes me feel most secure. One of its 40-odd features, a monitoring function, is a good example. I can set it so that, at predetermined times, the terminal can ask me, "Are you OK?" Then if neither I nor an aide presses one of its 22 keys within 5 minutes, the phone will call for help on its own.

I used to panic when my morning personal-service aide was 15 minutes late to get me out of bed. Now when that happens, I wait serenely to hear the phone say, "Are you OK?" And if nobody answers its musical ring within five minutes, it announces, "I am calling for help now. . . ." ■

# Interested in the IBM Personal Computer?

**I**f you're interested in the IBM Personal Computer then you need PC magazine. PC magazine is the Independent Guide to IBM Personal Computers. Each issue is packed with information for everyone interested in IBM Personal Computers.

PC magazine tells you how to put together the best IBM "PC" system and then how to get the most out of it. Each issue brings you hundreds of colorful pages of evaluations, insights, and straight talk from respected experts—professionals in computer science as well as writers, businessmen, lawyers, educators, and many others.

PC covers software, hardware, applications and most every topic of importance to the thousands of IBM Personal Computer users who read it. To ensure that we give you the information you need, PC includes a special "User-to-User" section, as well as a "PC Wish List", and news about IBM Personal



now. If not fully satisfied when you receive your first copy of PC, simply return your mailing label within 15 days for a full refund.

**This is the  
magazine  
that tells you  
all about it.**

Computer clubs, events and publications.

For a limited time, you can subscribe to PC at NO RISK and still receive a 25% discount off the newsstand price. Enter your subscription

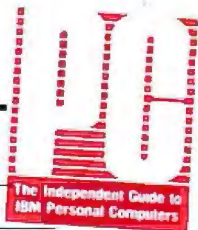

Name \_\_\_\_\_

Address \_\_\_\_\_

City \_\_\_\_\_ State \_\_\_\_\_ Zip \_\_\_\_\_

6 issues/\$14.50     12 issues/\$27.00     24 issues/\$46.00

Check enclosed     VISA     MasterCard     Bill me

Card #                 expires \_\_\_\_\_

I already own an IBM "PC"     I am thinking about buying one

**Dept. B9,**  
PC Magazine  
1528 Irving St.,  
S.F., CA 94122

**Phone Credit Card Orders to:**  
(Toll Free Number)  
California: 800/792-0990, ext. 1136  
All Other States: 800/227-3800, ext. 1136

BYTE 9

# Better Writing-

Introducing the first affordable

# THE RANDOM HOUSE ELECTRONIC THESAURUS

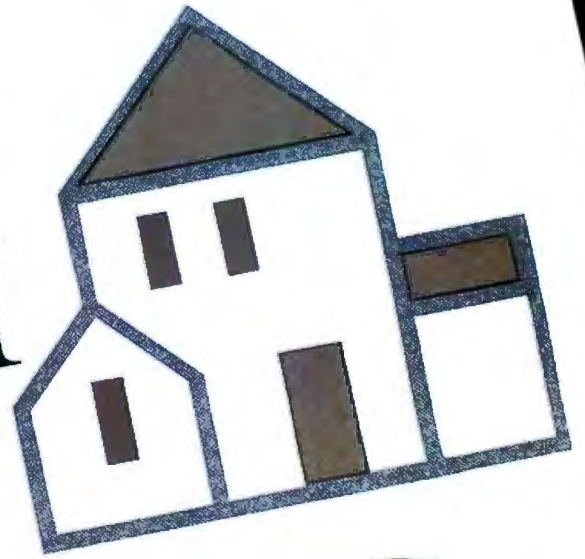

*from Dictronic Publishing Inc.*

Circle 158 on Inquiry card.

Random House and the House design are registered trademarks of Random House Inc. The Random House Electronic Thesaurus is a trademark of Random House Inc. Dictronic Publishing Inc. exclusive licensee. WordStar is a registered trademark of MicroPro International Corporation. CP/M registered trademark of Digital Research, Inc. PatchTest and Magic Wand are trademarks of Peachtree Software Incorporated. an MSA company. Osbourne is a product of the Osbourne Computer Corporation. Script is a trademark of Tandy Corporation. EasyWriter is a trademark of Informal Unlimited Software, Inc. IBM is registered trademark of International Business Machines Corp. Copyright © 1982 Dictronic Publishing

# Fast!

## Thesaurus software

Good writing is hard writing. And finding just the right words is the hardest part. You could use a thesaurus—but who wants to wrestle with a five pound book? So you go with what comes to mind. And your writing suffers.

No more! Thanks to the Random House Electronic Thesaurus™. As these actual photos at right show, you can now have instant, on-screen access to more than 60,000 synonyms indexed to the 4,700 most used and overused words in English. Without exiting your word processing program. Without waiting more than two seconds, on average. Without giant hard disks. Without complex directions. And your selections are automatically inserted into the text.

The Random House Electronic Thesaurus™ fits all systems: The 60,000 synonym version requires 240K. Abridged versions are available in 80k and 150k sizes. You can update to a larger size for just \$25. The software is totally compatible with WordStar™ 2.6, 3.0 and later. Or use it directly from CP/M™.

It comes in all popular system formats, by mail from Dictronic or from your local dealer. Peachtext™ (Magic Wand™) users can buy it from Peachtree vendors or directly from Peachtree Software. This fall, look for Osborne\*, Scripsit™, EasyWriter™ and WordStar-IBM™ versions.

The Random House Electronic Thesaurus is based on the popular Random House Thesaurus, edited and backed by one of the most respected names in publishing. It will change the way you feel about writing. The price is right, too—only \$150.

And we'll even throw in the book.

For information and orders, please call  
Dictronic Customer Service at

**505-281-5444.**

Master Charge and Visa Accepted  
Or complete coupon and write

Dictronic

PO Box 367, Tijeras, NM 87059

ENCLOSED IS \$150 RUSH ME

THE RANDOM HOUSE

ELECTRONIC THESAURUS

SEND ME INFORMATION RIGHT AWAY

Name

Title

Company

Street

City

State  Zip

Computer Manufacturer

Operating System  Disk Size

Dealer Inquiries Invited—please call  
Dictronic Business Office at 212-564-0746



**1** To find a synonym, simply position your cursor on the desired word. Or just type the word.

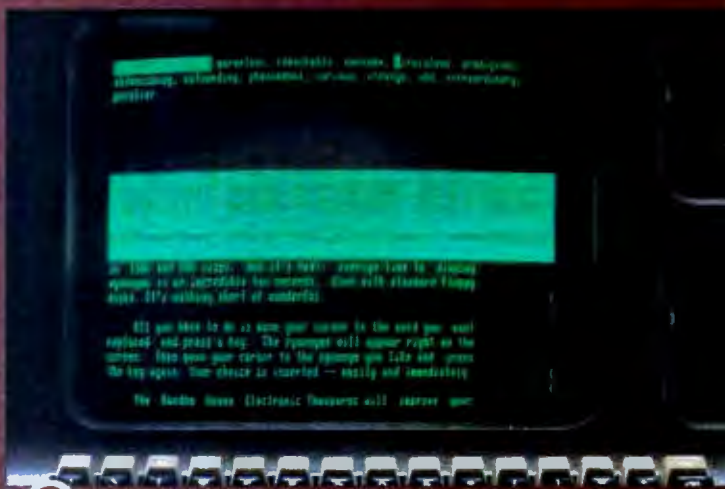

**2** When you press **ESCAPE** twice—or a special key in custom installations, the top of the screen clears and fills with up to 100 synonyms. When you find a suitable synonym, bring your cursor to it and press **ESCAPE** again.

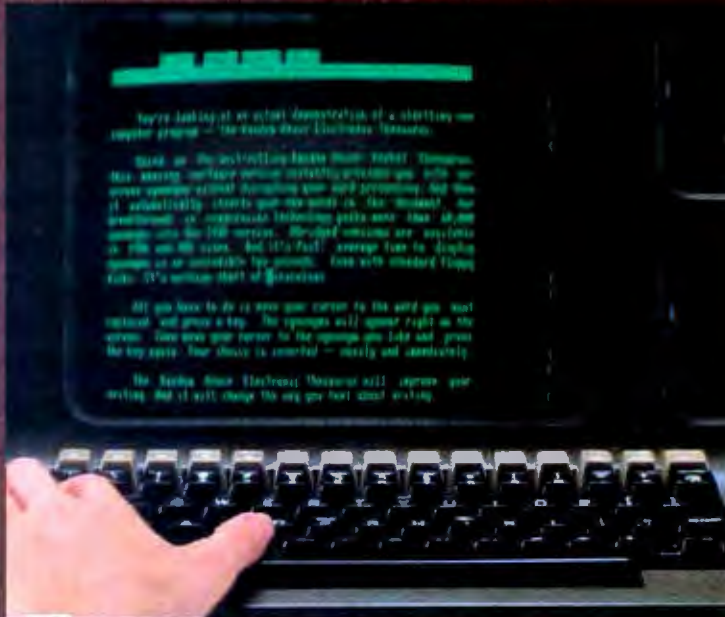

**3** Your old word is deleted and the synonym is automatically inserted. Or you can press **RETURN** and return to your text without making any changes. You can even scroll through the listings.



(BYTE Magazine written in braille)

# Braille Writing in Pascal

*A Pascal program, a strip of cellophane tape, and a rubber glove combine to make a line printer write in braille.*

---

Alfred Fant Jr.  
POB 26284  
Austin, TX 78755-0284

---

Braille writing for the blind was developed by the Frenchman Louis Braille, who was himself blinded at the age of three. Since the invention of his language in 1824, thousands of books, magazines, musical scores, and other literary works have been translated into braille. One of the most ambitious translation projects to date has been the braille edition of the *World Book Encyclopedia* by the American Printing House for the Blind in 1961. The largest project in the history of braille, it will probably be the last time such a large undertaking is done by hand. The final edition of the encyclopedia contained 136 volumes—truly, a magnificent accomplishment.

Today, numerous publications are translated into this readable print for the blind. Still, it is not unusual for a book on the best-seller list to be re-

maindered before it is finally brailled. This happens because there is much more material to braille than there is funding to do it. Blind people (and libraries serving the blind) are queried

---

**The software treats the braille characters as four lines of graphics output per line of braille type.**

---

periodically as to what publications they would like to see brailled next and to rank them by priority. The limited funds and computer time available make it mandatory to translate only those publications that would have the greatest readership.

Hence, in a situation similar to military triage, many worthwhile books are never translated.

My interest in braille translation began when a local Boy Scout troop asked for help in acquiring scouting materials for its new blind members. A survey of the literature found much in the way of audio-tape materials. Unfortunately, precious little material was in braille. The Scouts had found it difficult to use the tape library because they could not readily locate specific topics. You just cannot skim a tape as you can a printed braille book.

I proceeded to learn braille from the instructions given in the Scout Handbook, soon progressed to a college textbook on the subject, and finally purchased a braille machine to use with the visually disabled boys. After months of practice, study, and



# For serious business microcomputing, only one operating system exactly fits.

Whether you're in business and do microcomputing, or in computing and sell to business, you'll like OASIS.\* Not a hobby or scientific system warmed-over for business use, OASIS is the only operating system designed from the ground up for business.

## SERIOUS BUSINESS COMES IN ALL SIZES.

Whatever your business need, OASIS has the operating system to match: 8-bit or 16-, single-user or the multi-user system that professionals tell us makes micros run like minis. And that's even truer now with new OASIS-16.\*\* (OASIS exact business fit #1: choice.)

## ANY SYSTEM IS ONLY AS GOOD AS THE BUSINESS PROGRAMS IT RUNS.

The acid test for any business operating system is the application software available to run on it. There's plenty for OASIS—for nearly any job.

And it's top quality, too, because our integrated tools are top quality—and there are more of them. Like a high-level BASIC Interpreter/Compiler/Editor/Debugger; ISAM/Keyed/Direct/Sequential Files; a smart Print Spooler; Automatic Record Locking (OASIS exclusives!); plus COBOL & 'C' Languages. These tools are mandatory for high-quality business application program development—ask any developer. (OASIS exact business fit #2: high-quality application software.)

## PORTABILITY PROTECTS BUSINESS SOFTWARE INVESTMENTS.

OASIS is custom-fitted to manufacturers' hardware so application software developed to run on one OASIS equipped machine can also run on others—and is upwardly compatible from 8-bit OASIS Single-User to Multi-User, on up to OASIS-16. This kind of application software portability is exclusive with OASIS.

Device independence allows various printers and terminals to be used—with no modification to application

software: OASIS system software compensates for differences. (OASIS exact business fit #3: portability.)

## ACCURATE DATA & A SECURE SYSTEM REDUCE BUSINESS RISKS.

Data integrity—a challenge for any multi-user system—is insured by OASIS File & Automatic Record Locking. With it, normally all users can view a record at the same time. BUT, if the record is being updated by one user, other users are automatically denied access until the update is complete. That means data is always accurate and up-to-date. And it's still another OASIS exclusive.

For system security, there's OASIS Logon, Password & Privilege Level. User Accounting keeps track of who used the system, when. (OASIS exact business fit #4: data integrity/system security.)

## A FRIENDLY SYSTEM IS GOOD BUSINESS.

For user-friendliness, OASIS sets new standards. Example: the EXEC Job Control Language is so smart it walks users through their applications—and around the operating system.

With our 'HELP' feature, if you are unsure of the functions and options

available, type 'HELP' and the command function title—OASIS displays the syntax and options available.

And it's all in your language—not computerese. (OASIS exact business fit #5: user-friendliness.)

## AND, AND, AND...

Some of the best, most extensive documentation in the industry; a packed Application Software Directory; multi-level training; direct telephone support; worldwide sales & service; options like CONTROL Relational Data Base Management System and MASTERPLAN Financial Modeling Package; OASIS has it all. (OASIS exact business fits #6 through #12.)

Now you know why there's no reason to struggle trying to put a square peg in a round hole. For serious business microcomputing,

there is one operating system that exactly fits: OASIS. Call or write us today for details.

\* For Z80

\*\* For 8086 58000 Z8000 LSI-11 & others

# OASIS

STRICTLY BUSINESS

## PHASE ONE SYSTEMS, INC.

7700 Edgewater Drive, Suite 830  
Oakland, CA 94621-3051  
Telephone 415/562-8085 TWX 910-366-7139

I'm serious about my business—  
please send me

OASIS-16 Manual, \$75

OASIS Manual, \$60

Free Application Software Directory  
and put me on your mailing list

(Add \$3 for shipping. California residents add sales tax.)

Name \_\_\_\_\_

St. (No Box #) \_\_\_\_\_

City \_\_\_\_\_ State \_\_\_\_\_ Zip \_\_\_\_\_

Check enclosed  UPS C.O.D.

VISA  Mastercharge

Card No. \_\_\_\_\_ Exp. date \_\_\_\_\_

Signature \_\_\_\_\_

# NSS Offers An Incredible Advantage.



NSS software, written specifically for Northstar's ADVANTAGE™, outperforms any software available for Northstar computer systems. Our fully integrated accounting package includes general ledger, accounts receivable, accounts payable, inventory control and payroll—  
**the first Northstar payroll package.**

Why NSS software? If you're a Northstar dealer, it means greater ease in closing sales of Northstar's computer systems within vertical markets. Or, if you own a Northstar computer, it means greater flexibility and expanded capability for your Northstar as a business tool.

Our vertical market applications, such as those we have developed for tire dealers, are the best on the market. Let the ADVANTAGE™ talk to you with NSS' unique cassette training tapes, demonstration disks and sales kits. NSS also provides dealer seminars and a toll free support hotline.

## That's The Incredible Advantage!

Order your Introductory  
Dealer Kit NOW

or  
CALL TOLL FREE FOR  
MORE DETAILS

**1-800-722-3446**



NATIONAL SOFTWARE  
SYSTEMS  
P.O. Box 510911  
Salt Lake City, Utah 84151

ADVANTAGE and Northstar are registered  
trademarks of Northstar Computers

hand-braille of various scouting materials, I felt there had to be a faster way to translate our literature. Eventually, the idea of a computer translation came to my mind.

While working on a program to graph multifunctions on a line printer, I devised a software method to allow braille on a standard line printer with no permanent modifications. Basically, the software treats the braille characters as four lines of graphics output per line of braille type. I hasten to add that you have to add a strip of specially prepared cellophane tape to the printer, but it is not necessary to remove the inked ribbon or readjust the printer's impact force. Indeed, regular printer output can be handled concurrently with the braille output.

### The Latex Cushion

The devised modification for the line printer had to be simple, quick, and easily removable. The solution was a 9-inch strip of half-inch-wide, double-stick cellophane tape covering a similarly sized strip of thin latex rubber, which was cut from common household gloves used for dishwashing. The best results were obtained by using so-called flock-lined gloves. Place the latex side of the strip against the cellophane tape, leaving the flock lining exposed. Finally, press this assembly into place on the metal platen behind the computer paper. When the printer head strikes the paper, it will leave an indentation because of the minute additional travel afforded by the flock cushion.

Please note that the double-stick tape must be *completely* covered by the latex strip. This is very important because if any part of the tape is exposed, the computer paper will drag on it and cause paper-feeding jams. Of course, if you have a printer that uses a rubber platen (for example, an IBM Selectric), you would be able to eliminate the latex-tape cushion altogether.

### The Software

The accompanying program (see listing 1) is written in standard, transportable (we can hope) Pascal.

"My Legend memory expansion cards enhance my Apple and are a superb product for the Apple Computer."

I think the cards are mapped appropriately for extra storage.

The software supplied makes the cards useful even for those who can't modify DOS on their own.

I look forward to upcoming products from Legend."

**Steve Wozniak**  
Co-Founder,  
Apple Computer, Inc.

**If Steve Wozniak, Co-Founder of Apple Computer, Inc., thinks this highly of Legend products, we're doing something right.**

**Go to your nearest computer dealer today and find out for yourself about Legend products.**

**The Original Hi-Density RAM Products  
for APPLE II**



**Legend Industries Ltd.**

2220 Scott Lake Road  
Pontiac, MI 48054  
(313) 674-0953 Office  
(313) 674-1340 Modem

Europe: B.I.P.  
25 Rue DuMont-Cenis  
75018 Paris, France  
(1) 264-02-32

\*Apple II is a product of Apple Computer, Inc.

**Chances are,  
you've already purchased  
two-thirds of our digital,  
programmable  
oscilloscope.**



Apple II, Apple II Plus, Disk II and Silentype are trademarks of Apple Computers, Inc. Epson MX-80 is a trademark of Epson America, Inc.

# Now for \$995 you can have the rest.

In a word, the Model 85 aScope™ is a dual channel, DC to 50 MHz, fully programmable, digital memory oscilloscope designed to operate with any Apple II™ or Apple II Plus™ equipped with Disk II™ and display, 48K memory and DOS 3.3.

But don't let aScope's remarkably low price deceive you. Because in about 80 percent of all design or test applications where this sort of instrument would be used, aScope will perform on par with systems in the \$15,000+ category. (Something we feel comfortable saying, having spent a number of years working in research and development for one of the world's leading suppliers of those \$15,000 instruments.)

Still, we recognize it's a somewhat extraordinary promise.



system. But frankly, we suspect you are probably as intrigued as you could be on the basis of one advertisement.

So we'll proceed with a few action recommendations designed to accommodate anyone from the casually curious to the virtually convinced.

First, you should call 800-547-4445. That will provide you with an aScope data sheet and an opportunity to determine whether you'd like to invest \$10 in our comprehensive aScope demonstration disk.

Or simply yield to your initial impulse and order the system, safe in the knowledge that (a) you may use the system for fifteen days, and if not satisfied, return it, and b) NWIS system engineers stand ready to assist you with any questions you may



Single keystroke calls aScope™ operations menu. All sub-menus provide complete prompting

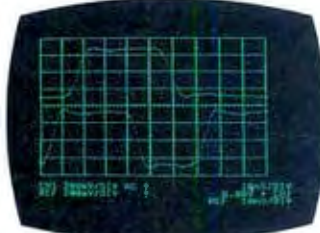

A reference waveform loaded from disk into Channel 2 for comparison with active signal on Channel 1.



Cross-cursor indicates point where aScope™ digital voltmeter (DVM) is calculating waveform voltage for display at bottom of screen



One example of a user-defined co-resident BASIC program: in this case designed to plot an amplitude response curve for an active filter.

So, perhaps before telling you what aScope can do, we ought to tell you how it does it so inexpensively.

Essentially what we've done is depart radically from the existing instrumentation architecture upon which all currently available digital programmable oscilloscope systems are dependent. It simply doesn't make sense to combine a stand-alone

Bandwidth: DC to > 50 MHz equivalent time digitizing (-3dB) DC to > 10 KHz resolvable with real-time digitizing (-3dB)  
 Resolution: 8 bits (1 part in 256)  
 Range: 10ns/division to 20s/division  
 Sensitivity: 5mV/division to 5V/division  
 Input Impedance: 1MΩ and 20pF

programmable oscilloscope with a controller when to a great extent the micro-computer circuitry and capabilities of one are already available in the other. So we didn't combine, we integrated. Making the aScope a peripheral part of the computer. Supplying only what was necessary to make the computer a high-performance instrument. An instrument capable of things until now assumed impossible for

anywhere near its price.

Things like what, you wonder? Well naturally, since aScope is fully programmable you may configure a setup, define the analysis of the acquired data you desire and produce an end result display in whatever form is most productive. Many frequently performed routines are already part of aScope's software. However, because no two engineers' needs are exactly the same, the system's architecture was designed to accommodate considerable user modification via co-resident BASIC or assembly language programs.

In addition, aScope will average waveforms. Store a waveform on disk in binary or text form. Store instrument control settings for future automated setup. Or load and display reference waveforms.

aScope is also equipped to deliver waveform voltage readings utilizing a cursor-controlled digital voltmeter. And to generate hard copies via an Epson MX-80™ or Silentype™ printer.

Space permitting, we could go on about the menu-driven commands and other user-sensitive features we've built into this

have regarding aScope capabilities and applications.

The \$995 Model 85 aScope. We admit the performance it delivers for the money is so remarkable, it may initially strike you as unbelievable. However, when you recall all the breakthrough products this industry has seen over the last decade, sounding unbelievable at first is practically a tradition.



**NORTHWEST INSTRUMENT SYSTEMS, INC.**  
  
 P.O. Box 1309  
 Beaverton, Oregon 97075  
 800-547-4445

Listing 1: BRAILLE, a Pascal program that converts standard English text into standard Form 1 braille.

```

(*****
(*                                     10/21/81                               *)
(* PROGRAMMER: ALFRED FANT, O.A.E.                                         *)
(*                                     *)
(* PROGRAM: BRAILLE                                                         *)
(*                                     *)
(* ABSTRACT:                                                                 *)
(* THIS PROGRAM IS DESIGNED TO PRODUCE "REVERSE" BRAILLE FOR              *)
(* USE WITH AN STANDARD LINE PRINTER. THE BRAILLE CHARACTER ARE          *)
(* REVERSED TO ENABLE TACTILE READING ON THE BACKSIDE OF THE PAPER.      *)
(*                                     *)
(*****

PROGRAM BRAILLE;

CONST P='O'; ( Your printer may give better results with "O" or "@" )

VAR
  CAPITAL,NUMBER,CELL,FORM,I,J:INTEGER;
  CHARACTER:CHAR;
  TA,TB,TC:PACKED ARRAY [1..80] OF CHAR;
  TEST27,TEST27C:PACKED ARRAY [1..30] OF CHAR;

PROCEDURE CONVERT (VAR CHARACTER: CHAR);

BEGIN (*CONVERT*)
  CASE CHARACTER OF
    ' ' : CELL:=CELL+2;
    '" ' : BEGIN TC[CELL+2]:=P; CELL:=CELL+4; END;
    '(' : BEGIN TB[CELL]:=P; TB[CELL+2]:=P;
              TC[CELL]:=P; TC[CELL+2]:=P; CELL:=CELL+4; END;
    ')' : BEGIN TB[CELL]:=P; TB[CELL+2]:=P;
              TC[CELL]:=P; TC[CELL+2]:=P; CELL:=CELL+4; END;
    '///' : BEGIN TC[CELL+2]:=P; CELL:=CELL+4; END;
    '*' : BEGIN TB[CELL]:=P; TB[CELL+2]:=P; CELL:=CELL+4; END;
    '$' : BEGIN TB[CELL]:=P; TB[CELL+2]:=P;
              TC[CELL]:=P; CELL:=CELL+4; END;
    '.' : BEGIN TB[CELL]:=P; TB[CELL+2]:=P;
              TC[CELL]:=P; CELL:=CELL+4; END;
    ',' : BEGIN TB[CELL]:=P; CELL:=CELL+4; END;
    '-' : BEGIN TC[CELL]:=P; TC[CELL+2]:=P; CELL:=CELL+4; END;
    ';' : BEGIN TB[CELL]:=P; TC[CELL]:=P; CELL:=CELL+4; END;
    ':' : BEGIN TB[CELL]:=P; TB[CELL+2]:=P; CELL:=CELL+4; END;
    '?' : BEGIN TB[CELL]:=P;
              TC[CELL]:=P; TC[CELL+2]:=P; CELL:=CELL+4; END;
    '!' : BEGIN TB[CELL]:=P; TB[CELL+2]:=P;
              TC[CELL]:=P; CELL:=CELL+4; END;
    'a' : BEGIN TA[CELL+2]:=P; CELL:=CELL+4; END;
    'b' : BEGIN TA[CELL+2]:=P; TB[CELL+2]:=P; CELL:=CELL+4; END;
    'c' : BEGIN TA[CELL]:=P; TA[CELL+2]:=P; CELL:=CELL+4; END;
    'd' : BEGIN TA[CELL]:=P; TA[CELL+2]:=P;
              TB[CELL]:=P; CELL:=CELL+4; END;
    'e' : BEGIN TA[CELL+2]:=P; TB[CELL]:=P; CELL:=CELL+4; END;
    'f' : BEGIN TA[CELL+2]:=P; TA[CELL]:=P;
              TB[CELL+2]:=P; CELL:=CELL+4; END;
    'g' : BEGIN TA[CELL]:=P; TA[CELL+2]:=P;
              TB[CELL]:=P; TB[CELL+2]:=P; CELL:=CELL+4; END;
    'h' : BEGIN TA[CELL+2]:=P;
              TB[CELL+2]:=P; TB[CELL]:=P; CELL:=CELL+4; END;
    'i' : BEGIN TA[CELL]:=P; TB[CELL+2]:=P; CELL:=CELL+4; END;
    'j' : BEGIN TA[CELL]:=P;
              TB[CELL]:=P; TB[CELL+2]:=P; CELL:=CELL+4; END;
  
```

Listing 1 continued on page 260



# 5000 IS "The Desktop Mainframe"

## The Most Versatile Integrated System Available! — Without Compromise.

From the crystal clear monitor with a true typist keyboard to the high performance switching power supply—an engineered solution—the 5000 IS system is designed with IEEE standard S100 Bus architecture, giving you the flexibility and compatibility expected of an industrial grade computer.

Now you can have 1 MByte Floppies, 25 MByte Winchester with ECC, extended RAM memory (beyond the basic 64K), various peripheral controllers, and best of all, the 5000 IS can serve as

the host processor of a multi-user, multi-processing system. Up to four I/O processors may be resident in the 5000 IS, each with its own Z80 Micro-processor, 64K of memory and two Serial I/O Channels.

With this flexibility you can configure the highest performance, lowest cost multi-processing system available.

Memory parity—of course! Two year warranty—naturally!

For complete information and specifications on the 5000 IS plus the

location of your nearby IMS International dealer, call or write today!  
(714) 978-6966 or (702) 883-7611

**IMS**  
INTERNATIONAL

2800 Lockheed Way  
Carson City, NV 89701  
Telex: 910-385-6051

**We Build Computers As If Your Business  
Depended On Them.**

*See us at Fall COMDEX booth 1144 for more surprises!*

IMS INTERNATIONAL DISTRIBUTORS:	Argentina	Canada	France	India	Korea	Netherlands	So. Africa	Sweden	United Kingdom
	Australia	Chile	Greece	Israel	Malaysia	New Zealand	Singapore	Switzerland	U.S.A.
	Austria	Ecuador	Hong Kong	Italy	Mexico	Philippines	Spain	United Arab Emirates	West Germany



**THE COMMODORE 64. ONLY \$595.**  
What nobody else can give you at twice the price.



# "THE COMMODORE 64 COULD BE THE MICROCOMPUTER INDUSTRY'S OUTSTANDING NEW PRODUCT INTRODUCTION SINCE THE BIRTH OF THIS INDUSTRY."

—SHEARSON/AMERICAN EXPRESS

They're speaking to a group as interested as anyone else in the future of computers: the people who buy stock in the companies that make computers.

If, on the other hand, you're a person whose livelihood depends on a personal computer—or whose leisure time revolves around one—what follows should impress you even more than it impresses investors.

## MIGHT MAKES RIGHT.

The value of a computer is determined by what it can do. What it can do is largely determined by its memory.

The Commodore 64's basic RAM is 64K. This amount of power is unusual enough in a micro at any price.

At \$595, it is astonishing.

Compared with the Apple II+, for instance, the Commodore 64 offers 33% more power at considerably less than 50% of the cost.

Compared with anything else, it's even more impressive.

## PILE ON THE PERIPHERALS.

Because the basic cost of the 64 is so low, you can afford to buy more peripherals for it. Like disk drives, printers, and a telephone modem that's priced at around \$100.

This means you can own the 64, disk drive, printer and modem for a little more than an Apple II+ computer alone.

## HARD FACTS ABOUT SOFTWARE.

The Commodore 64 will have a broad range of custom software packages including an electronic spreadsheet; business graphics (including printout); a user-definable diary/calendar; word processing; mailing lists, and more.

With BASIC as its primary language, it is also PET BASIC compatible.

The Commodore 64 will also be programmable in USCD PASCAL, PILOT and LOGO.

And, with the added CP/M® option, you

will have access to hundreds of exciting software packages.

## THE FUN SIDE OF POWER.

The Commodore 64 can become very playful at a moment's notice.

You can use Commodore's plug-in game cartridges or invent your own diversions. All will be enhanced by brilliant video quality (320 x 200 pixels, 16 available colors, 3D Sprite graphics), plus outstanding sound.

The 64's built-in music synthesizer has a programmable ADSR (attack, decay, sustain, release) envelope, 3 voices (each with a 9-octave range) and 4 waveforms. All of which you can hear through your audio system and see in full color as you compose or play back.

## NOW'S YOUR CHANCE.

If you've been waiting for the "computer revolution," consider it as having arrived.

Through its 25 years of existence, Commodore has been committed to delivering better products at lower prices.

Today, the company's vertical integration has resulted in the Commodore 64's price performance breakthrough heralded by Shearson/American Express.

Visit a Commodore Computer dealer and discover the 64 soon.

It will expand your mind without deflating your wallet.

CP/M® is a registered trademark of Digital Research, Inc.

Commodore Business Machines/Personal Systems Division  
P.O. Box 500 Conshohocken, Pennsylvania 19428

Please send me more information on the Commodore 64.

Name \_\_\_\_\_

Address \_\_\_\_\_

City \_\_\_\_\_ State \_\_\_\_\_ Zip \_\_\_\_\_

Phone \_\_\_\_\_

 **commodore**  
COMPUTER

BYS

Listing 1 continued:

```

'k' : BEGIN TA[CELL+2]:=P; TC[CELL+2]:=P; CELL:=CELL+4; END;
'l' : BEGIN TA[CELL+2]:=P; TB[CELL+2]:=P; TC[CELL+2]:=P; CELL:=CELL+4; END;
'm' : BEGIN TA[CELL]:=P; TA[CELL+2]:=P; TC[CELL+2]:=P; CELL:=CELL+4; END;
'n' : BEGIN TA[CELL]:=P; TA[CELL+2]:=P; TC[CELL+2]:=P; TB[CELL]:=P; CELL:=CELL+4; END;
'o' : BEGIN TA[CELL+2]:=P; TB[CELL]:=P; TC[CELL+2]:=P; CELL:=CELL+4; END;
'p' : BEGIN TA[CELL]:=P; TA[CELL+2]:=P; TB[CELL+2]:=P; TC[CELL+2]:=P; CELL:=CELL+4; END;
'q' : BEGIN TA[CELL]:=P; TA[CELL+2]:=P; TB[CELL]:=P; TB[CELL+2]:=P; TC[CELL+2]:=P; CELL:=CELL+4; END;
'r' : BEGIN TA[CELL+2]:=P; TB[CELL]:=P; TB[CELL+2]:=P; TC[CELL+2]:=P; CELL:=CELL+4; END;
's' : BEGIN TA[CELL]:=P; TB[CELL+2]:=P; TC[CELL+2]:=P; CELL:=CELL+4; END;
't' : BEGIN TA[CELL]:=P; TB[CELL]:=P; TB[CELL+2]:=P; TC[CELL+2]:=P; CELL:=CELL+4; END;
'u' : BEGIN TA[CELL+2]:=P; TC[CELL]:=P; TC[CELL+2]:=P; CELL:=CELL+4; END;
'v' : BEGIN TA[CELL+2]:=P; TB[CELL+2]:=P; TC[CELL+2]:=P; TC[CELL]:=P; CELL:=CELL+4; END;
'w' : BEGIN TA[CELL]:=P; TB[CELL]:=P; TB[CELL+2]:=P; TC[CELL]:=P; CELL:=CELL+4; END;
'x' : BEGIN TA[CELL]:=P; TA[CELL+2]:=P; TC[CELL]:=P; TC[CELL+2]:=P; CELL:=CELL+4; END;
'y' : BEGIN TA[CELL]:=P; TA[CELL+2]:=P; TB[CELL]:=P; TC[CELL]:=P; TC[CELL+2]:=P; CELL:=CELL+4; END;
'z' : BEGIN TA[CELL]:=P; TB[CELL+2]:=P; TC[CELL+2]:=P; CELL:=CELL+4; END;
      OTHERWISE WRITELN('ERROR- UNPRINTABLE CHARACTER:',CHARACTER);
END; (*CASE*)
END; (*CONVERT*)

```

BEGIN (\*BRAILLE\*)

RESET(INPUT);

REPEAT

FOR I:=1 TO 28 DO BEGIN TEST27C[I]:= ' '; TEST27C[21-I]:= ' '; END;

I:=0;

J:=0;

REPEAT

I:=I+1;

READ (CHARACTER);

TEST27C[I]:=CHARACTER;

IF TEST27C[I]=' ' AND TEST27C[I-1]=' ' THEN I:=I-1;

IF CHARACTER IN ['A'..'Z','0'..'9'] THEN J:=J+1;

UNTIL I+J >= 20 OR (I+J >= 15 AND CHARACTER=' ') OR EOF(INPUT);

(\*\*\*\*\*)

(\* Reverse letter \*)

FOR I:=1 TO 20 DO TEST27C[I]:=TEST27C[21-I];

(\* order to allow \*)

(\* tactile reading\*)

(\*\*\*\*\*)

FOR I:=1 TO 80 DO BEGIN

TA[I]:= ' '; (\* Intialize Braille \*)

TB[I]:= ' '; (\* Print buffer \*)

TC[I]:= ' ';

END;

Listing 1 continued:

```
I:=0;
CELL:=1;
REPEAT
  I:=I+1;
  CAPITAL:=0;      { Flag to indicate capitals }
  NUMBER :=0;     { Flag to indicate numbers  }

                                (* Present Braille Cell *)
CHARACTER:=TEST27[I];          (* Position number      *)

IF CHARACTER IN ['A'..'Z']
  THEN BEGIN
    CAPITAL:=1;
                                (* allows space for capital sign *)
    CHARACTER:=CHR(ORD(CHARACTER)+32); (*Gives lower *)
  END;                          (*case char. *)

IF CHARACTER IN ['0'..'9']
  THEN BEGIN
    NUMBER:=1;
                                (* allows space for number sign *)
    IF CHARACTER='0' THEN CHARACTER:='k'
    ELSE
      CHARACTER:=CHR(ORD(CHARACTER)+48);
  END;

CONVERT (CHARACTER);

IF CAPITAL=1 THEN BEGIN
  TC[CELL]:=P;
  CELL:=CELL+3;
END;

IF NUMBER= 1 THEN BEGIN
  TA[CELL]:=P;
  TB[CELL]:=P;
  TC[CELL]:=P;  TC[CELL+1]:=P;
  CELL:=CELL+3;
END;

UNTIL I=21;

(* DEBUGGING TOOL:  Used to write the English forwards and backwards *)
(* WRITELN(TEST27C, ' ',TEST27); *)

WRITELN;                          (*****
WRITELN(TA);                        (* Used to write the three line Braille cells *)
WRITELN(TB);                        (*****
WRITELN(TC);

UNTIL EOF(INPUT)
END. (*BRAILLE*)
```

Special program functions have been avoided in the interest of disseminating this program as widely as possible.

The listing consists of the main program BRAILLE and the procedure CONVERT. BRAILLE reads a text file character by character until it has 20 letters and/or blanks in its buffer.

This restriction of 20 characters is used because only about that many braille cells will fit on the standard 80-column page. BRAILLE then calls CONVERT to translate each character into its corresponding braille cells. However, since capital letters and numbers require two braille cells for their proper interpretation, there will

not always be exactly 20 braille cells on each output line. The program continues to loop back and forth between the reading and the translating until the end-of-file marker is reached on the text file. The program then terminates. A sample of the program output is shown in listing 2.

Although the reader obviously can-

### 90 Percent Perspiration

*Almost every story has a "story behind the story," and this article is no exception. Just as Thomas Edison tried thousands of materials for his first light bulb filament before finally discovering his wife's cotton thread, I spent many months trying to come up with the right material for the braille printer pad. It wasn't easy.*

*I started with a pair of latex surgical gloves and found them to be too thin. Our blind Scouts, reading transcripts prepared with this material, complained that the braille faded after only a few readings.*

*I therefore tried strips cut from thicker and softer gloves, but the printer then began to jam. No matter how many different materials I tried, nothing seemed to work quite right. The answer had to be there—somewhere.*

*Success finally came with my discovery that flock-lined gloves were available at the Safeway supermarket. The cotton lining of these gloves provided just the right amount of padding for the computer braille idea to work. Thomas Edison would have been proud.*

not "feel" the indentations on the reverse side of listing 2, this output has been used successfully with the blind Boy Scouts. The monthly troop newsletter is now produced in both braille and regular print. As a result of this newsletter, we have found that the best indentations occur on thicker paper. The indentations are good for only about 15 readings by a blind per-

son, after which the braille becomes too faded to allow correct letter identification. Even so, this method is ideal for short-lived publications such as newspapers and correspondence.

You may have noticed that BRAILLE allows at most only four words to be printed per output line. Though Braille does have a hyphen to mark divided words, it is better to

divide as few words as possible. From personal studies of computer dictionaries, I know that five-letter words make up the vast bulk of the English language. Therefore, the program counts characters and looks for a space from the fifteenth to twentieth character (a word break). If a space is found, the line is ended. Otherwise, the line is broken after the twentieth character. Four brailled words may occasionally fit on the line of 20 braille characters, but it is wise to keep a one-word safety margin.

This program produces what is known as Form I or Grade I level braille. In Form II braille, abbreviations are used to increase the number of brailled words per page. These standard braille abbreviations are for often-used words and letter combinations in the English language. This program does not address this question because of memory requirements. On a larger computer, however, it would be easy to program a look-up table for these abbreviations and their braille counterparts. Table 1



## CAN'T MAKE ENDS MEET?

We couldn't either. At least, not until 1978 when we began connecting RS-232 devices to IEEE-488 computers with our family of serial interfaces. Three units available for use with Commodore's PET/CBM, the HP-85, Osborne-1 and others, plus our auto-answer/auto-dial 103 Modem, automatic calling unit (Operator), and data communications software. All with cabinet, one-year warranty, documentation. Priced from \$129-389. Details from Sam Edwards:



Dept. B., 3444 Hancock St., San Diego, CA 92110  
(714) 296-2115 • TWX 910-335-1194  
VISA/MasterCard • Dealer Inquiries Welcome

## MULTI-PROGRAMMER SYSTEM-10

### Features:

- Dedicated keys and large display vocabulary for ease of use.
- I/O - 6 baud rates, 13 formats including Intellec, Textronix and Motorola.
- EPROMs, E<sup>2</sup>PROMs and bipolars.
- Gang option - programs eight at once.
- Remote control option.

**\$1,295**

**PROGRAMS  
OVER 250  
DEVICE TYPES**



### FUNCTIONS:

DISPLAY DEVICE DATA	LOAD DATA	CRC - DEVICE/RAM
EDIT RAM DATA	COMPARE FIELDS	CRC - RAM
DEVICE PROGRAM	FILL MEMORY FIELD	I/O HOST PROMPT
TYPE SELECTION	BLOCK MOVE	DIAGNOSTICS
		and more . . .



COMPUTER SYSTEMS CORP

100 East Linton Blvd., Delray Beach, Fla. 33444 (305) 272-2051

# MICRO-TAX<sup>\*</sup> PRODUCES GREAT RETURNS

## On Your Microcomputer Investment

Up until now, you might have thought that microcomputers weren't powerful enough to handle those returns you send off to your computer service bureau each tax season. Micro-Tax™ and your microcomputer with CP/M\* changes all of that.

With Micro-Tax™ you can save time and have the complete security of total in-house, computerized tax preparation. Nothing ever leaves your office. You won't give up versatility and power either. Micro-Tax™ computes and prints over 30 schedules and forms for multiple clients, even partnership and corporate returns. Micro-Tax™ can also compute depreciation by individual items or groups as well as handling the accelerated cost recovery system. Underpayment penalties, self-employment taxes, minimum and alternative minimum and maximum taxes as well as income averaging are all computed automatically. Plus, each tax season Micro-Tax™ can provide you with an update package quickly.

Micro-Tax™ is friendly. Data entry is organized very much like the sequence you use in manual tax preparation. It's flexible too, because you can jump to a specific form and complete

1982 SCHEDULES AND FORMS INCLUDED			
	Level 1 INDIVIDUAL PACKAGE	Level 2 PROFESSIONAL PACKAGE	Level 3 PARTNERSHIP/ CORPORATE
1040, 1040A	x		
1065, 1120		x	
1120S			x
A, B, C, E, ES.			x
G, SE	x	x	
D, F			x
K, K-1			x
R, RP		x	
1116		x	
2106	x	x	
2119		x	
2210		x	
2220			x
2440		x	
2441	x		
3488		x	x
3903		x	
4137		x	
4582			x
4625		x	x
4626			x
4684		x	x
4726		x	
4797		x	x
4835		x	x
4952			x
4972		x	
5695	x	x	
6251		x	
6252		x	x
6785		x	
ACRS		x	
BATCH		x	
Print			x
Substitute	x	x	x
On IRS			
Forms		x	x
Blank			x
Paper			
Continuous		x	
Preprinted			
Forms			
Trans-	\$195.00	\$1,000	\$1,000
parencies	\$ 50	\$100	\$100
22 state returns covered			
Yearly Updates Available for all 3 levels			

it rather than starting with the 1040. Just choose the function you want on the Micro-Tax™ menu, and follow

the instructions given by the computer.

Micro-Tax™ is your answer to the already high and increasing costs of computer service bureaus. You will be able to enter data at the time of the client interview and produce returns that look exactly like those required by the government, right in your own office. In the batch mode, you can enter data all day and print returns at night. That's productivity, and it leaves you time for more creative approaches to your client's tax problems.

For more information call your local software dealer or call direct.



### MICROCOMPUTER TAXSYSTEMS, INCORPORATED

22458 Ventura Boulevard, Suite E, Woodland Hills, California 91364 (213) 704-7800

\*CP/M is a registered trademark of Digital Research  
\*Micro-Tax is a trademark of Microcomputer Taxsystems, Inc.

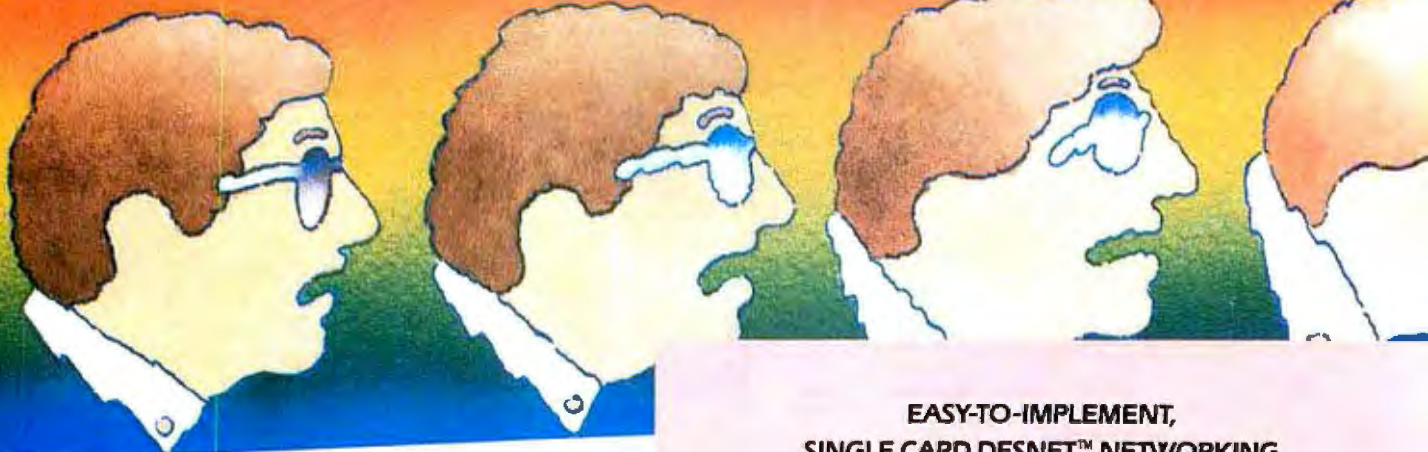

**STOP TALKING  
ABOUT NETWORKING  
AND START TAKING  
ADVANTAGE OF IT.**

**EASY-TO-IMPLEMENT,  
SINGLE CARD DESNET™ NETWORKING  
FOR S-100 BASED SYSTEMS.**

If you design multi-user computer systems, you face a dilemma. You want the system to be powerful. Yet cost-effective. You want each user to have an individual CPU. Yet you can't afford to provide each user with a high-performance printer, hard disk, and modem.

Obviously, you need some way to share system resources. But until now, the alternatives haven't been all that attractive.

**Desnet is the simple, elegant solution.**

A Desnet Network Interface Board in the backplane of each device in your multi-user S-100 system makes shared resources a practical reality. The Desnet common bus topology can network up to 350 devices without sacrificing performance or economy. And with generous maximum cable lengths. Devices can be added, removed, or disabled without affecting the rest of the system.

Not only does the system benefit from the economies of shared resources, it gains capabilities. Like electronic mail, central database access, and on-line telecommunications.

**Low cost, high performance.**

In OEM quantities, Desnet S-100 cards cost less than \$650. Media taps cost under \$50. A similar pair of devices for an Ethernet™ hookup typically costs more than three times as much. For less flexibility.

Desnet network topology is media-independent. You can install a baseband network today, then upgrade to broadband or fiberoptics at any time in the future.



Powerful on-board firmware makes it easy to convert your applications to networked systems. The comprehensive Reference Manual gives you easy, step-by-step instructions.

**Order a starter kit today.**

A Desnet S-100 starter kit gives you everything you need to get a sample network up and running for only \$1,295.

- 2 DESNET S-100 Network Interface Cards
- 2 Baseband Taps
- 20 Feet RG59U Coax Cable
- Applications Demo Disk
- Reference Manual

Pay by major credit card if you wish. To order, call or write The Destek Group, 2111 Landings Drive, Mountain View, CA 94043 (415)968-4610.

**Today, S-100 — tomorrow the world.**

Our S-100 card is just the beginning. Soon Destek will be shipping Desnet cards for Multibus,<sup>™</sup> Q-Bus,<sup>™</sup> Unibus,<sup>™</sup> Versabus,<sup>™</sup> Apple,<sup>®</sup> IBM-PC, and general purpose buses.

So while everyone else is talking about networking, you can be taking advantage of it.

Ethernet is a trademark of Xerox Corp. Multibus is a trademark of Intel Corp. Apple is a trademark of Apple Computer Inc. Desnet is a trademark of The DESTEK Group.



# DESTEK

WE BUILD ACCESS TO PRODUCTIVITY.

**Listing 2:** Sample output from the BRAILLE program, shown in listing 1. This is the first few lines of the Boy Scout troop's newsletter done in braille type. For the convenience of sighted readers, the English words are printed both backward and forward above the braille text. The text is printed in reverse because the blind reader must turn the paper over in order to read the braille cells by touch. The backward English enables the programmer to check for proper letter order. To keep from confusing braille readers, the programmer should "comment out" the English-written line of the final program.

```

September 1981                                     1891 rebmetpeS
      0 0      0 0 0 0      0 0      0 0 0      0 0      0 0      0 0
      0 0 0 0      0 0      0      0 0 0      0      0 0 0      0 0      0
      00      00      00      00      0      0      0      0      0 0
EVOLVE Troop                                     foort EKOVE
      0 0      0 0      0 0 0      0      0      0      0      0
      0 0      0 0 0 0      0      0      0      0      0
      0 0      0 0      0 0 0      0      0 0 0      0 0 0 0      0
23 Newsletter                                     rettelweN 32
      0 0 0      0      0 0 0      0      0 0 0      0 0 0      0 0
      0 0 0      0 0 0 0 0      0      0 0 0 0      0      0      0 0
      0      0 0      0      0 0 0      0 0      0 0      0 0
We want to welcome                               emoclew ot tnaw eW
      0 0 0      0 0 0      0 0 0      0 0 0      0 0 0      0 0
      0      0      0 0 0 0      0 0 0      0 0 0      0 0 0      0 0
      0 0      0      0 0      0 0      0 0      0 0      0 0 0
back Craie Fowler                               relwoF giarC kcab
      0 0      0 0      0 0 0      0 0 0 0      0 0 0 0      0 0 0      0 0
      0 0 0      0 0 0 0      0      0 0 0      0 0      0 0 0      0 0
      0      0 0      0      0      0      0      0
, Dell Garner,                                  ,rennaG lleD ,
      0      0 0 0 0      0 0 0 0      0 0 0 0 0
      0 0 0 0      0 0 0      0 0      0 0 0 0      0      0
      0      0 0      0 0      0      0 0      0 0
Matthew Jackson,                               ,noskcaJ wehttaM
      0 0      0 0      0 0 0      0 0      0      0 0 0 0      0 0 0
      0 0 0      0      0 0 0      0 0      0 0 0 0      0 0 0 0 0 0
      0 0 0 0      0      0      0      0 0      0 0      0 0
Bobby Wright,                                  ,theirW ybboB
      0      0 0 0 0 0      0 0      0 0 0      0 0 0      0
      0 0 0 0 0 0      0 0 0 0 0      0 0 0 0 0      0 0 0 0
and their friends                               sdneirf rieht dna
      0 0 0 0 0      0 0      0 0 0      0 0      0 0 0      0 0 0 0      0
      0 0 0      0      0 0 0 0      0 0 0      0 0 0 0      0 0
      0      0      0      0      0      0      0
from TSB. Their                                 rieht .BST morf
      0 0      0 0 0      0 0      0 0      0 0      0 0 0      0 0 0 0
      0 0 0 0      0 0 0 0      0 0 0      0 0 0      0 0 0 0      0 0 0 0
      0      0 0      0 0      0 0 0      0 0 0      0 0 0      0 0 0
first fall visit                               tisiv llaf tsrif
      0 0 0      0 0      0 0 0      0 0 0      0 0      0 0 0 0
      0 0 0      0 0 0      0 0      0 0 0      0 0 0      0 0
      0      0      0 0      0 0      0      0 0 0
included a tour                                 ruot a dedulcni
      0 0 0 0      0 0 0 0 0 0 0      0 0 0 0 0 0 0
      0 0      0 0 0      0 0 0      0 0      0 0 0      0 0
      0 0 0      0 0      0 0 0      0 0 0      0 0      0

```





# DATAFLEX™

**THE MULTI-USER DATA BASE**

## SOFTWARE FOR CREATORS

Bring your CP/M\* software applications to life with DataFlex. From menus to multi-key ISAM, DataFlex has the features and power you need to create complete turn-key software applications in a RELATIONAL data base environment.

Compare...what else gives you: up to 125 data files with 4 indexes each, fast on-line multi-key ISAM file maintenance, a multi-file report generator, on-line multi-file transaction processing, an easy to use Query, even a "soft" menu to replace the CP/M command mode. All of this using DataFlex's configuration utilities, and NO PROGRAM CODE!

Is it easy to use? You can type in a screen format "image" of a file with your text editor. Then, DataFlex's AUTODEF utility will create the file definition from the screen image...in about five seconds!

DataFlex will handle your multi-user requirements too! It runs under Software 2000's TurboDos Network O/S with data protection to the field level. That means multiple users in the same record at the same time!

If the 16 bit world is your domain, an 8086 version of DataFlex

will be available second quarter '82. And, you can develop now on your 8080/Z-80 system, and transport completed applications to the 8086.

If you need applications now, Data Access has a Library of existing DataFlex applications developed by other creators. They're ready to go at prices that will get you going. The DataFlex Library has Order Entry/Inventory, Accounting, Pharmacy, and Legal Billing, with more being added all the time. For highly specialized requirements, DataFlex's PASCAL Library is available to application developers.

DataFlex can change the way you do business. And, at \$750 it's the best software value in the business. A demo package, which limits file sizes internally, is only \$100 including the manual.

Get the full system, or get the demo, but get your hands on DataFlex.

It's software for creators.

**DATAACCESS®**  
CORPORATION

4221 Ponce De Leon Blvd.,  
Coral Gables, FL 33146  
(305) 446-0669

"Dealer, Systems House and OEM inquiries invited."

\*CP/M is a registered trademark of Digital Research, Pacific Grove, CA.

•    :    ••    •••    ••••    •••••    ••••••    •••••••    ••••••••    •••••••••    ••••••••••

a    b    c    d    e    f    g    h    i    j

The braille alphabet starts by using 10 combinations of the top 4 dots. The same 10 characters, when preceded by a special number sign, are used to express the numbers 1 to 0.

•    :    ••    •••    ••••    •••••    ••••••    •••••••    ••••••••    •••••••••

k    l    m    n    o    p    q    r    s    t

Adding the lower left-hand dot makes the next 10 letters. Adding the lower right-hand dot makes the last 5 letters of the alphabet (except w) and 5 word symbols, below.

••    •••    ••••    •••••    ••••••    •••••••    ••••••••    •••••••••    ••••••••••

u    v    x    y    z    and    for    of    the    with

Omitting the lower left-hand dot forms 9 digraphs, or speech sounds, and the letter w. This construction continues until all possible combinations have been used.

•    :    ••    •••    ••••    •••••    ••••••    •••••••    ••••••••    •••••••••

ch    gh    sh    th    wh    ed    er    ou    ow    w

Table 1: The braille alphabet and some standard braille abbreviations. (Courtesy World Book Encyclopedia)

shows some of these abbreviations and the complete braille alphabet. (See reference 1 for all the standard abbreviations.)

### Conclusion

Braille writing for the blind has been an important contribution of Western civilization. It has brought many blind people into the realm of literature and music. As a programmer, you can now take part in helping the blind to read. Volunteer your computer and time in translating for the blind people in your town. ■

### Further Reading

1. Ashcroft, S.C. and F. Henderson. *Programmed Instruction in Braille*. Pittsburgh: Stanwix House Inc., 1963. (An excellent textbook for the adult who has had no previous knowledge of braille. A "learn to braille in 10 lessons" type of book.)
2. Day, Margaret R. "Tactual Mapping and Nonvisual Perception." Master's thesis, University of Texas at Austin, 1976. (A major work in braille mapping, it covers the history of such special maps and the efforts to make them using computers.)

Computer Channel

## Best Price • Good Quality • Swift Delivery • Export

COMPUTER	PRINTER	SOFTWARE
<p><b>*The Best Graphic Personal Computer*</b></p> <p>LNW 801 Z80A, 85K, 480 x 192 ..... 1,395 w/CPM compatible ..... 1,670 125K, CPM compatible ..... 2,100 RGB interface ..... 125</p> <p><b>*Multituser Business/Engineer*</b></p> <p>CROMEMCO Best Price Anywhere CS1 64K floppy ..... 2,956 ZZH hard disk system ..... 7,398 CS3 84K, 8" ..... 5,177 CS1D2E 256K RAM, 68000 &amp; Z80 2 8" floppy ..... 4,067 C10 64K sp w/12" monitor ..... 950 DYNABYTE 5200 64K, 1MB, Z80A ..... 3,300 5605 64K, 64MB hard d. .... 5,550</p> <p><b>*Professional/Word Process*</b></p> <p>ZENITH Z90-80, 64K ..... 2,050 Z80-B2, 64K, 1 disk ..... 2,350 Z89, 48K, 1 disk ..... 2,050 Z37 1.2MB Drives ..... 1,450</p> <p>NORTH HORIZON, 1 STAR quad drive, HD5 ..... 3,999 ADVANTAGE, 2 quad drives, 64K ..... 2,999</p> <p>CROMEMCO 64K, 12" monitor, 390K floppy, letter quality printer, CP/M type O.S. + word processing + spreadsheet ..... 2875</p> <p><b>*16-bit CPU*</b></p> <p>WICAT S150 1FS 1-user ..... 7,520 256K RAM, CRT, 2 floppies *88000* S150 WS 1-user ..... 8,999 256K RAM, 10MB hard disk, 960KB floppy CRT, OS + 1 language S150-3 WS 3-users ..... 10,800 same as S150 WS S150-6 WS 6-users ..... 12,800 S12K RAM same as S150 WS Graphics, 300 x 400 ..... 900 8510A w/CRT ..... 6,000 320 x 240, DD *LSI/11 graphic* 9600 w/13" color monitor, 640 x 480 ..... 17,000</p> <p>ALTOS ACS8600-10 500KB ..... 8,350 *8086* RAM, 10MB hard disk, 500KB floppy multisusers ACS8000-2 ..... 2,850</p> <p>DEC PDP/11, MINC, Professional ..... Call</p>	<p>Integral Data System</p> <p>PRISM 80 150 cps, 80 col. .... 740 w/graphic 84 x 84 ..... 820 W/color &amp; graphic ..... 1,120 W/all options ..... 1,340</p> <p>PRISM 132 132 col. .... 1,050 w/graphics 84 x 84 ..... 1,130 w/color &amp; graphic ..... 1,430 w/all options ..... 1,690</p> <p>EPSON MX80 w/Graftrax ..... Call MX70 ..... 315 MX80 F/T Graftrax ..... Call MX100 ..... Call</p> <p>NEC PC-8023A ..... 480 DP-9500 ..... 1,300</p> <p>ANADEx MCROLINE 80 ..... 365 OKIDATA 84 sp ..... 1,225 PRINTEX 920 340cps, 144 x 144, ..... 2,450</p> <p><b>*Letter Quality*</b></p> <p>DIABLO 630 ..... 1,995 C.I/OH Starwriter F-10 ..... 1,395 9/35 R.O. .... 1,900 QUME HR-11 excellent ..... 950 BROTHER NEC 7710 ..... 2,299</p> <p><b>MONITOR</b></p> <p>ZENITH 12" green ..... 114 AMDEK COLOR II RGB 13" ..... 775 COLOR I 13" ..... 350 300 G 12" green ..... 179 SANYO 13" color ..... 445 13" RGB ..... 905 12" green ..... 170 12" color ..... 330 BMC A 12" green ..... 99 TM-12 RGB, 8 colors ..... 550 Electrohome RGB ..... 725</p> <p><b>TERMINAL</b></p> <p>ZENITH Z19 ..... 835 ZT-1 w/modem ..... 560 HAZELTINE ESPRIT ..... 595 BEEHIVE DMS smart ter. .... 900 IBM 3101-10 ..... 1,195 3101-12 ..... 1,225 3101-20 ..... 1,400 TELEVIDEO 910 ..... 599 CROMEMCO Compatible ..... 1,350</p>	<p>database</p> <p>dBASE II Ashton-Tate ..... 499 CONDOR I ..... 250 II ..... 450 III ..... 850</p> <p>financial (AR, AP, Inventory etc.) Accounting Plus Software Dimension ..... 450 MSBI ..... Call</p> <p>other VISICALC ..... 199 MICROSOFT softcard ..... 330 FORTRAN 80 ..... 345 BASIC 80 ..... 265 BASIC Compiler ..... 310 SUPERCALC Sorcum ..... 250 Micro Pro WORDSTAR ..... 295 MAILMERG ..... 105 SUPERSORT I ..... 165 Digital Research CPM 2.2 ..... 139 CPMB6 ..... 275 PASCAL MT &amp; 86 ..... 450 IBM Personal Computer Software ..... Call</p> <p><b>DIGITIZER/PLOTTER</b></p> <p>HOUSTON INSTRUMENT HI PAD DIGITIZER DT-11 11" x 11" ..... 725 DT-11A w/APPLE Interface ..... 750 DT114 4 controls ..... 875 HIPLLOT DMP-2 8 1/2" x 11" ..... 920</p> <p><b>MODEM</b></p> <p>PRENTICE STAR RS232 ..... 175 D.C. Hayes Smartmodem ..... 220</p>

**CALL (212) 937-6363**  
free consultation, catalogue

Prices subject to change. American Express, Visa/Mastercard add 3% F.O.B. point of shipment. 20% restocking fee for returned merchandise. Personal checks take 3 weeks to clear. COD on certified check only. N.Y. residents add sales tax. Manufacturers' warranty only.

Computer Channel  
21-55 44th Road  
Long Island City, NY 11101

# Super Specials on SUPERBRAIN II'S

**SUPERBRAIN® DD, \$2099**

**QD, \$2495**

**NEW DOUBLE SIDED 80 TRACK SD, \$2949**



INTERTEC has introduced a new model, the SD (super density) with dual double sided 80 track drives—TWICE THE CAPACITY OF THE QD—. The SD SUPERBRAIN is available from Mini MicroMart for \$2799

SUPERBRAINS come with CP/M; with the addition of an appropriate printer, and the necessary software you can have a complete data processing and /or word processing system.

**NOW FREE MicroSoft Basic 80**

You can take advantage of our MicroPro word processing software special. WordStar for only \$269; We will include MailMerge with WordStar for \$358 or for only \$489 you get the full package— WordStar, MailMerge and SpellStar

## MiniMicroMart stocks the full INTERTEC line.

Basic 80 is FREE, and a complete accounting package—GL, A/R, A/P, and payroll are available to run in MICROSOFT BASIC for only \$269

You can add capacity to your SUPERBRAIN by adding their 10 megabyte DSS Hard Disk. We offer it for only \$2995. We include the adapter cable to the SUPERBRAIN (if requested) at no extra charge.



If you need a distributed processing system, INTERTEC has lowered prices on their full series of COMPUSTARS— the VPU 10, the VPU 20 the VPU 30 and the VPU 40. Virtually any number of these can be daisy- chained to share one of their hard disks, or they can be utilized as a stand alone computer, just like a SUPERBRAIN.

—CALL US FOR PRICING—

SUPERBRAINS and COMPUSTARS come with two built in serial ports, so you can support two printers or a printer and a modem. Among the printers suitable for the SUPERBRAIN are: Centronics 730-3, the 739-3, the 704-9 the TI 810s or 820s, or Okidata 82s, 83s or 84s (serial version) the IDS PRISM series is also suitable. If you choose to use an Epson, you will also have to buy one of their serial interface boards. If you want a letter quality printer there is the NEC 3510 or 7710, the Diablo 630 or the Qume Sprint 9/45.

All prices, F.O.B. shipping point, subject to change. All offers subject to withdrawal without notice. Advertised prices reflect a 2% cash discount (order prepaid prior to shipment). C.O.D.'s and credits cards are 2% higher.

# MiniMicroMart, Inc.

943 W. Genesee St. P.O. Box 2991B Syracuse, N.Y. 13220 (315) 422-4467 TWX 710-542-0431

## Computers and the Special Education Classroom

---

Thomas R. Sicoli  
404 Darlington Dr.  
West Chester, PA 19380

---

These students enter the classroom one or two at a time. They are in wheelchairs, on crutches, or in bed, because they are patients in a children's orthopedic hospital. Dan, for example, was injured in a diving accident and is now a quadriplegic, paralyzed from the chest down. Bob suffered brain damage in an automobile accident; he is now without speech and cannot walk. His memory and concentration are very poor. Jim has been paralyzed since birth. He was born with spina bifida (a congenital defect of the spinal cord). He is normal in some cognitive skills but lags far behind in others. He gave up trying to learn his "times tables" years ago. These are the students for whom the question was asked, "How can computers be used in a special education resource program serving kindergarten through twelfth grade?" In order to answer this question, an extensive search of available Apple software was made (see tables 1 and 2).

A major concern of special educators has always been the difficulty in getting and holding the attention of brain-damaged or socially and emotionally maladjusted students. The student's attention span is greatly improved when using computer-aided instruction. Large color graphics are excellent attention-getters and are also beneficial for those with impaired vision. Programs that refer to the student by name personalize the lesson and keep him or her stimulated. Finally, the instant feedback on every item in the lesson also helps to sustain the student's attention.

Another need in this classroom is for new and innovative instructional strategies. Many special education students need much more repetition of lessons than "normal" students. This can quickly become tiring for both teacher and student. The computer can relieve this drudgery. A student and a computer can work together, leaving the teacher free to work with others.

Records on each individual student can be kept by the computer, with the scores from drills and quizzes automatically recorded. Instructional lessons and cues can be presented automatically. New programs for microcomputers are even exhibiting branching instructional design. Instead of just a drill, programming can contain extra help in the form of remedial lessons for those having trouble with a particular lesson. For example, a student consistently having problems with reducing fractions would automatically receive a remedial lesson or be returned to a previous lesson that covers finding the greatest common factor of two numbers.

Language development is an important part of the special education teacher's job. Computer speech synthesizers show great promise in helping those with speech defects to monitor and shape their own speech effectively. Recording devices can be built into a program to help in this task by playing a master pronunciation and the student's effort back-to-back for comparison. Computers can also be programmed to recognize regular but unintelligible sounds made by those without effective speech and then to output an intelligible word or phrase that enables the student to communicate. For example, a particular sound at a certain pitch could trigger the computer to output the greeting "Hello!" Finally, programs are available to turn the computer into an electronic communicator. The push of a single button can cause an entire pre-programmed sentence or paragraph to be printed on a monitor or piece of paper, or to be spoken by a voice synthesizer.

Valuable skills can also be acquired or improved by using microcomputers. Many disabled people have gotten started on a career in computer programming with courses in computer literacy and BASIC programming. Motor skills, such as typing and eye-hand coordination,

# Best Prices Anywhere! We Beat 'em All

## COMPUTERS:

- ALTOS List,..... Less 20%  
NorthStar  
HORIZON 2Q-64K ..... \$2685  
ADVANTAGE..... \$2985  
TeleVideo  
Computer Systems..... Call  
—New SUPERBRAIN II—



- 64K Double Density Jr., ..... \$1995  
64K Quad Density..... \$2395  
64K Super Density ..... \$2795  
DSS-10 Meg. Hard Disk..... \$2895

### —Cromemco—

- CS-1 List, \$3995..... Our Price, \$3195  
CS-1H List, \$6995..... Our Price, \$5595  
CS-2 List, \$4695..... Our Price, \$3549  
CS-3 List, \$6995..... Our Price, \$5595  
Z2H List, \$9995..... Our Price \$7995  
Soft Ware & Accessories..... Call

**ZENITH**

**data systems**



- Z-89 List, \$2895  
Our Price  
\$2099  
Z-90,....\$2299

## MONITORS:

### —AMDEK—

- 100 ..... \$129  
300 ..... \$189  
Color I ..... \$345  
Color II..... \$759

### —BMC—

- BM-12..... \$159  
1401 RGB 400x160 Res..... \$345  
ZENITH ZYN-121 ..... \$120

## TERMINALS:

### —TeleVideo—



- 910C ..... \$569  
912C ..... \$659  
925C ..... \$719  
950C ..... \$915

### —SOROC—

- IQ-130..... \$585  
IQ-135..... \$719  
IQ-135 w/Graphics..... \$789  
IQ-140..... \$995

### —HAZELTINE—

- 1420 ..... \$589  
1500 ..... \$845  
1510 ..... \$1029  
ZENITH Z-19,..... \$689

## DISK SYSTEMS:

### —MORROW—

- Discus 2D ..... \$835  
Dual Discus 2D ..... \$1385  
Discus 2 + 2 ..... \$1069  
Dual Discus 2 + 2 ..... \$1855  
M5, 5Meg Hard Disk ..... \$1949  
M10, 10 Meg. Hard Disk ..... \$2995  
M26, 26 Meg. Hard Disk ..... \$3349

### —CORVUS—

- 5 Meg. Hard Disk ..... \$2555  
10 Meg. Hard Disk ..... \$3955  
20 Meg. Hard Disk ..... \$4755

## MODEMS:

- D.C.Hayes Smart Modem..... \$219  
NOVATION D Cat..... \$149

## PRINTERS:

### —CENTRONICS—



- 730-1 Parallel..... \$349  
739-1 Parallel..... \$499  
739-3 RS232..... \$599  
704-11 Parallel..... \$1569  
704-9 RS232..... \$1519

### —Texas Instruments—

- TI-810 Basic..... \$1289  
TI-810 Full ..... \$1549  
TI-820 RO Basic..... \$1545  
TI-820 KSR Basic..... \$1739

### —NEC—

- 3510 RS232..... Call  
7710 RS232, 7730 Parallel..... \$2295  
7720 RS232..... \$2795  
8023..... \$495

- Diablo 630RO..... \$2049  
Smith-Corona TP-1..... \$685

QUME..... Call For Prices

### —Paper Tiger—

- Prism 80 w/o color..... Call  
Prism 132 w/o color..... Call  
Color Option (for 132)..... Call

### —Epson—

- MX-80 ..... \$441  
MX-80FT..... \$548  
MX-100 ..... \$745

### —OKIDATA—

- Microline 80..... \$329  
Microline 82A..... \$469  
Microline 83A ..... \$739  
Microline 84..... Call

C.ITOH..... Call For Prices

Prices apply to *prepaid orders only* and reflect a cash discount. Charge card orders are slightly higher.  
Most items are in stock for immediate delivery in factory sealed cartons, with full factory warranties. N.Y. state residents must add appropriate sales tax. Prices do not include shipping. C.O.D. orders require 25% deposits. All prices are subject to change and all offers subject to withdrawal without notice.

# COMPUTERS WHOLESAL

P.O. Box 91 Brewerton, New York 13029

(315) 472-3055

# Could you pass this Red Cross swimming test?

## SWIM:

1. Breaststroke — 100 Yds.
2. Sidestroke — 100 Yds.
3. Crawl stroke — 100 Yds.
4. Back crawl — 50 Yds.
5. On back (legs only) — 50 Yds.
6. Turns (on front, back, side).
7. Surface dive — underwater swim — 20 Ft.
8. Disrobe — float with clothes — 5 mins.
9. Long shallow dive.
10. Running front dive.
11. 10-minute swim.

Anybody who's taken a Red Cross swim course knows how tough it can be. There's a good reason.

We believe drowning is a serious business.

Last year alone, we taught 2,589,203 Americans not to drown—in the seven different swim courses we offer all across the country. (Incidentally, most of the teaching—as with almost everything American Red Cross does—is done by dedicated volunteers.)

A good many of the youngsters not only are learning to keep *themselves* safe. Thousands upon thousands of them are learning to become lifesavers.

And the life they save—may be your own.



**Red Cross  
is counting  
on you.**

A Public Service of This Magazine & The Advertising Council



Hartley Software  
3268 Coach Lane #2A  
Kentwood, MI 49508

Letter Recognition—Kindergarten and first grade— Large characters	\$19.95
Word Families—Changing letters to form new words	\$29.95
Skilldrills—Arithmetic & Verbal—Large characters	\$14.95–\$79.50
Clock-Telling Time—Clock and digital style times (Scorekeeping automatic with most programs)	\$39.95

Educational Activities Inc.

POB 392

Freeport, NY 11520

Introduction to Mathematics on the Computer—Level 1-4	\$39.95
Basic Math Competency Skill Drills—Covers +, -, x, /, fractions, decimals, areas	\$203
O'Brien Vocabulary Placement Test—Self-scoring	\$19.95
Our Weird and Wacky World—Literal and critical reading using the Cloze technique	\$79.90
English Basics—Parts of speech, synonyms, antonyms, homonyms	\$269.95
Flash Spelling—Teachers may add their own words (Most are self-scoring)	\$33.50

George Earl

1302 South General McMullen  
San Antonio, TX 78237

Spanish Hangman—1600 words and 450 sentences	\$29.95
French Hangman—500 words and 175 sentences (Self-scoring)	\$29.95

Grover Associates

c/o Scholastic Inc.

904 Sylvan Ave.

Englewood Cliffs, NJ 07632

The Microcommunicator Version C—For a child without speech	\$46
The Microcommunicator Version A—Adult vocabulary	\$46

Program Design Inc.

11 Idar Court

Greenwich, CT 06830

Pre-School I.Q. Builder—Readiness activities, colors and shapes	\$19.95
Vocabulary Builder 1—Beginner—J.H.S.	\$19.95
Vocabulary Builder 2—Advanced—S.A.T. preparation	\$19.95
Analogies—S.A.T. preparation with instruction	\$19.95
Number Series—Projecting Series—S.A.T. preparation	\$19.95
Spelling Builder—Rules and tests	\$23.95
Reading Comprehension—What's Different? Categorization (2-4)	\$19.95
Story Builder—Word Master—4th grade and up	\$19.95
Step-by-Step Course—Computer programming in BASIC with text	\$59.95

BLS Inc.

2503 Fairlee Rd.

Wilmington, DE 19810

Arithmetic Fundamentals—Tutor Course 2-5—29 disks	\$1479
Reading Comprehension—Tutor Course 3-6—15 disks	\$714
Fractions—A Review Course—Tutor Course 6-7— 15 disks (color graphics)	\$765
(Programs incorporate branching instruction design for remedial help.)	

Edu-Ware Services Inc.

POB 22222

Agoura, CA 91301.

Algebra 1—Definitions, Sets, Evaluation Expressions	\$39.95
Perception 3.0 Visual Discrimination, Shapes and Length	\$24.95

**Table 1: Publishers of educational software packages and their products. These packages have been effective in a special education resource room.**



# TEAM PLAYERS.

## Master/Slaves...

At Advanced Micro Digital, we believe in co-operation between computers and their operators. That's why our new team of S-100 master and slave processors are designed with your team in mind and feature superlative reliability and ease of operation.

Our team captain is SUPER QUAD, a unique multi-function master processor combining 64K of bank selectable RAM, single- and double-density floppy disk controller, system monitor EPROM, Z80A CPU, two serial and two parallel communication ports on a single board.

The players consist of one or more SUPER-SLAVES, the latest addition to Advanced Micro Digital's line of superior multi-function S-100 boards.

Each SUPER-SLAVE is a powerful single-board slave processor designed for use with the SUPER QUAD in either network or stand-alone configurations. The outstanding features of the SUPER-SLAVE include:

- A DEDICATED Z80A CPU FOR EACH USER
- IEEE-696 standard conformity
- 4 serial, 2 parallel interface ports
- 2/4K EPROM (monitor)
- 64/128K bank switchable RAM
- One year warranty
- Turbo-DOS™, the state-of-the-art operating system with an advanced failure detection and recovery facility that makes the master-slave network virtually crash-proof.
- Also, for the first time CP/NOS® operating system from Digital Research. Plug as many SUPER-SLAVES into the BUS as you need users.

Your team needs the strong support of the SUPER QUAD/SUPER SLAVE team from Advanced Micro Digital Corporation. The Super System includes SUPER QUAD and CP/M operating system. The shugart SA-1000 or quantum Q2000 hard disks are also supported.



For more information write or call: Sales Dept.

12700-B Knott Street • Garden Grove, California 92641 • (714) 891-4004 TELEX 678401 tab Irlin

® Registered Trademark of Digital Research Corp.  
™ Registered Trademark of Software 2000 Inc.

© Copyright 1981 Advanced Micro Digital Corp.  
Circle 12 on inquiry card.



Gamco Industries Inc.  
POB 310 P  
Big Spring, TX 79720-0120  
(915) 267-6327

The Micro Center  
POB 6  
Pleasantville, NY 10570  
(914) 769-6002

Opportunities for Learning Inc.  
8950 Lurline Ave.  
Chatsworth, CA 91311  
(213) 341-2535

Scholastic Software  
Scholastic Inc.  
904 Sylvan Ave.  
Englewood Cliffs, NJ 07632  
(212) 867-7700

**Table 2: Mail-order software retailers specializing in educational software. These retailers can supply most of the software listed in table 1.**

can be taught and evaluated with existing software. Mathematical problem solving, equation writing, and plotting on a graph are just three of the many mathematical skills being taught with the aid of computers. Students can sharpen skills for the S.A.T. or G.E.D. tests. Finally, visual perception, manual dexterity, and eye-hand coordination can be taught through computerized electronic games, accessed through the keyboard paddles or joysticks. These games can be a motivational reward to be earned by students for achievement in other areas.

Computers are highly adaptable tools and endlessly patient teachers. They can give the special education student useful skills to cope with everyday life, a method to communicate his or her needs, and perhaps a brighter outlook on life. ■

**For The Best In Price, Selection and Delivery,**

**Call Now TOLL FREE**  
**800-368-3404**

**(In VA, Call Collect 703-237-8695)**

**AMPEX • INTERTEC • TEXAS INSTRUMENTS • GENERAL DATA  
COMM. • ANDERSON JACOBSON • C. ITOH • QUME • BEEHIVE •  
DATASOUTH • DIABLO • CENTRONICS • NEC • PRENTICE**

**SUPERBRAIN MICROS**

**INTERTEC:**

64K DD\* ..... **ONLY \$1975**  
64K QD\* ..... **ONLY \$2350**  
64K SD\* (96TPI) .. **ONLY \$2750**

\* (includes M/Soft BASIC)

DDS-10 Meg  
(Hard Disk) ..... **ONLY \$3195**

**PRINTERS**

**NEC:**

7710 ..... \$2196  
7715 ..... Call for Special Price  
7730 ..... \$2196  
7720 ..... Call for Special Price  
7725 ..... Call for Special Price  
Std. Forms Tractor ..... \$ 200  
3510 ..... \$1390

**DATASOUTH:**

DIABLO: 630-R102 ..... \$1995  
630-R110 ..... \$1795  
630-R153\* ..... \$1745

\* (for IBM P.C., Apple II, TRS-80)

630-K104 (KSR) ..... \$2385  
620-SPI ..... \$1195

**QUME:**

Sprint 9, 35 KSR ..... \$1840

Sprint 9, 45RO, Lim. Pan. \$1845  
Full Panel ..... \$1969  
Sprint 9, 55 F.P.Ex.Mem. \$2186  
Sprint 9.55RO, Ltd. Ex.Mem. \$2095  
Bi-Dir. Forms Tractor ..... \$ 199

**TERMINALS**

**AMPEX:**

Dialogue 30 ..... \$ 775  
Dialogue 80 ..... \$ 939

**BEEHIVE: (SMART DISPLAY)**

DM5 ..... Call  
DM5A ..... Call  
DM310 (3101 Emulator) .... Call

NOTE: IBM and Burroughs compatible terminals available. Please inquire.

**C. ITOH**

CIT 101 ..... \$1350

**TEXAS INSTRUMENTS:**

745 Standard ..... \$1390  
745 Std. (Reconditioned) ... Call  
810 Basic ..... \$1249  
810 Package ..... \$1439  
820 Package RO Package ..... \$1610  
820 KSR Package ..... Call  
840 RO Basic ..... \$ 795  
840 RO Tractor Feed Pkg. .. \$1059

**COUPLERS**

PRENTICE STAR: 300 Bd. . \$ 124

**DISC DRIVES**

**QUME:**

Data Trak 5 . . . \$300 or 2 for \$549  
Data Trak 8 . . . \$525 or 2 for \$999

**SOFTWARE**

BISYNC-3780 ..... \$ 769  
Wordstar ..... \$ 289  
Data Star ..... \$ 194  
Mail Merge ..... \$ 99  
Spell Guard ..... \$ 229  
Plan 80 ..... \$ 249  
Super Calc ..... \$ 249  
Wordstar (IBM P.C.) ..... \$ 284  
Mail Merge (IBM P.C.) .... \$ 96  
d Base II ..... \$ 529  
CalcStar ..... \$ 189  
SuperSort ..... \$ 186  
Nevada Cobol ..... \$ 176

**Special! While They Last!**

**SOROC TERMINALS**

IQ 120 ..... **ONLY \$625**  
IQ 130 ..... **ONLY \$525**  
IQ 140 ..... **ONLY \$989**

In addition, we can make EIA RS232 or RS449 cables to your order, and supply you with ribbons, printer stands, print wheels, thimbles for all printers listed. And many, many more items. CALL NOW.

All items shipped freight collect either motor freight or UPS unless otherwise specified. All prices already include 3% cash discount. Purchase with credit card does not include discount. Virginia residents, add 4% Sales Tax. For fastest delivery, send certified check, money order or bank-wire transfer. Sorry, no C.O.D. orders. All equipment is in factory cartons with manufacturers' warranty (honored at our depot.) Prices subject to change without notice. Most items in stock.



**TERMINALS TERRIFIC**



Terminals Terrific, Incorporated, P.O. Box 216, Merrifield, VA 22116, 800-368-3404 (In VA, Call Collect 703-237-8695).



# The QUAD<sup>T.M.</sup>

The Effortless Way  
To Create Your Data Base  
And Related Applications.



The QUAD is a relational data base management system and applications developer allowing the non-programmer to develop his or her own business and personal applications around a powerful relational data base. Some of the applications you can build with the QUAD are:

#### BUSINESS

- Accounts Payable
- Agricultural Management
- Construction Management
- General Ledger
- Human Resource Management
- Inventory Control
- Job Costing
- Mail List
- Order Entry
- Payroll
- Personal Scheduling
- Professional Time and Billing
- Property Management
- Sales Analysis

#### PERSONAL

- Appointment and Gift Register
- Budgeting
- Car Maintenance
- Family Medical Data
- Home Improvement Information
- Income Tax Information
- Insurance Information
- Inventory Information
- Investment Information
- Recipe Information
- Shopping Lists
- Time Management
- Vacation Planning

The QUAD is designed for YOU, the computer user who wants to take full advantage of his computer.

#### EXTENSIVE REPORTING CAPABILITIES

The QUAD enables you to create an unlimited number of reports in any specific size or form you desire using data from the QUAD database or another data-base. You may process and/or print data during any report.

#### PROCESSING DATA

- access information in up to 10 or more files during a report
- perform arithmetic calculations on any data from any file

- update and/or create files based on report processing
- easily compare date information for quick aging analysis
- perform up to 5 levels of subtotaling within each report
- retrieve records in sequential or indexed order
- perform processing based on comparison of data such as nested IF THEN logic

#### PRINTING DATA

- utilize your printer's capability by printing on any size paper anywhere on the page
- print checks using the English equivalent for dollar and cent values
- specify content of page headings, control headings and footings, detail lines and total lines
- pause between printing of forms

#### SAMPLE REPORT

DATE	DESCRIPTION	AMOUNT	BY	DATE	AMOUNT	TOTAL
12/15/82	Auto Insurance	100.00				100.00
12/15/82	Gas	25.00				125.00
12/15/82	Oil	15.00				140.00
12/15/82	Tire	10.00				150.00
12/15/82	Wash	5.00				155.00
12/15/82	Wax	5.00				160.00
12/15/82	Wash	5.00				165.00
12/15/82	Wax	5.00				170.00
12/15/82	Wash	5.00				175.00
12/15/82	Wax	5.00				180.00

#### POWERFUL UPDATING CAPABILITIES

The QUAD gives you two methods to update data within the data base. One way is directly through the terminal using a data entry process. The other is through batch updating based on existing data within the data base.

- update as many as 10 or more files simultaneously, using the batch update mode
- totally user defined screens
- full screen editing
- record sizes up to 900 characters
- perform calculations based on data entered and data residing in other files
- access three different help screens during the data entry process
- utilize your terminal's video capabilities when creating your terminal update screens

- restrict all or some data fields from future changes
- edit each data field for items such as phone numbers, numeric data, alphanumeric data, date, time, social security number, etc., or your own defined edits
- IF-THEN logic available during both terminal and batch updating

#### SAMPLE SCREEN

Order Entry Line Item for CUST Order #	1005	Classic Motors
Customer's P.O. Number	4325	
Subscription #	15	Margin Smith
Item #	C2507	
ITEM	Nuts and Bolts	QTY 100.00
		Charge 50
		(Subtotal) 50.00

Press F10 for Help

#### OTHER FEATURES

**SORT, INDEX, and REORGANIZE** data files quickly and easily. Also link to user-written programs directly from the QUAD. Automatically generate menus to access each of your applications.

The QUAD comes complete with an Accounts Receivable application ready for your use and a Checkbook Balancing application for you to build.

The suggested retail price for all this is only \$495.00.

Available for most CP/M compatible hardware.

To order your copy of the QUAD, contact your computer dealer, or call QuanTeckna Research today.



**QuanTeckna<sup>®</sup>**  
**Research Corporation**

6902 220th St. S.W. MOUNTLAKE TERRACE, WA  
98043 206/364-6940 or 206/771-2488

CP/M is a trademark of Digital Research Inc  
QUAD and QuanTeckna are trademarks of  
QuanTeckna Research Corporation

# Adaptive-Firmware Card for the Apple II

*Alternative input techniques give physically disabled individuals immediate access to standard software.*

---

Paul Schwejda  
Alternative Communications Project  
Child Development  
and Retardation Center  
WJ-10 University of Washington  
Seattle, WA 98195

Gregg Vanderheiden, Director  
Trace Research and Development Center  
314 Waisman Center  
1500 Highland Ave.  
Madison, WI 53706

---

At the present time, interest is growing in the use of microcomputers to help solve the needs of people with disabling conditions. A number of programs allow individuals to use a computer even though they may be too severely disabled physically to use the keyboard directly.

Presented here is a low-cost adaptive-firmware card that can be inserted into an Apple II microcomputer to provide a variety of "transparent" input routines including scanning, Morse code, and direct selection techniques. (The term "transparent" here indicates that the routines work in conjunction with other programs without requiring that the programs be altered in any way.) In addition to providing "keyboard" input, the card can also simulate the use of game paddles and switches for people who cannot use the game paddles themselves.

A large number of programs have been written that allow disabled individuals to accomplish specific functions with a microcomputer. A variety of special single-switch scanning routines, expanded keyboards, and encoding routines have been developed; some of these programs require only a slight movement of one eye to allow an individual to select words, phrases, or commands from menus presented on the video screen. Most of these programs, however, cannot be used in conjunction with other standard microcomputer software packages. It is not possible, for example, to use many of them to control Visicalc (a spreadsheet program) or to enter characters and words into Easywriter (a text-editing program). As a result, disabled persons are able to tap only part of the potential of microcomputers and the vast world of software that is available.

In order to overcome this barrier and allow physically disabled individuals access to standard software, transparent techniques and modifications are being developed. These allow the disabled user to access the computer in such a way that both the computer and any software written for it function normally, just as if the computer were not controlled through a special input routine. Truly transparent techniques allow total access to any software written for the computer.

One strategy for providing transparent input is the use of a keyboard emulator driven by a separate communication aid or another computer. Although very powerful and very transparent, this approach is costly because it involves the expense for both the emulator module and the communication aid or second computer.

# Leaps and bounds ahead of any other micro.



## The New Gazelle 8086 16-Bit Computer.

In the microcomputer jungle, one beast stands alone. The new Gazelle 8086 from Seattle Computer.

Like the animal for which it's named, the Gazelle is one of the fastest micro computers you can buy. And the Gazelle is more than just fast. It's fully integrated and ready to run with BASIC, FORTRAN, Pascal, COBOL, spread sheet simulator, and word processor available now from Seattle Computer.

To show you how swift our sleek new Gazelle is, it includes: an 8 Mhz. 8086 CPU set, 128K of RAM, three RS-232 serial ports and a parallel port, two 8" double-sided double-density floppy disk drives with controller (which provide 2.5 megabytes of storage), MS-DOS operating system



(fully compatible with IBM PC-DOS, SB-86).

Also provided at no extra cost is Microsoft's BASIC Interpreter and the Perfect Writer word processor. There

is space and even a built-in power supply for our future Winchester hard disk option. All in one package. Just add a terminal and printer and you're in business.

Here is the best news. Gazelle is not only built to move quickly, it's priced the same way. You can buy the fully tested Seattle Computer Gazelle from your local dealer for \$5995.

Call toll-free 1-800-426-8936 for more information. Dealers who have been hunting for a swift and sleek Gazelle are encouraged to call.

 **SEATTLE  
COMPUTER**

1114 Industry Drive, Seattle, Washington 98188

Circle 418 on inquiry card.

## Basic Description

The purpose of the adaptive-firmware card is to provide completely transparent control of the Apple II to people with severe physical disabilities who are unable to use the keyboard and game paddles in their normal fashion. To accommodate the largest number of individuals, 1 of 10 different input modes may be selected by using a thumbwheel switch on the box mounted to the side of the Apple II (see photo 1). With each of the techniques, the normal keyboard remains active and can be used at any time. Also, a number of options available with the card facilitate its use by offering adjustable timing rates.

The complete interface consists of a specially designed printed-circuit card that is inserted in slot 7 of the Apple II computer and a small plastic box that snaps onto the side of the computer (this contains the input jacks and the mode-selection thumbwheel). The card has a jumper cable ending in a 16-pin DIP (dual-inline pin) connec-

tor; it is very similar in appearance to the Apple language card. The DIP connector replaces a decoder IC (integrated circuit) located directly in front of slot 7 and gives the firmware card control over the I/O (input/output) decoding in the Apple.

To install the firmware card, simply remove the 74LS138 decoder immediately in front of slot 7 and insert the jumper plug. Then insert the adaptive-firmware card into slot 7 and snap the interface box to the side of the Apple II. Photo 2 shows the adaptive-firmware card installed. Installation (or removal) takes less than a minute and, unlike that of other keyboard emulators, does not require the removal of the bottom of the Apple, nor does it require that the keyboard be disconnected from the main circuit board; this is done electronically during operation.

## Operation

To use the adaptive-firmware card, select the desired output mode with the thumb switch and turn on the

computer. The disk will not be loaded immediately; instead, a message will appear on the screen asking for the sampling (timing) rate desired for the input routine. Once the rate is entered, the disk will boot as during normal operation of the Apple II. From this point on, whenever input is required, you may use either the keyboard or the selected special input method. (The selected input method can be changed, as can the rate, simply by resetting the system twice.) Now let's examine the available input modes.

With the switch set in the *normal-keyboard* position, the Apple II acts as if the firmware card is not installed in the Apple. Input is accepted from the keyboard in the usual manner.

With *one-switch scanning*, all input is handled through a single switch. When you press the switch, an array of letters and symbols will appear at the bottom of the screen, and the cursor will automatically begin scanning at the rate previously set. The letters are arranged in groups, and the

---

## Now available from your computer store—the whole line of AJ couplers and modems.



Starting now you can buy AJ acoustic data couplers and modems directly from your local computer store.

Not just selected models. Any models. Ranging from the 0-450 bps A 242A, the world's most widely used acoustic data coupler, to the revolutionary AJ 1259 *triple modem* that handles 300 bps Bell 103, 1200 bps Bell 212A, and 1200 bps VA 3400 protocols.

Whether you need full or half duplex or both in one; originate or answer, auto answer, acoustic coupling, or direct-connect—there's a model for you in the AJ line.

Starting now you don't have to settle for second best.

For the location of your local computer store handling the AJ line, call toll-free:

**800/538-9721**

California residents call 408/263-8520, Ext. 307.

 **ANDERSON  
JACOBSON**



## YOU PICK THE COMPUTER, MICROPRO™ MAKES IT PERFORM.

There are a lot of fine names in microcomputers. But there's only one name in software to remember. MicroPro. Because MicroPro has taken the best ideas in business software and put them together to make the MicroPro Software System™—a family of software products that work together on more than 100 of the most popular brands of microcomputers, probably including yours.\*

### Software makes the difference.

The key to getting the most out of your computer is the software you use. And the Software System is designed to get the most out, faster. The Software System is our new name for the MicroPro family of software products, each remarkably powerful and versatile—and even more so when you combine them.

The products: WordStar® (word processing), MailMerge™ (WordStar option—personalized form letters and other file-merging uses); SpellStar™ (WordStar option—spelling checker); DataStar™ (data entry and retrieval); CalcStar™ (electronic spread sheet and financial modeling); SuperSort™ (sorting, selecting, and merging); and WordMaster® (video text editing).

### More solutions, less work.

The Software System enables you to use your microcomputer to its fullest with less time and effort. That's because, for one thing, most MicroPro products have similar methods of operation, so it's easier to move from one product to another. And they readily adapt to your way of doing business, instead of forcing you to make changes to fit a rigid software package, like you have to do with many other software products. Most important, you can combine MicroPro products' information and abilities. The result: a lot more ways to make your

business more productive than you'd get from just using each product by itself.

### The System doesn't stop.

Count on MicroPro to keep expanding the Software System with new products that make it even more useful and powerful in your business. Coming this year: a series of in-depth accounting packages; InfoStar™, a powerful report generator and partner to DataStar; and StarBurst™, a new kind of software that will link our products together into an even friendlier and easier to use package.

If you're shopping for a computer, we recommend you shop for software even more carefully. After all, there are a lot of good hardware systems to choose from. But there's only one Software System. From MicroPro.

To get our brochure on the MicroPro Software System, visit any of our 1200 dealers around the world.

Or phone toll-free 800-227-2400, ext. 933  
(In California 800-772-2666, ext. 933.)



**MicroPro™**  
INTERNATIONAL CORPORATION

\*Ask your MicroPro dealer to let you know which microcomputers can use MicroPro software. For the IBM® Personal Computer, WordStar and MailMerge are now available—other products coming. MicroPro Apple™ software requires a CP/M®-Z80® adaptation device. IBM is a registered trademark of International Business Machines Corp. Apple is a trademark of Apple Computer Inc. CP/M is a registered trademark of Digital Research, Inc. Z-80 is a registered trademark of Zilog, Inc. © 1982 MicroPro International Corp.

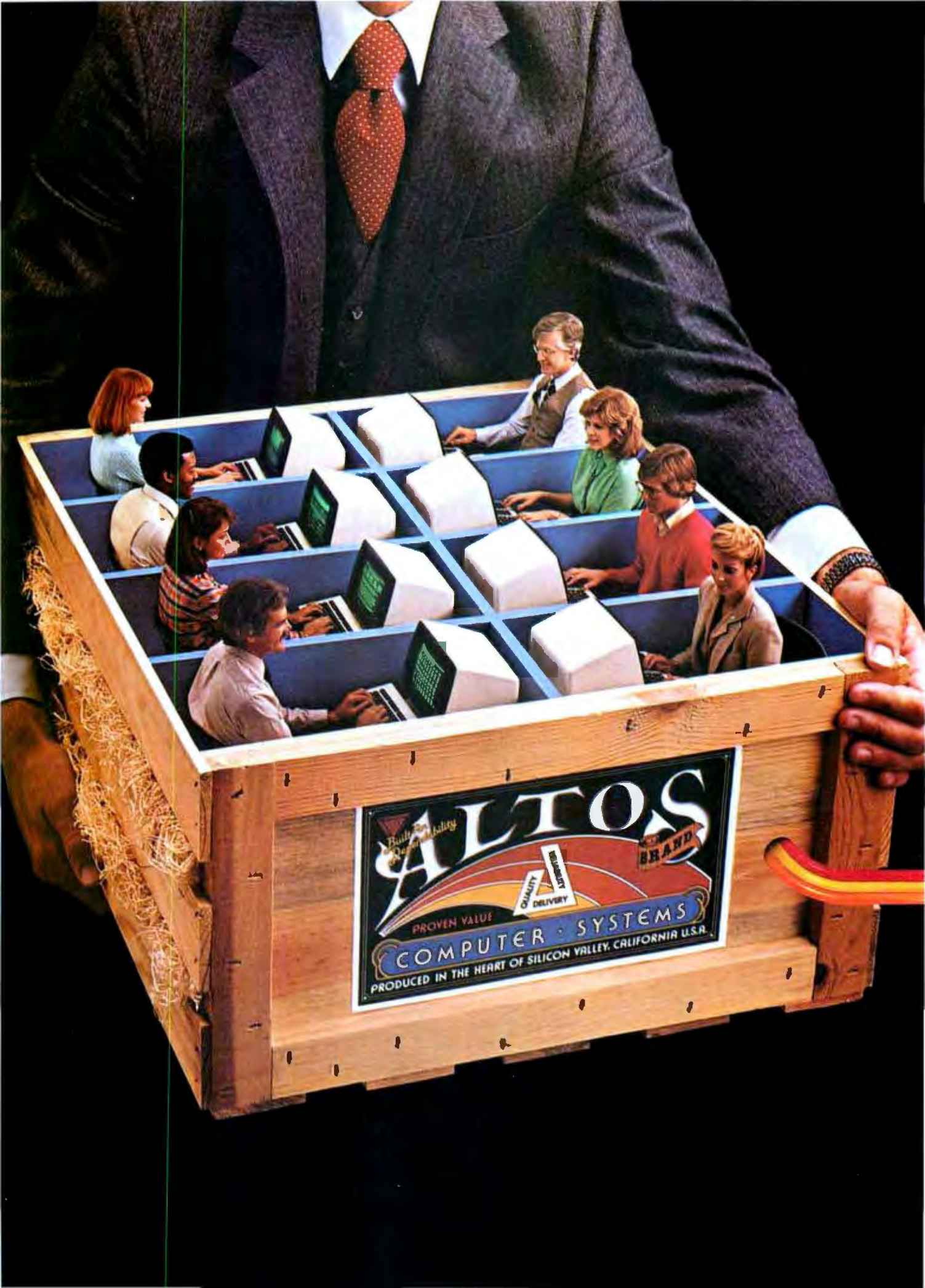

**ALLOS**  
COMPUTER SYSTEMS  
PRODUCED IN THE HEART OF SILICON VALLEY, CALIFORNIA U.S.A.

Builds On  
Quality  
Reliability

PROVEN VALUE

QUALITY  
DELIVERY

SUPPORT  
SERVICE

BRAND

# EIGHT USERS TO GO

**Pick up an Altos 16-bit, UNIX-based computer system today, and get minicomputer networking power at a microcomputer price.**

Looking for a powerful, yet affordable, 8-user computer system that has everything your business needs, including communications?

Then get your hands on an ALTOS<sup>®</sup> field-proven, XENIX<sup>™</sup>/UNIX<sup>™</sup>-based ACS8600 microcomputer.

Our powerful 16-bit 8086 is packed with an 8089 for disk/memory interface, an optional 8087 math processor and an intelligent Z80<sup>™</sup> I/O, which share the workload for faster execution and response.

A unique memory management and protection system subdivides up



Founded in 1977, Altos has already delivered more than 25,000 multi-user systems to major OEM customers. Plus Altos maintains a worldwide sales and service network.

So when you want a multi-user, multi-tasking computer system that has the communications capabilities your business demands, and you want it today, pick up an Altos. For further information, call our toll-free number or write:

Altos Computer Systems,  
2360 Bering Drive,  
San Jose, CA 95131.  
Telex 171562 ALTOS SNJ  
or 470642 ALTO UI.

to one megabyte of memory (500K of RAM is standard), automatically giving each user the maximum available. Built-in Error Detection/Correction (ECC) maintains system integrity. And it's all available today on our highly reliable, fully socketed, proven single board.

Altos has exactly what you need for a smooth migration into the office of the future. Communications and local networking support, including Ethernet<sup>™</sup> and ALTOS-NET<sup>™</sup> for inter-Altos networking. Large data storage capacity—integrated Winchester, floppy and tape back-up in a wide range of configurations and capacities, from 20 to 80 megabytes, starting with the ACS8600-12 with 20 MBytes and the ACS8600-14 with 40 MBytes. Plus support of popular multi-user operating systems like XENIX/UNIX, MP/M-86<sup>™</sup> and OASIS-16.

Produced in the heart of California's technologically fertile Silicon Valley, Altos microcomputers are the professional choice of Fortune 500 companies, computer service organizations, major software developers, and even mainframe computer manufacturers.

## INTER-ALTOS LOCAL NETWORK



## ETHERNET

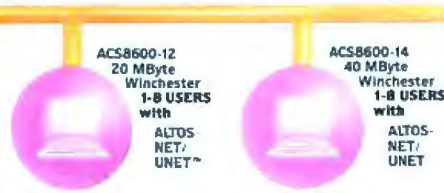

## REMOTE COMMUNICATIONS



**Packed with fresh ideas for business**



**800-538-7872**  
(In Calif. 800-662-6265)

Circle 21 on inquiry card.

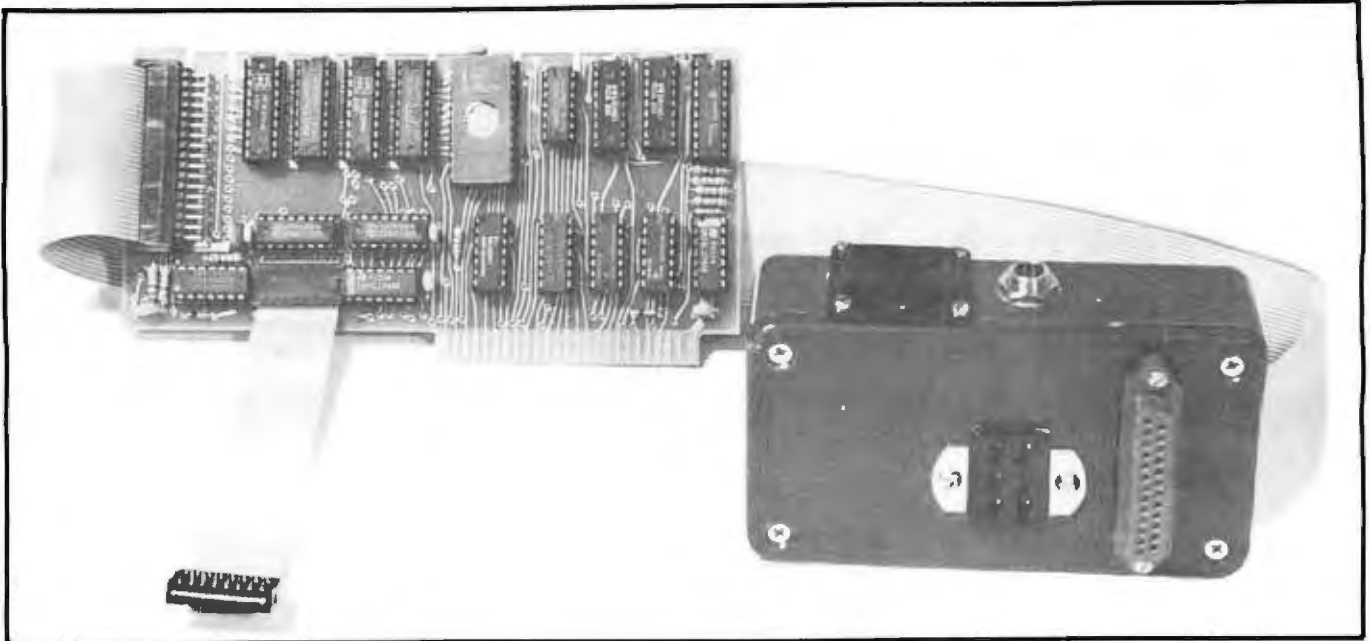

**Photo 1:** The adaptive-firmware card. The device allows disabled users to run standard, unmodified software (such as games, Visicalc, Easywriter, etc.) using any of 10 input routines, some of which require use of only a single switch. (Photo by Ed Crabtree.)

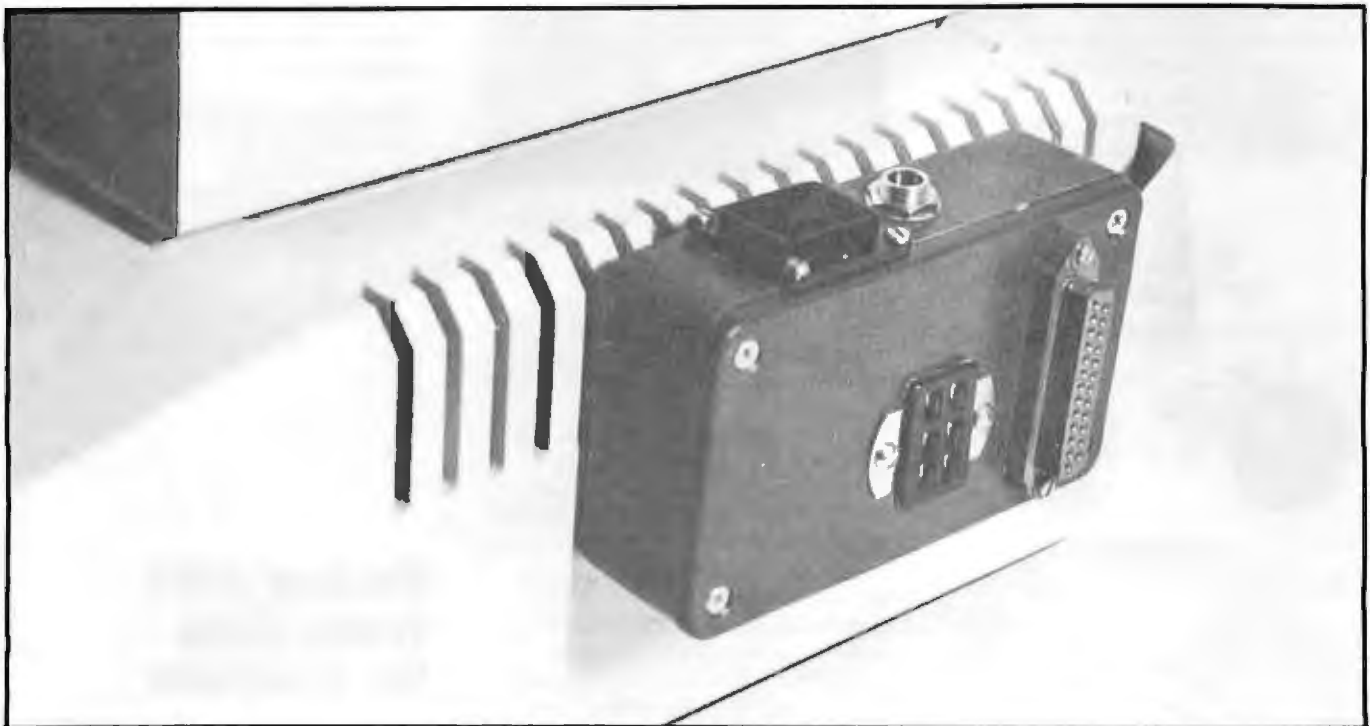

**Photo 2:** The adaptive-firmware card as installed on an Apple II. The device plugs into slot 7 of the Apple; it remains hidden to the Apple's system yet allows the disabled user complete access to the Apple and its software. (Photo by Ed Crabtree.)

groups are scanned first. When you select the desired group, the cursor will then scan the individual letters or symbols within that group; they are arranged in such a fashion that the most-used letters are easiest (that is, fastest) to reach (see table 1). This routine uses the screen without altering the contents of the screen, and can

be used in a transparent fashion with any screen-display program, including those programs that use the graphics screens.

When *step scanning* is selected, all input is controlled through a single switch, as in one-switch scanning. When you press the switch, an array of letters appears at the bottom of the

screen, but the cursor does not automatically begin scanning. In step scanning, you hit the switch repeatedly to advance the cursor group by group. When you reach the desired group, wait a moment. After a brief delay (the duration is user-selectable), the group will begin flashing. Then you hit the switch repeatedly to ad-



vance, letter by letter, within the group. When you reach the desired character, wait again. After another brief delay, the computer will accept the letter as if it had been typed on the keyboard. (This method is useful for individuals who are unable to handle the precise timing required for the one-switch scanning method.)

*Inverse scanning* operates in the same manner as one-switch scanning except that you hold the switch down to scan and release it to select a group or item.

In the *Morse code 1* mode, you press a single switch to send short or long signals ("dits" and "dahs") to the computer. International Morse code or any other code can be used. In addition, all other signals available from the keyboard are also supported, including Repeat and Reset (see table 2).

With *Morse code 2*, two switches are used to form an automatic keyer. One switch sends dits, and the other sends dahs. If either switch is held down, it will send out a series of dits (or dahs) until released. In addition, the software for this mode has a memory buffer and will allow you to get ahead of the computer; thus, if you send "dah dit dah" and hit the dit switch before the first dah is finished, the firmware card will still accept the input.

In the *assisted-keyboard* mode, two auxiliary switches are used for the Shift and Control functions. If you hit the auxiliary Control switch once, the next character will be a control character, but following key-strokes will be unaffected. However, if you hit the auxiliary Control switch twice, the system will lock in the Control mode, and all subsequent key presses will be sent as Control keys until the auxiliary Control switch is activated a third time. The auxiliary Shift switch operates in the same fashion. These switches allow a one-finger typist or someone using a headstick to type all shift and control codes.

A special mode is also provided that allows the Repeat function. To repeat a character, first type the character on the keyboard. Then ac-

Array	Contents	Special Meanings
Alphabet	R:#+ EOHVY TIRUP ANL BK SMFVQ DCXJZ G.I?	R carriage return < backspace # call numbers array . call punctuation array + repeats last character
Numbers	R:A. 1234 567 890+ *-/=	R carriage return < backspace A call alphabet array . call punctuation array * multiplication symbol
Punctuation	.,?! #"S% '( )* / ^ _ +;@/ -= REC	R reset E escape C control

Table 1: *Speed-oriented grouping. To maximize the user's speed, the letters are grouped so that the most-used letters take the least time to reach. Spaces can be generated by stopping at any space in the array. Numbers and special characters are accessed through special scanning lines called up from the main scan line using the "#" and "." characters.*

tivate the auxiliary Shift switch, followed by the auxiliary Control switch. As long as you hold down the auxiliary Control switch, the last

character typed will repeat. (Activating the Control switch first followed by the Shift switch will result in a shifted control character,

# DOUBLE YOUR DISK SPACE INSTANTLY!



IMAGINE  
ELIMINATING  
YOUR CRAMPED  
DISK STORAGE  
PROBLEMS  
IN LESS THAN  
FIVE MINUTES



THE G&M SYSTEMS' UPGRADE KIT WORKS ON VIRTUALLY EVERY BRAND OF SINGLE SIDED FLOPPY DISK PRESENTLY MANUFACTURED

G&M SYSTEMS, P.O. BOX 111  
FLOURTOWN, PA. 19031

Please send me:

— 5½" Upgrade kit(s) @ \$25.00

— 8" Upgrade kit(s) @ \$28.00

— Order both and save \$14.00

— Combo kit(s) 5½"&8" @ \$39.00

Total Enclosed \$ \_\_\_\_\_

We pay all taxes and shipping

Check  Money Order

NAME \_\_\_\_\_

ADDRESS \_\_\_\_\_

CITY \_\_\_\_\_

STATE \_\_\_\_\_

ZIP \_\_\_\_\_

# The Choice of

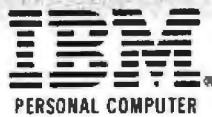

## IBM-PC SUPPLY CENTER PERIPHERALS & SOFTWARE FOR THE IBM PC

**PERSONAL COMPUTER**

**HARDWARE:**

CORVUS, Hard Disk Systems	See Corvus section this page		
Microsoft, 64K RAM Card	New	\$395	20%
128K RAM Card	New	\$555	20%
256K RAM Card	New	\$875	20%
64K RAM Chips	New	\$150	20%
Quadram, Quad Board 256K, 4 function bnd	New	\$689	31%
16 Products, Joystick	New	\$49	25%

**SOFTWARE:**

Automated Sim, Temple of Apshai	\$29	25%
Cavalier, Championship Backback	\$29	25%
Continental Home Accountant Plus	\$112	25%
Denver, Easy Exec Accounting Sys)	\$545	25%
Infocom, Deadline	\$39	25%
Zork I	\$23	25%
Zork II	\$23	25%
Innovative, T1M III (in DBMS)	\$369	25%
ISM, Mathpage	\$69	25%

**\* Insolt, Accountant**  
For each GL, A/R, A/P or Payroll Absolutely the best IBM PC accounting software we have seen. We use it and recommend it highly. A best buy! \$99

Info, Unlimited		
Easyenter II	New	\$259 25%
Phone Support on Easyenter II	Call	Call
Easypeller (88K words)	New	\$129 25%
Easyler (in DBMS)	New	\$289 25%
Macro Pro, Wordstar	New	\$249 40%
MailMerge	New	\$79 40%
SpellStar	New	\$149 40%
Sorcum, Superwriter	\$295	25%
Super Calc	\$219	25%
Visicorp, Visicalc	\$159	20%
Visicalc/256K	\$199	20%

## CP/M BUSINESS & DEVELOPMENT SOFTWARE

Adventure, Adventure's XI to XII inclusive, B*	\$95	26%
* Ashton-Tate, dBase II, B*	\$495	30%
Datasoft, Mychess, B*	\$39	25%
Fox & Geller, Quickcode for dBase II	\$249	13%
Quickscreen for dBase II	\$129	13%
dBASE for dBase II	\$75	25%
Infocom, Deadline, B*	\$45	25%
Zork II, B*	\$39	25%
Innovative, Spellguard, B*	\$220	25%

**\* Insolt, Accountant, B\*** each module  
For each GL, A/R, A/P or Payroll Absolutely one of the best accounting software system available. We use it and recommend it highly. A best buy!

MicroCraft, Legal Billing & Time Keeping	\$99	45%
Pro! Billing & Time Keeping	\$395	45%
MicroPro, Wordstar, B*	\$249	40%
Dastar, B	\$199	40%
Maidmerge, B	\$79	40%
Super Sort, B*	\$150	40%
Word Master, B*	\$90	40%
Spell Star, B*	\$150	40%
Calc Star, B*	\$180	40%
Microsoft, Fortran 80, B	\$325	25%
Basic Compiler, B	\$295	25%
CoBol 80, B*	\$545	25%
Basic 80, B*	\$275	25%
Feachtree, Magic Wand, B*, Word Processor	\$275	30%
GL, A/R, A/P, PR or Inventory, B*	\$325	35%



### HEWLETT PACKARD

* H/P 85A Microcomputer/Monitor/Printer	Special	\$1795	36%
H/P 87A CP/M Microcomputer	Special	\$1795	29%
* H/P 125 CP/M Microcomputer	New	\$1965	30%
H/P 87901M 5" Dual Drives		\$1595	28%
H/P 7225B Professional Graphics Plotter	Special	\$1795	35%
* H/P 7470A Graphics Plotter	New	\$1125	28%
* H/P 8290B Serial Printer	Special	\$850	50%
H/P 41C Calculator		\$185	25%
H/P 41CV Calculator 2.2K		\$245	25%
Card Reader for HP41		\$159	27%
Printer/Plotter for HP41		\$289	25%
Optical Wand for HP41		\$89	25%

**Software:**

Visicalc + for HP87	\$189	25%
Visicalc + for HP125	\$159	20%
* Accountant by Insolt for HP125	\$99	

For each GL, A/R, A/P or Payroll. Absolutely the best HP125 accounting software we have seen. We use it and recommend it highly. A best buy!

Full line of HP accessories and software Call Call



### VIC 20 Home Computer

Datasette VIC 1530	\$59	20%
Disk Drive VIC 1540	\$479	SAVE
Super Expander VID 1211A 3K with lots of extras	\$56	20%
3K Memory Expander Cartridge	\$32	20%
8K Memory Expander Cartridge	\$48	20%
16K Memory Expander Cartridge	\$88	20%
VIC Modem, Telephone Interface	\$96	20%
VIC/IEEE-488 Interface	\$80	20%
Joystick	\$8	20%
Game Paddle Pair	\$15	20%

Software full line in stock. Call

### ATARI

800 Computer 16K	\$685	38%
400 Computer 32K	\$747	37%
300 Computer 48K	\$777	40%
400 Computer 16K	\$225	25%
810 Disk Drive	\$444	26%
850 interface	\$159	25%
410 Recorder	\$79	21%
820 Printer 40 Col Impact	\$269	14%
822 Printer 40 Col Thermal	\$279	14%
830 Acoustic Modem	\$159	28%
16K RAM	\$85	15%
32K RAM	\$109	20%
Le Stick by Datasoft	\$29	28%
Game Paddles (pair)	\$18	20%
Joystick (pair)	\$18	20%

**SOFTWARE**

Visicalc, Disk	\$189	25%
Word Processing, Disk	\$119	23%
Pacman, Cart	\$35	22%
Compoze, Cart	\$35	22%
Careers of Mars, Disk	\$11	23%
Touch Typing, Tape	\$19	23%
Personal Financial Mgt, Disk	\$55	22%
Entertainer KA, Cart	\$79	33%
Educator KA, Cart	\$125	29%
Programmer Kit, Cart	\$56	22%
Communicator Kd, Cart	\$335	26%
Dow Jones Invest Disk	\$99	24%
Temple of Apshai by Automated, Disk	\$29	25%
Apple Panic by Broderbund, Disk	\$23	25%
Raster Blaster by Budgetco, Disk	\$23	25%
Bug Attack by Cavaker, Disk	\$23	25%
Text Wizard by Datasoft, Disk	\$75	25%
Compu-series by EduWare, Disk	Call	25%
Deadline by Infocom, Disk	\$37	25%
Zork II by Infocom, Disk	\$29	25%
Asteroid by On Line, Disk	\$20	25%

## CORVUS SYSTEMS

6 Meg Hard Disk	\$2495	20%
11 Meg Hard Disk	\$3995	20%
20 Meg Hard Disk	\$4795	20%
Mirror built in for easy backup	\$649	20%
Apple Interface	\$239	20%
Apple III Interface (ISDS)	\$239	20%
IBM PC Interface (IBM DOS)	\$239	20%
Xerox Interface (CP/M)	\$239	20%
NEC Interface (CP/M)	\$239	20%
TRS 80 Interface (call)	Call	20%

Other interfaces, Omni-Net, Constellation Mirror. All in Stock.

### NEC 8001 32K Computer

\$739	25%	
286K Total, Dual Drive PC8011	\$739	25%
32K add-on and I/O Unit PC8012	\$485	25%
Ren Tec 'The Wedge' 32K	\$495	17%
8023 Impact Printer F/I	\$480	25%
Impact Printer Cable	\$49	25%
3510 Letter Quality Daisy Wheel Printer	\$1995	20%
Monitor, 12" Green	\$159	25%
Monitor, 12" Color	\$349	25%

**Software:**

NEC CP/M DOS for NEC 8001	\$115	25%
NEC Report Manager	\$135	30%
NEC General Accounting	\$239	40%
NEC Accounts Receivable	\$239	40%
NEC Inventory System	\$239	40%
NEC Payroll System	\$239	40%
NEC Game Pack I	\$24	20%
NEC Game Pack II	\$24	20%
NEC Word Processor	\$395	20%
Infocom, Zork II	\$28	25%
Deadline	\$39	25%

**Insolt, Accountant**  
For each GL, A/R, A/P or Payroll Absolutely the best NEC accounting software we have seen. We use it and recommend it highly. A best buy! \$99

## μ-SCI MICRO-SCI FOR THE APPLE II/II+ DIRECT SUBSTITUTES FOR APPLE DRIVES

Micro-Sci A2 drives and/or controllers are direct plug compatible substitutes for Apple drives and controllers. A2 will run all Apple software. Save over \$350 on an A40 or A2 dual drive system. We use them and highly recommend the product.

* A2 5 1/4", 143K Disk Drive	\$369	23%
Controller Card for A2 Drive	\$79	21%
A40, 5 1/4", 160K Disk Drive	\$359	20%
A70 5 1/4", 286K Disk Drive, Double Density	\$479	20%
Controller Card for A40 or A70 Drive	\$79	21%
Flier, Disk Utility Software System for A2 Drives	\$15	25%

## OVERSTOCK SPECIAL for the APPLE II/II+

ALS 16K AddRAM Card	\$59	60%
ALS ZCard, Z80 CP/M Card	\$199	27%
ALS Smarterm 80 Col Card	\$229	34%
ALS Synergizer Pack	\$450	40%
ALS Synergizer Pack with Supercalc by Sorcum (while they last)	\$495	53%

## PRINTERS, Daisy Wheel

* Qume, Sprint 9, 45 Cps RD	SPECIAL	\$1750	33%
Sprint 5, 45 Cps RD	SPECIAL	\$1795	40%
* Olympia (Typewriter/Printer) ES 100 18CPS, with full cable and interface to Apple II		\$1295	24%

## PRINTERS, Impact

Epson See Epson section below	See below	
IDS, Prism 132 Color w/Graphics	\$1595	26%
Prism 80 Color, w/Graphics	\$1495	17%
Pager Tiger 442L, w/Graphics & 2K	Special	\$595 35%
Pager Tiger, 560, w/Graphics		\$995 30%
Dhrdata, Microline 82A, 120 Cps 80 Col Para & Serial		\$495 15%
Microline 84S, 200 Cps 136 Col Serial, 200 Cps		\$1295 15%

## EPSON PRINTERS & ACCESSORIES

MX80 w/Graphics	\$425	31%
Mx80 F/I w/Graphics +	\$525	25%
MX100 F/I w/Graphics +	\$695	27%
Apple Interface and Cable for MX80/MX100	\$95	15%
Graphics 80 for MX80	\$79	20%
Epson/Atari Cable	\$30	26%
Epson TRS 80 Cable	\$30	26%
Graphic by Orange Micro, Speedy Computer	\$129	21%

## MONITORS

NEC, 12" Green	\$159	25%
12" Color, Composite	\$349	25%
Sanyo, 9" B&W	\$149	25%
* 9" Green, Overstock Special	\$139	36%
12" B&W	\$199	20%
12" Green	\$199	25%
13" Color Composite	\$349	25%
Zenith 12" Green	\$119	30%
Amdek, 12" Green #300	\$159	38%
13" Color I, Composite	\$359	20%
13" Color II, RGB	\$799	20%
Color II to Apple II Interface	\$159	20%
Comtec, 13" Color, Composite	\$349	27%
13" Color, RGB for IBM-PC	\$529	15%

## DISKETTES

**\* CDC 12 for 10 Special, Limited Time!**

CDC, 120 each 5 1/4" with ring, SS, SD (Apple IBM, etc.)	\$195	57%
12 each 5 1/4" with ring, SS, SD (Apple IBM etc.)	\$22	45%
12 each 5 1/4" with ring, SS, DD (H/P etc.)	\$28	45%
12 each 8" SS, SD	\$28	45%
Verbatim, 10 each 5 1/4", with ring SS, SD	\$28	45%
Maxell, 10 each 5 1/4", SS, SD	\$35	33%
Dynan, 10 each 5 1/4", SS, SD	\$39	30%
10 each 5, DS, DD	\$49	25%

**ORDERING INFORMATION AND TERMS:** We ship immediately on Cashier Checks, Money Orders, Fortunes, 1000 Checks, and Government Checks. Personal Checks and Company Checks allow 20 days to clear. Add 3% for VISA or MC. Add 3% for shipping, insurance and handling (minimum \$5). UPS ground is standard. Add 10% more for US Postal, APO or FPO. Include telephone no. No COD. Prices subject to change and typographic errors, so call to verify. All goods are new, include factory warranty, and are guaranteed to work. Due to our low prices all sales are final. Call before returning goods for repair or replacement. ORDER DESK HOURS: 8 to 6 P.M. M-F 10 to 4 Sat & Sun 1 p.m. here 4 p.m. in NY

**OUR REFERENCES:** We have been a computer dealer since 1978 and in mail order since 1980. Banks: First Interstate Bank, (503) 776-5620 and Jefferson State Bank, (503) 773-5333. We belong to the Chamber of Commerce, (503) 772-6293, or call Dun & Bradstreet if you are a subscriber. Computer Exchange is a division of O Tech Group, Inc.

Portland, OR, Cash & Carry Outlet  
11507 D SW Pacific Hwy., Pacific Terrace Shop Ctr., Tigard, OR Over-the-counter sales only. On 99W between Rte. 217 and Interstate 5. Call 245-1020

**NO SALES TAX** Oregon Order Desk (503) 772-3803 NATIONAL ORDER DESK TOLL FREE (800)547-1289 Ad #937 Circle 106 on inquiry card.

# Professionals

Manufactured Exclusively for  Bell & Howell by  apple computer

	LIST PRICE	OUR PRICE	SAVE
B&H Apple II+			
64K (48K + ALS 16K)	\$1725	\$1195	\$530
DISK II w/3.3 Cont.	\$645	\$520	\$125
DISK II Only	\$525	\$450	\$75

**OR: SAVE OVER \$350 on a pair of drives.**  
Buy a pair of Micro-Sci A2 Drives.  
See opposite page.

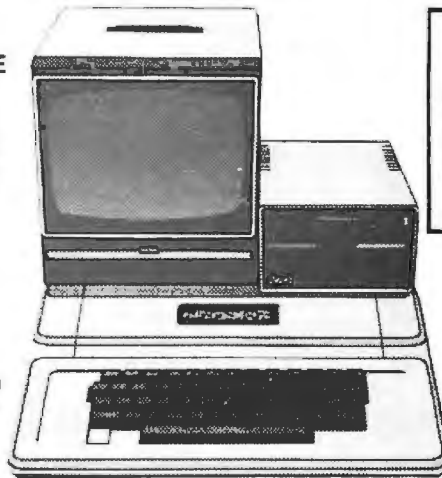

**SPECIAL**

**B & H APPLE II+ 64K STARTER SYSTEM** **\$1,795**  
**SAVE \$ 765**

- 48K B&H Apple II+
- ALS 16K RAM Card
- Disk II with 3.3 DOS & Controller
- Sanyo 9" Green Monitor

Add \$60 for Apple Beige color.  
Save \$832 total. Substitute a A2 Micro-Sci drive for the Disk II.  
Add another A2 drive and save a total of \$888.

**B & H APPLE II+ 64K BUSINESS STARTER SYSTEM** **\$2,240**  
**SAVE \$1,125**

Starter System above plus:

- ALS ZCard, Z80 CP/M Card
- ALS Smarterm 80 Column Card
- Sorcim Supercalc (while they last)

**apple II/II+ supply center**

## HARDWARE for Apple II/II+

MICRO-SCI. Disk Drives Plug software compatible to Apple. See opposite page

**RAM CARDS**

MicroSci. 16K RAM Card	\$ 149	33%
ALS. 16K ADDRAM	\$ 59	60
Saturn Systems. 32K	\$ 169	25%
64K	\$ 319	25%
128K	\$ 459	25%
VC Expand 40 or 80	\$ 75	25%
Aston. 320K RAM Disk system	\$1145	20

**80 COLUMN VIDEO CARDS:**

ALS. Smarterm	\$ 229	34%
Video V decoder	\$ 249	28
See more ALS and Video under Miscellaneous		
Vista. Vx100 80	\$279	30
M&R. Sup R term	\$ 319	15

**MISCELLANEOUS:**

ALS. Smarterm 80 Col Card Special	\$ 229	34%
Z Card (Z80) W CPM Special	\$ 199	27%
16K ADDRAM Special	\$ 59	60
Synergizer Pac Special	\$ 450	40

**Apple Computer.**

Sanyo 9" II Printer	\$ 335	15
Graphics Tablet	\$ 675	15
JoyStick II	\$ 39	22
Game Paddle	\$ 19	27
Numeric Keypad	\$ 119	21
Aston. 320K RAM Disk System	\$1145	20
CCS. Serial Interface 7710A	\$ 139	22
Other CCS Cards in stock		Call
Dan Paymar Lower Case Chips	\$ 34	33
Hayes. Micromodem II	\$ 289	25
Smallmodem	\$ 229	20
ISC. Videotek Paddle	\$ 35	23%
Kennington. System Saver Fan	\$ 75	20%

**Keyboard Company**

JoyStick I	\$ 39	22%
Game Paddle	\$ 19	27%
Numeric Keypad	\$ 119	21%
M&R. RF Modulator	\$ 25	27
Suprifan	\$ 39	25

**Microsoft**

Z80 Softcard	\$ 269	33
16K RAM Card	\$ 149	33
Softcard Premium Pack	\$ 579	25

**Mountain.**

CPS Multifunction Card	\$ 209	13
C... Calendar	\$ 195	30

**Novation. Applecat Modem**

Orange Micro. Grappier	\$ 129	21
------------------------	--------	----

**Practical Peripherals. w/cable & Conn)**

MBS 8K Serial (Epson)	New	\$ 129	20%
M&P 16K Para (Epson)	New	\$ 129	20%
Microbuffer II 16K	New	\$ 209	20%
Microbuffer II 32K	New	\$ 229	24%

**RH Electronics. Super Fan II**

SSM. A10 Serial/Para Interface	\$ 159	20
16 Products. Game Paddles	\$ 29	28
Joy Stick	\$ 45	25
Soft Vides. SMI-II	\$ 249	28
Er... ..	\$ 25	29
Fr... ..	\$ 99	34
Fr... ..	\$ 99	26
Fr... ..	\$ 99	25
Full Video Line	Call up to 35	

## SOFTWARE on disk for Apple II/II+

### BUSINESS

Apple Computer, Inc. 50% Off on Apple II Software	Ca	50	
The Controller (Accounting)	\$499	20	
Apple Writer I I	\$ 59	20	
Apple Pascal	\$199	20	
Apple Fortran	\$159	20	
DOS Tool Kit	\$ 59	20	
DDOS 3.3 Upgrade Kit	\$ 59	20	
Apple Plot	\$ 59	20	
DJ News & Quotes	\$ 75	20	
DJ Portfolio Evaluator	\$ 45	20	
How to	\$ 39	20	
Macrowriter	\$199	20	
Micro Telegram	\$199	20	
Time Manager	\$119	20	
Many			
Applied Soft Tech Ver 1 Form	\$289	26	
Artex Mag. W. dow	\$ 75	25	
Ashon-late dBase II (LP M)	\$495	30	
Beagle Bios. UT b... ..	\$ 25		
Broderbund Payro	\$269	3L	
Continental CPA #1	\$349	25	
CPA #2 Account Re	\$189	25	
CPA #3 Account Pay	\$189	25	
CPA #4 Payroll	\$189	25	
CPA #5 Property Mgt	\$189	25	
Denver. Financial Partner	\$185	25	
dBase II for Apple II/II+ CP/M	\$495	30	
For & Geller. QuickScreen for dBase II	\$129	13	
Quickcode for dBase II	\$259	13	
Hayden Pie Writer (Specify brd)	\$125	25	
H&N Trading. Stock Tracker	\$179	32	
Market Tracker	\$199	33	
High Tech Store Mgt	\$189	25	
Job Control Sys	\$469	40	
Info Master	\$119	40	
Info Union Easywriter (P/M)	\$139	25	
Innovative. Spellguard (CP/M)	\$150	50	
Inssoft. Accountant (CP/M)	\$ 99		
For each GL A/P A/P or Payro. Absolute: the best accounts software available for the Apple II+ Better than Peachtree. We use it and recommend it.			
LJK. Letter Writer I	\$112	25	
ICP M. Legal Billing & timekeeper	\$250	65	
Prof Billing & timekeeping	\$250	65	
Micro Lab Data Facility (user S J)	\$249	20	
Vi factory	New	\$ 56	2
Invis v Factory	\$129	35	
Tax Manager	\$ 95	38	
Micro Pro (all CP/M)		SAVE	
Word Star NewVersion	\$199	47	
MainMeger	\$ 69	45	
SpeeStar	\$119	40	
DataStar	\$169	40	
Superbit II II	\$159	40	
Muse	\$11	25	
Super Text 4E 8J	\$129	25	
Fr... ..	New	\$ 15	5
On-Line			

Osborne C.P. Soft. (Disk and Book)			
Some Common Bas. Programs	\$ 49	50%	
75 Bas. Status and Math program for the Apple II			
Practical Bas. Programs			
40 very valuable programs by Some Com Basic Prog	\$ 49	50%	
Peachtree. GL AR AP or Inv each	\$189	36%	
★ Magic Wand (Specify board)	\$250	50%	
Phoenix Zoo Grahs	\$ 29	28%	
Sensible. Apple Speller	\$ 55	27%	
Silcon Valley. Word Handler	\$150	40%	
Solidus/Softech			
★ Stocks	\$250	60%	
★ Stocks	\$425	40%	
Software Publishing			
PS II NEW version	\$ 89	30%	
PF Report II or III	\$ 69	30	
Sorcim. Super Calc (CP/M)	\$219	25	
Southeastern			
Data Capture 4.0 specify brd	\$ 69	25	
Source Source	\$ 75	25	
Stoneware DB Master	\$179	22	
Stoneware DB Mity I	\$ 75	10%	
VisiCorp/Personal Software.			
Vivacut 3.3	\$189	25%	
VidEx Special	\$175	30%	
Ver 4.0	\$199	25%	
De King Plan II or III Special	\$175	30%	
Vid 4.0	\$159	20%	
V module	New	\$239	20%
Vistrend and VisiPlot Special	\$210	30%	
Term	\$ 79	20	
Zark	\$ 33	20	

### UTILITY & DEVELOPMENT

Beagle. Utility City	\$ 22	25	
DOS Boss	\$ 18	25	
Central Point Software:			
Film DGS Utility	\$ 18	25	
★ Copy II (copy copier)	\$ 35	10	
W... .. copy protected software for your backup in 45 seconds or less! Highly recommended			
Epson Graphics Dump	\$ 9	35	
Inssoft.			
★ IIFORTH by Paul Lutus	New	\$ 59	22
ALD System II by Paul Lutus	\$ 59	22%	
Tr IIFORTH by Paul Lutus	\$ 99	20	
Electric Duet by Paul Lutus	New	\$ 25	20
Microsoft.			
ALD S	\$110	10	
BASIC Compiler	\$299	25	
Final 80	\$559	25	
Final 80	\$149	25	
Olympic Graphical	\$ 24	28	
TASC Compiler	\$159	22	
Compiler	\$ 75	25	
★ Omega. (Specify board)	\$ 75	25	
On-Line. Expedite II	\$ 75	25	
Phoenix. Econ Grahs	\$ 29	28	
Source. the Source	\$ 75	25	
Southern. ASCII Express	\$ 59	25	
Sub-Logic. Flight Simulator	\$ 28	20	
Tymac. (Specify Pa)	\$ 20	20	

Warranty: Factory warranty is by Bell & Howell (not by Apple) and is one year parts plus 90 day labor. Warranty service available at Bell and Howell service centers or return to Computer Exchange.

Apple is a registered trademark of Apple Computer Inc.

★ Means a BEST buy.

### HOME & EDUCATION

Autom. Sim., Crush Crumb Clump	\$ 30	25%	
Broderbund:			
Apple Panic	\$ 21	30%	
Arcaide Machine	\$ 32	30%	
Red Alert	\$ 21	30%	
Space Marine	\$ 18	30%	
Star Blazer	New	\$ 24	30%
Many others	Call	Call	
Budgeco. Raster Blaster	\$ 22	27%	
Calif Pacific. Ultima	\$ 30	25%	
Cavalier. Bug Attack	\$ 23	23%	
Continental. Home Accountant	\$ 56	25%	
Home Money Manager	\$ 26	25%	
L.A. Land Monopoly	\$ 23	25%	
DataMast. Snack Attack	\$ 22	25%	
Thwei	\$ 22	25%	
EduWare. Compumath	\$ 29	25%	
Hayden. Sargon II (Chess)	\$ 29	22%	
Infocore. Endline	New	\$ 38	25%
Zork	\$ 29	25%	
Inssoft. Electric Duet by Lutus	New	\$ 25	20%
Graph II by Lutus	New	\$ 59	25%
Lightning. Masterbyte	\$ 29	25%	
Microsoft. Olympic Decathlon	\$ 24	24%	
Typing Tutor	\$ 19	30%	
Muse. Robot War	\$ 29	25%	
On-Line. Pegasus II	\$ 22	25%	
Mousystick	New	\$ 26	25%
Time Zone	New	\$ 75	25%
Jambreaker	New	\$ 23	25%
Ultima II	New	\$ 27	25%
Warader	New	\$ 26	25%
Threshold	\$ 20	25%	
Clanston Manor	\$ 26	25%	
Mission Astroid	\$ 15	25%	
Mystery House	\$ 19	25%	
Softporn (K Rated)	\$ 22	25%	
Ulysses and Golden fleece	\$ 22	25%	
Piccadilly. Falcon	\$ 23	25%	
Star Blaster	\$ 23	25%	
Sentient. Do-TOPODS	\$ 25	25%	
Serios. Sneakers	\$ 22	25%	
Gorgon	\$ 29	25%	
Tweeps	\$ 22	25%	
Sir-Tec. Wizardry	New	\$ 39	22%
Strategic. Southern Command	\$ 30	25%	
OTHER BRANDS IN STOCK. CALL			

THE WORLD'S LARGEST COMPUTER MAIL ORDER FIRM

# Computer Exchange

A Division of **OTECH**

ALL MAIL: P.O. Box 1380, Jacksonville, OR 97530

WAREHOUSE AND OFFICES BY APPOINTMENT AT 6791 UPPER APPLGATE ROAD

Ad #937

### International Morse Code

A	.-	W	...-
B	...-	X	...-
C	...-	Y	...-
D	...-	Z	...-
E	.	1	....-
F	....	2	....-
G	...-	3	....-
H	....	4	....-
I	..	5	....-
J	....	6	....-
K	...-	7	....-
L	....	8	....-
M	--	9	....-
N	..	0	....-
O	---	.	(period) ....-
P	...-	;	(semicolon) ....-
Q	...-	:	(colon) ....-
R	...-	,	(comma) ....-
S	...-	?	(question mark) ....-
T	--	'	(apostrophe) ....-
U	...-	-	(hyphen) ....-
V	....	/	(fraction bar) ....-

### Additional Codes

space bar	....-
backspace	....-
carriage return	....-
escape (OE)	....-
control (KS)	....-
right arrow (UU)	....-
repeat (HM)	....-
! (exclamation point)	....-
\$ (dollar sign)	....-
* (asterisk)	....-
+ (plus sign)	....-
= (equals sign)	....-
" (quotation marks)	....-
( (open parenthesis)	....-
) (close parenthesis)	....-
{ (ampersand)	....-
# (number or pounds)	....-
% (percent)	....-
(exponent)	....-
@ (at)	....-
< (less than)	....-
> (more than)	....-

**Table 2: Signals for the Morse-code input routine.** The Morse-code input routine uses standard International Morse code and a number of additional codes to allow full access to the Apple II. (Adapted from "EMG Activated Spatial Morse Code General Purpose Communication Device" by Carl B. Friedlander and Morteza Rahimi. Proceedings of the IEEE Conference on Frontiers of Engineering in Health Care, Denver, Colorado, October 6-7, 1979; page 298.)

firmware card will be entered into the computer as if it had been typed on the keyboard. The firmware card will support data rates of 110, 150, 300, 600, and 1200 bps (bits per second). Note that, because a DB25 connector is used for several things, the standard RS-232C pin assignments are not used.

In the *expanded-keyboard* mode, the card will support any 8- by 15-switch matrix.

### Special Options

The options available with the firmware card include the *slowdown* option, which allows any program being executed on the computer to be slowed down for use by individuals having slower reaction times. This is accomplished by interrupting the program and inserting delay loops. Because these interruptions are actually triggered by the structure of the program itself, the effect of the slowdown value (which can be from 0 to 255) varies from program to program. Experimentation with individual programs will determine the best value for the given individual and program. (The default value is 0.)

The *paddle* option allows you to use a single switch instead of a paddle to play games that use game paddle 1. When selecting a paddle mode, you indicate a parameter that tells the program which of seven paddle

where that is required.)

When the *parallel* mode is selected, the adaptive-firmware card acts as a straight keyboard emulator. Any parallel ASCII (American Standard Code for Information Interchange) fed to the firmware card through a

parallel port will be entered into the computer as if it had been typed on the keyboard.

In the *serial* mode, the firmware card again acts as straight keyboard emulator, accepting serial ASCII data. Any serial ASCII fed to the

Micro MidWest  
10205 West 69th Terrace  
Merriam, KS 66203  
Call: (913) 362-3462

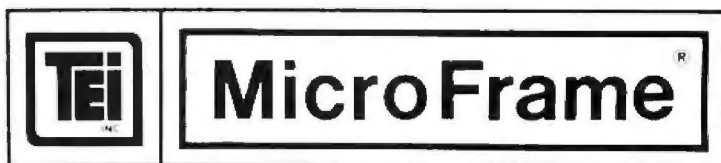

110 V 60 Hz CVT S-100 bus (IEEE-696) Microframes and disk enclosures. Constant Voltage Transformer (CVT) instantly regulates AC power ranging from as low as 50VAC to as high as 140VAC (depending on the current load) to with  $\pm 3\%$ . TEI microframes gives you lots of good clean power. 90 day factory warranty. With TEI you don't need an expensive voltage regulator; TEI isolates your boards and drives from spikes, voltage variations, noise and even brownouts.

12 slot microframes  $\pm 8V @ 17A$ ,  $\pm 16V @ 2A$   
22 slot microframes  $\pm 8V @ 30A$ ,  $\pm 16V @ 4A$

		List	Our Price
MCS-112	12 Slot Table Top Microframe	\$755	\$645
MCS-122	22 Slot Table Top Microframe	\$910	785
RM-12	12 Slot Rack Mount Microframe	\$800	795
RM-22	22 Slot Rack Mount Microframe	\$965	850

8" disk drive enclosure with CVT Holds two 8" Shugart 801R or 851 R, or Qume DT-8 size drive. +24V @ 1.5A, +5V @ 1.0A, -5V @ 0.24A. Power cables included

DFD-0	Table Top Disk Enclosure	\$565	\$500
RFD-0	Rack Mount Disk Enclosure	\$725	625

Combination of S-100 bus and disk enclosure. 12 slot bus plus 3 cutouts for 5 1/4" floppy disk drives (or 5 1/4" size hard disks) +8V @ 17A,  $\pm 16V @ 2A$ , +12V @ 1.2A. Power cable included

TF-12	Table Top Combination	\$745	\$650
RF-12	Rack Mount Combination	\$855	750

Inventory In Stock! Dealer inquiries invited: We are a TEI (Texas Electronic Instruments) Master Distributor

Terms: COD accepted. 2% discount on Prepaid orders. Kansas Residents add 4% sales tax. All prices subject to change. We normally use UPS. Blue Label or other fast shipment available at purchaser's choice.

# Your guide to the world of microprocessors.

## The Micro-Professor™ - A low cost tool for learning, teaching and prototyping.

Here in one attractive package and at a price of only \$149.00 is a Z80\* based microcomputer to lead you step by step to a thorough knowledge of the world of microprocessors.

The Micro-Professor is a complete hardware and software system whose extensive teaching manual gives you detailed schematics and examples of program code. A superb learning tool for students, hobbyists and microprocessor enthusiasts, as well as an excellent teaching aid for instructors of electrical engineering and computer science courses.

But the Micro-Professor is much more than a teaching device. With it you can do breadboarding and prototyping, designing your own custom hardware and software applications with Z80, 8080 and 8085 compatible code.

The standard 2K bytes of RAM is expandable to 4K, and the standard 2K bytes of ROM can be increased to 8K.

All this plus a built-in speaker, a cassette interface, and

sockets to accept optional CTC/PIO. Bus is extendable.

As well as being an exciting learning tool, the Micro-Professor is a great low-cost board for OEM's. Call for details



**SSB-MPF  
Speech  
Synthesizer  
Board \$129**

A vocabulary of up to 400 words based on the TMS 5200 chip.

**EPB-MPF  
EPROM  
Programming  
Board \$169**

For all +5V 1KB/2KB/4KB EPROMs. Read/Copy/List/Verify Capability.



**BASIC-MPF  
Tiny Basic \$19**

2KB BASIC interpreter with hardware control capability. Machine-code subroutine accessible.

**PRT-MPF  
Printer  
\$99**

A thermal printer with built-in alphanumeric character patterns and Z80 disassembler. 20 characters per line, 0.8 line per second.



\* Z80 is a trademark of Zilog Inc.



**Multitech Electronics Inc.**  
30 day trial period with full refund.  
90 day warranty.

Circle 332 on inquiry card.

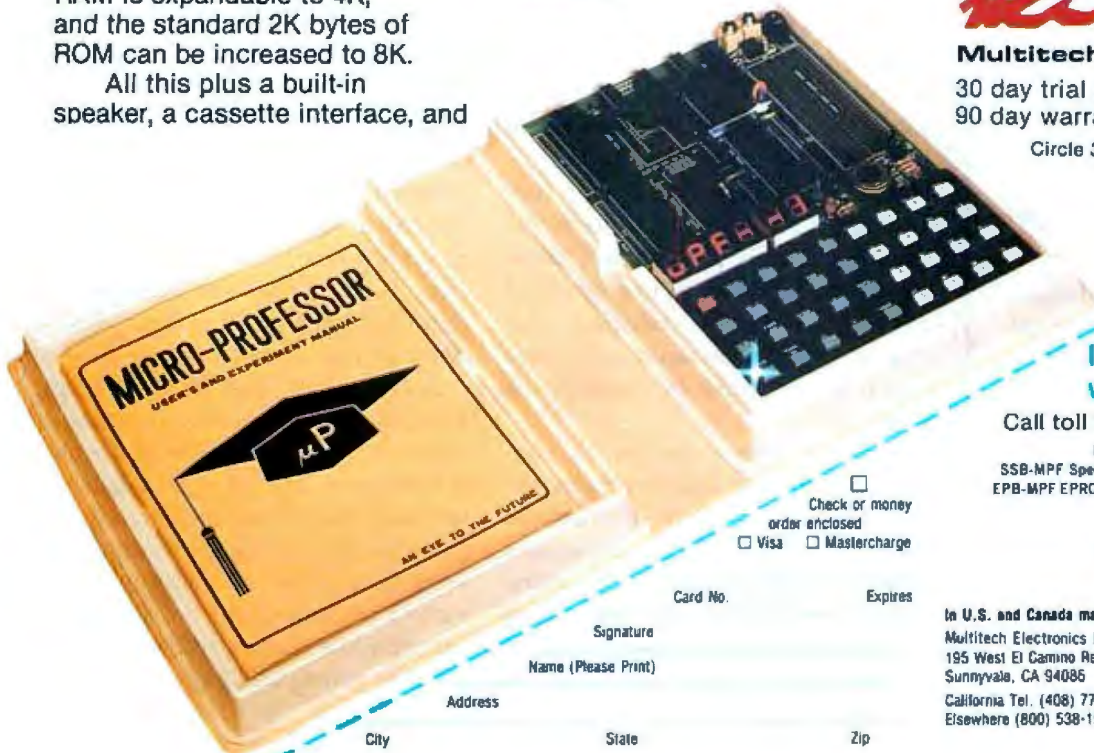

I'm ready to enter the world of microprocessing

Call toll free to order.

	Price	Qty.	Amount
MPF-I Micro-Professor	\$149.00		
SSB-MPF Speech Synthesizer Board	\$129.00		
EPB-MPF EPROM Programming Board	\$169.00		
PRT-MPF Printer	\$ 99.00		
BASIC-MPF	\$ 19.00		
Shipping and Handling	\$ 4.95		4.95
California residents add sales tax.			
<b>TOTAL</b>			

Check or money order enclosed  
 Visa  MasterCard

Card No. Expires

Signature  
Name (Please Print)

Address

City

State

Zip

In U.S. and Canada mail to:  
Multitech Electronics Inc.  
195 West El Camino Real  
Sunnyvale, CA 94085  
California Tel. (408) 773-8400  
Elsewhere (800) 538-1542

Outside of North America mail to:  
Multitech Industrial Corporation  
977 Min Shen E Road 105  
Taipei, Taiwan, ROC  
Tel 02-769-1225  
TWX 19162 MULTIC,  
23756 MULTIC

# INTEGRATED BUSSING



with the

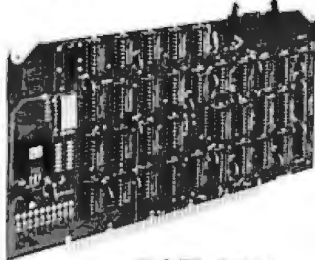

**P&T-488  
INTERFACE**

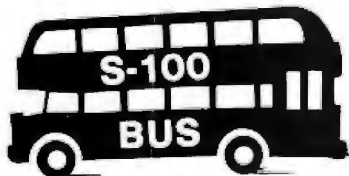

Inexpensive S-100 computers can now communicate with the IEEE-488 instrumentation bus. The P&T-488 meets the IEEE-488 1980 standard for **controller, listener, & talker**.

Interface **software** allows simple communication with the 488 bus from Basic, Pascal and other high level languages. Interface software is available for CP/M®, North Star, or Cromemco.

Special features include an interactive **busmonitor** program and a functional self-test program.

Price for (1) P&T-488 with software and 18" cable, assembled and tested: \$450 (domestic price) FOB Goleta, CA.



**PICKLES & TROUT**

P.O. BOX 1206, GOLETA, CA 93116  
(805) 685-4641

\*CP/M is a registered trademark of Digital Research

Mode	User Switch 1	User Switch 2	User Switch 3	User Switch 4
1	activates button 1	moves paddle 1 left and right		
2	activates button 1, moves paddle 1 left and right			
3	activates button 1	moves paddle 1 right only	moves paddle 1 left only	
4	activates button 1, moves paddle 1 left only	moves paddle 1 right only		
5	activates button 1, moves paddle 1 right only	moves paddle 1 left only	moves paddle 2 down only	moves paddle 2 up only
6	activates button 1	moves paddles 1 and 2 right, left, up, and down		
7	activates button 1, moves paddles 1 and 2 right, left, up and down			

**Table 3: Paddle modes.** In addition to providing an "alternate keyboard" to the Apple, the firmware card also lets you control game-paddle programs using input switches instead of paddles (and the buttons associated with the paddles). Various paddle modes are available that allow you to move the cursor back and forth on the screen using only the input switches. The table shows how paddle movement is controlled by different numbers of input switches in the different modes. You select the mode that best matches the number of switches you wish to control and the paddle requirements of the game or program you will be using.

modes should be used. (See table 3 for a summary of the paddle modes.)

In modes where one switch controls movement in two directions, holding the switch down will cause the cursor to move in one direction until the switch is released. Activating the switch again will cause the cursor to move in the opposite direction.

In modes where one switch controls movement in four directions, the routine scans through the instructions for each of the different movement directions until you hold down the switch. The routine will then carry out cursor movement according to the instruction it was on when you

pressed the switch; movement continues in this direction until the switch is released. The routine then returns to scanning around the four possible directions until you press the switch again. Thus you have the option of moving the cursor up, down, right, or left.

Seven other paddle modes are available that are exactly the same as modes 1 through 7, as far as the user is concerned, but they use a different software technique to simulate the game paddles. This allows the firmware card to be used with a greater variety of games, which use different game-paddle reading techniques.

Other game-paddle control options

# POPULAR COMPUTING

Every month *Popular Computing* will bring the latest developments in the world of personal computing — use, equipment, reviews, programs, tutorial articles — all in an easy to read style. Have *Popular Computing* delivered to your door!

## SPECIAL CHARTER OFFER!

- One year (12 monthly issues) for only \$11.97 . . . that's a \$3.03 saving on the basic rate of \$15.00, and a whopping \$18.03 saving off the newsstand rate for 12 issues. (US only, please.)
- Check Enclosed     Bill me (North America only)
- Visa     MasterCard
- Canada and Mexico (Charter Offer) \$13.97 (US Funds)
- Foreign Rates (To expedite service please remit in US funds drawn on a US bank.) Europe and all countries except above. One year (12 issues) surface delivery \$21.00.



---

Card Number

Expires

---

Signature

---

Name (please print)

---

Street/Apartment Number

---

City

State/Country

Postal Code



NO POSTAGE  
NECESSARY  
IF MAILED  
IN THE  
UNITED STATES

**BUSINESS REPLY CARD**

FIRST CLASS PERMIT NO. 45 Martinsville, NJ

POSTAGE WILL BE PAID BY ADDRESSEE

**POPULAR**  
**COMPUTING**

Subscription Department  
P.O. Box 307  
Martinsville, NJ 08836





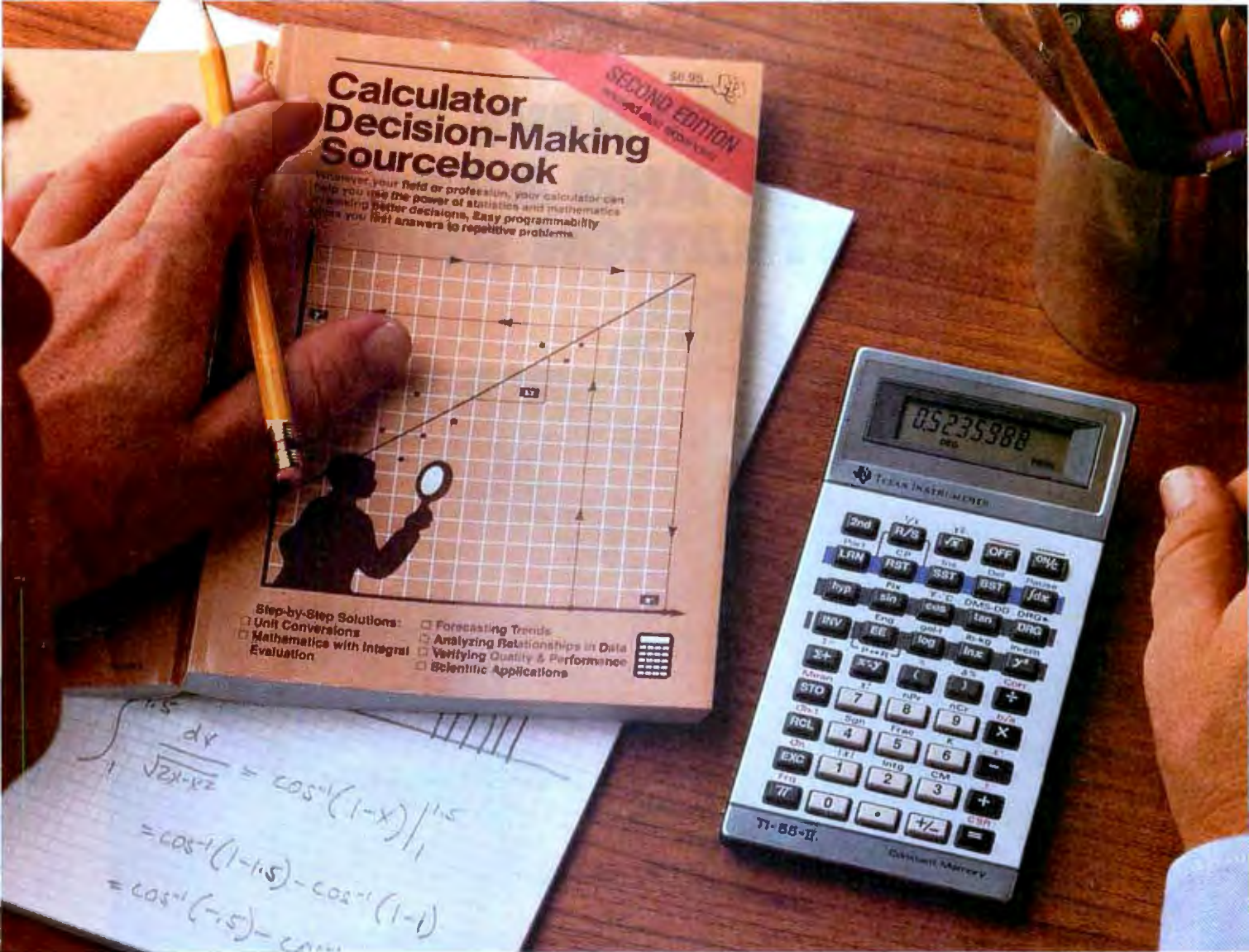

# How the TI-55-II makes short work of long problems.

Whenever you can solve complex problems quickly and accurately, you're ahead of the game. And that's exactly what the TI-55-II does for you. By giving you 112 pre-programmed functions (like definite integrals), it allows you to take short cuts without losing accuracy. You'll accomplish a lot more in less time which means increased efficiency.

With our TI-55-II you can tackle problems you thought could only be solved with higher-priced programmables. You're not only getting the standard slide rule functions but also statistical capabilities. This way you can work out linear regressions, permutations and combinations, just to name a few.

The TI-55-II also gives you enough programmability to eliminate a lot of repetitive key punching. Our Constant Memory™ keeps programs and data on tap, even when the calculator is turned off. So once you've entered a formula, you can simply put in the variables to get your solution. The Liquid Crystal Display shows your

answers in standard, scientific or engineering notations – clearly and precisely.

We also help you get the most out of your calculator with the Calculator Decision-Making Sourcebook. It gives you step-by-step examples of the best techniques used for solving mathematical, scientific and statistical problems. And we've included a special section on how to program your TI-55-II.

So next time you're facing another time-consuming problem, cut it down to size with the TI-55-II.



**TEXAS  
INSTRUMENTS**

© 1982, Texas Instruments Incorporated.

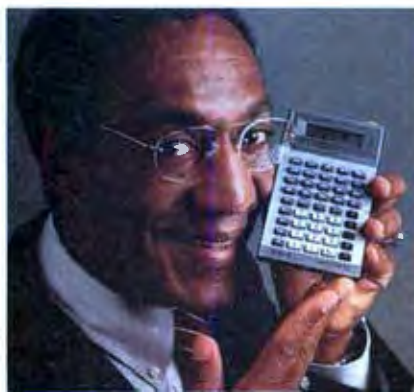

# YOU DON'T HAVE TO PAY AN ARM AND A LEG FOR DEMONSTRATION SOFTWARE!

## Get everything you need for \$295<sup>00</sup>

Whether you are selling your customer hardware or software, the three best ways to close the sale are:

1) demonstration;  
2) demonstration; and  
3) demonstration. That's why we offer you the best software demonstration system in the microcomputer industry.

The package includes all the software listed here, plus important promotional materials and our exclusive video sales presentation designed to help you make the sale. You get the whole package for just \$295.00.

We offer you the largest selection of quality business applications and the best support available anywhere. Everyone claims to be the best ... but we're willing to demonstrate it. All you have to do is give us a call, or drop us a card.

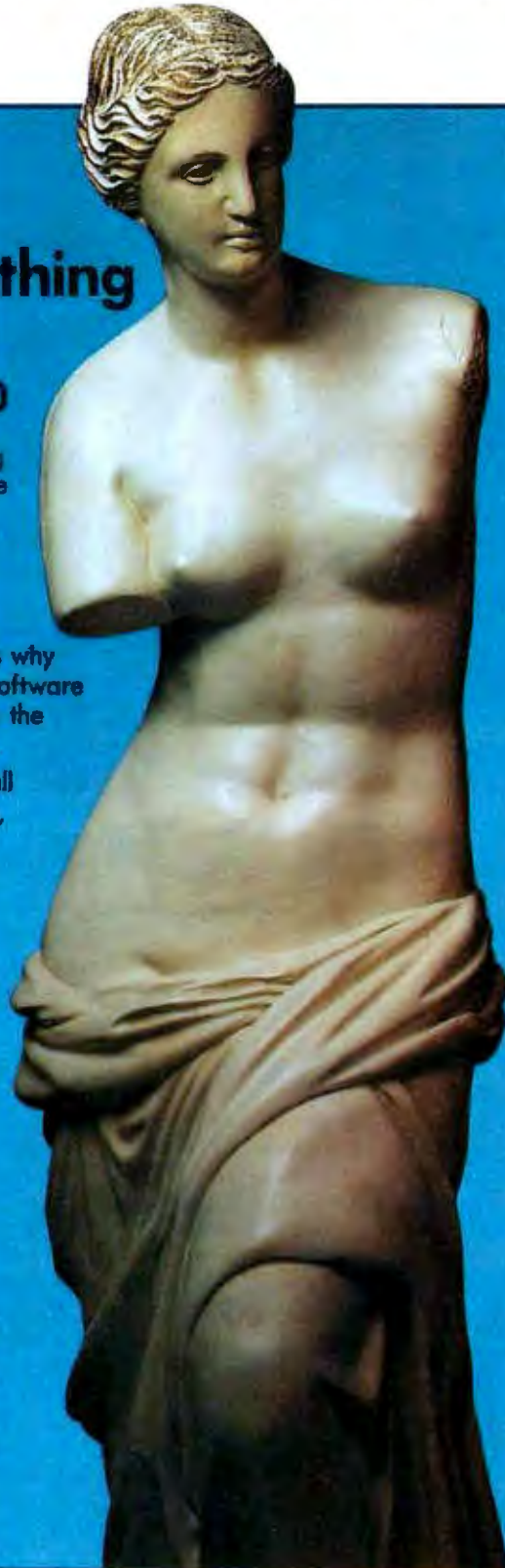

### FINANCIAL

- General Ledger • Accounts Payable • Accounts Receivable • Payroll • Cash Receipts/Disbursements • Job Costing • Mailing List Management

### MEDICAL/DENTAL

- Office Scheduler • Patient Billing • Accounts Receivable • Insurance Forms

### GOVERNMENTAL / EDUCATIONAL

- Student Record Keeping • Student Scheduling • Fund Accounting

### WHOLESALE DISTRIBUTION

- Purchasing and Receiving • Inventory Control • Invoicing and Receivables • Sales Commission Reporting • Backorder Management

### MANUFACTURING INVENTORY CONTROL

- Finished Goods Inventory Management • Parts Inventory Management • Parts Purchasing and Receiving • Bill of Material • Production Scheduling

All IMS business applications require CP/AM® or MP/AM® and CBASIC® ... registered trademarks of Digital Research Corp.



**INTERNATIONAL  
MICRO SYSTEMS**

6445 Metcalf • Shawnee Mission, KS 66202  
(913) 677-1137

may be developed. The ones above are designed to give different types of individuals using different numbers of switches maximum control of various programs.

The *paddle speed* option lets you adjust the movement speed in the game-paddle emulation routines. The speed set is equal to the number that the paddle count will be incremented (or decremented) each time the program checks for the paddle position (while the user switch is closed). The actual rate of cursor movement for any given setting will vary depending on the software being run. (Paddle speed and mode should be set before entering a game, as access to the "keyboard" input routines is restricted during game play.)

The *stop-time* option prevents your being trapped in a game-playing mode, unable to get back to the keyboard or standard input mode. Under this option, you set a stop-time delay before entering the game-playing mode. When you want to get out of

the game-playing mode, simply leave the switches inactive for the appropriate length of time, and you will automatically be returned to your special input mode.

### Technical Description

The goal in designing the adaptive-firmware card was to develop a relatively inexpensive interface that would transform the Apple II from just a computer with a keyboard into a computer with a keyboard, a scanner, a Morse-code translator, and more. Such a peripheral would either require its own microprocessor or would somehow have to steal time from the Apple for the translation tasks; thus the two approaches that suggest themselves involve either a card containing a separate microprocessor or an interrupt-driven system.

The former would have the advantage of absolute transparency. It would not, however, provide immediate access to the Apple II's memory. A separate processor could

gain access to the Apple's RAM (random-access, read/write memory) by means of DMA (direct memory access). This, however, would mean losing the simplicity of transparency, which was the original attraction of the separate-microprocessor approach. Either way, a number of problems would need to be overcome in order to provide access to all the necessary portions of the Apple without interfering with any program the computer might be running. Also, the separate microprocessor would solve each of a set of problems (which will be discussed in the following paragraphs) in essentially the same way as the interrupt-driven version but would incur the additional expense of the second microprocessor. Therefore, the interrupt approach was used. (The final design is shown in figure 1.)

### Apple II Interrupts

The Apple II has two different types of interrupts: the IRQ (mask-

*Text continued on page 299*

## Marymac INDUSTRIES, INC.

In Texas Orders  
Questions & Answers  
1-713-392-0747

22511 Katy Freeway  
Katy (Houston) Texas 77450

To Order  
1-800-231-3680  
800-231-3681

### SAVE BIG DOLLARS ON ALL TRS-80<sup>®</sup> HARDWARE & SOFTWARE

TRS-80<sup>®</sup> BY RADIO SHACK. Brand new in cartons delivered. Save state sales tax. Texas residents add only 5% sales tax. Open Mon.-Fri. 9-6, Sat. 9-5. We pay freight and insurance. Come by and see us. Call us for a reference in or near your city. Ref: Farmers State Bank, Brookshire, Texas.

### WE OFFER ON REQUEST

- Federal Express (Overnight Delivery)
- Houston Intercontinental Airport Delivery (Same Day)
- U.P.S. BLUE (Every Day)
- References from people who have bought computers from us probably in your city

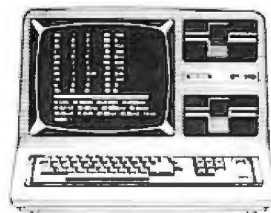

In stock TRS-80 Model II and III

No Tax on Out of Texas Shipments!

Save  
**10% 15%**

OR MORE

Reserve Your Model 16 Today

Telex 77-4132 (Flaks Hou)

### WE ALWAYS OFFER

- NO extra charge for Master Card or Visa.
- We use Direct Freight Lines. No long waits.
- We always pay the freight and insurance
- Toll free order number
- Our capability to go to the giant TRS-80<sup>®</sup> Computer warehouse 5 hours away, in Ft. Worth, Texas, to keep you in stock.

JOE McMANUS

\* TRS 80 is a Registered Trademark of Tandy Corp

ED McMANUS



Number	Type	+5V	GND	IC6	74LS30	14	7
IC1	74LS244	20	10	IC7	MW55114	18	9
IC2	74LS374	20	10	IC8	MW55114	18	9
IC3	74LS244	20	10	IC9	TBP28L22N	20	10
IC4	74LS374	20	10	IC10	74LS74	14	7
IC5	2732	24	12	IC11	7407	14	7
				IC12	74LS21	14	7

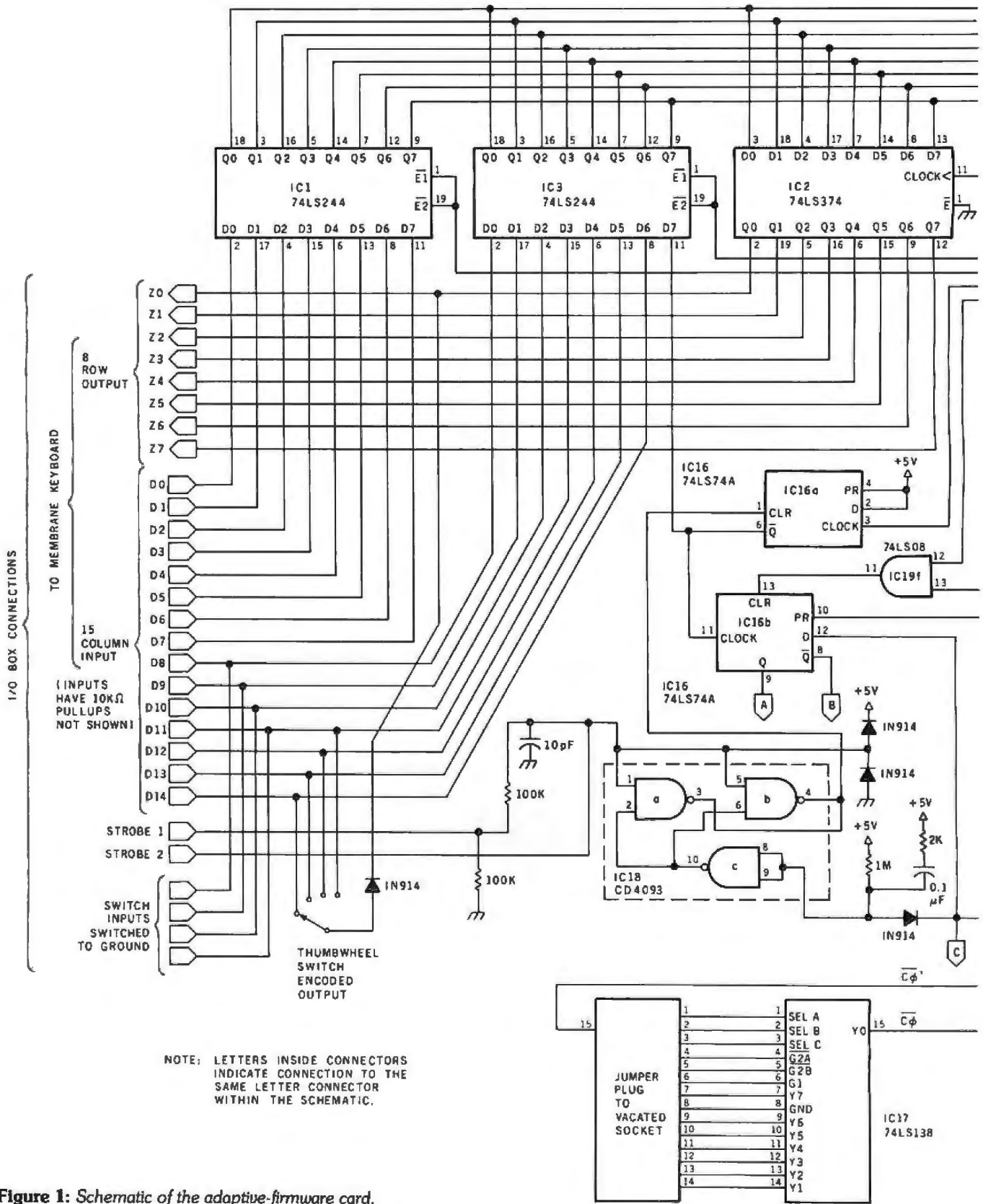
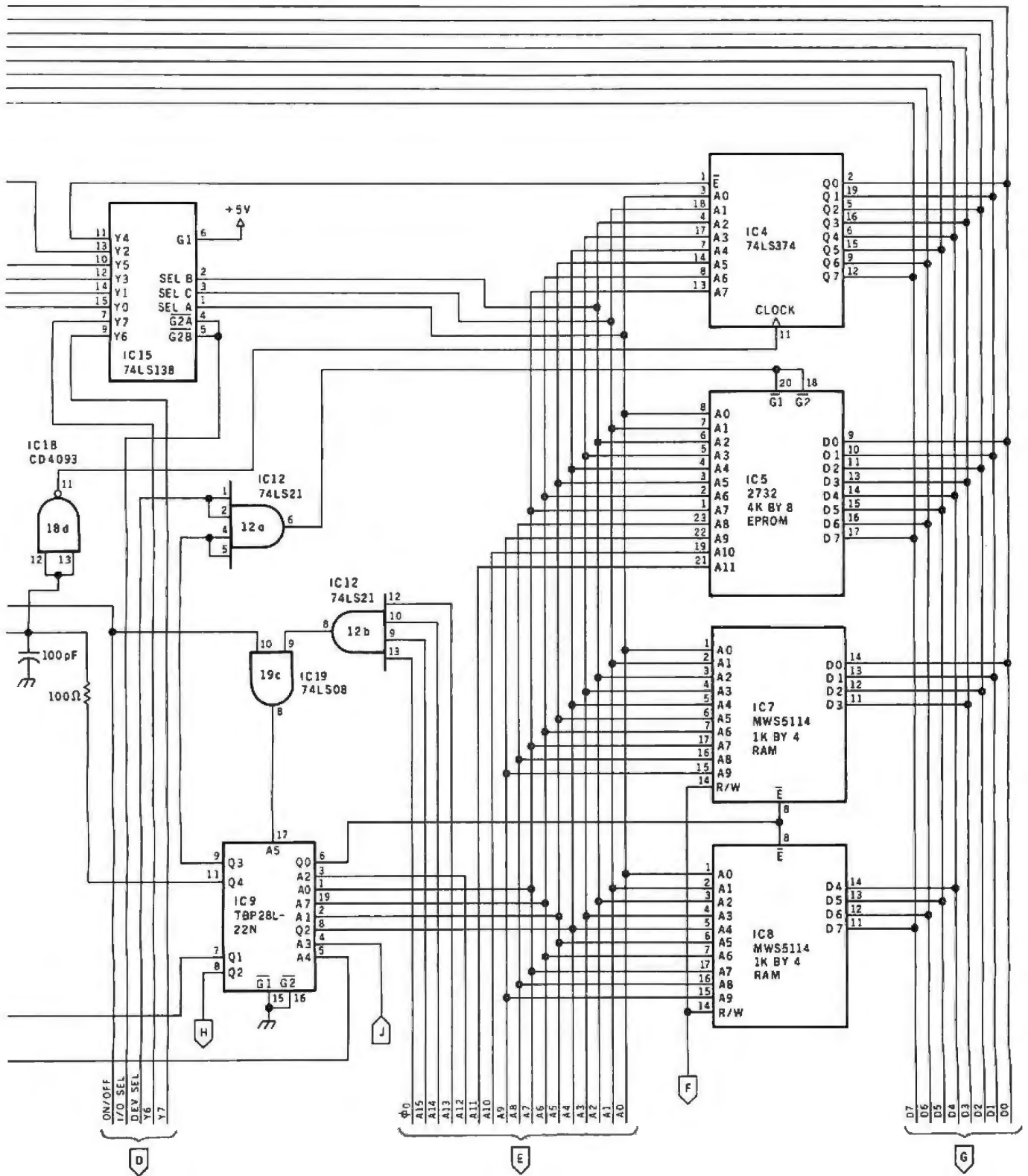

Figure 1: Schematic of the adaptive firmware card.

IC13	74LS05	14	7
IC14	74LS05	14	7
IC15	74LS138	16	8
IC16	74LS74	14	7
IC17	74LS138	16	8
IC18	CD4093	14	7
IC19	74LS08	14	7



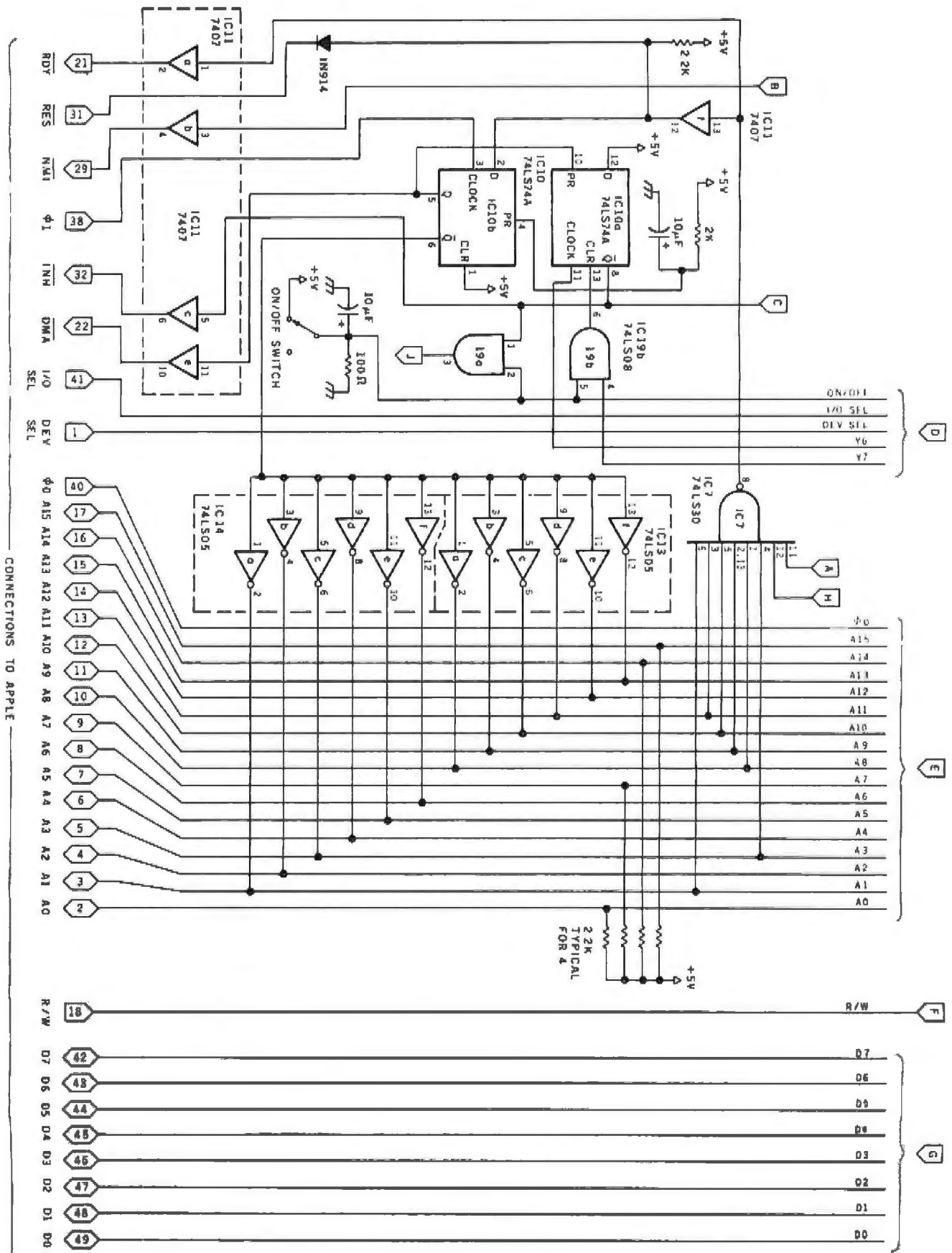

Figure 1: Schematic of the adaptive-firmware card, continued.

# WHY THE MICROSOFT RAMCARD™ MAKES OUR SOFTCARD™ AN EVEN BETTER IDEA.

Memory — you never seem to have quite enough of it.

But if you're one of the thousands of Apple owners using the SoftCard, there's an economical new way to expand your memory dramatically.

## 16K ON A PLUG-IN CARD.

Microsoft's new RAMCard simply plugs into your Apple II,® and adds 16k bytes of dependable, buffered read/write storage.

Together with the SoftCard, the RAMCard gives you a 56k CP/M® system that's big enough to take on all kinds of chores that would never fit before (until now, the only way to get this much memory was to have an Apple Language Card installed).

## GREAT SOFTWARE: YOURS, OURS, OR THEIRS.

With the RAMCard and SoftCard, you can tackle large-scale business and scientific computing with our COBOL and FORTRAN languages. Or greatly increase the capability of CP/M

applications like the Peachtree Software accounting systems. VisiCalc™ and other Apple software packages can take advantage of RAMCard too.

And RAMCard gives you the extra capacity to develop advanced programs of your own, using the SoftCard and CP/M. *Even with the RAMCard in place, you can still access your ROM BASIC and monitor routines.*

## JOIN THE SOFTCARD FAMILY.

The RAMCard is just the latest addition to the SoftCard family — a comprehensive system of hardware and software that can make your Apple more versatile and powerful than you ever imagined.

Your Microsoft dealer has all the exciting details. Visit him soon, and discover a great idea that keeps getting better.

Microsoft Consumer Products, 10700 Northup Way, Bellevue, WA 98004. (206-828-8080)

16k

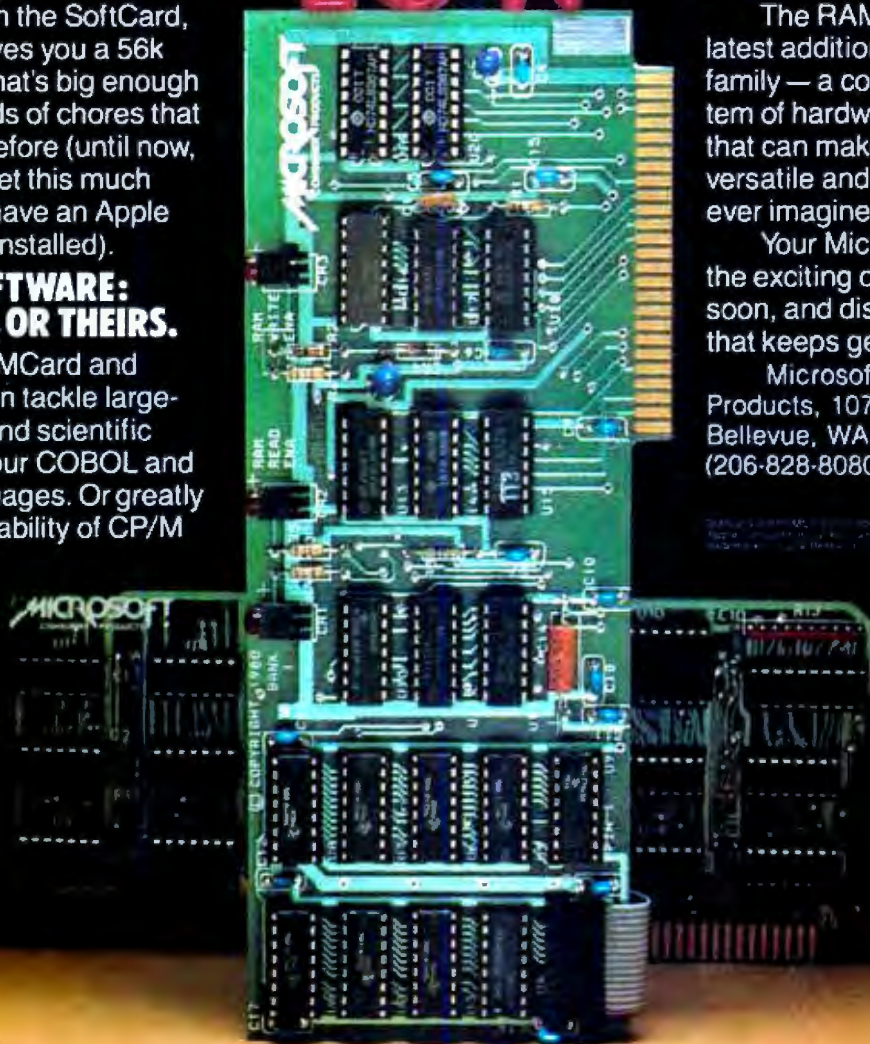

# MICROSOFT

Circle 320 on Inquiry card.

# DECIS

## The only machine that runs

**The software machine.** The Decision I™ is an IEEE 696 S-100 bus computer. But that's where its similarity to other machines ends. No other production machine offers the software flexibility of the Decision I. The Decision I runs Micronix™, which is functionally identical to the UNIX™ Operating System. It also runs multiple CP/M® 2.2 programs, Oasis™, MP/M, C, FORTRAN, MBASIC™, CBASIC, RATFOR, PL-1, Northstar compatible BAZIC™, Pascal and virtually thousands of existing applications programs. No other microcomputer offers you that kind of flexibility.

**Developing programs?** The Decision I's broad operating system base makes it a perfect software development system. And there's more.

**Multi-user, multi-tasking.** The Decision I can be configured for up to 15 users running 20 individual tasks. Memory management is similar to an IBM® 370's. And, a 7.2 MHz processor on the hard disk controller supercharges the system.

**The Micronix OS.** Micronix supports all system calls source-compatibly with the UNIX Operating System. Thus, UNIX programs will compile directly and UNIX documentation is almost totally applicable. Morrow's CP/M emulator has been configured to run under

Micronix, communicating directly with both UNIX and CP/M media.

**Performance.** In informal single-user benchmark tests against 68000-based machines running UNIX or UNIX-like operating systems, the Decision I won in every case. No 68000-based machine ran in multi-user mode, thus multi-user comparisons were impossible. But, these informal benchmarks would seem to prove that the combination of memory management and DMA I/O is as important as width of data path.

**Now, the price:** A single-user Decision I includes two 4MHz Z80A



UNIX is a trademark of Bell Laboratories  
CP/M and MP/M are registered trademarks  
of Digital Research, Inc.

Oasis is a trademark of Oasis Systems

IBM is a registered trademark of International Business Machines Corp.

MBASIC is a trademark, and Microsoft is a registered trademark of Microsoft Corporation

WordStar is a registered trademark of MicroPro, Inc.

BAZIC is a trademark of Micro Mike, Inc.



# ION 1

## almost everything.

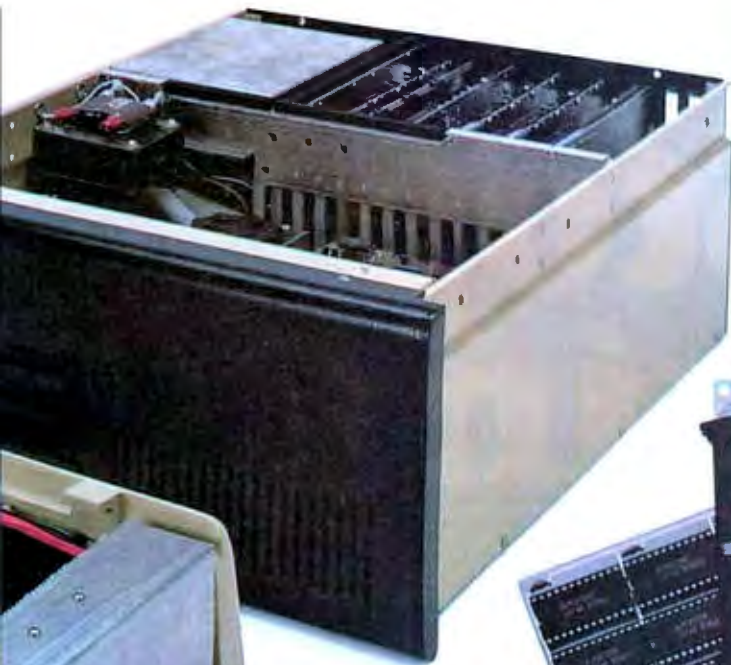

processors, 65K of static RAM, sophisticated memory management hardware, three serial and two parallel ports, a 14 slot S-100 motherboard, supervisor control in both hardware and software, cabinet and power supply. And of course, two 5 1/4" 48TPI floppy disk drives (800K), with Morrow DMA controller. Plus CP/M 2.2, industry standard Microsoft® BASIC 5.2 and WordStar®. Price: \$3,495. The same system with a 5 Megabyte Winchester, an additional 7.2 MHz processor, and a single 48TPI floppy costs \$5,295.

**Multiple user:** A three-user upgrade kit with three 65K static RAM boards and the Micronix Operating System is available for \$1,995, bringing the cost of a three-user hard disk based system to \$7,290. The Decision I is not simply an improved computer system. It's a breakthrough in computing power, operating system flexibility and price.

**Systems your way:** Morrow Designs also manufactures a full line of hard and floppy disk systems, add-in memory boards, I/O boards and disk controllers. That means you can configure your computer your way...through a single supplier.

**The Decision is yours.** Compare the Decision I, feature-for-feature with mini and microcomputers on the market today. Compare capabilities. Compare flexibility. Compare utility. Then, compare price. The Decision I is the only machine that runs almost everything. If you're developing software, or simply running it, that's a good thing to remember.

**LOOK TO MORROW FOR ANSWERS.**

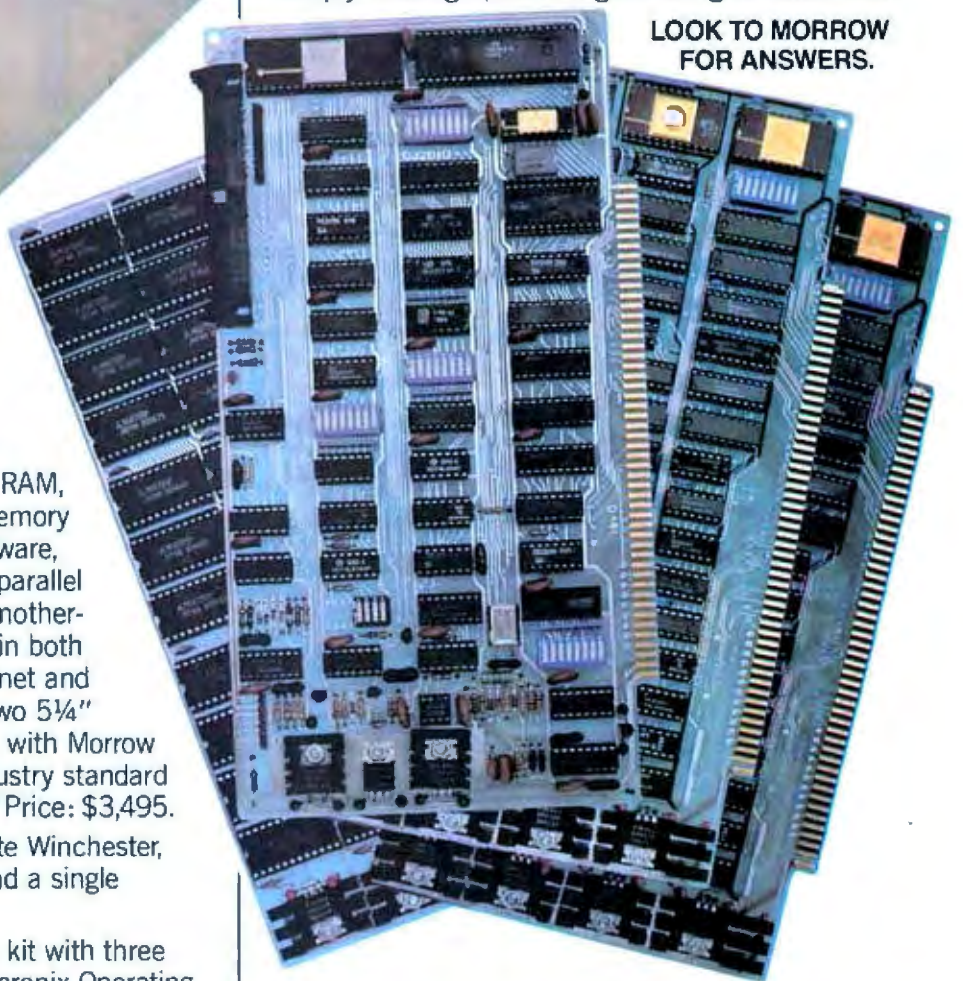

## MORROW DESIGNS

5221 Central Avenue, Richmond, CA 94804  
(415) 524-2101



Circle 328 on inquiry card.

# It's Time For Salespeople To Stop Talking



Because the more they talk, the less they listen. And *listening* is the key to sales productivity. When your salespeople *listen*, they can recommend product solutions that effectively satisfy your customer's needs and objectives.

**Trātec/McGraw-Hill**, a worldwide leader in training technology, has developed a way to significantly increase your sales productivity. It's called **Customer Oriented Selling (COS)**. In just three days, **COS** teaches your sales-

people the *customer's* perspective. It equips them with skills they can use to make the most sensible recommendation regarding the use of your products and services.

Many of the most successful sales organizations in the world are already using **COS**. If marketing your products and services requires a professional approach to selling, **COS** can work for you, too. To find out how, **Call Toll Free 800-421-4530**, or write to:

**In California Call  
(213) 204-3300**

**HARRY W. BLAKE**  
President/General Manager  
"I promise I'll listen"

Name/Title		
Company		
Address	State	Zip
Phone No.		

BT-982

**Trātec** 

Productivity through Training Technology

2999 Overland Avenue, Los Angeles, CA 90064

Circle 499 on Inquiry card.

Text continued from page 291:

able interrupt request), and the NMI (nonmaskable interrupt). When one of these occurs, the 6502 microprocessor vectors to the address at the top of ROM (read-only memory)—for IRQ, the two bytes starting at hexadecimal FFFE; for NMI, the two bytes starting at hexadecimal FFA—to obtain the addresses in memory that, in turn, hold the address of the user routine that handles the interrupt. Programs using interrupts ordinarily use IRQ because this eliminates the danger of interrupting a disk operation. Because we have no control over the software that might be running, we can't trust that any vectors we set in memory will stay, or even that the interrupt-enable status will not be changed. This means that the NMI must be used rather than the IRQ and that we must gain control over the interrupt-service routine before control is transferred to the soft vectors.

To accomplish the latter, we must have a way of substituting our own ROM for both the Apple's motherboard ROM and any language-card (or firmware-card) ROM that may be in use at the time. This is accomplished by using the INH (inhibit) line (available on the peripheral-card bus) to disable the motherboard ROM and by placing address hexadecimal C081 on the address bus momentarily, which (by convention) turns off the language card in slot 0.

### Swapping ROMs

After the NMI line goes low, the Apple's 6502 will execute one more instruction before servicing the interrupt. Since this instruction may be in ROM, we can't substitute our ROM for the Apple's until the interrupt is actually being serviced.

The adaptive-firmware board waits until the address hexadecimal FFA appears on the address bus, indicating that the first byte of the NMI vector is being fetched. Only at that time is the adaptive-firmware board activated and the competing ROM disabled. The RDY (ready) and DMA lines are used to halt the microprocessor while this is happening so that the first byte of the NMI vector is actual-

# 3270/BSC® & 3270/SNA/SDLC® PERSONALITY™ SERIES FOR



## IBM PERSONAL® COMPUTER

PERSONALITY™ SERIES offers fully IBM compatible multi-function adapters and software with exceptional flexibility and upgradeability.

PS-3270 PERSONALITY™ SERIES is the first fully IBM compatible 3270/BSC/SNA/SDLC emulator. Utilizing dedicated PS-GCA communication adapter, ABM's 3270/BSC emulator and CSI's ACCESS®/SNA emulator, it interfaces

with 3704/3705 communication controllers and emulates 3276 Control Unit Display Station supporting 3278 displays and 3287 printers.

### PERSONALITY™ SERIES HARDWARE

- PS-3276/BSC 3276 Control Unit Display Station and 3287 printer emulation **\$1295**
- PX-3276/BSC Add-on 3 3278 displays using downline async dumb terminals **\$495**
- PA-3276/SNA/SDLC 3278 display & 3287 printer (LU2/3) emulation upgrade **\$875**
- PS-3276/SNA/SDLC Control Unit Display Station and printer (LU2/LU3) emulation **\$1695**
- PB-3276/BSC 3278 display and 3287 printer upgrade **\$475**
- PC-3276/BSC/SNA/SDLC Combined emulation with interactive protocol switch **\$1995**
- PD-3276/BSC & PD-3276/SNA/SDLC Batch disc emulation upgrade **OCT 82**
- PS-GCA **\$995**  
General purpose communications adapter featuring Z80B processor, 64KB memory, 4 programmable serial ports (sync/async), 1 parallel printer port and 3 programmable timers.
- OMNI-BOARD™ **from \$205**  
Featuring up to five functions on one board, the OMNI-board provides the capabilities of an expansion chassis on a single board. Fully IBM compatible adapters provide a parallel printer port, up to two RS-232 asynchronous communication ports game adapter which is compatible with IBM software and connects to two Apple compatible joysticks and the clock/calendar option with rechargeable battery backup. No need to return to factory for upgrades - options are easy to install. Full documentation and software to read, set and automatically reset the system clock to the correct time and date automatically upon power-up included.  
Game & clock ..... \$205 Printer, game & clock ..... \$295  
Printer, clock & RS-232 ..... \$345 Printer, game, clock & RS-232 ..... \$395  
Printer, clock & 2xRS-232 ..... \$435 Printer, game, clock & 2xRS-232 ..... \$485
- EXPANDABLE MEMORY MEM-64K ..... \$279 MEM-128K ..... \$379  
MEM-192K ..... \$479 MEM-256K ..... \$579
- TELEPHONE RECEPTIONIST ADAPTER **\$995**  
The telephone receptionist adapter connects directly into a modular phone jack and provides a fully featured 300/1200 baud Bell 103/202 compatible modem with auto dial and auto answer. A voice synthesis unit and touch tone decoder provide interfaces for automatic telephone answering and remote data input. Audio and control outputs enable the IBM PC to function as a telephone answering machine.
- BSR-X10™ CONTROL MODULE **\$95**  
This integrated module plugs into the DIN cassette connector of the IBM Personal Computer and provides full remote control of 256 BSR appliance or switch modules and comes with sample software listing.
- \* COLOR TO MONOCHROME INTERFACE CABLE MODULE **\$95**  
Plugging conveniently between the IBM monochrome display and the RGB connector of the IBM color graphics adapter, this integrated module gives you the capability to use all the graphics and character line features of the IBM color graphics adapter with IBM monochrome display. \*(Actual photo above)
- APPLE™ JOYSTICK INTERFACE MODULE For 2 APPLE joysticks **\$29**
- PROTOTYPING BOARD With bracket and DB25 connector provision **\$49**
- PLUG-IN 5MB WINCHESTER DISK, ADAPTER & SOFTWARE **\$2195**

### PERSONALITY™ SERIES SOFTWARE

- DISKSAVER™ PROGRAM **\$49**  
This elegant utility program allows you to create backup copies of any software protected diskette. It offers the ultimate protection against accidental damage to your valuable software and comes with full documentation. The DiskSaver™ itself is not software protected.
- PASCAL GRAPHICS LIBRARY **\$95**  
This IBM PASCAL compatible library provides full access to the graphics of the IBM color graphics adapter. All graphics functions supported by the IBM BASIC are implemented as PASCAL procedure calls. Full documentation and software examples are included.
- PASCAL SUPPORT LIBRARY Provides full peripheral control for the IBM PC from PASCAL **\$49**
- DATAVIEW™ **\$195**  
This user friendly database generator allows you to custom design your database structure and define formats for data entry and display in an easy to follow interactive session.



**Automated Business Machines, Incorporated**  
29352 Avocet Lane, South Laguna, California 92677 USA  
(714) 643-0439

All ABM, Inc. products come complete with a one year warranty and IBM compatible documentation.

Enclose Check, Money Order or Visa/Mastercard Number and Exp. Date — Calif. residents add 6% sales tax.

Free shipping and handling on cash orders — Dealer Inquiries Welcome

ASK FOR ABM PERSONALITY™ PRODUCTS AT YOUR LOCAL COMPUTERLAND STORE.

# COMPUTER SPECIALTIES

SHOP FROM THE CONVENIENCE OF YOUR HOME OR OFFICE  
WITH THE BIGGEST SELECTION YOU CAN GET YOUR HANDS ON . . .

CALL OR WRITE FOR A FREE CATALOG AND SAVE!

IBM P/C • APPLE • ATARI • COMMODORE 64 • NEC •  
COLUMBIA DATA • VIC 20 • BASIS 108 • FRANKLIN ACE •  
COMMODORE/PET • PRINTERS

**ORDER TOLL-FREE! 1-800-854-2833**

## COLUMBIA

DATA PRODUCTS, INC.

### THE MULTI-PERSONAL COMPUTER

By Columbia can use Software  
and Hardware originally intended  
for the IBM® P/C . . .

- 8088 Processor
- 128K RAM
- Two RS-232 Serial Ports
- Centronics Parallel Port
- 8 Expansion Slots
- Dual Floppies with 1 Meg Storage

This exciting entrant to the IBM  
P/C compatibles is lower priced as  
compared to . . .

CALL FOR PRICE AND  
INFORMATION NOW  
1-800-854-2833

**NEC** PC-8000  
64 K



NEC PRINTER  
PC-8001 A  
NEC I/O Unit  
NEC add on Dual Drive  
NEC Green Screen

Call For  
Total System  
Price and . . .  
**SAVE!!!**

Call for Bill Jones and ask Bill for a free NEC catalog . . . and the  
lowest prices possible.

## Commodore

WE ARE A FULL SERVICE  
DEALER OF THE ENTIRE COM-  
MODORE PRODUCT LINE —  
INCLUDING THE LATEST IN  
CBM/PET COMPUTERS & SOFT-  
WARE — CALL US TOLL FREE  
FOR COMPLETE SELECTION  
AND LOW PRICES.

## VIC 20



### VIC HARDWARE

Vic Data Set . . . . .	58
Vic Disk Drive . . . . .	489
Vic Graphic Printer . . . . .	328
Vic 8K Memory Expander . . . . .	38
Vic 16K Memory Expander . . . . .	78
24K Memory Expander . . . . .	138
3 Slot Expansion (Mini-Mother) . . . . .	59
6 Slot Expansion (Card Board) . . . . .	117
RS 232 Card (Avail. Now) . . . . .	59
IEEE-488 Card (Avail. Now) . . . . .	69
Vic Super Expander . . . . .	48
Vicmon . . . . .	43
Joystick . . . . .	8
Paddles . . . . .	15
Light Pen by Syntek . . . . .	119
Vic Modem (Incl. Victerm) . . . . .	95
40/80 Column Card (Incl. Prom) . . . . .	179

### VIC SOFTWARE (ON CARTRIDGE)

Spiders of Mars . . . . .	36
Robot Blasters . . . . .	30
Meteor Run . . . . .	36
Satellites & Meteors . . . . .	36
Amok . . . . .	29
Alien Blitz . . . . .	29
Renaissance . . . . .	36
Alien . . . . .	19
Radar Rat Race . . . . .	23
Sargon II . . . . .	33
Trashman . . . . .	35
Blackhole . . . . .	35
Gorf . . . . .	23
Outworld . . . . .	29
Cloudburst . . . . .	29
Vic Avengers . . . . .	21
Super Slot . . . . .	21
Super Alien . . . . .	19
Super Lander . . . . .	21
Draw Poker . . . . .	20
Midnight Drive . . . . .	21
Adventure Land . . . . .	29
Pirate Cove . . . . .	29
Mission Impossible . . . . .	29
The Count . . . . .	29
Voodoo Castle . . . . .	29

### VIC SOFTWARE (ON TAPE)

Household Finance Pack . . . . .	26
Home Inventory . . . . .	12
Recreation/Education Pack I or II . . . . .	12
Personal Journal . . . . .	24
Ghostman . . . . .	19
Vi Calc . . . . .	11
Vi Check . . . . .	18
Vi Cat . . . . .	18
Bill Payer . . . . .	12
6 Packs by Vic . . . . .	44
Kosmic Kamakazi . . . . .	19
Sky Math . . . . .	11
Space Division . . . . .	11
Amok . . . . .	14
Alien Blitz . . . . .	18

**FREE CATALOG**

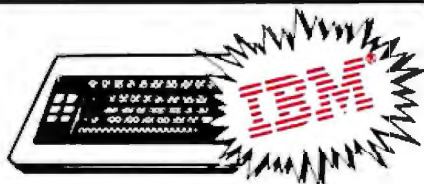

### ACCESSORIES APPARAT

Prom Blaster . . . . .	129
Clock Calendar . . . . .	109
Combo Card . . . . .	239
AST	
MC-064 SP (64K Combo Card) . . . . .	469
MC-128 SP (128K Combo Card) . . . . .	639
MC-192 SP (192K Combo Card) . . . . .	799
MC-256 SP (256K Combo Card) . . . . .	979
(All Above Include Asynch & Parallel Ports)	
64K Mem . . . . .	335
128K Mem . . . . .	499
192K Mem . . . . .	669
256K Mem . . . . .	799

### CHRISLIN INDUSTRIES

192K Mem Board . . . . .	629
256K Mem Board . . . . .	889
512K (with Serial RS232) . . . . .	995

### DAVONG

DSI-501 SMB Winchester Drive . . . . .	1595
DSI 64K Mem Card . . . . .	CALL
DSI 192K Mem Card . . . . .	CALL
DSI 256K Mem Card . . . . .	CALL

### MACROLINK

64K Memory Card . . . . .	369
128K Memory Card . . . . .	519
192K Memory Card . . . . .	659
256K Memory Card . . . . .	729

### QUADRAM

Quadboard 64K . . . . .	499
Quadboard 256K . . . . .	839
(Quadboard includes memory, clock/calendar, Parallel Printer I/O, Asynch RS232)	
Parallel Interface Card (B' Cable) . . . . .	129
Time Clock (Clock/Calendar W/Software) . . . . .	129

### SEATTLE COMPUTER

64K Ram + Board . . . . .	389
128K Ram + Board . . . . .	539
192K Ram + Board . . . . .	689
256K Ram + Board . . . . .	799
(All Ram + Boards Include RS-232 Serial Port)	

### BYAD

DSI Z-80 Board . . . . .	539
--------------------------	-----

### XEDEX

Baby Blue . . . . .	599
Run CP/M-80!	

### MONITORS & MISC.

Amdek Color II . . . . .	769
Electro Home RGB . . . . .	CALL
Joystick . . . . .	47
Modems . . . . .	CALL

### SOFTWARE

Everest Explorer by Acorn . . . . .	17
The Apple — IBM Connection by Alpha . . . . .	120
CP/M-86 by CompuView . . . . .	299
Vedit by CompuView . . . . .	123
The Programmer by Advanced . . . . .	419
Fastscreen by CompuView . . . . .	73
JANUS-86 by CompuView . . . . .	CALL
The Programmer . . . . .	369
Super Calc by Sorcim . . . . .	219
CP/M 86 by Digital Research . . . . .	279
The Organizer by Conceptual Instr . . . . .	209
C Basic by Digital Research . . . . .	259
Software from Digital Marketing . . . . .	CALL
Zork I, Zork II by Infocom . . . . .	39
Deadline by Infocom . . . . .	39
Easy Writer II by IUS . . . . .	258
Easy Speller by IUS . . . . .	128
Easy Filer by IUS . . . . .	298
Voys Writer by Lufre . . . . .	149
Basic-80 by Microsoft . . . . .	297
Basic Compiler by Microsoft . . . . .	335
Fortran-80 by Microsoft . . . . .	419
M.Sort by Microsoft . . . . .	159
Easy by Denver Software . . . . .	543
Home Accounting by Continental . . . . .	109
Visicalc (SInd) by Visicorp . . . . .	157
Visicalc (256K) by Visicorp . . . . .	194
Mathmagic by ISM . . . . .	69
Total Info Management by Innovative . . . . .	389
Logon by Ferox . . . . .	129

# FRANKLIN ACE 1000

CALL

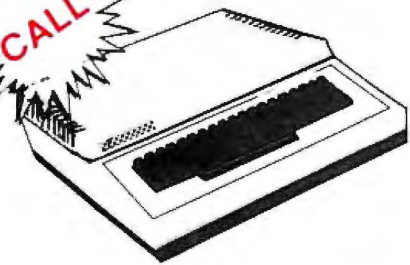

- Apple II software & hardware compatible
- 64K of RAM memory
- Upper and lower case
- Typewriter-style keyboard
- Twelve key numeric pad
- Alpha lock shift key
- VisiCalc friendly
- 50 watt power supply
- Built-in fan

## DISK DRIVES

Elite One by Rana	369
Elite Two by Rana	539
Elite Three by Rana	689
A-2 by Micro-Sci	379
A-40 by Micro-Sci	359
A-70 by Micro-Sci	499
A-3 by Micro-Sci	CALL
A-73 by Micro-Sci	CALL
3" Drives by Amdek	749
Super Drive by Fourth	299

**FREE\* SHIPPING**  
(with prepaid cash orders)



400 16K	268
800 16K	664

HARDWARE

410 Recorder	76
810 Disk Drive	444
830 Modem	158
850 Interface	159
Full-View 80 (80 Col Screen)	279
825 Printer	595
Joysticks (Pair)	18
Epson Cable	34
Intek 48K	199
32K by Microtek	109
Ram Crm	109
Ram Disk	429
THE ENTERTAINER	59
THE EDUCATOR	124
THE PROGRAMMER	56
THE COMMUNICATOR	334
THE BOOKKEEPER	194

PAC MAN \$29  
w/any purchase over \$100\*

Atari Word Processor	109
Microsoft Basic	68
Atari Basic Cartridge	49
Visicalc	189
Pilot (Home Pack)	59

We carry the complete line  
of Atari hardware and software —  
CALL FOR A FREE CATALOG

**PLUS 48K  
FOURTH DISK DRIVE  
WITH CONTROLLER**

**\$1758**

(Note: The hardware and software listed here is compatible with Apple, Basis 108, and the Franklin ACE-1000)

Vidterm by Videx	259
Z-80 Card by Microsoft	249
16K (2 year warranty)	59
32K by Saturn (incl Software)	189
AIO II by SSM	189
CCS Multifunction	159
32K by MPC	139
Numeric Keypad (23 Key)	119
Signalman Modem	79
Micro Modem II* by Hayes	278
Spooper Spooler	CALL
RGB Card	159
Enhancer II	124
Metacard by Metamorphic	895
Joystick by T.G	46
App-L-Cache 256K	995
Versacard by Promethius	169
Vision 80 by Vista	239
Infone by Novation	CALL
Microbuffer II (16K) by Practice	199
The Mill by Stellation	319
Expansion Chassis by Mountain	559
Synergy Card by Spies	169
Chronograph* by Hayes	189
Enhancer II by Videx	124
Lowercase for Apple	29
Sup R Mod (TV Interface)	35
Music System w/Software by Mtn	299
D-Cat Modem by Novation	169
A/D + D/A by Min Hardware	269
Supertalker SD200 by Min	154
The Grappler by Orange Micro	124
Versa Writer Digitizer	209
CCS 7710 A	129
Disk Emulator (294K)	799
Parallel Interface Card	69
Z-Card by ALS	189
ALF 9 voice	149
Pkasso by IS	CALL
Wizard-BPO	149
Synergizer Pack by ALS	578

**NEW**

Smart Modem* 1200 by Hayes	CALL
Appli-Card by Personal Cntr	CALL
Super Saver Fan	74
Ambler Monitor by USI	179
Videx Function Strip	59
8088 Card by ALF	295

# BASIS 108

The Alternative

- 6502 and Z80 Microprocessors
- 64K RAM, expandable to 128K
- RGB and Composite Video Output
- Selectable 80 or 40 column text display
- High Resolution Graphics: 6 colors, 280x192 or 280x160 with four lines of text
- 8 bit Parallel I/O • RS-232c Serial I/O
- Detached Keyboard: All standard keyboard functions, Upper/Lower case characters, Numeric keypad, Cursor block, and 15 Programmable special function keys
- Built-in mounting for two 5-1/4 inch floppy disk drives
- Six Apple compatible slots for plug-in peripherals • Game paddle I/O

## APPLE SOFTWARE BUSINESS

Business Packages by Continental	189 ea
Desktop Plan by Visicorp	184
Visi File	184
Visi Calc	184
Visidex	184
Visi Scheduling	236
Visi Trend/Visi Plot	199
Word Star by Micro Pro	199
Mail Merge by Micro Pro	148
Spell Star	176
Data Star	117
Calc Star	117
d Base II by Fox & Geller	494
Quick Screen for d Base II	127
Screen Writer II by On Line	95
Magic Window	69
Target Planner Calc by Comshare	36
Maths Magic by ISM	63
Graph Magic by ISM	62
Wall Streeter by Micro Lab	219
PFS: Report (New Improved) by S P Corp	69
PFS: Graph by Software Pub. Corp	89

## ENTERTAINMENT

U-Boat Command by Synergistic	24
Robot War by Muse	27
Firebug by Muse	18
Castle Wolfenstein by Muse	23
Conglomerates Collide by Rock Roy	27
Chopflifer	26
Pig Pen	23
Hungry Boy	23
Eliminator by Adven Int'l	23
Gorgon	35
Time Zone	79

CALL FOR COMPLETE CATALOG

# ORDER TOLL FREE! 1-800-854-2833

## PRINTERS in stock MAJOR BRANDS

CALL FOR BEST PRICE & FAST SERVICE

C. ITOH PROWRITER	
120 CPS F/T	459
NEC 8023A	489
TRANSTAR 140	
DAISY WHEEL	1350
40 CPS 132 COL	
IDS PRISM	
80 OR 132	CALL

- OKIDATA • QUME •
- ANADIX • DIABLO •

**Epson MX-100**  
**MX-80 F/T**  
**MX-80**  
with new graphics

# COMPUTER SPECIALTIES



**FREE CATALOGUE CALL**

TO ORDER Phone orders invited using Visa, MasterCard or bank wire transfers. Visa and MC service charge of 2% Mail orders may send charge card number (include expiration date) cashiers check, money order, or personal check (allow 10 business days for personal or company checks to clear) Please add 3% (\$5.00 minimum) for UPS shipping, handling, and insurance. APD and FPO include 5% (\$7.00 minimum) for postage. Calif residents add 6% sales tax. Please include phone number on all orders.

FOREIGN ORDERS include 1% handling — shipped air FREIGHT COLLECT only Credit cards not accepted on foreign orders All equipment is in factory cartons with manufacturer warranty. Opened products not returnable Restocking fee for returned merchandise. Equipment subject to price change and availability. Retail prices differ from mail order prices. WE SHIP THE SAME DAY ON MOST ORDERS! Min. purchase \$40. Deposit required on all COD's \*Excludes certain printers & monitors & foreign orders

Circle 116 on inquiry card.

MAIL TO: 1251 BROADWAY EL CAJON, CA. 92021 (714) 579-0330

ly obtained from our ROM on the firmware card. (Although it sounds complex, the process is implemented quite simply in hardware with a few integrated circuits.) A similar approach gives us control over the Reset vector.

Note that this use of the interrupt makes the card potentially transparent to all other programs using interrupts. As presently implemented, however, the card pulls the NMI line low and keeps it low until after the interrupt-service routine is finished. Another peripheral using the NMI in the same way would be incompatible. This problem could be solved by triggering the NMI with a pulse instead of a constant level.

### Reversing the Swap

When returning control to the main program after NMI service is completed, a program must reside in ROM that will remain accessible after the card is turned off so that the ROM swap can be reversed. This is easily done by making one page of the

ROM accessible at the addresses allotted to slot 7 (beginning at hexadecimal C700) by the Apple II's architecture.

### Soft Switches

Depending on the program running on the computer at the time, it may be necessary for the adaptive-firmware card to turn off the language card or to make use of the video display, which may involve switching from full-screen graphics to mixed text and graphics. Both of these operations involve the toggling of "soft switches" (programmable switches) in the Apple.

For the firmware card to remain transparent, it is important that everything be put back exactly as it was before the interrupt occurred. To do this, however, it is necessary to know the status of everything prior to interrupting the program. Unfortunately, many of the soft switches in the Apple cannot be read. They are actually hardware flip-flops set one way or the other by software's access-

ing particular addresses. For example, if the address hexadecimal C050 is accessed with a read or a write, the Apple goes into graphics mode. Conversely, accessing hexadecimal address C051 causes the Apple to go into text mode.

Similarly, the status of the expansion RAM card is determined by soft switches. In fact, pairs of address references may be used to establish the status of such a card. Thus, some method must be found for reading these unreadable switches.

Rather than try to read the hardware outputs of the flip-flops, the firmware card monitors the address bus continually and makes a note of the appearance of any address that falls into the category of soft switch. One way to do this would be to duplicate on the board the hardware representing those switches, but to do so in such a way that the duplicates could be read by the firmware card.

A better approach is to use the interrupt. Enough of each address on the bus is decoded to determine

## ◆◆◆ ANNOUNCING ◆◆◆

# What's Where in the APPLE...PLUS...the All New Guide to What's Where

William F. Luebbert's Revised Edition of the famous Apple Atlas

The original *What's Where in the APPLE?* provided more information on the apple's memory than was available anywhere else. Now the *Revised Edition*:

- Guides you — with a numerical Atlas and an alphabetical Gazetteer — to over 2,000 memory locations of PEEKs, POKEs and CALLs.
- Gives names and locations of various Monitor, DOS, Integer BASIC and Applesoft routines and tells you what they're used for.
- Enables you to move easily between BASIC and Machine Language.
- Guides you through the inner workings and hidden mechanisms of the Apple.

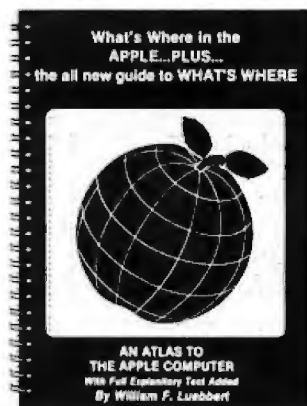

The Atlas and The All New Guide are available in one 256-page Wire-O-Bound book for only **\$24.95**

If you own the original *What's Where in the Apple?* you will want **THE GUIDE** to complement your edition. This 128-page, Wire-O-Bound version contains all new material to be used with the memory map and atlas for **\$9.95**  
Ask for it at your computer store

Use the Coupon to Order Direct from MICRO  
or  
Call Toll Free Today 1-800-345-8112  
(In PA 1-800-662-2444)

**All Apple users will find this book helpful in understanding their machine, and essential for mastering it.**

Please send me:

\_\_\_\_\_ What's Where in the APPLE...PLUS...  
the All New Guide to What's Where @ \$24.95

\_\_\_\_\_ THE GUIDE @ \$ 9.95

Add \$2.00 surface shipping for each copy,  
Massachusetts residents add 5% sales tax.

Total Enclosed \$ \_\_\_\_\_

Check  VISA  Master Card Acct # \_\_\_\_\_  
Expires \_\_\_\_\_

Name \_\_\_\_\_

Address \_\_\_\_\_

City \_\_\_\_\_ State \_\_\_\_\_ Zip \_\_\_\_\_

**MICRO INK, 34 Chelmsford St., P.O. Box 6502, Chelmsford, MA 01824**

B-9-82  
83-347

## PRODUCTS FOR THE APPLE II COMPUTER

# Give More Drive To Your



### MACRO-88 8088 PROCESSOR BOARD

With MS-DOS \$799 CDN  
\$699 US

- Apple can now run high-speed 16 bit software.
- True multiprocessing capability
- Interface to expansion memory allows up to 1 Mbyte of memory to be DIRECTLY addressable using 1 or more DISKULATORS. Contiguous memory is thus available for MS-DOS, UCSD PASCAL IV OR CP/M86.
- Supplied with MS-DOS.
- Socket on board for 8087.
- Macro assembler for use with MS-DOS available.

### DISKULATOR

128k - \$795 CDN  
\$599 US

- 64K/128K MEMORY BOARD FOR THE APPLE - the MACRO-MACROMEM.
- Disk emulation software for DOS 3.3, PASCAL AND CP/M - complete disk can be downloaded in 20 seconds!
- EXPANDABLE TO 384K (PIGGY-BACK board).
- Special circuitry for low current.
- Inter-faces to the MACRO-88 for contiguous memory for the 8088.
- Information on DISKULATOR can be accessed by the 6502 or 8088 in 4k banks.
- The most flexible and expandable Ram board for the Apple.
- VC-EXPAND and VC-EXPAND 80 for 64k and 128k boards for Visicalc expansion.

### MACROMEM-1

\$195 CDN  
\$139 US

- 16k memory board for the Apple II.
- DOS 3.3 MACRODISK SOFTWARE included.
- PASCAL and CP/M MACRODISK options.

### MACROMEM-2

\$299 CDN  
\$239 US

- 32k memory board for the Apple II.
- With software for moving DOS into one 16k bank. Second BASIC language can be loaded into the second bank.
- RAMEXPAND allows overlaying of programs and storing of large arrays in the memory board - effectively expanding the Apple memory for Applesoft.
- PSEUDODISK software included.
- VC EXPAND and VC-EXPAND 80 available.

### MACRODISK FOR 16K BOARDS

\$59 CDN  
\$49 US

- MACRODISK software turns one or more memory boards into a disk emulator.
- Free with all Macrotech memory boards.
- SAVE,BSAVE, RUN, BRUN, and other commands can be made to/from memory board as if it were a normal disk.
- Speed of transfer typically 2 to 10 times that of a real disk.
- Equivalent PASCAL and CP/M MACRODISK also available - Particularly valuable to PASCAL users as the 'second' disk drive in the system can be a MACRODISK - NO NEED TO BUY YOUR SECOND DRIVE!!
- Pascal Macrodisk automatically set up on boot.

**VC-EXPAND and VC-EXPAND 80 VISICALC EXPANSION** software by Saturn Systems available for 32k, 64k, and 128k memory boards - expansion of array size and use with 80 column boards.

### MACROPRINT Parallel Interface

\$175 CDN  
\$139 US

- Parallel INPUT AND OUTPUT inter face for Apple.
- Compatible with Apple software and hardware.
- Inverted acknowledge and strobe for printers requiring them.
- Low Res and Hi Res Graphics Dumps.
- An all-round best parallel board at best prices.
- Many many extra Commands - margin, width etc.
- Also the most attractive looking!

### MACROPEATER - AUTOREPEAT BOARD

\$35 CDN  
\$29 US

- Enables autorepeat on the Apple II.
- Press a key, hold down for a second and it will be repeated until released.
- Invaluable for VISICALC and word processing applications.
- Versions for old and new keyboards.
- Simple to install - no wiring!
- Compatible with other hardware or software including keyboard enhancer.

### DOSTILITIES

\$59 CDN  
\$49 US

- Password protection for DOS 3.3 disks.
- CATALOG MODS of all sorts - double catalogs, file-type I.D. mods etc.
- Error instruction modification.
- Printer-dump utility.
- Editor for EXEC TEXT FILES.
- Most valuable general utility for APPLE PROGRAMMERS.

### Dealer and distributor inquiries most welcome

- Apple II is a trademark of Apple Computer Inc.
- CP/M is a trademark of Digital Research Corporation.
- MS-DOS is a trademark of Microsoft Consumer Products Inc.
- U.C.S.D. is a trademark of Regents of the University of California.
- VC-EXPAND is a trademark of Saturn Systems LTD.

MACROTECH Computer Products LTD is also a distributor for:

Quality Software, Prometheus Products, Continental Software, Avante Garde Creations, Saturn Systems, Rocky Mountain Software, Xebec, A.L.S. etc. etc. and many more.

Payment may be made by VISA, certified check or money order.

MACROTECH Computer Products LTD  
4116 Grace Crescent  
North Vancouver, B.C. V7R4A1  
604-986-7633

MACROTECH Computer Products LTD. is also seeking other designers or manufacturers who are interested in MACROTECH Producing hardware or software products for the Canadian and international markets for dealer distribution (Considering the Canadian - U.S. dollar exchange rate this may be the only way for you to get your product to the market effectively in Canada).

# MACROTECH Computer Products Ltd.



# THIS MONTH'S TOP TEN

TITLE	MANUFACTURER	LIST	NOW
dBase II	Ashton-Tate	700.00	499.00
WordStar	MicroPro	495.00	299.00
WordStar w/MailMerge	MicroPro	645.00	385.00
Supercalc	Sorcim	295.00	210.00
Pascal MT +	D. Research	475.00	425.00
CalcStar	MicroPro	295.00	185.00
CB80	D. Research	500.00	420.00
FMS 80 I	Systems +	495.00	359.00
PL 1/80	D. Research	500.00	420.00
Select w/Superspell	Select Info Systems	595.00	395.00

## MOVING UP THE CHARTS.....

Spellguard	ISA	295.00	225.00
Supervyz	Epic	100.00	90.00
Spellbinder	Lexisoft	495.00	295.00
Condor II	Condor	595.00	450.00
Mathemagic	ISM	100.00	90.00
Condor III	Condor	995.00	750.00

OSBORNE OWNERS: dBase II Supervyz Quickscreen Spellguard Crosstalk, Mathemagic, and many others available for the Osborne I at our advertised prices!

## GREAT HARDWARE BUYS!

<b>NEW!</b>	C. ITOH 8500 PROWRITER Amazing 120 CPS printer w/Graphics logic seeking friction/fractor & more Parallel/8500 List \$795.00	\$515.00	
	Serial Parallel/8500 List \$845.00	\$650.00	
<b>NEW!</b>	C. ITOH F10 STARWRITER Daisy wheel Printer incredible 40 CPS printer with all the features of Diablo, NEC, and Qume at half the price! Parallel/Centronics interface unit. List \$1995.00	\$1475.00	
	Serial (RS-232) interface unit. List \$1995.00	\$1475.00	
	F10 Tractor Feed Option: List \$325	\$250.00	
	2K Buffer Option	CALL	
	Features Upgrade Option	CALL	
<b>NEW!</b>	SMITH-CORONA TP-1 Daisy-wheel printer Letter quality printing at an unbelievable price! 120 WPM parallel or serial interface (optional) List \$895.00	\$689.00	
	<b>PRINTER ACCESSORY PACKAGES:</b>		
	Apple II package: Complete package to interface with any of the above printers—includes cable and interface card	\$120.00	
	Osborne Package: Osborne cable to interface to any of the above printers	\$40.00	
	Other interface packages available for TRS-80 IBM Xenix Apple III etc.	CALL	
	<b>HAYES SMARTMODEM</b> List 279.00	\$227.00	
<b>NEW!</b>	<b>SIGNALMAN MARK I</b> direct connect modem Auto Answer W/RS 232 cable!!!	\$99.95	



## MORE SOFTWARE HITS.....

<b>ART INTELLIGENCE</b>	<b>FRIENDS SFTW</b>	<b>MICRO-AP</b>	<b>MICROSOFT</b>	<b>STD MICROSYS</b>
Denia 790.00	Access 81 485.00	Selector 785.00	BDI 81 275.00	Doc'n Fat 294.00
Magical 790.00	Access 81 485.00	Selector V 295.00	Macro 80 175.00	Mailman 1.1 85.00
<b>BUS PLAN 575</b>	<b>GRAHAM DORIAN</b>	Selector V 295.00	EDI 80 115.00	<b>STRUCT SYSTEMS</b>
Plan 80 241.00	Apr. Mgt. 115.00	Selector IV 295.00	MuVam 275.00	U.L. A Rec 115.00
<b>DIGITAL RESEARCH</b>	Reg. 85.00	Selector V 295.00	MuVam 275.00	A. Play Payto 85.00
PL 1/80 420.00	Play each 485.00	SBASIC 175.00	MSC 145.00	My GE ea. ch 85.00
DBasic 125.00	Gledg 85.00	<b>MICROPRO</b>	<b>SFTW DIM</b>	Analyst 175.00
CP M 135.00	OLEMS 85.00	DataSta 175.00	A I F 85.00	<b>SUPERSOFT</b>
MAL 85.00	Job ea ch 115.00	SuperSort 175.00	Modules 425.00	Dis Doctor 95.00
<b>EGDSOFT</b>	<b>KEY BITS</b>	SpellStar 175.00	MS.UO 785.00	Fortn 75.00
MicroStat 250.00	Wordsearch 175.00	<b>MICROSOFT</b>	<b>MIDW MICRO TEK</b>	SSS Fortran 10.00
<b>FIN PLAN ASSOC</b>	<b>MARK OF UNICORN</b>	Basic 80 75.00	ross Assem 250.00	tiny Pascal 80.00
Mini Mode 175.00	Music 148.00	Compiler 350.00	LBXX 250.00	Compile 75.00
<b>FOX &amp; GELLER</b>	Probe 148.00	Fortran 8 395.00	IBM 250.00	Statort 148.00
Quickscreen 140.00	Both 485.00			

This is just a sampling of the 117 titles available from DATASOURCE. For the great buying power that you get when ordering for APPLE II only, many of these titles are Apple II only titles.

## ORDER/TECHNICAL HOTLINE:

1-800-328-2260  
1-612-544-3615

**ORDERING INFORMATION** MAIL ORDERS customers, check us out!  
 Charge cards add \$3.00 shipping \$4.00 per software item. 2-1/2" disk software item. Min. order \$10.00.  
 Add \$2.00 for tax. Pricing and availability subject to change. Please call for order details.  
 All software is sold as indicated by the terms of the license. All software is sold as indicated by the terms of the license. All software is sold as indicated by the terms of the license.



## DataSource Systems

P.O. BOX 35007 MINNEAPOLIS, MN 55435 612-944-7907

whether the current address is a soft-switch reference. If it is, the lower byte of the address is latched and used to generate an interrupt. The interrupt-service routine then examines the latch to determine the identity of the soft switch and saves the information in memory on the firmware board. This approach allows a much greater number of soft switches to be monitored and at the same time suggests a unique way of generating the interrupts that relate to the main business of the card, as discussed below in Noticing Input.

## Split Addresses

Because the 6502 always executes one more instruction before responding to an interrupt, when two critical address references occur together it is possible that one of them would be missed. This could be solved in hardware by using a pipeline, but that complicates the hardware somewhat.

In order to keep the hardware simple and streamline the software service of the interrupts, the firmware card checks in software for double-address references when this seems possible. Admittedly, this is not a foolproof approach—routines could be written to fool the card—however, the probability of such exceptions seems quite small.

## Noticing Input

Given that the firmware card can respond reliably and transparently to requests for input, what is the best way to generate those requests? One method would be to have the card generate the interrupts whenever you activate a switch. Unfortunately, if the computer happens to be writing to disk when you activate the switch, data will be lost.

By including the address hexadecimal C000 (the keyboard data-input address) among the soft-switch addresses that produce interrupts, the computer itself will generate the interrupts whenever it checks for input from the keyboard. Then any check of the keyboard by the main program will turn on the adaptive-firmware board and let it check the special source of input, such as the user

DATASOURCE



# Build your own computer for \$79.95



## The Sinclair ZX81 personal computer kit

Imagine building your own computer for only \$79.95!

That's exactly what you can do with the ZX81 kit. It comes with all the parts you need and complete diagrams and instructions for putting it together. All you have to supply is soldering iron, solder, and a screwdriver. Plus, of course, a little bit of work.

But you get a lot more than several hours of kit-building fun. You also get a surprisingly powerful personal computer. The ZX81 hooks up to any TV for a 32-character by 24-line display (we provide the connecting cables). You can also use a standard cassette recorder to store your programs (again, we provide the cables).

Most important, you get a BASIC programming language that's powerful enough to challenge and interest the most experienced programmers. The ZX81 can handle multidimensional string and numerical arrays. It has full mathematical functions accurate to eight decimal places. Single-key entry for every command. Syntax error detection, debugging codes, and easy editing. Plus features that are ideal for creating games, such as 20 graphic symbols, continuous

display, and random number generator.

The ZX81 can be expanded too. You can increase the memory from 1K to 16K with our Memory Module for \$49.95. And you get a comprehensive manual that completely documents the capabilities of the ZX81, and teaches programming from the ground up.

In short, you get all the features that have made the Sinclair ZX81 the fastest selling personal computer in the world. And you get the satisfaction and fun of building it yourself.

A few years ago, this kind of computer power was simply unavailable to the individual. Even today, most personal computers are too expensive to buy for personal use.

But the ZX81 kit can be yours for only \$79.95. Take advantage of this unique offer today. To order, send the coupon along with a check or money order. Or for faster delivery, call our toll-free number and use your MasterCard or VISA.

**To order call toll free: 800-543-3000.**

Ask for operator #509. In Ohio call: 800-582-1364; in Canada call: 513-729-4300.

Ask for operator #509. Phones open 24 hours a day, 7 days a week. Have your

MasterCard or VISA ready.

These numbers are for orders only. If you just want information, please write: Sinclair Research Ltd., 2 Sinclair Plaza, Nashua, NH 03061.

AD CODE 09BYOK	MAIL TO: Sinclair Research Ltd., One Sinclair Plaza, Nashua, NH 03061.		
	PRICE*	QTY.	AMOUNT
ZX81 Kit	\$79.95		
16K Memory Module	\$49.95		
Shipping and Handling	\$4.95		\$4.95
*U.S. dollars	TOTAL		

Name		
Address		
City	State	Zip

Sinclair technology is also available in Timex/Sinclair computers under a license from Sinclair Research Ltd

# sinclair

switch. This has the net effect of inserting a few lines of a special translation program (from the firmware card) into the input loop used by the main program.

With this arrangement, the switch input may be monitored in an effectively continuous fashion, or at least as continuously as the keyboard is monitored by the main program. For an input-loop cycle less than a millisecond, the difference between this approach and the switch-generated approach is not likely to be perceived by most users. Most important, this approach eliminates the need to worry about interrupting the program during disk accesses.

### Separating Work from Play

You will sometimes want to use the input switches to simulate keyboard input (which causes the input algorithms to be triggered), while at other times you will need the switches for game playing. How can the firmware card know whether to treat the

switch activation as a keystroke (which would activate an input routine) or as a game-switch activation (which is just passed through to the game I/O address)?

The solution is to add the switch-read addresses, such as hexadecimal C061, to the set of addresses which generate interrupts and enable the card. The firmware card then checks to see what address reference it was that enabled it. If it was enabled by a call to the game switches, the user switch is treated as a game input. If the firmware card finds it is being polled for input from the keyboard, it will activate the appropriate input routine for the user. Thus the card automatically switches back and forth between keyboard and game-playing modes as required by the programs.

Even programs that do not call for any use of the keyboard, however, may address the keyboard location. For example, the BASIC interpreter checks the keyboard with nearly

every command to see if a control C has been pressed.

Because the BASIC interpreter can access the keyboard many times between accesses to the game paddles (once for most of the instructions it executes) the firmware card requires 256 consecutive accesses to the keyboard without an access to the game switch or paddle before it will leave the game-playing mode. If the computer program is checking for input from the keyboard, this occurs rapidly; if it is checking only for control C, the game-mode dropout will rarely happen.

If the above technique is used to defeat calls for control C, how would you ever be able to get out of a paddle-based program that was designed to use control C as its exit? The firmware card has an automatic game-mode dropout timer built in. If you don't hit the switch for a certain interval (determined by the stop-time option), the card automatically drops out of the game mode.

# DATAFACE D101: APPLE II™ IN ONE

## TURNS YOUR OLYMPIA ES101 OR REMINGTON 210 TYPEWRITER INTO A LETTER QUALITY PRINTER FOR THE APPLE II COMPUTER



The Dataface D101 Apple II™ Interface Card gives you a letter quality printer while allowing the full use of your office electronic typewriter. The D101 requires only one card, the cable is included. Installation—simply plug in! No jumpers to set and no soldering necessary.

**Suggested retail price \$349.50.**

Dealer Inquiries Invited.

\*Apple II is a trademark of Apple Computers, Inc.

**FOR OTHER COMPUTERS USE THE GRQ-11**  
Interfaces to the Olympia ES100, ES101, ES105 and Remington 210, 220 electronic typewriter.

# DATAFACE INC.

2372 A WALSH AVENUE, SANTA CLARA, CA 95050

TELEPHONE (408) 727-6704

# Fit Right in



Of course Percom diskette drives for the IBM Personal Computer fit right in. They fit right outside your Personal Computer, too. And they're fully compatible, providing the same full double-density storage capacity.

But just as important, Percom diskette drives also fit the same high standards set by IBM.

At Percom we've been making disk storage systems since 1977. We build quality, high-performance disk drive systems. From proven design through quality inspections that include 100% two-day operational tests. And Percom dealer support ensures competent after-sale service.

So expect more from Percom. You won't be disappointed.

Percom disk drives for the IBM Personal Computer are available in 40-track single- and dual-head models, and 80-track single-head models. Call or visit your independent IBM Personal Computer dealer — and fit right in with Percom. For the names of dealers carrying Percom products for your Personal Computer call toll-free 1-800-527-1222.

PRICES AND SPECIFICATIONS SUBJECT TO CHANGE WITHOUT NOTICE



PERCOM DATA COMPANY, INC.

11220 PAGEMILL RD • DALLAS TX 75243 • (214) 340 7081

IBM and IBM PERSONAL COMPUTER are trademarks of International Business Machines Inc  
PERCOM is a trademark of Percom Data Company Inc



Minimum system requirements are an IBM System Unit with 16 Kbytes of RAM and 5 1/4" Diskette Drive Adapter Drive models supported depend on DOS used. An optional cable available from Percom is required for external (add-on) drives.

Yes... I'd like to know more about Percom diskette drives for my IBM Personal Computer. Rush me free literature.  
Send to: PERCOM DATA COMPANY, Inc., Dept. 2-B01  
11220 Pagemill Road, Dallas, Texas 75243

name \_\_\_\_\_

street \_\_\_\_\_

city \_\_\_\_\_ state \_\_\_\_\_

zip \_\_\_\_\_ phone number \_\_\_\_\_

I intend to add a hard-disk system to my computer  yes  no.  
MAIL TODAY!

# BRAINS-MAINFRAMES

## SUPERBRAINS



**SUPERBRAIN QD 64K**

List \$2995. . . . . only \$2449



Z-89 48K  
List \$2895 . . . . . only \$2099  
Z-90 64K DD 3195  
ONLY \$2489

## COMPUSTARS

Available to Dealers

### NORTH STAR

Minicomputer  
Performance

Green Phosphor  
Options:  
Graphics + CP/M

List . . . . . \$3,999  
Only . . . . . \$2,989

### ADVANTAGE



Monitor Green Phosphor \$114

TERMINALS Z-19 . . . . . \$638  
INTERTUBE III Super Smart . . . . . \$710

## EPSON

MX-80 FT. . . . . \$598  
MX-80 . . . . . \$474  
MX-100 . . . . . \$749

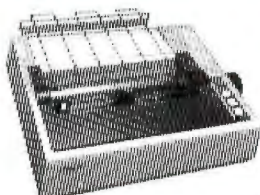

ANADEX 9501 . . . . . \$1290  
NEC Letter Qual Friction & Tractor . . . . . call  
ZENITH printer Z-25 list 1595 only . . . . . \$1256  
C. Itoh F10 Letter quality . . . . . \$1449



ATARI 400 . . . . . List \$399. . . . . only \$340  
800 . . . . . List \$899. . . . . only \$675

Wonderful Games—Education for your family

Main Frames-S-100 . . . . . \$200 up  
Advanced Micro Digital Superquad Single Board Computer  
with Z80 64K and FDC . . . . . \$749  
Dual 68000 CPU S100-Super Fast—Save . . . . . CALL

AMERICAN SQUARE COMPUTERS is organizing a World Wide Association of Computer Dealers. Open a Store or Start Work Out of Your Home! We Charge NO FRANCHISE FEE! (Our Competitors charge a FRANCHISE FEE of from \$15,000.00 to \$45,000.00.) Be a Winner! Let US help YOU get started MAKING MONEY by HELPING PEOPLE to put COMPUTERS to WORK. Write or Phone today.

TELEVIDEO TERMINALS . . . 910 \$518, . . . 925 \$718

### GODBOUT COMPUPRO

Super Sixteen 8085/8088 is the fastest combo 8/16 CPU. LIST . . . . . \$3904 . . . . . Special \$2873

### SEATTLE'S

16 bit COMPUTER is here! 8 MHz 8086 CPU the fastest S-100 computer! 128K Static RAM, DD Disk Controller, 22-slot Main Frame, 86-DOS, #2 128K  
LIST . . . . . \$4185 . . . . . ONLY \$3349  
#1 As above but 64K LIST . . . \$3190 . . . ONLY 2649

### CALIFORNIA COMPUTER 2210A

LIST \$1995 . . . . . ONLY \$1722  
Z80, 64K, I/O, Disk controller + CP/M.  
Model 302 is the larger system: 2.4 Mb 8" Z80, 64K, and optional OASIS, CP/M, or MP/M operating system.  
LIST . . . . . \$5295 . . . . . ONLY \$4674

### SYSTEMS GROUP SYSTEM 2800

Runs CP/M or OASIS. Supports single user & multi-user & multi task. Up to 5 megabytes with 8" drives. Optional 10-megabyte hard disk. Optional tape back up #2812 \$5035 . . . . . ONLY \$3775

### TARBELL'S

Empire I&II have two 8" disk drives. The I is single sided, the II is double sided.

### FREE Business Software

Empire I LIST \$4888 . . . . . Only . . . . . \$3666

We sell The Finest Hardware

We sell The Finest Software

# AMERICAN



# COMPUTERS

919-889-4577

4167 Kivett Dr.

Jamestown, NC 27282

919-883-1105

# LOWEST PRICE - BEST QUALITY

## NORTH STAR Horizon 2



2-5 1/4" Disk Drives  
64K Double Density  
Factory assem. & tested  
Factory guaranteed

A few left  
Low Price only  
**\$2499**

**Powerful North Star BASIC Free  
Superb for Business & Science**

HORIZON STANDARD IS NOW HRZ-2-64K QUAD

Factory Assembled & Tested	List	Only
Horizon-2-64K-Quad .....	\$3599	\$2689
Horizon-1-64K-QHD 5 .....	\$5999	\$4559
Horizon RAM ASM. .... 32K = \$424 64K = \$594		
Big Sale on Multi-User Time-Sharing		call
English to Basic Translator .....		\$99
North Star Hard Disk 18 Mb. ....	\$5375	\$4568
North Star Time Sharing Multi User		call
Zbasic 2 to 5 times faster! .....	\$350	call
Secretary Word Processor .....		\$99
Wordstar Word Processor .....		\$296
Floating Point Board .....	\$399	\$339
Oasis Multi-User Software .....	SAVE	call
CP/M for N* Extra features .....		\$230
Micro Mike Software .....	SAVE	call
Ecosoft Accounting MICROSTAT		\$265
Pascal-80 .....	\$600	\$515
Extra Precision Basic .....		\$50
Northwood .....	\$199	\$179
Mailmanager .....	\$299	\$224
Infomanager .....	\$399	\$349
General Ledger .....	\$499	\$429
Accounts Receivable .....	\$499	\$429
Accounts Payable .....	\$499	\$429
Inventory .....	\$499	\$429
Order Entry .....	\$499	\$429
PROPAC .....	\$1499	\$1274
DOS + Basic 5.2 .....		27

## DECISION I



"The IBM-360 on the Z-80 & S-100 BUS!"

Sixteen Programs running simultaneously! Free CPM, Microsoft BASIC and WORDSTAR with Complete system!

	LIST	ONLY
DECISION 1 + 65K Static + 8" Disks .....	\$4375	3377
DECISION 1 + 65K Static + 2 - " Disks .....	4195	3149
DECISION 1 + 65K Static + 5" Disk + 5MB Hard Disk .....	5990	4784
DECISION 1 3 user 195K Static + 5" Disk + 5Mb Hard Disk + MICRONX	8035	6428
DECISION 1—Z-80 + 1/0 = Power .....	1725	1294

## MORROW 8" Disk

Discus 2D + CP/M 600K only \$834  
Discus 2 + 2 + CP/M 1.2 MEGA B \$1074  
Add Drives 2D = \$599 2 + 2 = \$795  
Discus 2D-dual + CP/M Only \$1384  
Free Microsoft BASIC from MORROW with Discus system or hard disk



M-26 MORROW Hard Disk  
26,000,000 Bytes!!  
List \$4495 .....

Only \$3394  
Free CPM + BASIC  
M-20 List \$4795 .. Only \$3835  
M-10 List \$3695 .. Only \$2955  
M-5 List \$2495 .. Only \$1994

## InterSystems

Z-80A CPU 4 MHz  
64K Dynamic RAM  
Front Panel

VI/0-1 - with interrupts  
FDCII Disk Controller  
20 slot motherboard

List \$3795 .....

Only \$2839

Without front panel as above only \$2716  
Front Paneless Recommended for Business

## Save on Memory and Programs

Systems Memory 64K A&T ..... \$459  
Systems Memory 64K Bank ..... \$555  
Microangelo ..... \$985

Corvus Hard Disk ..... SAVE  
SSM Video BRD VB3 kit ..... \$361  
Spectrum Color ASM ..... \$326

Cat Novation Modem ..... \$169  
Memory Merchant 16K ..... \$159

Which Computers are Best?—FREE.  
Insured Shipping at Low Rates. Call  
For Latest Prices, Details. We Beat  
Advertised Prices.

Factory Guarantees

Expert Advice

# AMERICAN



# COMPUTERS

919-889-4577

4167 Kivett Dr.

Jamestown N.C. 27282

919-883-1105

## Emulating the Keyboard

For the entire firmware card to work effectively, it is necessary that it be able to make the computer think that its output is actually coming from the keyboard itself. The most straightforward approach, which is characteristic of most other emulator cards, is to disconnect the keyboard from the main computer and plug the emulator card directly into the keyboard plug on the Apple II motherboard. In order to allow the keyboard to work under this scheme, the keyboard would be plugged into the firmware card. However, this approach requires that the bottom of the computer be removed to provide access to the connectors. Installing the card in this manner is a rather difficult and time-consuming procedure.

An alternate approach is to tap into the I/O decoding by removing one of the decoder ICs and substituting a jumper to the firmware card. The function of the missing device can then be performed selectively by the firmware card. When appropriate, a

signal that would ordinarily enable some element of the I/O section of the Apple may be diverted to active memory on the firmware card. In particular, we can arrange to have location hexadecimal C000 decode an address in memory on the firmware card; that is, when the computer tries to read the keyboard, it in fact reads whatever is placed into that location on the firmware card.

This offers a few advantages. First, this arrangement makes installation of the firmware card much easier because the bottom of the computer need not be removed. Second, if it is designed so that the rearrangement of the decoding occurs only when the card is turned off, the keyboard latch and strobe arrangement will be left intact and will function in the normal fashion when the card is turned on. (This allows the card to directly read the keyboard and pass any keyboard input through as well.) Third, this technique allows the firmware card to intercept references to the game-paddle ports, thus allowing the card

to do game-paddle emulation.

## Paddle Emulation

If we want to allow the user control over the paddle input, some mechanism must be provided to simulate the game paddle. The most straightforward method would be to install a variable resistor in the game slot that could be controlled by the firmware card, but this approach is fairly hardware-intensive. By carrying the substitution of memory for I/O one step further, however, it is possible to gain software control of the values obtained when the game paddles are read.

The Apple's 100-k $\Omega$  potentiometer inputs are read by means of timers. In normal operation, the position of the game paddle is read in the following fashion: the X register is loaded with the paddle number; the Y register is used as a counter. The process begins by setting register Y to 0. The NE555 timer is then triggered by a reference to address hexadecimal C070. The processor then goes into a loop, incrementing Y and checking address hexadecimal C063 + X (where X is the paddle number). When the timer runs out, it clears the most significant bit of hexadecimal address C063 + X. When this is detected by the loop, the program exits the loop and uses the value of the Y register as the paddle value.

With the firmware card, there are two ways to program the game-paddle value that is read by a program running on the computer. The first method (used by paddle modes 8 through 15) begins by disabling the decoding so that each time the computer addresses hexadecimal C063 + X it gets an address in the memory on the firmware card instead of checking the actual hardware switch. The firmware card simply increments one of its own counters and then passes control back to the paddle timing loop.

After the firmware card has been accessed the desired number of times (i.e., the value in the Y register is equal to the desired value), the most significant bit in memory location hexadecimal C063 + X (in the firmware-card memory) is set to 0,

## PUT YOUR APPLE TO SLEEP



Plug HIBERNATOR into your APPLE power socket - Plug RealClock into APPLE slot - Set ALARMCLOCK Interrupt Mode Power OFF - your APPLE will WAKE UP (after sleeping for milliseconds to months) - Boot up - Execute your program and if you wish, go back to sleep again - etc. Your APPLE consumes NO power while asleep - NO over-heating

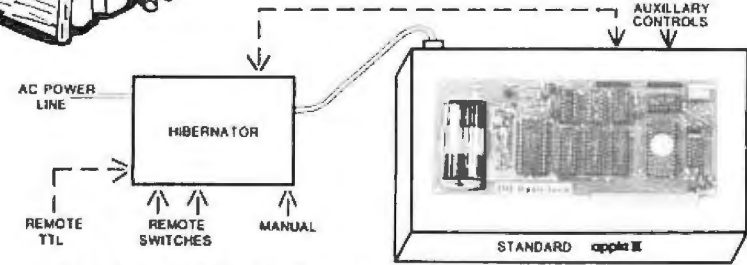

**HIBERNATOR + IMI REALCLOCK**

- AUXILIARY AC POWER OUTLETS
- LED STATUS INDICATORS
- CONTROL FROM: REALCLOCK, TTL/SWITCH INPUTS, MANUAL/SOFTWARE
- OPTIONAL AC LINE FILTER
- FOUR INTERRUPT MODES
- PERIODS FROM MILLISECOND TO MONTHS
- APPLESOFT/INTEGER COMPATIBLE
- AUXILIARY CONTROLS CONNECTOR
- MACHINE LANGUAGE DOCUMENTATION
- REALTIME RESOLUTION 1 MILLISECOND

Hibernator \$79. RealClock \$190 Purchased together \$259 (Add \$12 for AC Line Filter)  
Hibernator & RealClock also available in kit form  
Price includes Demo disk with menu driven software Applications Assistance & Instruction Manual  
Instruction Manual available separately \$10 (deductible from RealClock purchase)  
WARRANTY ONE YEAR on LABOR and PARTS

TO ORDER Please send cashier's check money order or personal check (allow 10 business days to clear)  
Visa and MasterCard add 3% Shipping & insurance in U.S. add \$5 CA residents add 6% sales tax  
SAVE \$5 by enclosing this ad with your order or quote ref #89

**INNOVATIVE MEASUREMENTS INC. P.O. Box 3879, San Clemente, CA 92672 Tel. (714) 493-2174**

## A one-day seminar on Writing User Manuals That Sell

You know better user manuals sell more software, but how do you make better user manuals? How do you identify just the right details to motivate prospective users to buy? How do you organize these details into a sequence that makes sense to first-time users while it provides ongoing reference to veterans? How do you format and package a manual so it's attractive enough

to get attention yet clear enough to be readily understood? And, how do you do all this at a pace that keeps up with your product release schedule? This seminar has the answers.

If you're an individual software author or a software company in the business of publishing or selling software, or if you'd like to be, you can benefit from this seminar. Unlike seminars that concentrate on the academic do's and don'ts of technical writing and formatting, this seminar gets down to the business value of the user manual as a marketing and sales tool that helps you get more users and keep them.

Developed and conducted by software marketing professionals with over 50 years of collective experience in writing software manuals for the commercial market, this seminar is loaded with facts and ideas on these subjects:

### Manual Design

How to make content, organization, page layout, and document format work to your sales advantage without spending a fortune.

### Training vs. Reference. Can one manual do both?

How to implement the techniques of tutorial writing into a well organized reference format that provides easy access for later questions.

### Packaging That Controls Point of Sale

How to make your manuals work for you at the point of sale to help the dealer present your software in its most competitive light—both on the shelf and on the demonstration machine.

### Automated Manual Writing

How to let the software document itself wherever possible, and how to use word processing systems effectively to obtain maximum value from automated publishing tools.

### Seminar Manual

All attendants will receive a detailed "How To" manual on writing and producing user manuals for commercial use. Many past attendants have praised the manual and other handout materials as being worth the price of attendance by themselves.

### Schedule:

October 5	New York	November 2	Denver
October 7	Atlanta	November 4	Seattle
October 19	San Francisco	November 16	Dallas
October 21	Los Angeles	November 18	Chicago

### Only \$145 With Our Guarantee

Price includes lunch and materials. We offer a 10% discount for companies sending more than one person.

### Get Details Today!

Space is limited so make your reservation now. Use the coupon to enroll now, or to get enrollment details, simply call Michele Keplinger (303) 471-9875.



## PromptDoc®

833 West Colorado Avenue Colorado Springs, CO 80905

See our software ad in this issue.

### How To Enroll

Please reserve \_\_\_\_\_ seats in (city) \_\_\_\_\_  
\_\_\_\_\_ seminar on (date) \_\_\_\_\_

Please check appropriate items:

My check is enclosed for \$ \_\_\_\_\_

You may charge \$ \_\_\_\_\_ to my Master Card  VISA \_\_\_\_\_

account number \_\_\_\_\_ which expires on \_\_\_\_ 198\_\_

Signature \_\_\_\_\_

Names and Titles of Registrants: \_\_\_\_\_

Company Name \_\_\_\_\_

Mailing Address & Telephone \_\_\_\_\_

### Tuition Refund Guarantee

If you aren't satisfied this seminar is everything we say it is, just tell us in writing why you're dissatisfied, return the seminar manual, and we'll send you a full tuition refund.

### Ask About Our Other Services

- Send information on other seminar offerings
- Send information on in-house seminars
- Send information on the Prompt Doc® structured documentation service
- Send information on the Prompt Doc® Manual Maker software package

and control is again returned to the paddle timing loop. The loop detects the most significant bit (thinking that it is seeing the timer flag) and exits from its loop, carrying with it the value for Y that the firmware card wants it to have. This approach has the advantage that it will work no matter who writes the timing loop and what registers are used for counters. It has the disadvantage, however, that it can actually slow the program down by interjecting additional instructions into the otherwise very tight timing loop.

The second method (used by paddle modes 1 through 7) takes advantage of the fact that most of the paddle timing loops examined (both in software written by Apple Computer Inc. and in other packages) seem to use either the X or Y register as a counter. Because this is the most convenient method for doing paddle timing and allows the highest resolution, it is reasonable to assume that one of the two registers will be used in most or all software paddle timing

loops.

Based on this assumption, the firmware card immediately checks the values of the X and Y registers when address hexadecimal C070 is first accessed. It then returns control to the loop and allows it to complete one cycle. When the loop accesses address hexadecimal C063+X, the firmware card is again activated. It then checks registers X and Y to see which of the two registers has changed. The program assumes that this is a counter and then loads the desired paddle value into that register, sets the most significant bit in address hexadecimal C063+X (in the memory on the firmware card), and returns control the Apple paddle timing loop.

The loop immediately discovers that the most significant bit is set and breaks with the value in the register as the "paddle timer value." In this manner, the software routine can very quickly inject any paddle value into any program. If software is discovered that uses other registers, a more complicated search routine can

be used to find the proper register to "stuff" (store) with the desired paddle timer value. The end result is that individuals using only a single switch or other alternative input techniques can control paddle movement, through the firmware card, and other software applications.

### Where Is the Top of Memory?

A drawback of the I/O RAM approach is that the address hexadecimal C000 becomes an element of RAM, which could fool an operating system trying to find the top of memory. This does not happen with DOS, but it does happen with Integer BASIC in ROM, if that language is started with control B. The solution in this case is to specify HIMEM. The problem doesn't arise, however, if the disk system is used.

### Cassettes and Interrupts

The cassette-input address hexa-

COMPUTERS  
**ATARI 800™**  
**COMPUTER SYSTEM**



800w 16K \$699.00  
\*800 Computer w/48K  
BEST BUY \$ **790.00**

**ATARI PERIPHERALS:**

Printer 825 - 650.00	Asteroids
Disk Dr 810 - 485.00	Missile Com -> 32.50
Record 410 - 82.00	Sup Bk Out
Paddle (pr) 16.96	Assem Ethn - 49.00
Joystick (pr)	Star Raiders - 45.00
3 1/4 RAM - 179.95	Basketball - 28.00
Basic Cart - 49.00	Chess - 32.00
Pac-Man -> \$36.95	

\*SPECIALS\*

3inch Mini FAN -> \$8.95  
2111 -> \$2.45  
8155 -> \$11.50  
ER2501 -> \$4.95  
AY5 1013A -> \$2.55  
8202 -> \$29.95  
6522 -> \$5.25  
8255 -> \$5.95  
8748-8 -> \$31.00  
MC6800 -> \$7.75  
MC6802 -> \$14.95  
MC6850 -> \$4.50  
MC6821 -> \$4.95  
6331 -> \$1.25

.....

4116-2 -> 8 / 1200  
2716(5v) -> 3.75ea.  
2732(5v) -> 8.75ea.  
2532(5v) -> 8.75ea.  
Z80A CPU - 5.25ea.  
1982 I.C.  
(2vol.) Master  
\$59.95

**CONCORD COMPUTER PRODUCTS**

1871 SO STATE COLLEGE  
ANAHEIM, CALIF. 92806  
(714) 937-0637

send \$1.00 for catalog

NO COO

10 MIN ORDER CA RES ADD 6

**FREIGHT MONITORS**

ZENITH # ZVM-121  
12in 15MHz./GREEN Phos  
\$113.00

J.C.S.# KG-12  
12in 19MHz./GREEN Phos  
Non-Glare Screen \$134.50

BMC# BM-12A  
12in 15MHz./GREEN Phos  
\$89.50

AMDEK# CM-13 (COLOR I)  
13in./COLOR!! \$375.00

**COMPONENTS**

74LS00	24	74LS83	70	MISC	
74LS04	24	74LS90	38	8134	1.30
74LS10	24	74LS95	65	8178	1.25
74LS16	24	74LS107	38	8034	2.75
74LS20	24	74LS109	40	8090A	3.75
74LS24	24	74LS112	40	8255	4.50
74LS26	24	74LS114	40	MC1330	1.65
74LS28	24	74LS117	40	MC1350	1.15
74LS30	24	74LS123	40	MC1358	1.50
74LS32	24	74LS125	40	MC1458	5.50
74LS37	20	74LS138	40	LM350	1.10
74LS39	24	74LS14	45	LM385	1.40
74LS42	24	74LS153	90	LM505	9.95
74LS48	24	74LS154	90	LM741	1.40
74LS51	24	74LS155	90	LM1310	2.90
74LS54	24	74LS157	70	LM1800	2.95
74LS57	24	74LS159	65	1488	9.95
74LS60	24	74LS160	70	1489	9.95
74LS64	24	74LS161	70	8212	1.95
74LS67	24	74LS162	70	8276	1.80
74LS72	24	74LS163	65	1032A	9.95
74LS74	24	74LS164	85		

MS SERIES

74500	35	74506	1.10
74502	38	74512	1.45
74503	38	74513	1.15
74504	45	74518	9.95
74505	85	74540	1.25
74506	80	74519	1.25
74510	55	74514	9.95
74515	55	74515	9.95
74516	55	74516	9.95
74517	55	74517	9.95
74518	55	74518	9.95
74519	55	74519	9.95
74520	55	74520	9.95
74521	55	74521	9.95
74522	55	74522	9.95
74523	55	74523	9.95
74524	55	74524	9.95
74525	55	74525	9.95
74526	55	74526	9.95
74527	55	74527	9.95
74528	55	74528	9.95
74529	55	74529	9.95
74530	55	74530	9.95
74531	55	74531	9.95
74532	55	74532	9.95
74533	55	74533	9.95
74534	55	74534	9.95
74535	55	74535	9.95
74536	55	74536	9.95
74537	55	74537	9.95
74538	55	74538	9.95
74539	55	74539	9.95
74540	55	74540	9.95

EPROMS

1707	4.75	813 89ea
3706	4.75	813 89ea
3708	4.75	813 89ea
3710	4.75	813 89ea
3712	4.75	813 89ea
3714	4.75	813 89ea
3716	4.75	813 89ea
3718	4.75	813 89ea
3720	4.75	813 89ea
3722	4.75	813 89ea
3724	4.75	813 89ea
3726	4.75	813 89ea
3728	4.75	813 89ea
3730	4.75	813 89ea
3732	4.75	813 89ea
3734	4.75	813 89ea
3736	4.75	813 89ea
3738	4.75	813 89ea
3740	4.75	813 89ea
3742	4.75	813 89ea
3744	4.75	813 89ea
3746	4.75	813 89ea
3748	4.75	813 89ea
3750	4.75	813 89ea
3752	4.75	813 89ea
3754	4.75	813 89ea
3756	4.75	813 89ea
3758	4.75	813 89ea
3760	4.75	813 89ea
3762	4.75	813 89ea
3764	4.75	813 89ea
3766	4.75	813 89ea
3768	4.75	813 89ea
3770	4.75	813 89ea
3772	4.75	813 89ea
3774	4.75	813 89ea
3776	4.75	813 89ea
3778	4.75	813 89ea
3780	4.75	813 89ea
3782	4.75	813 89ea
3784	4.75	813 89ea
3786	4.75	813 89ea
3788	4.75	813 89ea
3790	4.75	813 89ea
3792	4.75	813 89ea
3794	4.75	813 89ea
3796	4.75	813 89ea
3798	4.75	813 89ea
3800	4.75	813 89ea
3802	4.75	813 89ea
3804	4.75	813 89ea
3806	4.75	813 89ea
3808	4.75	813 89ea
3810	4.75	813 89ea
3812	4.75	813 89ea
3814	4.75	813 89ea
3816	4.75	813 89ea
3818	4.75	813 89ea
3820	4.75	813 89ea
3822	4.75	813 89ea
3824	4.75	813 89ea
3826	4.75	813 89ea
3828	4.75	813 89ea
3830	4.75	813 89ea
3832	4.75	813 89ea
3834	4.75	813 89ea
3836	4.75	813 89ea
3838	4.75	813 89ea
3840	4.75	813 89ea
3842	4.75	813 89ea
3844	4.75	813 89ea
3846	4.75	813 89ea
3848	4.75	813 89ea
3850	4.75	813 89ea
3852	4.75	813 89ea
3854	4.75	813 89ea
3856	4.75	813 89ea
3858	4.75	813 89ea
3860	4.75	813 89ea
3862	4.75	813 89ea
3864	4.75	813 89ea
3866	4.75	813 89ea
3868	4.75	813 89ea
3870	4.75	813 89ea
3872	4.75	813 89ea
3874	4.75	813 89ea
3876	4.75	813 89ea
3878	4.75	813 89ea
3880	4.75	813 89ea
3882	4.75	813 89ea
3884	4.75	813 89ea
3886	4.75	813 89ea
3888	4.75	813 89ea
3890	4.75	813 89ea
3892	4.75	813 89ea
3894	4.75	813 89ea
3896	4.75	813 89ea
3898	4.75	813 89ea
3900	4.75	813 89ea
3902	4.75	813 89ea
3904	4.75	813 89ea
3906	4.75	813 89ea
3908	4.75	813 89ea
3910	4.75	813 89ea
3912	4.75	813 89ea
3914	4.75	813 89ea
3916	4.75	813 89ea
3918	4.75	813 89ea
3920	4.75	813 89ea
3922	4.75	813 89ea
3924	4.75	813 89ea
3926	4.75	813 89ea
3928	4.75	813 89ea
3930	4.75	813 89ea
3932	4.75	813 89ea
3934	4.75	813 89ea
3936	4.75	813 89ea
3938	4.75	813 89ea
3940	4.75	813 89ea
3942	4.75	813 89ea
3944	4.75	813 89ea
3946	4.75	813 89ea
3948	4.75	813 89ea
3950	4.75	813 89ea
3952	4.75	813 89ea
3954	4.75	813 89ea
3956	4.75	813 89ea
3958	4.75	813 89ea
3960	4.75	813 89ea
3962	4.75	813 89ea
3964	4.75	813 89ea
3966	4.75	813 89ea
3968	4.75	813 89ea
3970	4.75	813 89ea
3972	4.75	813 89ea
3974	4.75	813 89ea
3976	4.75	813 89ea
3978	4.75	813 89ea
3980	4.75	813 89ea
3982	4.75	813 89ea
3984	4.75	813 89ea
3986	4.75	813 89ea
3988	4.75	813 89ea
3990	4.75	813 89ea
3992	4.75	813 89ea
3994	4.75	813 89ea
3996	4.75	813 89ea
3998	4.75	813 89ea
4000	4.75	813 89ea

NO P.O. BOX SHIPMENTS

**Diskette Storage BOX**  
HARD PLASTIC

5 1/4 inch -> 2pcs \$5.00 (SRW)

8 inch -> \$4.75ea.

**Bare Bones APPLE II**

w/o Keyboard = 48K RAM = \$450.

w/o Pwr. Supply

Microswitch: \$79.95  
Power Supply: \$124.00  
Apple: \$18.00

**Diskette SALE!!**

"Wabash"

5 1/4 8inch

SS/SD \$22.00 \$25.00  
SS/DD 27.40 30.40  
DS/SD 0 34.90  
DS/DD 32.40 37.40

**REAL-TIME CLOCK CALENDAR (MSM 5832)**

Descript: Mono Metal Gate CMOS IC

Features:  
Time Month Date Year. &  
Day of Week  
Bus Oriented  
1 Bit Data Bus  
1 Bit Address  
R/W Hold Select  
Interf Signal  
32 768KHz stal Control  
5v Pow Sup  
Low Power Dissipation

\$6.45  
W/SPEC:  
XTAL \$1.50



# Welcome to the third dimension

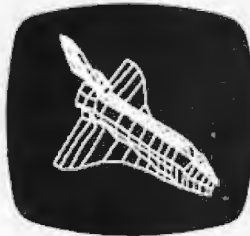

	Apple II*	IBM Personal Computer**
3 Axis Space Tablet (software included)	\$475.00	-
4 Axis Space Tablet (software included)	\$595.00	\$595.00
VISA, MasterCard and C.O.D.'s accepted. CT residents add 7.5% Sales Tax.		
*Minimal Configuration: 48K, Applesoft, DOS 3.3		
**Minimal Configuration: 64K, Game paddle adapter, color/graphics adapter		

Apple and Apple II are Trademarks of Apple Computer, Inc.

## in computer-aided graphic design.

Introducing The Space Tablet™ from Micro Control Systems. The first three-dimensional spatial digitizer compatible with Apple II™ and IBM Personal Computers.

The Space Tablet lets you interactively record x, y and z coordinates of any object—even one that doesn't really exist—then allows you to manipulate any or all of those coordinates with the push of a button. A fast, practical way to play "what if?" in any design situation.

What's more, specially written software allows you to rotate and rescale drawings instantly—or even compose one drawing from several components. All at a fraction of the price you'd expect to pay.

Applications for The Space Tablet are truly unlimited. Design. Engineering. Architecture. Science. CAD/CAM. Graph reading. And so much more. It can even be used as a two-dimensional digitizer.

Let us help you enter the third dimension in graphic design. Call or write and we'll tell you how The Space Tablet can work for you

**Micro Control Systems,  
230 Hartford Turnpike, Vernon, CT  
06066, (203) 872-0602.**

# MCS

Circle 420 on inquiry card.

decimal C060 is one of the addresses that would generate an interrupt. Because the cassette-input routine is a critical timing loop, interrupts make the adaptive-firmware card incompatible with the use of cassettes; therefore, don't use the card in a cassette-based system. The problem doesn't exist with a disk system.

### Serial Processing and the Disk

The current version of the card performs serial processing using the 6502 and a software routine. This generally requires a direct-interrupt capability in order to implement the timing necessary to handle the serial input data. A direct-interrupt capability, however, can interfere with disk activity and could be catastrophic if it occurred during a disk-write routine.

A flag is provided, with the serial-input routine, that is set to READY each time the card is enabled and is set to BUSY whenever the program exits from the card. As a result, input is only allowed to the card when the

card is active and the disk, therefore, is not. This still leaves a slight possibility that serial-input data could come in immediately after the flag is set to READY and the card is shutting itself down. A direct interrupt that would reenable the card at this point would cause no problem because the card would barely have been deactivated, and there wouldn't be sufficient time to get into a disk-read cycle.

### Some Aids Don't Have BUSY

Some serial-output aids do not have BUSY lines and thus would not heed the BUSY signal. This would lead to the aids' interrupting the computer at random, possibly during disk-read cycles. To avoid this situation, the card generates a second signal that totally closes down the interrupt capability of the serial line  $\frac{1}{10}$  second after the card is disabled. This is long enough to allow any close-following serial input to be picked up and processed (by enabling reading of

the firmware card) but not long enough to allow the computer to get itself to the point of writing to disk.

### Conclusions

With a little finagling, an adaptive-firmware card can be developed at low cost that can provide essentially transparent control of a microcomputer while offering a wide range of input algorithms to accommodate disabled individuals with varying physical abilities. In order to achieve this result, however, it is necessary to take advantage of traits unique to the microcomputer. As a result very few, if any, of the specifics of the board for the Apple II would be transportable to other systems. The system, by its very nature, is also not fully transparent.

However, for those individuals who have Apple II microcomputers and who want access to standard software programs, using one of the input techniques supported by the adaptive-firmware card, the card can provide an effective, flexible, and relatively low-cost solution. ■

# WICAT

**minicomputer  
performance at  
microcomputer prices**

**System 150** This popular and powerful desktop computer is well suited for business, scientific, or engineering applications. Its IEEE MULTIBUS™ structure and optional IEEE 488 instrumentation interface allow a wide variety of peripherals to be used.

**System 100** This high performance companion of the System 150 can be expanded to 32 intelligent ports and large capacity SMD disk drives

**Software** Concurrent's integral™ database and menusem™ greatly accelerate the development of applications. Full UNIX™ System 3 with no compromises is ready

Concurrent can discuss your needs and help you select the proper configuration. Please write or call (513) 281-1270.



Motorola 68000, 256K memory, 10MB Winchester disk, 760KB floppy, terminal, system software, choice of Pascal, FORTRAN, C, Assembler, BASIC, COBOL

Single user 150-1 . . . . \$ 9,450  
Three users 150-3 . . . . \$10,850  
Six users 150-6(512K) . \$12,850

MULTIBUS is a trademark of INTEL Corporation  
UNIX is a trademark of Bell Laboratories  
OPTIONS: graphics, printers, IEEE 488 instrumentation interface, videodisk controllers, A/D boards



**Concurrent** Corporation  
1870 Madison Road Cincinnati, Ohio 45206

*For additional information on the adaptive-firmware card, please send a self-addressed, stamped envelope to:*

*The Reprint Service  
Trace Research and  
Development Center  
314 Waisman Center  
University of Wisconsin  
Madison, WI 53706.*

*The original firmware card was developed in conjunction with the Maplewood School Computer Project, Edmonds, Washington. Assistance in the final development and dissemination of the adaptive-firmware card has been provided by the Trace Center's Commercial Facilitation Program, University of Wisconsin, under funds provided by Cerebral Palsy Inc., of Green Bay, Wisconsin, and Grant G008200049 of the National Institute of Handicapped Research, U.S. Department of Education.*

# PERIPHERAL · VISION ·

**F**LOPPY DISK SERVICES is a contracted dealer for Siemens disk drives. All drives are brand new & fully warranted against defects. Siemens is one of the most quality-oriented & respected manufacturers of disk drives, and once you see how well they perform with your system, you'll understand how they've gained their reputation among serious computer enthusiasts.

Apple Add-on Drives  
\$375.00 complete.  
Controllers & DOS  
available

WE HAVE ADD-ON 5 1/4"  
DISK DRIVES FOR THE  
IBM PERSONAL  
COMPUTER

CDR controller card for  
HEATH. Run any combo  
8" or 5" soft sector.

EXACT REPLACEMENT  
OR ADD-ON HEATH DISK  
DRIVES NOW AVAILABLE

SIEMENS DISK DRIVES  
FOR ALL  
APPLICATIONS

FDD-100-5a - standard  
40 track 'flippy' \$235.00

FDD-200-5 - double  
sided 40 track \$250.00

FDD-221-5 - double  
sided 96 TPI \$350.00

FDD-100-8d - single  
sided 8 inch \$340.00

FDD-200-8p - double  
sided 8 inch \$455.00

Our 5 1/4" track drives  
are the same ones used  
by HEATH, but look at  
the prices.

SIEMENS drives work  
perfectly with your S-  
100, Radio Shack MOD  
I, II, III, OSI, HEATH, IBM,  
North Star and many  
many more!

all drives are brand  
new and warranted. We  
are a contracted  
SIEMENS dealer

we have custom en-  
closures for both 5 1/4"  
and 8 inch drives, call  
we carry spare parts  
for SIEMENS drives. Call  
manuals available for  
all drives

custom made data  
cables . . . call.

WINCHESTER HARD  
DISK SYSTEMS

10 MEGABYTE Hard Disk  
systems for your HEATH  
H-88, 89, Radio Shack

Mod I, II, or III, Apple, IBM,  
or any S-100 system! You  
get a 10 megabyte  
formatted hard disk,  
power supply, cabinet,  
all interfacing cables,  
and CP/M boot loader.  
Most of all its all factory  
preassembled and tested,  
burned in and ready to  
run! You even get a real  
time clock (except  
HEATH). Built only of  
commercial grade  
components  
JUST \$2700 10mb

**A**T FLOPPY Disk Services, we not only sell drives, we also sell custom enclosures. Our cabinets are designed by our experts to be functional and attractive. And our quantity pricing is so attractive, we invite dealers and large group purchasers to call.

CALL TODAY • 609-771-0374



**I**F you don't see what you want, give us a call between 9 am & 5 pm (ET). Chances are we'll have what you need for your system at your price. Due to production deadlines for advertising, prices in this ad are 2 months old, so we encourage you to call us for current prices and new product information

**PAYMENT POLICY** - We accept Mastercard, VISA, personal checks & MO. We reserve the right to wait 10 working days for personal checks to clear your bank before we ship. All shipping standard UPS rates plus insurance. NJ residents must add 5% sales tax 3% charge for credit card use.

PRICES & SPECIFICATIONS SUBJECT TO CHANGE

**FLOPPY  
DISK  
SERVICES** INC.  
C.N. 5212  
PRINCETON, NJ 08540

MOD I-III, CP/M are trademarks of Tandy and Digital Research respectively

# OUR PRICES, SELECTION AND SAME-DAY SHIPPING MAKE US COMPETITIVE.

## Red Baron. Home of the Nation's

### NEC 8023 Outstanding Graphics, Print Quality & Performance



144 x 160 dots/inch • Proportional Spacing  
• Lower case descenders • N x 9 dot matrix  
• 8 character sizes • 5 unique alphabets  
• Greek character set • Graphic symbols  
• 100 CPS print speed • Bi-directional logic-seeking  
• Adjustable tractors • Single-sheet friction feed • Vertical & horizontal tabbing  
NEC 8023  
Dot Matrix ..... List \$795 **\$Call**

### IDS Paper Tiger Prism 80/132 Affordable Color, Speed



Dot Resolution Graphics • 9-wire staggered printhead • Lowercase descenders • Over 150 CPS • Bi-directional, logic-seeking  
• 8 character sizes • 80-132 columns  
• Proportional spacing • Optional Color  
• Text justifications  
Prism 80 ..... Base List \$999 **\$Call**  
Prism 132 (Color) Base List \$1,299 **\$Call**

### NEC Spinwriter 7700 & 3500 Daisy Wheel Quality Leader



High speed, letter quality • 55/35 CPS  
• Typewriter quality • Bi-directional printing & proportional spacing • Quiet • OCR quality print • Hi-res plotting/graphing • Quick change ribbon • Optional cut-sheet feeder, horizontal or bidirectional tractors • Prints up to 8 copies.  
NEC Spinwriter RO  
Serial Parallel 77xx .... List \$3055 **\$2575**  
35xx .... List \$2290 **\$1900**

### Smith Corona TP-1 Daisy Wheel Printer For Under \$900



Letter quality • Standard serial or parallel data interface • Drop-in ribbon • 144 WPM • Various fonts available • Loads paper like typewriter • Handles single sheets for forms

Smith Corona TP-1 ..... List \$895 **\$Call**

### The Epson Series High-Quality Printers at a Low Price.



Epson MX80 ..... List \$845 **\$Call**  
Epson MX80FT ..... List \$745 **\$Call**  
Epson MX-100 ..... List \$995

Full Line of Epson Accessories

### Brothers HR-1 Daisy Wheel Perfect for quality, quiet word processing.



• 16 CPS • Prints up to 6 copies • Bidirectional • Cloth or carbon quick-change cassette ribbon • Quiet, efficient operation for word processing •

Brothers HR-1 (Parallel) List \$1,100 **\$Call**  
Brothers HR-1 (Serial) . . . List \$1,200

### Anadex Silent Scribe The Quiet Serial Matrix Impact Printer



Up to 200 CPS • Dot addressable graphics • Parallel and serial interfaces standard • Switch selectable protocol • Cartridge ribbon • Switch character sets • Underlining • 1.5K to 3.5K buffer • Correspondence quality print

Anadex DP-9500A ..... List \$1,725 **\$Call**  
Anadex DP-9620A ..... List \$1,845  
Anadex DP-6000 ..... List \$3,250

### Televideo CRT's Price, Performance & Reliability



910 ..... List \$699 **\$Call**  
925 ..... List \$995 **For low Prices**  
950 ..... List \$1195

### Interface Equipment

Complete Stock of Options,  
Cables and Accessories.

CCS APPLE SERIAL Interface & Cable . \$160  
ORANGE INTERFACE for Apple II  
Parallel Interface Board & Cable ..... \$90  
NOVATION CAT Acoustic Coupler. .... \$175  
NOVATION D-CAT  
direct connect modem ..... \$180  
COMPLETE STOCK OF EPSON  
ACCESSORIES ..... \$Call  
CUSTOM PRINTER CABLES FOR Apple,  
Ateri, IBM, TRS-80 (all models) ..... \$Call  
HAYES MICROMODEM ..... \$300  
PRINTER STANDS: Large ..... \$99  
Small ..... \$25  
PRINTER RIBBONS—Most Types ..... \$Call

# OUR PEOPLE MAKE US EXPERTS.

## Largest Computer Printer Inventory.

### The Grappler+™ Apple® Graphics Interface

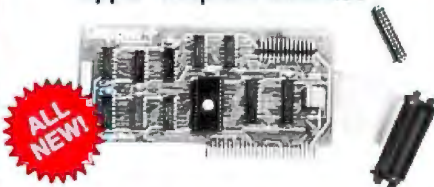

- Graphic and text screen dumps • Dual Hi-Res Graphics • Printer Selector Dip Switch • Apple III compatible\* • Inverse Graphics • Emphasized Graphics • Double Size Picture 90° Rotation • Center Graphics • Works with Pascal and CPM® • No software needed

Grappler+ ..... **\$175**

\* Requires software driver  
Apple is a registered Trademark of Apple, Inc.

### The Okidata Series Hi-Res or TRS 80 Block Graphics



- 120 CPS • 9 x 9 Matrix • Bidirectional logic seeking printing • Lower case descenders • four print styles • Optional Hi-Res Graphics

Okidata 82A ..... List \$649 **\$Call**  
Okidata 83A (w/Tractor) . . . List \$995

### IDS Microprism 480 Prints like a daisy, priced like a matrix!



- Correspondence Quality in a Single Pass • Dual Speed 75, 110cps • Proportional Spacing • Bidirectional Logic Seeking Head • Platen pin or pressure lead • 24x9 dot matrix • 10, 12, 16.8 Characters per inch • Double width Characters

IDS Microprism 480 . . . List \$799 **\$Call**

### Our People, Our Product: Both Are Specialized.

Because our salespeople are printer specialists, they know the capabilities of each printer—and how to match one to your exact need. Red Baron's volume stocking assures a low, low price on a wide array of major brands. We're sure you'll like the product and services you get from Red Baron, and we know you'll love our Customer Benefit Package; an exclusive at Red Baron.



### Customer Benefit Package

- 1. Free Expert Consultation.** Before you buy, after you buy.
- 2. Technical Staff.** Even your most involved questions get quick, helpful answers from our staff of printer technicians.
- 3. Free Catalog.** Get your informative catalog with printer comparison chart and print samples today!
- 4. Warranty.** The manufacturer's warranty applies where applicable.
- 5. Same-Day Shipping.** Your order is shipped the same day when you call before 11:00 a.m.
- 6. Free MasterCard and Visa.** Call us toll-free and charge your printer to your credit card.
- 7. We Stock What We Sell.** No bait and switch, no hassle. We make every effort to keep a large stock of our advertised products.
- 8. APO/FPO Orders Welcome.**

### Other Quality Printers at Red Baron

C. Itoh 8510  
Prowriter ..... \$795 **\$Call**  
C. Itoh F-10 ..... \$1995 **\$Call**  
Diablo 630/6 . . . \$2995 **\$2570**

### Here's How To Order:

Phone orders are welcome; same-day shipment on orders placed before 11:00 a.m. Free use of MasterCard and Visa. COD's accepted. Personal checks require 2 weeks clearance. Manufacturer's warranty included on all equipment. Prices subject to revision.

### Call Toll Free For Catalog:

**(800) 854-8275**  
CA, AK, HI (714) 630-3322



Circle 408 on inquiry card

1100 N. TUSTIN #207, ANAHEIM, CA 92807

# Letters, Pascal, CB/80, and Cardfile

*Jerry gives one man's opinions on a variety of subjects  
that interest computer users.*

---

Jerry Pournelle  
c/o BYTE Publications  
POB 372  
Hancock, NH 03449

---

"You're going to regret that silly column," my mad friend used to say. "People won't really read it. They'll sort of read it and then send you nasty letters refuting things you didn't say, and they'll be indignant about it, too."

"Come on, you encouraged me to write this column!"

"So I did."

"So what do I do?"

"Give me the letters. I'll help you answer them."

My mad friend was right in his prediction but alas cannot help me with the mail. Fortunately, things aren't as gloomy as he predicted. Some of my mail is reasonable and informative, and a lot more is at least informative. . . .

What, though, do I do with the letter that begins "I thoroughly enjoyed your column of xxx, but have you tried a Frammistan 9 running at 6.7 MHz with the model 3853.47 I've had one for five months and never had a glitch. . . .?"

While I'm grateful for descriptions of systems I haven't access to, I can hardly write about them; by its very nature this column has to concentrate on equipment I have and programs I

either use or tried and didn't like. Now I know in a sense this is unfair. In an ideal world I'd have nothing to do but play about with computers and programs and write absolutely unbiased accounts complete with benchmark times and bug reports; but this isn't an ideal world.

There's a limit to the time I can spend bopping about with computer

---

**If you're wondering  
why I didn't answer  
your letter—read on.**

---

systems, the number of computer systems I can own, and, indeed, the number I can use no matter how I get them. There's a limit to the number of programs I can review and the languages I can learn. These aren't limits I like very much—left to my druthers, I'd spend several hours a day playing with computer systems—but they're pretty absolute. I am primarily a book writer, and every now and then I have to deliver a book. There's no help for it. After that, my copious free time is divided among a number

of important—well I think they're important—activities. I am, for my sins, an official of the Science Fiction Writers of America; the secretary of the L-5 Society (an outfit you ought to join; send \$25 to L-5, 1620 E. Elm, Tucson, AZ 85719, and tell 'em I sent you); chairman of the Citizen's Advisory Council on National Space Policy; member of the Board of the Los Angeles Science Fantasy Society; and hikemaster of my local Boy Scout troop, and if you're wondering how any human being can do all that, so am I after listing it.

Now I'm not looking for pats on the back (in truth I ought to give up one or another of those activities since I can't give all of them the time they deserve), nor can I really excuse my inability to answer all my mail. But as they taught us way back when, there's never an excuse, but there may be an explanation, and if you're wondering why I didn't answer your letter, now you have an explanation.

The upshot is, of course, there are good hardware systems I have never described in this column. Some I never heard of, and even if I had, it's certain I can't buy every system that comes out. Some I have heard of,



WHEN AMERICAN BUSINESS HITS THE ROAD,  
AMERICAN BUSINESS PROFITS AT HILTON.



with sufficient negative comments so that I've little interest in further investigation—yet in fairness I can hardly span something I have no personal experience with. The bottom line is I don't at all mind your telling me about your favorite system or program, but do understand that I may never be able to write about it. That's not optimum, but I don't see what I can do. I really am dancing as fast as I can.

Now for specifics.

### Drive Along Little Doggie

Have I been too hard on 5¼-inch disk drives? A number of correspondents tell me I have. Some I can ignore, such as the reader who sent the letter accompanied by a catalog of software sold only on 5¼-inch disks—I don't ignore him because of the obvious self-interest, but because both the cover letter and the catalog are illiterate, making me wonder what the program documentation is like. But there are also sane letters.

The most rational says, "You do need two disk drives with at least 250K bytes of memory to do much of anything, and three drives are required to run many programs rationally . . . [but] a 5¼-inch [disk] is more convenient than and just as reliable as an 8-inch [disk]. Speed is slightly slower when transferring large files, but the difference is hardly noticeable during normal operator interaction. One 8-inch drive is nice to read the original CP/M disks, but the only real requirement is to pick something that Lifeboat supports. A hard disk is where we are all going anyway, and the basic requirement is to get programs in and data back out."

Let's look at this a chunk at a time. First, one 8-inch drive is silly; there are few power-supply cabinets built for a single 8-inch drive, and if you're going to get one, you might as well get two and be done with it. Incidentally, I still strongly recommend the Qume DT-8s; double-sided and double-density, they store over a

megabyte per disk, and with a Com-pupro controller, they're very fast. My friend Bill Grieb of System Interface Consultants has had good experience with Qume disks in the Integrand S-100 box, a package containing a seven-slot bus and two drives in a box smaller than the one my Cromemco Z-2 occupies without drives. The point is, if you're getting one 8-inch drive, you might as well get two. You just don't save that much money or space.

Second, my correspondent rightly states that you can't get along without top-of-the-line 5¼-inch disks: that is, disks that hold 250K bytes of memory and more, which is to say hold 40 tracks and are double density. Unfortunately, those aren't cheap. They are smaller than 8 inches, which is the only "convenience" I know of; but three of them take up only slightly less room than two DT-8s.

Third, my experience with 5¼-inch reliability is not his. True, I was working with experimental stuff in the Dark Ages (two years ago); thus, I might be wrong. The fact remains that a 5¼-inch disk is nothing more than the inner 40 tracks of an 8-inch system, and the inner tracks are the least reliable.

But to me the fatal flaw is the lack of any standard format in 5¼-inch disks. With 8-inch disks, CP/M is CP/M, and everyone can read each other's data files. Alas, that's not so with small disks.

Now it's true my Godbout system cannot read double-sided double-density disks created by my son's CCS (California Computer Systems), even though both use Qume DT-8 disk drives and, in general, each disk-controller manufacturer has his own double-density format that's unreadable by any other controller. However, nearly all 8-inch systems I know of can read IBM 128 bytes/sector, single-sided single-density disks, meaning that I have access to most of my friends' machines and they to mine. There's no comparable standard with 5¼-inch disks and thus communications are considerably hampered.

## INVESTMENT ANALYSIS FROM CENTENNIAL

CENTENNIAL SOFTWARE / 410 17TH ST. SUITE 1375 / DENVER, CO 80202 / (303) 595-9193

### STOCK-FOCUS

Find out how low is low and how high is high. Using capital structure and performance data, Stock-focus objectively calculates the underlying value of a stock. The system was first developed by the management science department of a major money center bank, and is now in use by investment advisors, trust companies and brokerage houses. On your screen, Stock-focus will plot an estimate of lowest value, highest value and the current price. You then decide what to buy, sell or hold.

### REAL-FOCUS

Exhaustively analyze potential real estate investments using the Wharton School's approach to real estate analysis. In minutes you can project profit, costs, and IRR for any project over a 10 year period. Real-focus accounts for amortization, debt, income, operating expenses, taxes, depreciation, and cash flows for both after-tax holding and the results of sale. With Real-focus you can analyze any potential investment from a single building project to a complex time-phased planned unit development.

### THE FOCUS TECHNIQUE

FOCUS is CENTENNIAL SOFTWARE's new approach to Program Architecture, providing a natural interaction between microcomputers and users. It provides worksheet style input screens, free access to all program segments, and the ability to com-



bine individual results files for portfolio analysis. You also receive a usable reference manual, menu helps, a program glossary, multiple report formats and spooling. With our FOCUS technique even the most complex programs are versatile and easy to use.

COMPUTER	MEMORY-K	REAL-FOCUS	STOCK-FOCUS
IBM PC	64	\$179.00	\$189.00
Apple (plus) II	48	149.00	159.00
TRS-80 I	48	149.00	159.00
TRS-80 II	64	179.00	189.00
TRS-80 III	48	149.00	159.00

### ALL PROGRAMS IN DISK BASIC

IBM is a trademark of IBM, Apple is a trademark of Apple Computer Corp., TRS-80 is a trademark of Tandy Corporation

**ORDER NOW! FILL IN OR CALL 800-525-2003 (Toll Free)**

PROGRAM NAME \_\_\_\_\_ COMPUTER \_\_\_\_\_ MEMORY \_\_\_\_\_  
 NAME \_\_\_\_\_ PHONE # \_\_\_\_\_  
 ADDRESS \_\_\_\_\_      
 ACCOUNT # \_\_\_\_\_ EXP. DATE \_\_\_\_\_



# COMPUTER WAREHOUSE

**CALL TOLL FREE 1-800-528-1054**

**INTERNATIONAL INQUIRIES INVITED**

## ATARI

**Special 32K 800 System**  
800 w/32K, recorder, Pac Man OR star  
raiders, joysticks... **Call**  
Above w/48K... **Call**

800 (16K).....	<b>\$670</b>
400.....	<b>Call</b>
810 Disk Drive.....	<b>\$440</b>
825 Printer.....	<b>\$590</b>
850 Interface.....	<b>\$170</b>
410 Recorder.....	<b>\$75</b>
830 Modem.....	<b>\$155</b>
16K Memory.....	<b>\$60</b>
32K Memory.....	<b>\$90</b>
80 Column Board.....	<b>Call</b>

## DISK DRIVES

**Lobo**

Apple 1st Drive.....	<b>\$400</b>
Apple 2nd Drive.....	<b>\$350</b>

**Percom**

Atari D/D Drives.....	<b>Call</b>
-----------------------	-------------

## PRINTERS

Anadex.....	<b>Call</b>
Anacom.....	<b>Call</b>
C. Itoh	
F-10—Parallel.....	<b>Call</b>
F-10—Serial.....	<b>Call</b>
55CPS—Series.....	<b>Call</b>
Prowriter.....	<b>Call</b>
Tractors for starwriter.....	<b>\$147</b>

**Comrex**

CR-1-S.....	<b>Call</b>
CR-1-P.....	<b>Call</b>
CR-1-Q.....	<b>Call</b>

**Datasouth**

DS 180.....	<b>\$1260</b>
-------------	---------------

**Diablo**

620 RO wo/ Tractors.....	<b>Call</b>
630 RO wo/Tractors.....	<b>\$2050</b>
630KSR wo/Tractors.....	<b>\$2435</b>

**Epson**

MX-80.....	<b>Call</b>
MX-80 F/T.....	<b>Call</b>
MX-100.....	<b>Call</b>

**Integral Data Systems**

Prism 80.....	<b>Call</b>
Prism 132.....	<b>Call</b>

**NEC**

PC-8023A.....	<b>Call</b>
3510.....	<b>Call</b>
7710.....	<b>Call</b>
7720.....	<b>Call</b>

**Okidata**

Microline 80.....	<b>\$305</b>
Microline 82-A.....	<b>\$400</b>
Microline 83-A.....	<b>\$650</b>
Microline 84.....	<b>Call</b>

**Tally**

1805/1802.....	<b>\$1555</b>
1605/1602.....	<b>\$1325</b>

**Texas Instruments**

810 Basic.....	<b>Call</b>
----------------	-------------

## MONITORS

**Zenith**

12" Green Screen.....	<b>\$115</b>
-----------------------	--------------

**Amdek**

Video 300.....	<b>Call</b>
Color I.....	<b>Call</b>
Color II.....	<b>Call</b>
Color III.....	<b>Call</b>

**Comrex**

13" RGB Color.....	<b>\$460</b>
--------------------	--------------

**FREE SHIPPING**  
on  
all U.P.S. shipments

## SPECIAL VISICALC SYSTEM

Franklin Ace 100, Lobo 1st Drive,  
Zenith Green Screen Monitor, Visicalc... **\$1800**

## VIDEO TERMINALS

<b>Adds</b>	
Viewpoint.....	<b>\$490</b>
<b>Soroc</b>	
IQ 120.....	<b>Call</b>
IQ 130.....	<b>Call</b>
IQ 135.....	<b>Call</b>
IQ 140.....	<b>Call</b>
<b>Televideo</b>	
910.....	<b>\$570</b>
912.....	<b>\$675</b>
920.....	<b>\$735</b>
925.....	<b>\$730</b>
950.....	<b>\$915</b>
<b>Zenith</b>	
Z-19.....	<b>\$680</b>
ZT-1.....	<b>Call</b>

## DISKETTS

<b>Elephant</b>	
5 1/4" 0. Sector (100).....	<b>\$215</b>
<b>Maxell</b>	
5 1/4" 0. or 10. Sector (100).....	<b>\$250</b>

## SOFTWARE

WordStar.....	<b>\$275</b>
Mailmerge.....	<b>\$85</b>
SpellStar.....	<b>\$140</b>
DataStar.....	<b>\$195</b>
CalcStar.....	<b>\$175</b>

## COMPUTERS

<b>Altos</b>	
ACS 8000-15.....	<b>\$3742</b>
ACS 8000-2 w/CPM*.....	<b>\$2650</b>
Series 15D.....	<b>\$2250</b>
Series 5-5D.....	<b>Call</b>
California Computer Systems.....	<b>Call</b>
<b>Commodore</b>	
VIC-20.....	<b>\$239</b>
<b>Dynabyte</b> .....	<b>Call</b>
<b>NEC</b> .....	<b>Call</b>
<b>Northstar</b>	
Advantage.....	<b>Call</b>
Horizon II 64K QD.....	<b>\$2625</b>
<b>Sanyo</b> .....	<b>Call</b>
<b>Televideo Systems</b>	
TS-802.....	<b>Call</b>
TS-802H.....	<b>Call</b>
<b>Zenith</b>	
Z-90 64K w/CPM*.....	<b>\$2385</b>

## MODEMS

<b>Novation</b>	
CAT.....	<b>\$140</b>
D-CAT.....	<b>\$155</b>
Apple Cat II.....	<b>\$349</b>
Auto Cat.....	<b>\$235</b>

## MOUNTAIN HARDWARE

All products... **Call**

## HOUSTON INSTRUMENTS

<b>Hi-Plot</b>	
DMP-2.....	<b>\$825</b>
DMP-7/8.....	<b>\$2025</b>



2222 E. Indian School Rd.  
Phoenix, Arizona 85016  
Order Line: 1-800-528-1054  
Other Information: 602-954-6109

**Store Hours: Mon.-Fri. 10-5 MST  
Saturday 9-1 MST**



Prices reflect 3% to 5% cash discount. Product shipped in factory cartons with manufacturer's warranty.

Personal checks will delay shipping two weeks. Prices & availability subject to change without notice.

# PERSONAL COMPUTERS PERSONAL COMPUTERS PERSONAL COMPUTERS

OKIDATA MICROLINE 83A

**\$695.00**



120 CPS, Bi-directional logic seeking 9x9 dot matrix, full 96 ASCII char. Set with true descenders centronics parallel port and RS232 serial port (up to 1200 Baud) standard, 136 col, includes Okigraph dot addressable graphics, friction feed and removable tractor. 31 lbs., 110 volt standard, 220 volt optional.

	Call for Model & Price
Altos .....	149.00
Amdek Video-300 .....	329.00
Amdek Color-I Monitor .....	729.00
Amdek Color-II Hi-Resolution 13" Monitor .....	439.00
Amdek Color-III Monitor .....	319.00
Atari 400 16K .....	449.00
Atari 810 Disk Drive .....	169.00
Atari 850 Interface .....	669.00
Atari 800 16K .....	1049.00
Daisywriter 2000 .....	2095.00
Diablo 630 .....	289.00
Epson MX-70 .....	439.00
Epson MX-80 w/Grafrax Plus .....	549.00
Epson MX-80 FT w/Grafrax Plus .....	695.00
Epson MX-100 FT Printer w/Grafrax Plus .....	289.00
Hayes Micromodem II (Apple II) .....	225.00
Hayes Smartmodem .....	1099.00
IDS 560 Paper Tiger .....	1379.00
IDS Prism 80 (Color) .....	1559.00
IDS Prism 132 (Color) .....	1289.00
Mannesmann Tally MT 1705 .....	1499.00
Mannesmann Tally MT 1802 .....	79.00
Microtek 16K Ramboard for Atari 800 .....	119.00
Microtek 32K Ramboard for Atari 400 & 800 ..	279.00
Microsoft Soft Card (Z-80) .....	579.00
Microsoft Soft Card Premium System for Apple	369.00
Microsoft Ramcard 64K for IBM-P.C. ....	139.00
Microsoft Ramcard 16K for Apple .....	1675.00
NEC 3510 or 3530 Spinwriter .....	1695.00
NEC 3515 Spinwriter .....	2295.00
NEC 7710 or 7730 Spinwriter .....	489.00
NEC PC-8023 Printer .....	329.00
NEC JC1201 M(A) - Color 12" Monitor .....	169.00
NEC GREEN JB1201M - 12" Monitor .....	

**CALL TOLL FREE!**  
**800-343-0873**

Okidata Microline - 80 Matrix Printer .....	329.00
Okidata Microline - 82A .....	449.00
Okidata Microline - 83A .....	729.00
Okidata Microline - 84 Parallel .....	1095.00
Sharp PC-1500 Pocket Computer .....	239.95
Sharp CE-150 Color Printer/Cassette I/F ....	199.95
Sharp PC-1211 Pocket Computer .....	135.95
Sharp CE-122 Printer/Cassette Interface for PC-1211 .....	99.95
Smith-Corona TP-1 .....	649.00
Televideo 910 .....	559.00
Televideo 925 .....	735.00
Televideo 950 .....	929.00
Transtar Model 140 .....	1295.00
Videx Videoterm 80 Column Card for Apple II .	259.00

## OMEGA SALES COMPANY

430 PEARL STREET, STOUGHTON, MA 02072

**(617) 344-6645 TOLL FREE (800) 343-0873**

**EPSON MX-100 FT**

**\$695.00**



**OMEGA DELIVERS  
FOR LESS**

**OKIDATA MICROLINE 83A  
OR  
EPSON MX-100 FT**

**YOUR CHOICE  
\$695.00**

80 CPS, Bi-directional logic seeking 9x9 dot matrix, full 96 ASCII char. Set with true descenders, centronics-style parallel port (RS232 optional), 136 col., includes grafrax plus dot addressable graphics, friction feed and removable tractor feed. 21 lbs., 110 volt only.

#### **SOFTWARE**

Omega carries software by the following companies:

- American Business Systems • Ashton Tate • Dakin 5
- Innovative Software • Micropro • Microsoft
- Sorcim • Stoneware • Visicorp (Personal Software)

#### **MAGNETIC MEDIA**

Omega carries diskettes (5¼" or 8") by the listed companies:

- Dysan • Maxell • Scotch • Verbatim

#### **ACCESSORIES**

Omega carries accessories for the Apple II by the following manufacturers:

- D.C. Hayes • Microsoft • Tymac
- M & R Enterprises • Videx

**CALL TOLL  
FREE!  
800-343-0873**

Stock Shipments Same Day or Next  
No Surcharge for Credit Cards  
All Equipment Factory Fresh w/MFT Warranty  
Prices do not Reflect Shipping Charges  
Mass. Residents Please Add 5% Sales Tax

**PRICES ARE SUBJECT TO  
CHANGE WITHOUT NOTICE**

We carry the complete line of Atari Hardware, Software & Peripherals.

We will try to match or beat any price with similar purchase conditions.

**OMEGA SALES COMPANY**

430 PEARL STREET, STOUGHTON, MA 02072

**(617) 344-6645 TOLL FREE (800) 343-0873**

## Scotch Diskettes

Rely on Scotch® diskettes to keep your valuable data safe. Dependable Scotch diskettes are tested and guaranteed error-free. The low abrasivity saves your read/write heads. They're compatible with most diskette drives.



**(800)235-4137**

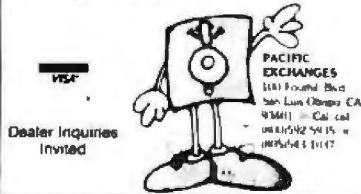

PACIFIC EXCHANGES  
181 Fourth Blvd  
San Luis Obispo, CA  
93401 • Cal. cal  
0810/92 5415 •  
0825/84 4147

Dealer Inquiries  
Invited

Circle 358 on Inquiry card.

## THIN is IN!

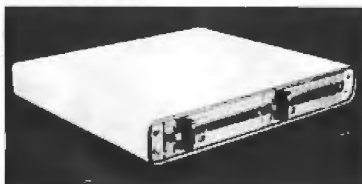

State-of-the-art 8" disk drive subsystems give you a remarkable 2.4 MB in the space of a single-drive cabinet, 4.8 MB storage capacity in the space of a 2-drive cabinet. Perfect add-ons for IBM, Apple, Radio Shack and all 8" Shugart compatible computers.

Systems	Introductory Price	Retail
2-Drive	\$1695	\$1995
4-Drive	\$2995	\$3495
2-Drive Horizontal	\$1750	\$2050

write protect switch option — \$30/drive

**Columbia microSystems, Inc.**  
905 E. Broadway, Columbia, MO 65201  
(314) 875-8900

Circle 90 on Inquiry card.

## Elegant Calculations with EASYPAK™

EASYPAK is a library of routines in FORTRAN-80 for performing scientific and mathematical functions including:

- Vector and Matrix Operations and I/O.
- Linear/Nonlinear Equations and Regressions.
- Optimized Least Squares.
- Eigenvalue/Eigenvector Problems.

EASYPAK includes interactive test programs.

EASYPAK (REL File): .....\$250.  
EASYPAK source code: .....\$365.

**BRIDGE**  
Computer Company  
DIVISION OF Sea Data Corporation  
One Bridge Street, Newton, MA 02158  
TEL. (617) 244-8190 TLX: 951107

Circle 65 on Inquiry card.

I agree that we're all headed for hard disks. The clutter here at Chaos Manor (I now face three sets of dual 8-inch disk drives plus two 5¼-inch disk drives plus a hard-disk drive) tempts me sometimes to reduce the size of everything; but I want more software than Lifeboat can supply, and I don't know what format of 5¼-inch disk to buy, so I'll stick with at least one pair of DT-8s, hard disk or not.

Finally, there's the safety factor. You may trust your hard disk, but as far as I'm concerned, my text isn't really safe until it's written onto a disk and the disk is put in a nonmagnetic metal box on the other side of the room. Little disks just don't hold enough text, nor do I have that much confidence in them.

All told, then, I'll stay with the big floppy disks.

## M & Ns and Are You a Compiler?

I've previously mentioned my Compupro M-Drive, which we've designated as drive "M" and Semidisk, which became drive "N." For the few who don't know, these are two different schemes for fooling your computer into thinking that a big block of memory is a disk drive. I doubt that I've sufficiently praised them. Both Compupro's M-Drive and the Semidisk system work so well that you don't notice them.

The Compupro system is marginally faster than Semidisk's, and the Compupro memory can be used as RAM (random-access read/write memory) for your 8088 when you use your 8085/88 that way; but the system requires a Compupro disk controller and an 8085/88 processor. Meanwhile, Semidisk is plenty fast and can be used with any CP/M 2.2 S-100 bus system, no matter what controller and processor are being used. And having them can change the way you do things.

There are times when I am willing to take Pascal and stuff the language into a culvert. There truly are times when I completely agree with my late mad friend, who thought Pascal useful for classroom exercises, particularly in places that didn't have

computers for the students to work with, but not much use for practical programming. Lately I've been helping my son Alex and his classmates work on the Workman and Associates' Pascal Introduction Package: they're taking standard programs out of standard textbooks, such as Peter Grogono's *Programming in Pascal* and the Kernighan and Plauger classic *Software Tools in Pascal*, and getting them to run with Digital Research's Pascal/MT+ and Sorcim's Pascal/M compilers. And the job is driving me nuts. Alex and his friends will *earn* every nickel they make.

Pascal really and truly expects the programmer to be a sort of precompiler. Consider error messages like "Error number 6: Illegal symbol (possibly missing ';' on line above)" and "Error number 51: '=' expected." Pascal/MT+ even shows you precisely where these errors are expected, and usually the compiler is right about the guesses, too.

So why don't the compilers simply supply the needed symbol? Especially when they found "=" where they expected ":="? Now it's true that you don't want to depend on compilers to do your thinking for you. You really ought to go correct the program. But I don't see why they can't give you the specific error message, plus say "following assumption implemented," and show you what they did, then continue with the compilation. That way they would catch nearly all the trivial errors in one pass, and then you could go back and correct them all at once rather than having to load the editor, add a semicolon, exit the editor, compile until the next trivial error, etc., ad nauseam.

We have both M and N drives (on the same machine; if you type in "PIP M:=N:\*.\"", the result is blindingly fast), and thus the cycle isn't so long for us. After all, the disk-access times are pretty short, so we're not waiting for the editor or the compiler to load or the editor to write to disk. I think I would probably have given up on Pascal without them.

It isn't just the trivial errors that make Pascal hard to use. Although the compiler's intolerance for trivial

# Peripherals

## Unlimited...

FANTASTIC PRICES!

OUR FAST SERVICE, PRODUCT SELECTION AND OUR CUSTOMERS' SATISFACTION MAKE US #1.

### ZENITH

Z-89-48K	\$2299
Z-90-64K DO	\$2588
Z-19 Terminal	\$777
Z-121 Monitor 12"	\$149

### EPSON PRINTERS

MX-80 w/Graphics	CALL
MX-80 FT (Friction + Tractor)	CALL
MX-100 (15" Carriage)	CALL

Call for prices on Ribbons, Cables and Interfaces

### ATARI COMPUTERS

Atari 800 16K	\$649
Atari 400	\$318
Atari Interface Module	\$174
Atari 810 Single Disk	\$444
Atari 830 Modem	\$166
Programmer	\$59
Entertainer	\$84
Star Raiders	\$34
16K Mem. Exp. for Atari	\$74
32K Mem. Exp. for Atari	\$114

### NEC-PC 8000

#### Series Microcomputer

PC-8001A Computer w/32K	\$888
PC-8012A w/32K + Exp. Slots	\$588
PC-8031A Dual Mini Disk	\$888
PC-8032A Add-on Mini Disk	\$777

Call for Software Prices

### NEC PRINTERS

7710/30 Spinwriter R/O	CALL
7720 Spinwriter KSR	CALL
3510/30 Spinwriter R/O	CALL

### NEC DOT MATRIX

PC-8023	\$474
---------	-------

Call for prices on ribbons, etc.

### MORE PRINTERS

Anadex 9500/9501	\$1295
Anadex DP-9000	\$1049
Okidata Microline 82A	CALL
Okidata Microline 83A	CALL
Okidata Microline 84	CALL
Tractor (OKI 80 + 82 only)	\$60
Diablo 630	\$2044

### MONITORS

Sanyo 12" GRN Phosphor	\$266
Sanyo 12" Black + White	\$239
Amdek 12" 300 GRN Phosphor	\$149
Amdek 12" Color	\$319
Amdek Color II	\$779
NEC 12" GRN Phosphor	\$164
NEC 12" Color	\$344

FOR THE LOWEST  
PRICE CALL  
**TOLL FREE**  
**1-800-343-4114**

### ORDERING INFORMATION

Our order lines are open 9AM to 6PM EST Monday thru Friday. Phone orders are welcome; same day shipment on orders placed before 10AM. Free use of Mastercard and VISA. Personal checks require 2 weeks clearance. Manufacturer's warranty included on all equipment. Prices subject to revision. C.O.D.'s accepted.

For service, quality and delivery call:

**PERIPHERALS UNLIMITED**  
**(617) 655-7400**

62 N. Main St. • Natick, MA 01760

mistakes seems to me a mistake, one assumes that study and practice will overcome that. Nor am I certain precisely what is wrong; but here I'm watching students who've been working with Pascal for four years take hours and hours to debug programs copied from a standard textbook recommended by the compiler writer. That's portability?

I suppose I shouldn't complain. Alex expects to make a lot of money off his Pascal lessons. When he first started working on the concept, I wasn't sure it would be worth what Workman said he'd have to charge; but that was before I got involved in helping out: that is, Alex had some exams coming up, so I volunteered to type in a couple of Grogono programs and get them running. They were, after all, simple programs, and all that was needed was to copy them out of a book, to spend an hour or two typing, and perhaps to put in an hour debugging. . . .

Hah! Didn't work that way at all.

First, even with Semidisk it took longer than I'd have thought to get rid of all the trivial errors. Then the fun really began. There are more obscure errors and faults in Pascal than you can dream of, even if you spend weeks studying a good introductory text like Grogono's.

For example: "Error number 253: Procedure (or program body) too long. Reduce the size of the procedure and try again."

I searched the index in *Programming in Pascal*, Digital Research's Pascal/MT+ documentation, and Sorcim's Pascal/M document. Nary a word about this, or at least none I can find. Programs that will compile in Pascal/MT+ give you error 253 in Pascal/M. You fix that by shortening the program, which you can do by taking a number of messages that are delivered only once and putting them into a procedure (although it's a bit silly to call a subroutine just to read the instruction messages). Of course, the procedure was (trivially) wrong

the first couple of times. Then the random-number generator Grogono uses wouldn't work because he uses the integer 65536. Mike Lehman, who wrote Pascal/MT+, told me on the phone simply to change that to 65536.0, thus changing it into a floating-point number; but that doesn't work either, because Pascal will not do implicit type conversion, and we needed the MOD (get the remainder, or modulo) function, and Pascal won't let you do the MOD function unless you're dividing by an integer. . . .

So, we wrote a "get remainder" procedure, only that ran into conflicts of variable types.

Then we tried a different random-number generator and went through the Grogono program to document where and why we changed variables from integers to real numbers, and after about three times as much time and work as I'd expected, that program is done. There are a lot more like that in the package Alex did; and

## YOU CAN SAVE UP TO 40% WITH RCE WARRANTY/SERVICE . . . OUR SPECIALTY

LOOKING FOR A MAIL ORDER APPLE®?  
HAVE WE GOT SOMETHING FOR YOU!

**ORDER: 1-800-547-2492**

IN OREGON CALL

FOR TECHNICAL ASSISTANCE  
(503) 479-4711 or (503) 479-4150

**ATARI** 400 (16K) \$289  
800 (16K) \$665

EPSON w/GRAFTRAX I.D.S.

MX-80 \$439 560G Printer \$999  
MX-80FT \$539 Prism 80 w/color \$1249  
MX-100 \$699 Prism 132 w/color \$1549

RANA Controller - 4 Drives - \$119  
DRIVES Elite 1 - \$379 Elite 2 - \$499

### APPLE HARDWARE

MICRO SCSI DISK DRIVES (DIRECT APPLE REPLACEMENT)	
A 2 DISK DRIVE	\$349
A 70	\$469
A 40	\$349
CONTROLLER 3.5 & 3.2	\$79
CCS 710A SERIAL INT	\$139
CLS 710D SERIAL INT	\$139
VIDEX 80 COLUMN	\$239
VIDEX ENHANCER II	\$119
LOWER CASE ADAPTOR	\$39
16K RAM CARD	
MICROSOFT OR MPC	\$149
ALS	\$139
MICROTEK BAM I	\$99
2-80 CARD (MICROSOFT)	\$275
MICROMODEM (HAYES)	\$264
SMART WIREN (HAYES)	\$299
NOVATION MODEMS	
APPLE CAT	\$389
AUTO CAT	\$139
CAT	\$139
D CAT	\$139
MOUNTAIN CLOCK	\$239
MOUNTAIN MUSIC SYSTEM	\$309
MOUNTAIN A/D CONVERTER	\$269
MOUNTAIN INTR/LX-10 CARD	\$169
MOUNTAIN C.P.S.	\$149
800 25 KEYPAD	\$139
SUP-R-TERM (80 COLUMN)	\$299
SUP-R-MOD R.F. MODULATOR	\$24
JOYSTICK (T.G.)	\$45
12" B&W MONITOR (SANYO)	\$189
12" GREEN MONITOR (SANYO)	\$229
12" GREEN MONITOR (ZENITH)	\$119
12" GREEN MONITOR (BMC)	\$114
13" COLOR MONITOR (SANYO)	\$385
EPSON CABLE & INTERFACE	\$79
EPSON GRAFTRAX PLUS	\$75
POWERLINE PROTECTOR	\$39

### ATARI HARDWARE

410 PROGRAM RECORDER	\$75
810 DISK DRIVE	\$429
820 PRINTER	\$249
822 PRINTER	\$339
830 MODEM	\$149
850 INTERFACE MODULE	\$165
851 16K MEMORY EXPANSION	\$79
MICROTEK 32K	\$105

### SOFTWARE

VISICALC (ATARI)	\$179
BASIC (ATARI)	\$49
VISICALC	\$179
VISIDEX	\$179
VISIPILOT	\$145
VISITERM	\$75
VISITREND/PLOT	\$214
VISIPAC	\$499
DESK TOP PLAN #2	\$179
DESK TOP PLAN #3	\$214
MICROLAB DATA FACTORY	\$229
D B MASTER (STONEWARE)	\$179
SUP-R-TEXT II	\$109
WORDSTAR	\$349
B.F.I. SOFTWARE (each)	\$319
STOCK FILE INVENTORY	\$269
ZORK	\$35
SARGON CHESS	\$29
GALAXIAN	\$22
VERBATIM DISKS	\$29
MAXELL DISKS	\$38
THE SOURCE	\$85

MINIMUM ORDER--\$100.00 MINIMUM SHIPPING CHARGES--\$4.00

#### TERMS

SHIPPING: Add 3% of total transaction for UPS brown (ground) or 6% for UPS blue (air), Parcel Post, or any special arrangements.

PAYMENT: Cashier's checks, certified checks, money orders, and bank wires honored immediately. We transfer funds to U.S. National Bank of Oregon, South Grants Pass Branch. Credit RCE, account number 187-6501-980. Add 3% for Visa & Master Charge. Allow 30 days for personal checks to clear.

REFUNDS: 10% restocking charge on all returns or exchanges. No refunds on opened software. Call first.

GUARANTEE: All products with full manufacturer's warranty. Sanyo and Apple warranty available.

We have full repair and service facilities for all electronic repairs with HP, Dynascan, Pioneer, Sanyo and Apple trained and certified technicians. For any technical service call them for instant advice or questions right on their benches at (503) 479-4150.

REPAIRS: Out of warranty guarantee: Labor 30 days from date of your receipt, 90 days on parts. Call for details on quality guaranteed discount repair and reconditioning service.

We have been repairing electronic equipment for 12 years and love it!

**"A Unique Combination of Quality Products, Competitive Prices, and Service"**

PRICES SUBJECT TO CHANGE WITHOUT NOTICE  
WRITE FOR CATALOG

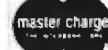

**RALSTON-CLEARWATERS ELECTRONICS**

536 N.E. 'E' Street • Grants Pass, Ore. 97526  
ALL BRAND NAMES ARE REGISTERED TRADE MARKS



# BISON PRODUCTS, INC.

A CALIFORNIA CORPORATION



## We're Bullish on Low Prices

Bison Products, Inc. carries most every product you could want for your business or personal computer - AND - we give them to you at prices that are LOWER than anyone else. COMPARE our total price for the equipment you want to anyone else's total price and you'll agree. If the items you want are not listed in this ad, call us for the current price. If you find an advertised price that is lower than ours, call us and we'll try to beat it.

**Send Mail Orders To:**  
P. O. Box 9078-184  
Van Nuys, California 91409

**Orders may be picked up at:**  
16709 Roscoe Boulevard  
Sepulveda, California 91343

**For Questions or Phone Orders Call:**  
(213) 891-5702

Most orders shipped within 48 hours or receipt of cash or certified check. VISA and MasterCard accepted. All merchandise new in factory cartons with manufacturer's warranties. Corporate and School District P.O.'s accepted subject to credit approval. Enclose financial statement with order. California residents add Sales Tax. Shipping charges added to all orders. For Further Information Please Circle Reader Service # 55

### COMPUTER SYSTEMS

NEC PC-8001A ..... \$725  
Commodore VIC 20 Personal Computer System ... \$239

#### Products For Apple Computers

Here are some of the products BISON carries for Apple Computers. If you don't see what you want here, give us a call

16K RAM Card for Apple II ..... \$ 58  
Videx Videoterm w/Softswitch ..... \$ 258  
Microsoft Z-80 Softcard w/CP/M ..... \$ 253  
BISON Disk Drive w/33 Controller ..... \$ 459  
BISON Add-on Disk Drive ..... \$ 349  
Parallel Printer Card with Cable ..... \$ 72  
D. C. Hayes Micromodem II ..... \$ 270  
Novation Apple Cat Modem ..... \$ 325  
For more Apple information, circle reader service card # 52

#### Products For IBM Personal Computers

Tandon Single-Sided Disk Drive ..... \$ 255  
Tandon Double-Sided Disk Drive w/DOS Patch .. \$ 485  
Tandon Double-Sided Drive  
w/80 Tracks & DOS Patch ..... \$ 595  
AST 64K RAM Card ..... \$ 365  
9-piece set of 64K RAMs ..... \$ 75  
For more IBM information circle reader service card # 53

### PRINTERS

BISON carries all of the major brands of printers. If you need help choosing the proper printer for your needs, call and talk to one of our support technicians

EPSON MX-80 Type III with Graftrax Plus ..... \$ 412  
EPSON MX-80 F/T Type III with Graftrax Plus ..... \$ 522  
EPSON MX-100 with Graftrax Plus ..... \$ 675  
NEC PC-8023A Friction & Tractor w/Graphics ..... \$ 485  
Okidata Microline 82A with Tractor - 80 Col ..... \$ 460  
Okidata Microline 83A with Tractor - 100 Col ..... \$ 685  
Okidata Microline 84PS - 200 cps Par/Ser ..... \$1125  
C. Itoh Prowriter - Parallel ..... \$ 485  
C. Itoh Prowriter - Parallel/Serial ..... \$ 610  
C. Itoh F-10 Starwriter - Parallel - 40 cps ..... \$1395  
C. Itoh F-10 Starwriter - Serial - 40 cps ..... \$1495  
Brother Daisy Wheel Printer - Parallel ..... \$ 855  
Brother Daisy Wheel Printer - Serial ..... \$ 895  
For more printer information circle reader service card # 54

### MONITORS

#### BMC International

\* 12" Green monitor with P-31 phosphor  
\* 15 MHz\* Excellent for 80 column display  
BMC 12" Green Monitor ..... \$ 88  
\* 13" Color Monitor\* Audio and Video  
\* 270 Line resolution  
BMC 13" Color Monitor ..... \$ 273

#### AMDEK Monitors

\* 12" Green Phosphor  
\* Non-Glare  
AMDEK Video 300 ..... Call for Price  
\* 13" Color Monitor\* RGB Input  
\* For IBM/NEC/Apple  
AMDEK Color II ..... Call for Price  
AMDEK Color I ..... Call for Price  
AMDEK Color III ..... Call for Price

### NEC

NEC 12" Green Monitor ..... \$ 159  
NEC 13" Color Monitor ..... \$ 325  
NEC 13" RGB Color Monitor ..... \$ 815

### ZENITH

Zenith 12" Green Monitor ..... \$115

### TeleVideo Products

TeleVideo computer terminals and desktop computer systems-high price features at low prices

#### TeleVideo TS-802 Computer system

\* 64K, 4 Mhz Z-80A, CP/M \* Dual Floppies, 720K Total  
\* Same CRT and Keyboard as TeleVideo 950 Terminal  
\* Network Expansion Capabilities  
TeleVideo TS-802 ..... \$2665  
TeleVideo TS-802H Same as TS-802  
with one floppy and 5-MegaByte Hard Disk ..... \$4990  
TeleVideo TVI-910 Terminal ..... \$ 575  
TeleVideo TVI-925 Terminal ..... \$ 725  
TeleVideo TVI-950 Terminal - TOP-OF-LINE ..... \$ 915

### SOFTWARE

BISON carries software for all business and personal computer systems. Just select the software you want and call us for our current price. Here are some examples of BISON'S Low Prices:

#### MicroPro Software

WordStar - 8" CP/M ..... \$ 250  
WordStar - Apple CP/M ..... \$ 192  
MailMerge - 8" CP/M ..... \$ 77  
MailMerge - Apple CP/M ..... \$ 63  
SpellStar - 8" CP/M ..... \$ 127  
SpellStar - Apple CP/M ..... \$ 105  
DataStar - 8" CP/M ..... \$ 175  
Super Sort - 8" CP/M ..... \$ 127  
Super Sort - Apple CP/M ..... \$ 100  
Super Sort II - 8" CP/M ..... \$ 105  
CalcStar - 8" CP/M ..... \$ 149

### S-100 PRODUCTS

Whatever you need for your S-100 system, from CPU's to Memory, BISON has it. Just look at our list. If you don't see it here, call for our current price

#### Sierra Data Sciences

S-100 Master/Slave Single Board Computers  
Master - 4 Mhz, Z 80A ..... \$ 690  
Slave - 4 Mhz, Z 80A ..... \$ 625  
Sierra Data CP/M ..... \$ 160  
Sierra Data BIOS ..... \$ 100  
Sierra Manual ..... \$ 25  
Sierra Data - Winchester Adaptor ..... \$ 145  
Sierra Data Turbo DOS ..... \$ 750

#### QT-Systems Mainframes

S-100 Mainframe and 8" Drive Enclosures  
\* S-100 Power +8V/25A +16V/5A -16V/5A  
\* Drive Power -5V/2.5A -5V/ 5A -24V/3A  
\* Keypad Power Switch  
\* Shielded Motherboard  
\* Rugged Card Cage  
\* 9" x 17" x 21" (H x W x D)  
QT 6-Slot, Dual 8" Drives ..... \$ 705  
QT 8-Slot, Dual 8" Drives ..... \$ 730  
QT 12-Slot, Dual 8" Drives ..... \$ 755

#### S-100 Mainframe and 5 1/4" Drive Enclosures

\* Similar to 8" Mainframe  
\* 7" x 17" x 20" (H x W x D)  
QT 6-Slot, Dual 5 1/4" Drives ..... \$ 530  
QT 8-Slot, Dual 5 1/4" Drives ..... \$ 555  
QT 12-Slot, Dual 5 1/4" Drives ..... \$ 580

### STATIC MEMORY SYSTEMS 64K RAM

\* 24 Line Addressing  
\* 200 NS Low Power CMOS  
\* Intermix RAM and EPROM  
\* List Price \$594 Static Memory Systems  
64K RAM ..... \$ 440

### AB DIGITAL DESIGN LABS

256K Byte - 126K Byte Words  
\* 4 Mhz with Extended DMA  
\* IEEE-696  
\* Multi-Layer PC Board  
\* 1 Year Warranty  
\* List \$1295  
AB DIGITAL DESIGN LABS 265K RAM ..... \$ 825

### DISK DRIVES

Cume #842 (Replaces Data-Trak 8) ..... \$ 480  
Tandon Thin 8" Single-Side Double-Density ..... \$ 382  
Tandon Double-Density ..... \$ 485

### SUPER BISON SPECIAL

Mitsubishi 8" Double-Density Double-Sided  
Floppy Disk Drive ..... \$ 399  
QUANTITY DISCOUNTS AVAILABLE - CALL BISON  
TRAK Dual 8" Floppy Disk Drive Cabinet  
\* Vertical Mount  
\* Signal Extender Cable  
\* Write Protect Switches on Front  
\* Power Supply, Fan  
\* Highest quality construction  
Trak Dual 8" Floppy Disk Cabinet ..... \$ 325

### SEATTLE COMPUTER 8086 SUPER MICRO

16-bit Micro-computer system  
\* 8 Mhz 8086 CPU  
\* Full s-100 Compatibility  
\* 128K 70 NS Static RAM  
\* MS-DOS (86-DOS)  
\* Double-Density Disk Controller  
\* 22-Slot Mainframe  
\* Just add Drives and Terminal  
\* List Price \$4185  
Seattle Computer 8086 Computer System ..... \$3450  
Seattle Computer 8086 Board Set with DOS ..... \$ 595

### DYSAN Floppy Disks

Dysan 104/15 1/2" Soft Sector  
Box of 10 ..... \$ 35  
Dysan 104/1D 5 1/4" Soft Sector Double Density  
Box of 10 ..... \$ 42  
Dysan 3740/1 8" Soft Sector  
Box of 10 ..... \$ 45  
Dysan 3740/2D 8" Soft-Sector Double-Density  
Box of 10 ..... \$ 63  
For more S-100 information, circle reader service card # 55

# WE DROVE THE COST OF DISK DRIVES WAY DOWN



Apparat continues to expand our line of IBM PC compatible products. Buy a minimum IBM system from any dealer, then look to Apparat to complete and expand it. And save about 25% over a comparable system. You will even find that we've developed some products you can't find from any other manufacturer or distributor.

#### **IBM compatible add-in and expansion drives.**

- Single and Double sided 40 track drives. Both drives (Tandon or CDC available) are fully supported by PC DOS version 1.1, and you can mix or match. Drives are easily installed in minutes. Single sided (160 k) — \$225 each, Double sided (320K) — \$315 each.
- Double sided 80 track (650K) Tandon drive. Easily installed in

minutes. Requires software patch — \$435.

- Expansion cabinet for 3rd and 4th drives. Any of the IBM compatible drives above are easily mounted into the matching case. Power supply and cable included — \$275. With 2 dual 40's internally and 2 in the expansion cabinet you have over 1.2 megabytes of storage on-line and supported by an unmodified PC DOS 1.1.



# SO YOU CAN DRIVE YOUR IBM PC CAPABILITIES WAY UP



## More savings on these add-ons.

- **Combo Card.** Adds parallel printer, RS 232 asynchronous communications and clock calendar functions. Uses only one slot and includes RS 232 cable — \$279.
- **Clock Calendar Card.** Features seconds, minutes, hours, day of week, date, month and year. Battery backup maintains time and date even when system is turned off. Software compatible with PC DOS — \$129.
- **Prototype Card.** 3.5 by 8 inch wirewrap area holds over 85-14 pin dips — \$29.95.
- **64K Byte Hardware Print Spoolers.** Internal spooler comes with parallel printer adapter. External version connects easily between computer and printer. Both

buffer 32 pages of print output and are user programmable — \$399.

- **Add-On Memory Card.** Uses 64K dynamic RAM chips, with parity. All are expandable to 256K. 64K — \$299, 128K — \$399, 192K — \$499, 256K — \$599.
- **Monitors.** High quality, reliable, 12 inch green screen. NEC, 20 MHz BW — \$195, Amdek, 18 MHz BW and anti glare — \$180.
- **Printers.** A variety of the newest Epson, NEC and Okidata printers available. Call for prices.
- **48K Additional Ram.** 27 chips plug easily into master PC board — \$75.
- **RGB Color Monitors.** Includes cable and modification to include 16 colors — intensity control. NEC (resolution 690 by 230) — \$995, Amdek (560 by 240) — \$899.

- **Prom Blaster.** Programs most 4K to 64K bit 24 PIN EPROMS. Complete with personality modules and read/write software — \$149.
- **Apparat Game Diskette.** Includes blackjack, othello, matches and spiralgraph — \$24.95.

Apparat will continue to develop add-on products for your IBM PC. And Apparat warrants and services all the products we sell. Call today to order any of the products listed here or to find out more information write Apparat, Inc., 4401 So. Tamarac Parkway, Denver, CO 80237, (303) 741-1778. Dealer inquiries welcome. To order any product today call

**800/525-7674.**

IBM PC is a trademark of IBM.



**Apparat, Inc.**



# Expand Your IBM P.C.



\$229<sup>00</sup>

## ■ Memory Expansion Board

(PC)<sup>2</sup>'s Expansion Board offers 4 TIMES the amount of memory offered by IBM P.C. Configurations can be set at 64K, 128K, 192K and 256K Bytes. Board can be easily upgraded in 64K capacities. Upgradability is the key!



\$1895<sup>00</sup>  
For  
6M Bytes

## ■ Add-In Winchester Disk System

(PC)<sup>2</sup>'s Add-In Winchester Disk System is housed within the IBM chassis and is easy to install directly into the floppy slot, reducing desktop space. Also available in 12 and 18 M Bytes capacity.

## ■ Asynchronous Communications Controller

1 or 2 line capability on one card.  
Totally compatible with IBM software and diagnostics.

As  
little as  
\$85<sup>00</sup>

## ■ DS-Disk Software

(PC)<sup>2</sup>'s software program doubles the IBM's single-sided diskette capacity by using both sides. Increases capacity from 160K to 320K. Used with Tandon TM100-2 disk drive or equivalent.

\$40<sup>00</sup>

**PHONE OR WRITE — BUT ORDER NOW!**

(PC)<sup>2</sup>, P.O. Box 678  
510 Lawrence Expressway  
Sunnyvale, CA 94086

**(408) 749-9313**

Postage and Handling included within continental U.S.A.  
One year warranty on all board products.  
MasterCard, Visa and Checks accepted.



PLUG COMPATIBLES FOR PERSONAL COMPUTERS

if you don't know Pascal and intend to learn it, I *strongly* advise you to buy the Workman package (compiler, *Programming in Pascal*, *Software Tools in Pascal*, and Alex's lesson disk). That way you won't waste so much time with trivial error hunting, and you can get down to the business of playing with those programs, modifying them, and using the more useful ones.

And if your time is at all valuable, get either M-Drive or Semidisk. The slower your floppy disks, the more dramatic the result, but even with fast disks like Qume DT-8s run by a Compro controller, the time saved adds up fast.

## CB/80 Revisited

There is an alternative: Digital Research's CB/80, which is compiled CBASIC. Our tests so far show that CB/80 is pretty comparable to Pascal/MT+ in speed and compactness of code. It's *reasonably* easy to patch in assembly-language subroutines in CB/80, so that you can optimize loops and other things that you use all the time. There's a new version of CB/80 with an improved linker that's supposed to make patching in subroutines even simpler; I'll have it in a couple of weeks, and I can report on it then.

Despite my mad friend's misgivings about all forms of BASIC, CB/80, in my judgment, remains a real competitor to Pascal and PL/I. It won't write code as fast or as compact as C, but then few higher-level languages will, and it's a lot easier to learn than C. I suspect, in fact, that my mad friend would salve his anti-BASIC prejudice by pronouncing that CB/80 isn't "real" BASIC at all but a separate new language.

He'd have a point, too, since CB/80 has few of the inherent defects of BASIC. With CB/80 you can have truly local variables within functions and procedures and call them either by label or by value—that is, you can hand the procedure the actual value of the variable it is to work with, letting it create a variable that's local to the procedure so that whatever it does cannot change the "real" variable out in the main program; or you



**MULTI-USER HARD DISK  
SYSTEM—\$10,500.**

# Think Now!

Multi-user MP/M™ 8-16\* runs 8 bit CP/M® software better than it's ever been run before.

- **BIG**—over 61K! That's over 6K more user space than conventional CP/M 2.2™!
- **FAST**—DMA floppy and hard disks with cache buffering and high speed CPUs.
- **MULTI-USER**—enhanced and fully compatible implementation of MP/M 86™ runs both 8 and 16 bit programs at the same time! 8 bit programs you can run include: WordStar®, dBASE II™, Whitesmith's C, Microsoft™ BASIC, CB80™ and PL/I-80™.

# Think Ahead!

MP/M 8-16 runs 16 bit CP/M 86™ software, so you can get what's coming!

- Upgrade effortlessly from 8 to 16 bit software (for example, from CBASIC™ to CBASIC 86™) without leaving your programs or data behind. You get complete file compatibility between 8 and 16 bit CP/M. Other systems make you choose between 8 and 16 bits. MP/M 8-16 systems have two CPUs—one 8 bit, one 16 bit. You get it all. Now. And tomorrow.
- 16 bit programs available now include: CBASIC 86, SuperCalc 86™, Microsoft FORTRAN 86 (ANSII 77), CIS COBOL 86™.
- Even the hardware is upgradable. Our boards are compatible with the IEEE 696 bus (and we've got 20 bus slots!). Our state-of-the-art systems can keep pace with the state-of-the-art.
- All CompuPro boards in our MP/M 8-16 systems are covered by a factory backed two year phone replacement warranty.

G&G Engineering is an authorized CompuPro systems center.

# Think **G&G** ENGINEERING!

1922 Republic Avenue, San Leandro, California 94577 (415) 895-0798  
351 California Street, Suite 515, San Francisco, California 94104

\*MP/M 8-16 is a proprietary implementation of Digital Research's MP/M 86 operating system, configured for CompuPro by G&G Engineering.  
CompuPro is a trademark of Godbout Electronics; MP/M 86, CP/M, CP/M 2.2, CBASIC, CBASIC 86, CB-80, PL/I-80, and CIS COBOL 86 are trademarks of Digital Research. Microsoft is a trademark of Microsoft Corporation. WordStar is a registered trademark of MicroPro International Corporation. dBASE II is a trademark of Ashton-Tate. SuperCalc 86 is a trademark of Sorcim.  
Circle 202 on inquiry card.



The facts.  
And nothing but the facts.

Epson.

Our MX Series printers are the best-selling dot matrix printers in the entire world. This is why.

**Fact One: We've got your type.**

Epson invented correspondence quality printing. And we still do it better than anybody.

But more importantly, we do *more* of it than anybody. On every Epson MX printer, you get a choice of *sixty-six* different type styles, including italics, a handy subscript and superscript for scientific notation and small print, enough international symbols to print most Western languages, and one-pass underscore. All in a tack-sharp, easy-to-read 9x9 matrix with full descenders.

If print quality is important to you, your next printer is an Epson.

**Fact Two: Ultra-high resolution graphics.**

There simply is no higher resolution graphics than GRAFTRAX-PLUS. And it comes standard on every MX.

You get bit image graphics free of wander, walk and jitter; graphics with blacker blacks and better definition because you can precisely place a dot at any of 25,920 positions inside a square inch (that's 120 DPI h x 216 DPI v); graphics that make our printers rival plotters.

If graphics is what you want, your next printer is an Epson.

**Fact Three: Feature shock.**

The Epson MX Series is packed with the features printer fanatics want most. A bidirectional print head with logical seeking of the shortest line. Programmable tab, form length and right margin. Top of forms recognition. Skip over perf. Software printer reset. True

backspace. Self test. The world's only disposable print head. And more. Lots more. On our MX-100 and MX-80 F/T, you even get both friction *and* tractor paper feed.

If you want performance, your next printer is an Epson.

**Fact Four: Incredible reliability.**

Epson MX Series printers are the most reliable printers ever made. And the reason is precision.

Take a look inside one and you'll understand. Notice the simplicity, the fit, the finish. That's why Epson has an out-of-box reliability rate others can only envy: 98%. And why our mean cycles between failures (MCBF) is over five million lines.

The whole package is neatly wrapped in a rugged plastic injection-molded case designed to look good — and stay looking good.

If you want a printer that works, and keeps on working, your next printer is an Epson.

**Fact Five: World's best seller. Period.**

Within months after we introduced the Epson MX-80, it was the best selling dot matrix printer in the world. It still is. Not because of anything *we* said, but because tens of thousands of computer enthusiasts went out and did some serious comparison shopping. *They* decided it was the best printer for the money they could buy. And who are we to argue?

If you want the world's best seller, your next printer is an Epson.

**Fact Six: Quality doesn't cost more.**

Don't take our word for it. Check it out. Look at what they give you. Then look at what we give you. Then look at the price.

There is only one logical choice. Epson. And that's the truth.

*"In my judgment,  
this is the  
best printer  
you can buy."*



Your next printer.

**EPSON**  
EPSON AMERICA, INC.  
COMPUTER PRODUCTS DIVISION

3415 Kashiwa Street  
Torrance, California 90505  
(213) 539-9140

# First we made IBM's baby grow up. Now we've made it think faster.

**Only RAM+ from Seattle Computer gives your IBM-PC up to 256K of memory, the versatility of a built-in RS-232 serial port plus the speed of Flash Disk™ software.**

Seattle Computer announces a major programming innovation for the IBM Personal Computer.

Our new RAM+ Flash Disk software lets you use memory like a disk. Flash Disk finds information in a flash by electronically simulating a disk drive 10 to 50 times faster than a mechanical disk. By copying your most-used programs and data to Flash Disk, you make them instantly accessible—ending those long disk access delays. Flash Disk is also ideal for temporary intermediate files.

And best of all, Flash Disk comes free with the RAM+ memory cards. Or, if you already own RAM+, Flash Disk software is available from your dealer.



As always, the beauty of RAM+ is the combination of memory and serial port on a single card. Not only does it save the \$150 an IBM serial card would cost, but it also leaves an open slot for further additions—like another RAM+ card.

Available in 64K, 128K, 192K or 256K, RAM+ is expandable, fast and reliable. Each card comes fully tested and with a one-year guarantee. (Expansion kits are also available.)

Of course it's made by Seattle Computer. We're the people who wrote the operating system of the IBM-PC, and we're still first in innovation.

How to order: New RAM+ with Flash Disk is available through your local computer store. Call us toll-free at **1-800-426-8936** for the location of your nearest RAM+ dealer.

**SEATTLE  
COMPUTER**  
1114 Industry Drive Seattle, Washington 98188

can write the procedure so that it manipulates global variables and affects everything. True, CB/80 doesn't name its multiline functions *procedures*; but they have all the attributes of a Pascal procedure, can be called by name, and in some ways are easier to use.

The bottom line is I'm still thinking about the language problem. I don't think anyone knows which will be—or *should* be—the microcomputer language of the future. But now that CB/80 is available without unduly restrictive licensing agreements, I wouldn't count it out.

### Cardfile

Longtime readers of this column will know that I have no high opinion of the prevailing state of program documentation. There's a reason for that. For example, about a year ago, I received, unsolicited, a program for review. It came with a handsome document and had an intriguing name that made it sound as if it might be very useful. My mad friend Mac Lean claimed it as his next project, and that seemed reasonable, so I let him take it away.

**Once I got  
Cardfile running,  
I liked it fine.**

He returned it the next week. "Does it work?" I asked. "I think so." "You think so?" "Yeah. It seems to work all right. Nifty images come up on the screen, the cursor moves around. . . ."

"Then what's wrong?" I asked. "I have read the document five times, and I cannot understand what the program *does*."

He was right, too. That program now lies under a moldering pile of unreviewed software languishing in a far corner. It may stay there forever.

Which brings us to Cardfile, a rather nifty program distributed by Digital Marketing Corporation, whose rather distinctive logo has appeared in a number of computer

magazines lately. Digital Marketing seems to have sent me Cardfile and Synopsis, or perhaps I picked them up at the West Coast Computer Faire; if there was a cover letter, I've lost it, so I've no way of knowing where I got it, and yes, this is relevant to the review.

However I acquired them, Cardfile and Synopsis reached the top of the queue; and all my students and associates were working on other projects. From the titles they sounded intriguing. Cardfile, for example, is subtitled File Card Index Program,

which sounded useful, and when I got inside, the "Overview" section of the program document informed me that "Cardfile automatically stores, retrieves, and displays information that is typically kept in index card files—summaries of articles and books, notes, recipes, menus, catalogs of books, phonograph records, tapes, etc."

Now that sounds pretty good. Down below it tells me that "Cardfile requires an 8080/8085 or Z80 computer with at least 52K RAM; CP/M 2 or MP/M; and Wordstar, Spell-

# J A D A N U S

Question: **When can I use Ada?**

Answer: **NOW —  
with JANUS.**

**Ada is available now for your micro-computer.**

JANUS is a subset of Ada which includes those features sorely missed by programmers on micros. Here is a list to help you decide for yourself.

- + Modular Separate Compilation
- + Single and Double Precision Floating Point Numbers
- + Binary Coded Decimal (BCD) Fixed Point Numbers
- + Integer and Long Integer Numbers
- + Complete String Handling
- + Sequential and Random Access I/O
- + Full Dynamic Allocation and Deallocation
- + Friendly Error Handling
- + An Assembler for interfacing assembly routines
- + A Linker for combining modules
- + True native code is produced
- + ROMable, reentrant code
- + Run-time library source code
- + Low Cost. JANUS is more cost effective than any other comparable Ada package
- + Inexpensive Updates
- + No royalties for programs written in JANUS
- + No hassle customer service

*The language  
that is based  
on the past  
but looks to  
the uses of  
the future.*

In short, all pluses. JANUS contains everything you need to do fast, structured program development in a micro environment.

JANUS is available for the CP/M, CP/M-86, and MS-DOS operating systems.

**Now you too can take a step forward into the future on these computers:**

8080/Z80 based systems: (All CP/M) Apple Softcard, North Star, Cromemco, Superbrain, TRS-80 Model II, and all CP/M 8" disk systems.

8086 based systems: IBM Personal Computer, Victor 9000, Seattle Computer System II, Tecmar, Lomas Data Products, and all CP/M 8" disk systems.

8080 or Z80, CP/M (requires 56K memory) — \$300.00

8086/8088, CP/M-86 or MS-DOS (requires 96K memory) — \$400.00

CP/M, CP/M-86, MP/M-85 are trademarks of Digital Research, Inc.  
\* ADA is a trademark of the U.S. Department of Defense  
MS-DOS is a trademark of Microsoft

86-DOS is a trademark of Seattle Computer Products  
88-86 is a trademark of Lifelab Associates  
Apple Softcard is a trademark of Microsoft, Inc.  
©Copyright 1982 RR Software

**RR SOFTWARE**

*specialists in state of the art programming*

P.O. BOX 1512 MADISON, WISCONSIN 53701

(608) 244-6436

# All that personal were a few profes

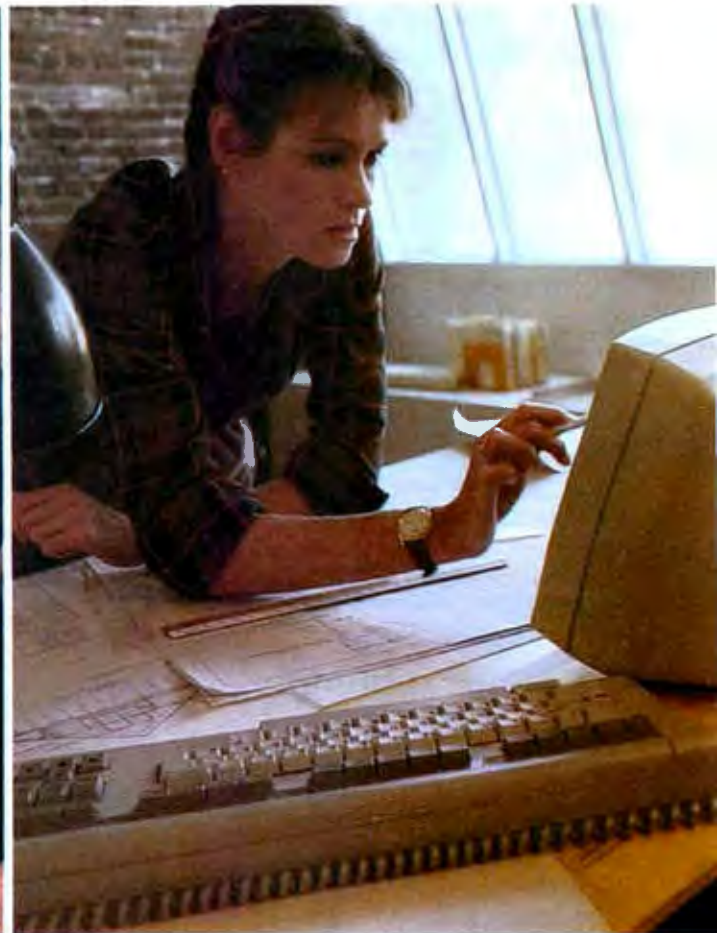
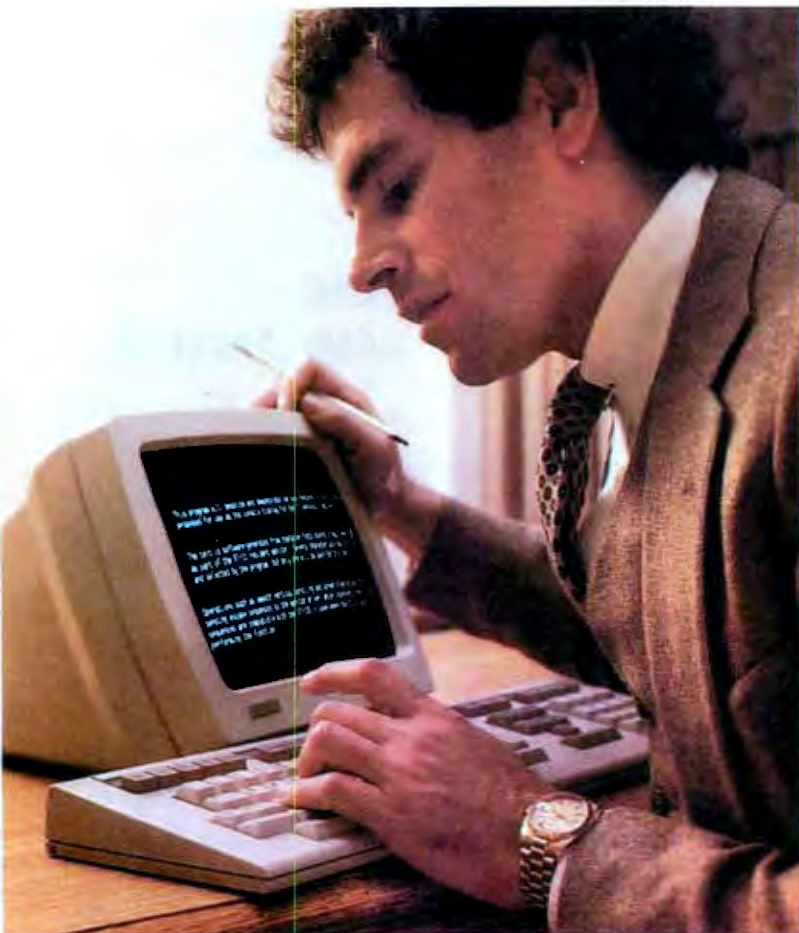

Until now, manufacturers have made personal computers that were a hopeful compromise between home use and business.

But now Digital Equipment Corporation offers the first personal computers designed—and built—strictly for professional use. And since different professionals have different needs, Digital is introducing not one, but three personal computers made to professional standards.

From keyboards to CRTs to software, all three computers are designed to be easy to learn, use, and maintain. They all have the communications capability to get you into larger

systems and networks. And they're all backed by the service, support, and quality that have made Digital the second largest computer company in the world.

**Digital's Professional 300 Series** is a full-blown PDP-11 minicomputer for your desk. It includes P/OS, a multi-tasking operating system; an optional 5 mb Winchester disk; and bit-map graphics, including color. With comprehensive communication facilities, the Professionals can handle text, data, pictures, even voices on the telephone, linking them with other personal computers or larger systems, such as Digital's VAX. And a standard user interface lets you run



# computers needed professional standards.



all applications with the same basic menus, prompts, and help commands.

**Digital's DECmate II** is the first personal computer that can manage an office. It runs a complete array of business and accounting applications, fully supported by Digital. Plus professional-quality word processing, list processing and office management software. It can even run conventional CP/M® programs.

**Digital's Rainbow 100** is for the professional who wants to use the wide range of available 8- and 16-bit CP/M personal computer software. For the price of an ordinary personal computer, you get a CRT that's a full 132 charac-

ters wide; optional bit-map graphics, including color; and professional-level communications.

For more of the story, call 1-800-DIGITAL.

For personal computers that are as professional as you.

More personal.  
More computer.

digital

# CALL "THE-COMPUTER-LINE"<sup>TM</sup> FOR ALL YOUR IBM<sup>®</sup> PERSONAL COMPUTER REQUIREMENTS

## QUADRAM CORPORATION

### QUADBOARD

The ultimate memory board for the IBM, featuring:

- fully expandable from 64 to 256K
- parallel port
- asynchronous (RS232) serial port
- clock/calendar

### \$CALL

### MICROFAZER

- buffering from 8 to 64K (4 to 32 pages of text)
- printer and computer independent
- parallel/parallel; serial/serial and parallel/serial available
- compute while you print!

### \$CALL

### INTERFAZER

Used as:

- Peripheral buffer
- Multi-User Printer Controller
- Computer I/O Expander
- Incompatible Device Interface
- Peripheral Multiplexer
- Data Transfer Rate Converter

### \$CALL

NEC		INTEGRAL DATA SYSTEMS	
NEC 8023A	\$ 489	PRISM 132 COLOR PRINTER	
NEC 7710	\$2339	INCLUDING ALL OPTIONS	
		• 4-COLOR PRINTING	\$1595
		• FRICTION FEED	
		• 200 CPS SPRINT MODE	
EPSON		C-ITOH	
EPSON MX80III	\$ 429	F10 Word Quality Printer	
EPSON MX80FT III	\$ 529	• 40 CPS Printing	
EPSON MX100 III	\$ 699	• Letter quality excellence	
ALL EPSON AND NEC		Now Only \$1395	
DOT MATRIX PRINTER		Prowriter 120cps \$469.00	
PRICES INCLUDE SHIPPING AND INSURANCE FOR IMMEDIATE DELIVERY.			

OLIVETTI  
LETTER QUALITY PRINTING \$1445

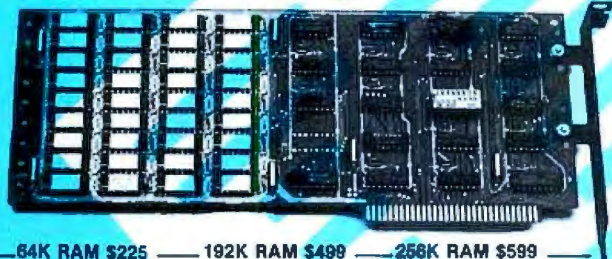

— 64K RAM \$225 — 192K RAM \$499 — 256K RAM \$599 —

### TANDON ADD-ON DRIVES FOR IBM

TMS-100-1	\$225	TMS-100-2	\$285
Single sided		Double sided	

### DISKETTES

SCOTCH WITH PLASTIC LIBRARY CASES (Boxes of 10)	
(48 Track single-sided double density)	\$26-50
VERBATIM DATALIFE SS/DD (Boxes of 10)	\$24-95

### IBM SOFTWARE

BUSINESS		ENTERTAINMENT	
WORDSTAR	\$289	GALACTIC ATTACK	\$28
MAILMERGE	\$ 79	ZORK I	\$29
TAX MANAGER	\$199	ZORK II	\$29
256K VISICALC	\$189	DEADLINE	\$39
VISITREND/VISIPLOT	\$239	**CALL FOR NEW	
VISIDEX	\$189	GAMES AT	
EASY EFFECTIVE ACCOUNTING		UNBEATABLE PRICES**	
SYSTEM	\$389		
SUPERCALC	\$219	T and G JOYSTICKS	\$44.95
SUPERWRITER	\$289	ADAM AND EVE	
		PADDLES	\$28.95
CALL FOR SOFTWARE NOT LISTED			

## Davong Systems, Inc.

### Description:

The Davong Systems Memory Card is a convenient RAM memory expansion card for use in the IBM Personal Computer.

The Memory Card may be placed in any free system slot. It is completely compatible with all IBM Personal Computer software and hardware, and runs at the same speed as IBM memory products.

### Features:

- 64K IC's provide low power consumption and maximum reliability.
- Extended burn-in at elevated temperature.
- Switch-selectable address range.
- Filtered voltage provides low noise.
- Power consumption:

DSI-192K	+ 5 v. @ 850 ma—max.	DSI-192K	+ 5 v. @ 560 ma—typ.
DSI-64K	+ 5 v. @ 650 ma—max.	DSI-256K	+ 5 v. @ 900 ma—max.
	+ 5 v. @ 410 ma—typ.		+ 5 v. @ 580 ma—typ.

## Hard Disk System for the IBM<sup>®</sup> Personal Computer.

**ONLY \$1595.00**

### Description:

The Davong System's Hard Disk Drive fits conveniently inside the second floppy drive location of the IBM Personal Computer chassis, providing more than 30 times the capacity of a floppy diskette, plus greater speed and reliability.

The DSI-501 System is compatible with IBM software, and supports IBM DOS<sup>®</sup>. The system includes all necessary components and software for installation.

### Features:

- 6.4 Mbytes unformatted; 5 Mbytes formatted.
- Winchester technology 5 1/4" disk drive.
- Compatible with IBM software.
- Full software support includes:
  - Installation/configuration program
  - Complete diagnostics
  - Hard disk formatter
- Complete with all components required for installation, including:
  - Disk controller board
  - Power supply
  - Cabling
  - Software to install under IBM DOS disk operating software

12 MEGABYTES STORAGE \$2195.00

### TECMAR PRODUCTS

EXPANSION CHASSIS	PRICE
TIME MASTER	\$ 89
DEVICE MASTER	\$ 189
SPEECH MASTER	\$ 329
SCRIBE TENDER (Two Serial Ports and One Parallel Port)	\$ 159
SCRIBE MASTER (Three Serial and Three Parallel Ports)	\$ 229
LAB TENDER	\$ 329
LAB MASTER	\$ 829
DIGITAL TO ANALOG CONVERTER	\$ 329
VIDEO DIGITIZER	\$ 289

FOR A COMPLETE EXPLANATION OF ALL TECMAR PRODUCTS  
CALL FOR OUR COMPREHENSIVE CATALOG.

### MONITORS

TECO GREEN	\$179	AMDEK COLOR	\$749
TECO COLOR	\$588		

CALL OR WRITE FOR OUR IBM CATALOG  
IN COLORADO (303) 279-2727

CALL "THE COMPUTER-LINE"<sup>TM</sup>  
**1-(800)-525-7877**

COMPUTERWORLD INTERNATIONAL, INC.

SUITE 133, P.O. BOX 81, WHEAT RIDGE, COLORADO, U.S.A. 80034-0081



Circle 121 on inquiry card.

TERMS: RETAIL/MAIL ORDER: ADD 1% SHIPPING (MINIMUM \$2.50) - UPS GROUND.

WE HONOR ALL MANUFACTURERS WARRANTIES AND EXCHANGE FAULTY GOODS IMMEDIATELY.  
SPECIALISTS IN APO AND INTERNATIONAL DELIVERIES.

RETAIL: 1019 8TH STREET  
GOLDEN, CO 80401

## Items Reviewed

<b>Cardfile</b> (by Protem Software)		\$89
<b>Synopsis</b> (by Protem Software)		\$125
Digital Marketing Corporation 2670 Cherry Lane Walnut Creek, CA 94596 (415) 938-2880		
<b>CB/80</b> (compiler version of CBASIC)		\$500
Digital Research Box 579 Pacific Grove, CA 93950 (408) 649-3896		
<b>M-Drive</b>	128K	\$1590
Compupro Systems	256K	\$3100
Oakland Airport, CA 94614-0355 (415) 562-0636		
<b>Pascal Introduction Package</b>		\$50
Workman and Associates 112 Marion Avenue Pasadena, CA 91106 (213) 796-4401		
<b>Pascal/M</b>		\$395
<b>Pascal/M-86</b>		\$495
Sorcim Corporation 405 Aldo Ave. Santa Clara, CA 95050 (408) 727-7634		
<b>Pascal/MT+</b>	8080, 8085, Z80	\$350
Digital Research	8086/8088	\$600
Box 579 Pacific Grove, CA 93950 (408) 649-3896		
<b>Semidisk</b>	512K bytes	\$1995
Semidisk Systems	1 megabyte	\$2995
POB GG	manual only	\$10
Beaverton, OR 97075 (503) 642-3100		

## Books Reviewed

<b>Programming in Pascal</b>		\$15.95
by Peter Grogono Reading, MA: Addison-Wesley Publishing Company, 1980 (rev. ed.)		
<b>Software Tools in Pascal</b>		\$15.95
by Brian W. Kernighan and P. J. Plauger Reading, MA: Addison-Wesley Publishing Company, 1981 (617) 944-3700		

## TRANSITION... ...SOFTWARE

Mainframe...to Mini...to Micro

**COST goes down, while  
utility goes UP**

Innovative memory management software allows programs once reserved for large machines to run on your CP/M 56K to 64K system. All offer GRAPHIC displays with extensive pictorial representation of your data on a variety of graphic devices including CRTs, dot matrix printers, word processing printers, and pen plotters.

(PARTIAL LIST)

### SCIENTIFIC and ENGINEERING

PROJECT EVALUATION (similar to DELPHI)	\$90*
LINEAR REGRESSION	\$90*
3-D GRAPHICS (user functions, enhancement, hidden line)	\$90**
ENGINEERING FIGURE GENERATION	\$90**
BASIC STATISTICS	\$90*
CURVE FITTING (2 variables) (with smoothing, enhancement)	\$90*
NETWORKING (C.P.M., out-of-kilter, etc.)	\$109*

### OTHER CATEGORIES

STOCKS—INVESTMENT MODELING	\$135*
WIRE LIST, PCB LAYOUT, with schematic generation, error list	\$155*
DIGITIZING SUPPORT PACKAGE (includes GRAPHIC EDITING)	\$155**
BUSINESS and DATA ENTRY FORMS DESIGN	\$75**
DRAFTING SUBROUTINE SUPPORT ("rel files," MICROSOFT format)	\$50**
CONTOURING PACKAGE (with gridding, Krigging, enhancement)	\$190**

\*GRAPHICS OUTPUT DEVICE WILL ENHANCE PACKAGE  
\*\*GRAPHICS OUTPUT DEVICE REQUIRED

ORDER BY TITLE, INCLUDE \$6 SHIPPING PER PACKAGE. WE ACCEPT CASH, CHECK, MC, VISA, C.O.D., APPROVED P.O., U.S. FUNDS ONLY. 5 DAY RETURN PRIVILEGE—subject to conditions included in each package. Include diskette type in each order:

8 in. SSSD CP/M  
5 1/4 in. NORTHSTAR  
5 1/4 in. OTHER (Inquire)

FULL BROCHURE AVAILABLE ON EACH PACKAGE—CALL US

## THE ENERCOMP COMPANY

P.O. BOX 28014  
LAKEWOOD, COLORADO 80228  
(303) 988-1648

CP/M—TM OF DIGITAL RESEARCH CORP

binder, Magic Wand, or a similar text editor." Well, I've got an 8085, CP/M 2, and plenty of RAM. I don't have Spellbinder (I've asked, but Lexisoft has never sent a review copy).

I don't have Magic Wand, and therein hangs a tale: when Magic Wand was first developed, the then owners sent me a copy, which I spent far too much time working over. There were about 20 exchanges of letters and a lot of phone calls as I pointed out problems with the editor, especially the disk operations. In general, I ended up putting a lot more time into it than I should have. I did that because I liked the product a lot and thought it ought to have the bugs ironed out.

SBA (Small Business Associates) lost control of Magic Wand. The new owners inherited a pile of correspondence from me. When I called one day to ask what was happening, they acknowledged my help in pointing out design flaws and promised me the new and revised copy of Magic Wand "real soon now." Before I got it, Magic Wand was sold to Peachtree. I've written Peachtree four letters and spoken to its representatives at three different computer shows; the company has yet to acknowledge my existence. Now I have a perfectly good editor, and I don't need Magic Wand, but I do confess some curiosity as to how many of my suggestions the company adopted.

Anyway, I don't have Magic Wand. I do have Wordstar, but I don't use it all that much, and in fact, it isn't on the system master for the

Compupro 8085/8088. But what the heck, WRITE, the editor I use, has some similarities to Magic Wand in that it marks the ends of lines with nothing and the ends of paragraphs with a carriage return but no linefeed; and the document did say "similar" text editor. Maybe it would work.

But then I began reading the rest of the Cardfile document, and holy catfish! It doesn't tell what it does! There's a set of instructions on how to use it, but they weren't helpful—at least not to me—on what the darned program was going to do.

What it said was that after I did some installation, I should use my text editor in a special way to "create a separate document file for each record you wish to enter in the Cardfile index." I could, it said, name the document file anything I want, except that I couldn't use an extension of .Y because the program was going to create another file with .Y extension for each one of the files I was about to make.

This sounded like a great way to fill up a disk but about as useful as a chocolate-covered wristwatch.

Furthermore, the instructions told me that "the disk directory for a standard floppy disk holds 64 entries." That's not strictly true for CP/M 2.2, but it did seem to impose some new limits. What good is a card file that, with its index and command programs, can't have more than 25 or so cards in it? Especially since Digital Marketing Corporation's licensing agreement says I'm permitted only two backup copies of the program.

Well, maybe I was reading it all wrong. I certainly seemed to be having trouble understanding the program instructions (and it wasn't that late, either). So to be fair, I ran the program itself.

I began with the installation routine. It comes up with a menu of Wordstar, Spellbinder, or Magic Wand and will not accept any other editor whatever. So much for "similar," but the heck with it. I told it my editor is Magic Wand, then answered the other questions. What you do is give it the name you invoke your editor with (WS, MW, Foo, whatever; in my case, WRITE) and the name you propose to use to make Filecards (WRITEC in my case). Then you go WRITEC, and up comes their prompt first, then WRITE's.

WRITE seemed to be working all right, barring the fact that I couldn't get the disk directory; apparently, Cardfile's shell program, which the company calls an "environment," interferes with WRITE's rather sophisticated directory calls (which show file size as well as name). Ah, well. Everything else looked all right. So I proceeded to create some typical cardfile "gubbage," saving each file under a different name but with file extension .GUB, and exited the editor. Sure enough, for each of the .GUB files I'd created, there was a corresponding .Y file.

Then I invoked the Cardfile program itself; lo, it worked fine. First it updated its index, then displayed self-explanatory prompts inviting me to search the card-file index. Simply give

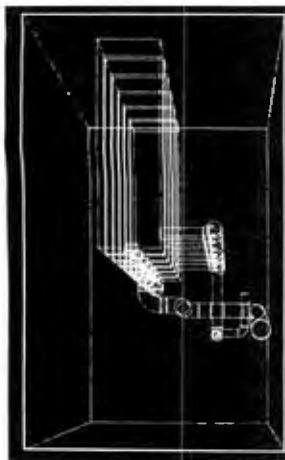

## GRAPHIC SOFTWARE

**GRAPHIC SOFTWARE FOR MICROCOMPUTERS** — This self-teaching guide will show you how to write your own graphics software. 61 programs for 2D and 3D graphics: interactive input, translations, rotation, isometric views, perspective, scaling, stretching, clipping, surface intersections, shading, hidden line removal, tablet software, animation and more. Applications to science, engineering and business. "One of the most outstanding books on computer software" — A. Grund, U. Illinois; "The best book available on microcomputer graphics" — Creative Computing Feb, 1982. Book — \$21.95, Disk — \$18.95.

Books contain fully documented program listings in BASIC with theory and equations. Disks contain the same programs as the books but without documentation. When ordering disks, please specify APPLE II Plus 48K DOS 3.3 or IBM.

## ENGINEERING SOFTWARE

**ENGINEERING SOFTWARE FOR MICROS** — A self-teaching guide to developing software for engineering applications of microcomputers. Emphasis is on combining graphics with engineering problem solving. Programs included to interactively create engineering drawings, store on disk file, recall, modify and merge. Other programs for simulation, mechanisms design, heat transfer, circuit analysis, optimizations and including Monte Carlo techniques. Programs for Fourier analysis display frequency spectra graphically. This is a valuable collection of modern engineering analysis software for students and professionals. Book — \$28.50, Disk — \$19.95.

it a key, and it looks until it finds what you need, which it does pretty fast. And when I exited Cardfile, I found all the .Y files had vanished.

Did I need the original .GUB files? One way to find out was to erase them. And, indeed, the information in them was still available. I'd been fooled by the program document's constant references to "updating the index," which implied to me that it only made indexes rather than copying the entire card-file information. Finally, a careful reading of the document told me what I'd missed: Cardfile creates a random-access file whose default name is CF.DAT. All your information is stored in there. CF.DAT need not be on the same disk as the Cardfile program and, indeed, can be renamed anything you like.

Moreover, all of that is stated in the document, and on reading it over now it's all pretty clear; how could I have missed it?

Well, first, prominently up at the top of page 2, the document describes CF.DAT simply as "a sample data file to permit experimenting with CF." This was apparently sufficient to cause me to ignore any further references to CF.DAT; there were only a couple in the opening sections.

Second, after reading the "Overview," I turned to the "Theory of Operation" section. The section is *not* a description of the program at all; it's a description of how the program does a rather small part of what it does. There is no mention of CF.DAT or even of random-access files. By using the rather pretentious "Theory of

Operation" as a section title while describing only a small part of the program, the documentation writers made it pretty tough to infer what the program really does.

But once I got Cardfile running, I liked it fine. You can use it about as you'd expect, to make notes and the like. You can print the notes on paper, pull them out into separate disk files (so that they can be read into a document), or simply erase them. It's a bit of a pain to exit your editor and then reenter it when you want to make a note for another time, but the document tells you how to avoid doing that (as a matter of fact, in the infamous "Theory of Operation" section).

I presume that Synopsis works much the same way; a cursory look at the system documentation drove me away, but that was before I mastered Cardfile. Now that I understand what the program does and sort of how it does it, the Synopsis document no longer looks so forbidding. What Synopsis does is let you put four lines at the top of any document you like, then read those four lines into a random-access file called SYN.DAT. It keeps keys to those lines in SYN.KEY and has various search modes. Of course you ought to make the four lines as descriptive as possible.

Synopsis will automatically make the first four lines of a file *comment lines* for your editor (so long as that editor is Wordstar, Spellbinder, or Magic Wand). A comment line is one that will show on the screen but will not be printed. Wordstar uses "." to

introduce a comment line. Spellbinder uses ".r", while Magic Wand uses "\\*". As an aside, I've often wondered why text editors can't use something sensible, like

```
∴ (* - { /*
```

or preferably *all* of them, as comment line markers. As you may have noticed, the characters ;, (\*, -, /\*, and { are the "open comment" characters for the 8080 assembler, Pascal, Ada, Pascal again, and C compilers, respectively, and thus will be ignored during assembly or compilation. By allowing the "open comment" character followed immediately by a "." to be the *editor's* comment line marker, you could embed formatting and comment commands into your programs and still compile directly rather than recopy. I've mentioned this to Tony Pietsch, and he's modifying WRITE to work that way.

In addition to the four-line synopses, Synopsis also catalogs the filename and disk name. (You name the disk with a title beginning with a hyphen so that it will be sorted to the top of the file.)

Anyway, I haven't run Synopsis, but I can see how it could be useful, and since it works pretty much the way Cardfile does, I don't foresee any difficulties with it. It seems to have some similarities to the Ward Christenson Catalog program (public domain) available from Barry Workman or the CP/M User's Group, but it has added features as well. I expect we'll be using Cardfile here. ■

## STRUCTURAL ANALYSIS SOFTWARE

**STRUCTURAL ANALYSIS ON MICROS** — This self-teaching guide contains a series of programs which calculate stresses and deflections in beams, plates, trusses and frames using conventional and matrix techniques. Theory, equations and program listings fully documented. Written for the non-specialist who wants to use his micro for structural analysis with minimum investment in time. Use the programs as is or modify for your own applications. Book - \$39.95; Disk - \$19.95.

## DATA PLOTTING SOFTWARE

**DATA PLOTTING ON MICROS** — A collection of programs to process and display all types of data: bar charts, stock market charts, engineering and scientific data, 3D views of surfaces, pie charts, sorting, filtering, running averages, curve fitting, and more. Application to business, engineering and science. All programs fully documented and keyed to theory. Use as is or modify for your own applications. Book - \$24.95; Disk - \$19.95.



**KERN PUBLICATIONS**

190 Duck Hill Rd  
Duxbury, MA 02332

To order, send check drawn on U.S. bank, money order in US funds, Visa or Mastercard number with expiration date to KERN PUBLICATIONS 190 Duck Hill Road, P. O. 1029A, Duxbury, MA 02332. Add \$2 per book 4th cl postage in US and Canada, \$3 1st cl or UPS in US, \$4.50 1st cl Canada; \$12 air Europe and Central America; \$18 elsewhere. Call (617) 934-0445 for faster delivery.

# Logo: An Approach to Educating Disabled Children

*Action-oriented learning has dramatic benefits.*

---

Sylvia Weir, Susan Jo Russell  
and José A. Valente  
MIT Logo Group  
545 Technology Square  
Cambridge, MA 02139

---

While a computer is a learning and teaching tool appropriate to many educational settings, it can be much more than that for an educationally disabled child. It makes equal opportunities possible in cases for which conventional educational methods are not feasible or effective. A computer can provide a vehicle for genuine intellectual achievement. For a physically disabled child who has limited access to the world of motion and spatial relationships, for a learning-disabled child who shows a flair for geometric problem solving, and for a nonverbal child who is blocked in establishing communica-

tion, developing a facility in using a computer can be regarded as an essential educational experience.

A major potential of the computer in an educational context is its flexibility, which allows a teacher to tailor a learning situation to the

---

**Logo activity emphasizes methods of doing things rather than answers—process not product.**

---

specific requirements of a particular child. Nowhere is this more important than with disabled children, where the range of individual variation is very great. Such students present the same challenges to teachers as do nondisabled children and, in addition, have many special problems of their own.

The Logo system, pioneered by Seymour Papert at the Massachusetts Institute of Technology and described in his book *Mindstorms* (reference 5), is a computer-based learning environment that is particularly well suited to the kinds of individual tailoring needed by students with special difficulties. From the start, it was Papert's intention that Logo activity would involve more than learning to program. The Logo language contains a set of powerful graphics primitives, a text editor, and full list-processing capabilities. It is a good way to become familiar with programming quickly and relatively painlessly—an important issue for both teachers and children. But more than that, Logo can be extended with user-defined procedures. This extensibility allows a teacher to use programming as a way into other subject areas. By a judicious selection of system-provided and user-defined primitives, the teacher and student

---

#### Acknowledgment

The work described in this article was carried out with support from the Department of Education (#G007802095 and #G008101272) and the National Science Foundation (#SP1 8104890), the Mattel Foundation, and the Hyams Trust.

---

# BYTE Books Carry Waite

## A New Primer Series

### Apple Backpack

Humanized Programming in BASIC

By Scot Kamins and Mitchell Waite



### 8086/8088

16-Bit Microprocessor Primer

By Christopher L. Morgan and Mitchell Waite

Featuring Intel's 8088 as used in the IBM Personal Computer

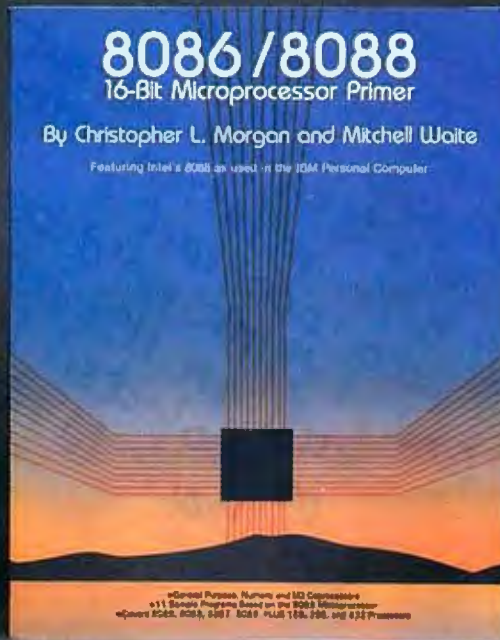

### Word Processing Primer

By Mitchell Waite and Julie Arca

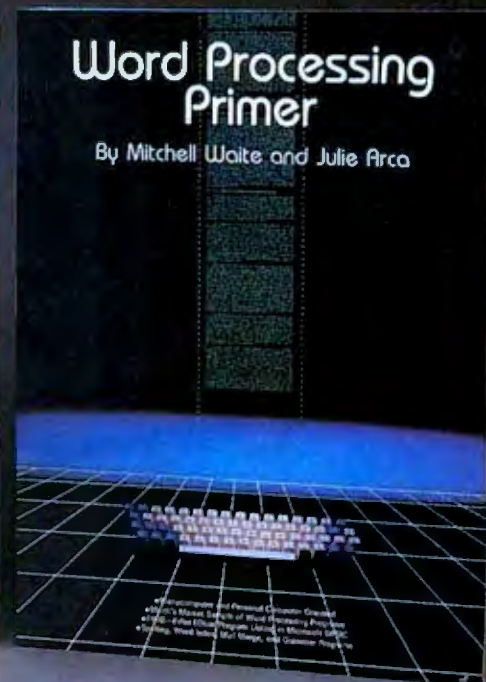

### Apple Backpack

By Scot Kamins  
and Mitchell Waite

If you're a computer user tired of software that assumes an understanding of programming and hardware design, or a programmer interested in writing more effective and easier-to-use programs, then you'll appreciate this presentation of concrete methods for developing "user-friendly" software. Scot Kamins and Mitchell Waite show you how to humanize those once-intimidating screens and keyboards.

In a readable and engaging style, the authors give you complete details on such topics as screen formatting, crashproofing programs, developing built-in verifications and validations, presenting directions on the video display screen, and writing helpful, clear documentation. Full listings of programs in the popular Applesoft BASIC language complement the authors' witty and sensitive solution to one of the major problems preventing microcomputers from reaching their full potential in home or office.

Every computer user and programmer owes a debt to Kamins and Waite for this thorough course in humanized programming.

ISBN 0-07-033356-4 \$14.95

prepayment required  
plus \$1.00 postage and handling fee per book

### 8086/8088 16-bit Microprocessor Primer

By Christopher L. Morgan  
and Mitchell Waite

The new, vastly more powerful 16-bit microprocessors, representing the latest magic in solid-state integrated circuits, are destined to replace today's 8-bit processors in the microcomputers of the 1980s.

You don't have to be a hardware engineer to follow the authors' clear, down-to-earth descriptions of the design, capabilities, and potential of the Intel 8086/8088 16-bit microprocessors. The authors also introduce you to two major 16-bit "coprocessors," the 8087 Numeric Data Processor and the 8089 I/O Processor, and present 11 sample CP/M programs displaying the power of 16-bit microcomputing.

Finally, the authors survey the current scene in terms of available software (like cross-assemblers, 8080 emulators, and operating systems for the 8086/8088) and new products such as the IBM Personal Computer, which is based on the 8088. With its thoughtful presentation aided by numerous illustrations, *8086/8088 16-bit Microprocessor Primer* will put you on the cutting edge of current microcomputer technology.

ISBN 0-07-043109-4 \$16.95

Call Toll-Free 800/258-5420

BYTE/MCGRAW-HILL

### Word Processing Primer

By Mitchell Waite and Julie Arca

The first book to focus primarily on the inexpensive microcomputer-based text-editing products, *Word Processing Primer* gives you a thorough rundown on this new and powerful way to electronically generate, correct, and manage all kinds of typewritten documents.

The authors begin with an overview of the word-processing field, detailing potential applications, suggesting ways to get started, and describing word-processing equipment and programs. A later section on text formatting shows you how to control the appearance of your final printed copy, while another describes programs that will check for spelling errors, create indexes, and generate personalized form letters.

Selecting a word-processing system is made easy as the authors describe the seven most important features to look for. Also, a mini-catalog of available products compares capabilities, features, limitations, and prices.

All of these features, enhanced by many illustrations, make this the most valuable, informative, and up-to-date word-processing guide available today.

ISBN 0-07-067761-1 \$14.95

Circle 67 on inquiry card.

B9



Available Summer 1982  
at your local book or computer store

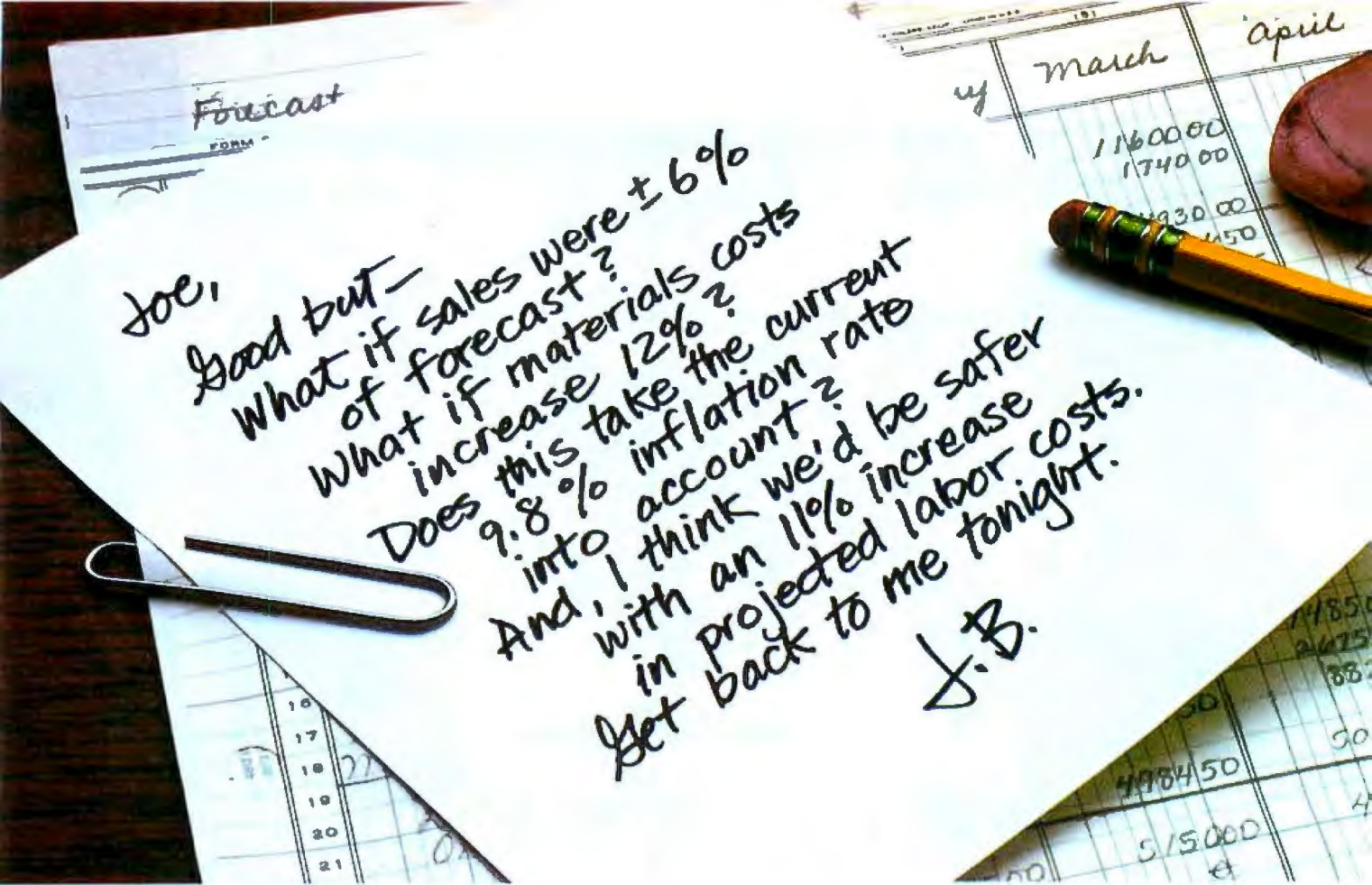

# Now, Microsoft MULTIPLAN. toughest questions

**Better tools.** If you're answering "What if..." questions with a pencil, eraser, calculator and endless manhours, Multiplan gives you a better set of tools.

**Fast answers.** Multiplan is a software program that turns a microcomputer into an answer machine. Multiplan starts as an open "worksheet" of rows and columns. Each intersection of row and column, or "cell," in the worksheet will accept titles, names, numbers or formulas. As you assign names or values to cells, you build a worksheet for a particular problem or set of problems. You establish the logic. Multiplan assigns the time-consuming calculations to the computer. Which means you get answers. Fast.

### Simpler, faster, more powerful.

Multiplan is a completely interactive electronic worksheet. Change one number or formula, and you change every number that

depends on it. Instantly. Furthermore, Multiplan is several worksheets deep. You can pass information from sheet to sheet automatically. A change on your cash and receivables sheet is reflected on your balance sheet, for instance.

### Computing for non-computer people.

You can use Multiplan on a reasonably priced personal computer... even if you've never used a computer before. Plain English "prompts" direct you through each step. If you need additional help, just press the "?" key. Information that addresses your specific question will appear on the screen. Get your answer and return to the problem. Without leafing through a manual.



**Logical problem solving.** Multiplan allows you to assign English names to represent one or more cells on the worksheet. That way, you can refer to items the way you think of them. Profit equals "Sales minus Expenses" for instance. Instead of "L14 minus M17."

**Watch what's happening.** The computer screen displays a portion of a giant worksheet that's 63 columns wide by 255 rows deep. In addition, you can open multiple "windows" to other areas of the worksheet. That capability allows you

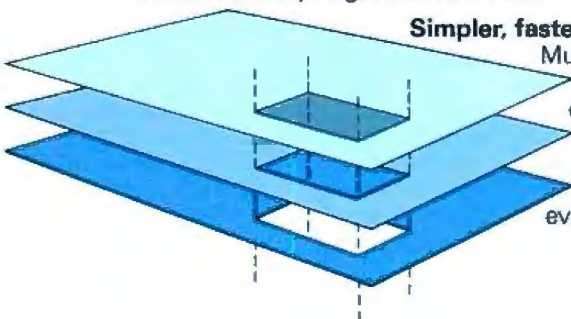



# Subscribe to

the small systems journal  
that keeps you on-line.

# BYTE

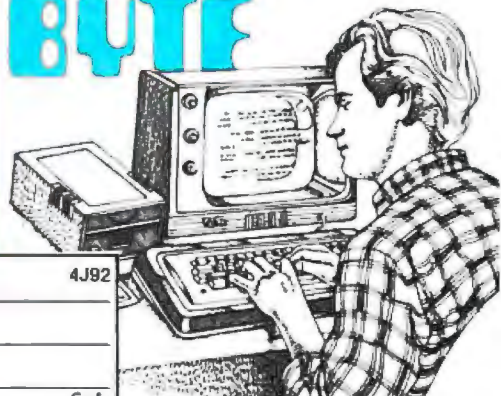

Please print

4J92

Name

Address

City

State/Province/Country

Code

### United States

One year \$19 (12 issues)     Two years \$34     Three years \$49

### Canada or Mexico

One year \$21 (12 issues)     Two years \$38     Three years \$55

### Foreign Rates (to expedite service, please remit in U.S. funds drawn on a U.S. bank)

Europe, one year, air delivered, \$43.

All other countries, one year, surface delivered, \$35

(Air delivery available upon request)

Check enclosed (entitles me to 13 issues for price of 12, North America only)

Bill VISA     Bill Master Charge     Bill me (North America only)

Card Number

Expires

Signature

Allow 6 to 8 weeks for processing your subscription

Every issue of BYTE is filled with stimulating, timely articles on computer hardware, software, applications and reviews of computer products. There is also tutorial information for both the beginner and experienced computer user.

Read your first copy of BYTE, The Small Systems Journal. If it is everything you expected, honor our invoice. If it isn't, just write "cancel" on the invoice and mail it back. You won't be billed, and the first issue is yours at no charge.

©BYTE Publications, Inc. 1981





NO POSTAGE  
NECESSARY  
IF MAILED  
IN THE  
UNITED STATES

**BUSINESS REPLY CARD**

FIRST CLASS PERMIT NO. 39 MARTINSVILLE, NJ

POSTAGE WILL BE PAID BY ADDRESSEE

**BYTE**

**Subscription Dept.**

**P.O. Box 590**

**Martinsville, NJ 08836**

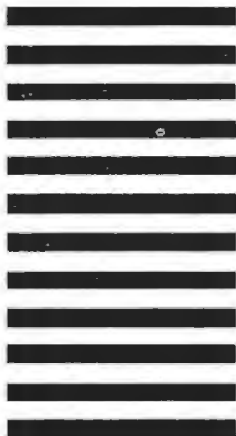



# Fast answers to some of the in business.

to watch what the effect of changing a number or formula in one area will be on other areas of the worksheet. How a change in sales will effect the bottom line, for instance. It's a particularly valuable feature when you're solving "What if..." problems.

**When time is money.** For managers and professionals, time is the most valuable asset. Thinking time. That's the concept behind Multiplan. By assigning the time-consuming aspects of planning, forecasting, interpreting, recording and reworking data to the computer, Multiplan gives you time to think. Result: Not only faster answers... better answers.

**Apple II<sup>®</sup> or CP/M-80<sup>®</sup>** Multiplan is available for the Apple II Personal Computer (in 40 and 80 column versions), and microcomputers utilizing the CP/M-80 operating system.

**Leading edge software.** Claiming quality is one thing. Delivering quality is another. Microsoft has been at the

leading edge of microcomputer software since we put BASIC on the first microcomputer. Today, Microsoft offers an extensive range of fully-supported microcomputer languages, operating systems and applications software. Software like Multiplan... easy-to-use, yet powerful software that makes computers become tools for people.

**Ask for a demonstration.** Ask your computer dealer to demonstrate Multiplan's powerful, user-oriented Multi-Tool™ features. They'll show you how Multiplan's unique capabilities provide you time-saving tools that help you answer the toughest question in business, "What if..." And still get back to J. B., tonight.

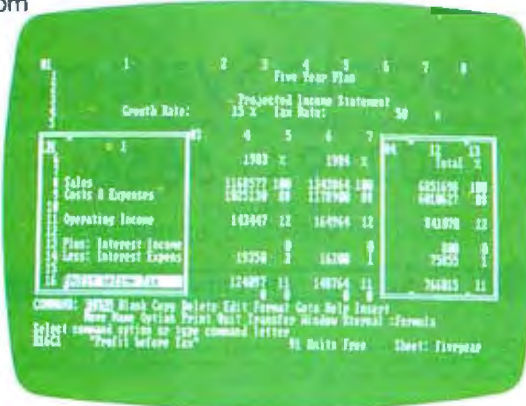

## MICROSOFT

MICROSOFT CORPORATION  
10700 NORTHUP WAY  
BELLEVUE, WASHINGTON 98004

Apple II is a registered trademark of Apple Computer, Inc.  
CP/M-80 is a registered trademark of Digital Research, Inc.  
Microsoft, Multiplan and Multi-Tool are trademarks of Microsoft Corp.



# SANYO PLUS



Only from Scottsdale Systems, the Sanyo Plus, only \$2295.

You get a Sanyo MBC-1000, an all-in-one 64K Z-80A (4 MHz) computer with a built-in, 12", high res. Sanyo green-phosphor 25x80 display.

The detached keyboard features 5 special function keys and a 10-key pad. The MBC-1000 comes complete with a serial port, a parallel port, and room for three additional cards.

Plus we've added a disk drive to give you dual 5 1/4" drives and a total formatted disk capacity of 624K.

Plus Free Software:

**CP/M<sup>®</sup>**: the most popular operating system.

**Sanyo Basic**: A subset of Microsoft Basic, the most popular version of basic.

**Diagnostics and Utilities**: Usually thrown-in only with more expensive systems.

**Wardstar<sup>®</sup> 3.0**: The most popular word processing software.

**PlannerCalc<sup>™</sup>**: The first spreadsheet in English.

**Games**: Biorhythms, Trek, Parachute and 17 others - just for the fun of it.

**Special Offer**: Order a Sanyo Plus and we'll throw-in a complete integrated business package with General Ledger, Accounts Receivable, Accounts Payable, Payroll, Inventory for \$99.

No dealers please. F.O.B. Scottsdale. 90 day warranty.



# \$2295

### TELEVIDEO



Now backed locally by T.A.W. Built-in CRT, detachable keyboard, dual floppys w/750K formatted capacity, 64K, CP/M and more. Special: Telesolutions — Wardstar TM and CalcStar TM w/system \$279.

802	\$2696
802H (10 MG.)	\$5049
806 (6-user) 10mg.	\$5295

### ALTOS



Our tech's favorite systems. From the lowest priced 3-user systems with either 2 or 6 MG. storage, to 40MG, 8-user 16 bit systems.

Add terminals, printers, and software and we can fully test and configure your system at low prices. Back nationwide by Moore Systems Service.

Series 5-15D	\$2295
Series 5-5D	\$4575
8000-10 w/MP/MR	\$6175
8600-12	\$8395

### ZENITH



**NEW**

#### IBM-PC Compatible

Introducing the Zenith Z-100, its the new 8/16 bit system that's CP/M, PC-DOS, and 5-100 compatible. Plus it's backed by 300 Zenith service centers nationwide.

Two built-in 320K 5 1/4" drives, 128K RAM, color graphics with control of eight colors and 144,000 dots, five 5-100 expansion slots, and a full feature keyboard:

Z-100	\$3249
Z-90-82 w/64K	\$2395
Z-89	\$2149

### NORTHSTAR



New low price on the incredible Advantage TM. Your choice GDS and BASIC, or GCP/M \$120. Let us burn and test your Advantage TM or Horizon and we'll back it with our own fast warranty service.

Advantage	Call
Horizon II	
64K Quad	\$2695
Advantage w/5 mg.	\$3795

### TERMINALS



Viewpoint JA Plus: New Viewpoint emulates Lear Siegler, Televideo, or Soroc. We're selling them at a lower price than others charge for older models.

\$489

Zenith ZT-11	\$559
Televideo 910	\$579
Televideo 925 <sup>2</sup>	\$739
Televideo 950 <sup>2</sup>	\$927
Zenith Z-19	\$689
Dialog 80 Amber	Call
Dialog 30	Call

<sup>1</sup>with built-in modem  
<sup>2</sup>extra pg. memory #30-installed



## Scottsdale Systems Ltd.

6730 E. McDowell Road, Suite 110, Scottsdale, Arizona 85257



(602) 941-5856



Call 8-5 Mon.-Fri.

(We Expon) TWX 910-950-0082 (IMEC SCOT)

### SERVICE/ORDERING

**INTEGRATION:** Prices listed are for new equipment in factory sealed boxes with manufacturer's warranty. We will pretest your equipment, integrate your system, configure your software, provide special cables, etc. for an additional charge. Call for prices.

**ORDERING:** MAIL ORDER ONLY. Prices listed are for cash. No C.O.D.'s. We sell on a net 20 basis to Fortune 500 companies and Universities Charge cards add 2%. Prices subject to change, product subject to availability. AZ. residents add 5%. Personal checks take 3 weeks to clear. 0-20% restocking fee for returned merchandise. Shipping extra - products are F.O.B. point of shipment. CP/M and MP/M are registered trademarks of Digital Research.

### ON SALE



#### LOW COST

NEC8023A	\$474
Okidata 82A	\$419
Okidata 83A	\$669
Okidata 84	\$1059
Epson MX-80*	\$435
Epson MX-100*	\$719

\*Includes graftrax

#### HIGH SPEED

Prism 80	\$779
Prism 80 "loaded"	\$1395
Prism 132 "loaded"	\$1549
Zenith Z-25	\$1225
Anadex 9501A	\$1369
MT 1805	\$1645

#### LETTER QUALITY

SCM TP-1	\$649
Daisywriter 1000	\$1111
NEC 3510 w/trac.	\$1975
NEC 7710 w/trac.	\$2499

### CP/M<sup>®</sup> SOFTWARE

Wardstar	\$208	DaraStar	\$189
CalcStar	\$179	Supersort 1	\$139
Mailmerge	\$78	D BASE II	\$489
Spellstar	\$149	CrossTalk	\$129

Software sold only w/systems, not warranted for suitability.

### I/O DEVICES

Houston Instrument:		Hayes Smartmodem	\$219
Hi-Plot DMP-2	\$849	NEC 12"-G Monitor	\$169
Hi-Plot DMP-7/8	\$2057		
Hi Pad DT-11	\$669		

can build bridges from an informal intuitive understanding of a piece of the world to a formal understanding of that area.

The learner benefits from the structured nature of the activities, the immediate feedback, the possibility of a concrete approach to abstract ideas, and the emphasis on the methods of doing things rather than on the answers—the emphasis on *process* rather than *product*.

During the past 10 years, Logo has been used with children of all ages and all ranges of ability. It was noticed at Edinburgh (references 4 and 13), in the Brookline project (references 7 and 14), and with a Boston Children's Hospital subject (reference 11) that children who had learning disabilities responded particularly well to the use of Logo. The MIT Logo Group has been working with physically disabled children at the Cotting School in Boston (since 1978); with autistic and other emotionally disturbed children at the League School for Autistic Children, Newton, Massachusetts (for the past year); and dyslexic children at the Carroll School in Lincoln, Massachusetts (just beginning).

For physically or learning-disabled children, the computer allows entry into worlds in which their weakest areas are not the primary means of access. For autistic children functioning at a low cognitive level we can simplify the computer-based learning environment until they are able to engage in *self-initiated and self-driven* activity. This can lead, for example, to the beginnings of an understanding of cause and effect that comes from the one-to-one correspondence between an action taken and the response it produces. Logo provides a tool for diagnosis and remediation (references 10 and 11), as well as serving as a learning environment.

In this article we describe several ways in which we have been using computers with educationally disabled children, helping them build their basic intellectual skills, while developing a stronger sense of confidence, self worth, and control over their environments. Each of the ap-

proaches is illustrated by a brief anecdote, showing how it helped a particular child make progress in learning. More detailed descriptions of these approaches and their results are available from the MIT Logo Group (see references footnote for the group's address).

### A Tool for Learning and Communication

A severe physical handicap imposes a dependent, passive role on its victim. The uncompromising way in which Logo places initiative and control in the hands of the users allows them to have a direct effect on their environment. The Logo experience is often the first in which disabled students *tackle problems which require them to initiate solutions, try them out, respond to feedback, and decide whether to change track or to persist*—all those things that tend not to happen in the dependent situations that typify their lives and most of their schooling.

A major problem for severely disabled individuals with little motor control is that of being totally dependent on other people to produce a written record of their and other people's thoughts. Computer files provide a way of keeping notes, functioning as a scratch pad—try solving a complex algebraic expression or editing a manuscript without writing anything down. The effect of this unleashing of trapped intelligence can be quite dramatic.

*Mike was 17 years old when he first met a computer. He has cerebral palsy, involving all four limbs, more marked on the left side. His speech is severely affected and can be understood only with difficulty. He has sufficient motor power to control his wheelchair, but has never used a pencil. For three years Mike spent 6 to 9 hours a week at the computer and was brought to the Logo laboratory weekly during vacations when the*



## I See a Brilliant Future

for the APPLE II with the  
Ren Tec RGB Color Monitor Interface

**Now your Apple can have RGB  
Color—the sharpest image  
available in technology today.**

- ★ Interfaces to NEC and other RGB monitors
- ★ Compatible with 40 and 80 column boards
- ★ Fully supports semi-graphic and full-graphic modes
- ★ Plugs into I/O slot

**APPLE/RGB Color  
Monitor Interface .. \$225.**

---

**OTHER REN TEC PERIPHERALS:**

<p><b>IBM</b></p> <ul style="list-style-type: none"> <li>★ IBM/Diablo Printer Interface .. \$160.</li> <li>★ IBM/Spinwriter Interface .. 160.</li> <li>★ IBM/RGB Color Monitor Cable 36.</li> </ul>	<p><b>NEC PC-8000</b></p> <ul style="list-style-type: none"> <li>★ Wedge .. \$595.</li> <li>Additional Peripheral and Memory Capabilities</li> <li>★ RGB Color T.V. Converter .. 149.</li> <li>★ RS-232 Interface Card .. 159.</li> <li>★ 32K Memory Board .. 199.</li> <li>★ Speech Synthesizer .. 295.</li> </ul>
---	---

Authorized Distributor for:  
NEC, Olympia, Eagle, Konan

---

DEALER INQUIRIES WELCOME

**RENAISSANCE TECHNOLOGY CORPORATION**

1070A SHARY CIRCLE, CONCORD, CA 94518 • (415) 676-5757

# STAR.

WE'RE MAKING A

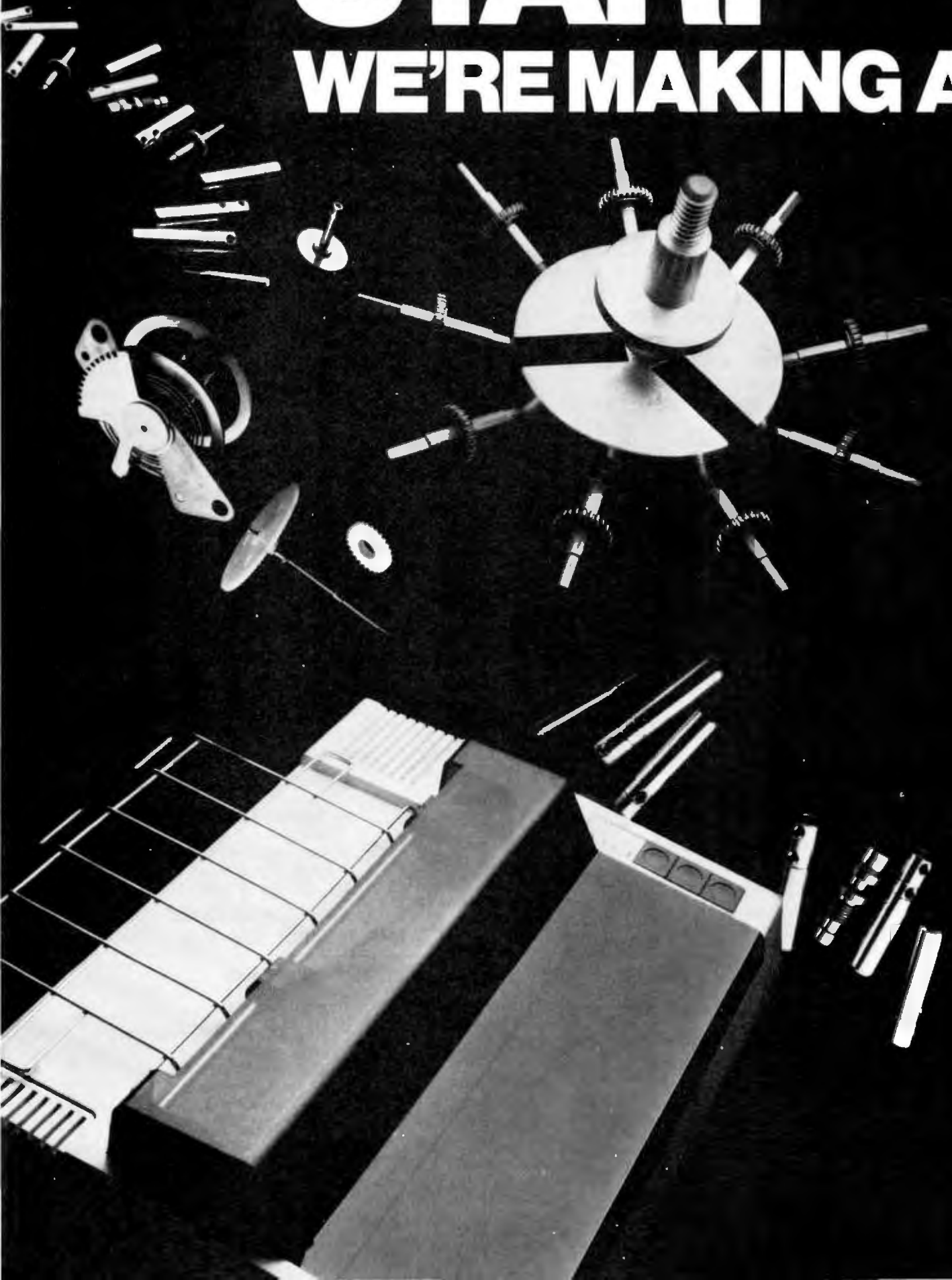

# NAME FOR OURSELVES.

## Building a reputation for quality printers of astronomical value, from components on up.

Making a name for ourselves in printers is only natural when we've been making the highest quality precision parts for over 30 years. And although Star's reputation in microperipherals has only begun to grow, the watch and camera industries worldwide have been relying on Star components for nearly 3 decades.

Quality manufacturing is what we're building our reputation on. Star is a true manufacturer, not merely an assembler. We even design and manufacture the computer controlled machines that make our parts. With unlimited production capabilities, Star's factories can operate 365 days a year, 24 hours a day, producing more than 100 million parts a month. It is this kind of productivity and total quality control that assures you of get-

ting the very finest printer for the very lowest price.

And the best product for less is what you can depend on getting from Star. Star offers you a full line of reliable printers, printers with divergent technologies to meet your specific needs. And there's more. You get a low cost, high quality printer with a wide spectrum of interfaces to choose from—backed by Star's superior service network, there if you need it.

Star. We're going to be the quality printer you can count on, from components on up. And that's no pie in the sky promise.

**star**  
MICRONICS · INC

MAKING A NAME FOR OURSELVES

200 PARK AVENUE, NY, NY 10166

Circle 437 on inquiry card.

# OUR PRICES WILL GET YOUR ATTENTION. OUR SERVICE WILL KEEP IT.

## SOME OF OUR PRODUCTS:



### TELEVIDEO COMPUTERS

	LIST	SELL
TS-801 Computer	3295	2000
TS-802 Computer/ Terminal	3495	2795
TS-802H Computer/ Terminal	5995	4555



### NORTHSTAR COMPUTERS

	LIST	SELL
ADVANTAGE ADV-2Q-64K	3999	Call
HORIZON HRZ-2Q-64K	3599	Call
HRZ-1Q-64K-HDS	6695	Call

### ZENITH DATA SYSTEMS MONITOR

	LIST	SELL
ZEN-VM-121 12" Green Screen Monitor	160	110

Ask us about other fine Zenith Products.



### TELEVIDEO TERMINALS

	LIST	SELL
910 Terminal	699	565
925 Terminal	995	720
950 Terminal	1195	910

### TELEVIDEO SOFTWARE

	LIST	SELL
TELE SOLUTIONS WordStar Plus CalcStar Packaged For Televideo	790	500



### PRINTERS

	LIST	SELL
Okidata 82 A	719	490
Okidata 83 A	1195	740

We also handle NEC, Epson and Smith-Corona. Call for prices and availability.



### MICROPRO SOFTWARE

	LIST	SELL
WordStar	495	275
Apple WordStar— 16 Sector	375	235
SpellStar	250	155
MailMerge	150	89
DataStar	350	235
SuperSort	250	165
Apple MailMerge— 16 Sector	Call	
CalcStar	295	190

### PLUS MANY OTHER FINE PRODUCTS:



computer at the school was not available to him. Here is an example of Mike's writing when he first entered the Logo program.

"I ment Dr. Sileva Where, Jose Valente and Gary Drescher on October 5, 1978 at 9:32:47 AM. which the compuer I was so excized it like being it a waiting & maternace room at a hospital whiting to fine it oot's a boy or a grail."

Two years later he produced a letter of which the following is an extract:

"My name is Michael Murphy. I am the person whom your mother saw on "PM Magazine." I attend the Cotting School in Boston mass. I have been work with the compuers for about two and a half years. The name of the system is "LOGO." It has open many new doors for me."

Mike has become a competent computer programmer and is now a computer science student at the University of Massachusetts, Boston campus. He is now writing papers at an acceptable level for a college freshman. Three other seniors on the project have also started computer science courses at the college level.

### A Simpler Version of the System

For those who cannot manage as many keystrokes as Logo requires, e.g., FD 100, because of their youth or physical or cognitive disability, simpler Logo systems are easy to set up. An example is the Instant Program, on the utilities disk of Terrapin Logo (reference 1). With the Instant Program, a single keystroke will generate a turtle movement, e.g., F for forward, B for back, R for right turn. Larger primitives can be defined in the same way, e.g., a ready-made square, a quarter circle, or a triangle, each available by pressing a single key. It is also possible to record each keystroke. This allows the user to name the picture and then to use the named picture, alone or as part of a larger design, making subprocedurization possible in this simplified world (see reference 3, for a discussion of procedures and subprocedures). For some children, we have used a hardware button box. This is a plastic box with large, well-spaced

## UNDER NEW OWNERSHIP

Don't let anyone tell you that service and prices are a trade-off. We're proof you can have both.

Our service begins even before you call. Because we've taken the trouble to select the most reliable equipment and products for sale.

We'll discuss your needs, and help you make the right decision. Then we'll test and configure equipment to be sure it's compatible with

your system. We'll even initialize your software.

Our repair parts stock and technical expertise will help you keep your system up, and hold maintenance costs down.

So go ahead and be amazed by our low prices, but remember: the best is yet to come.

Prices change daily—call for current pricing.

In California call 714-449-0603.

CALL TOLL FREE:  
**800-854-7635**



## AUTOMATED EQUIPMENT, INC.

8775 Olive Lane, Suites I & J, Santee, CA 92071



# FMS-80. THE TWO DOOR DATA BASE PLUS



Door # 1: Reports you'll use *today*.  
Door # 2: The sky is the limit.

**W**e've split the proven, best-selling FMS-80 micro data base manager into two parts. And we've split the price.

Part one (FMS-81) gives you the essential file and reporting features. You can quickly create programs with input questions a clerk can understand, and with reports a manager can use.

And FMS-81 with its new manual, is so easy to use, you'll be generating reports the first day. FMS-81 sells for \$495.

Part two (FMS-82) has all the fancy stuff. Including an Extended File Maintenance language that lets you perform virtually unlimited manipulation on up to 19 different data files simultaneously.

Using FMS-82, you or your computer dealer can make FMS-80 do *just about anything*. FMS-82 sells for \$495.

Naturally, FMS-82 is fully compatible with all the files and functions you generate with FMS-81.

FMS-81 is so useful, it might seem like you'll never need FMS-82.

But as you expand your use of computers, isn't it nice to know it's there?

The FMS family runs under CP/M, MP/M, CDOS, and Turbodos. Call or write today for a brochure detailing the extensive capabilities of the Two Door Data Base Manager, and the name of your nearest dealer.

You'll be impressed.

**Systems Plus, Inc.**



1120 San Antonio Road  
Palo Alto, CA 94303  
(415) 969-7047

**djr** product  
DJR Associates, Inc.  
2 Highland Lane  
North Tarrytown,  
NY 10591

FMS-80, FMS-81, FMS-82  
TM DJR Associates  
CP/M, MP/M TM Digital Research  
CDOS TM Cromemco  
Turbodos TM Software 2000, Inc.

Circle 448 on Inquiry card.

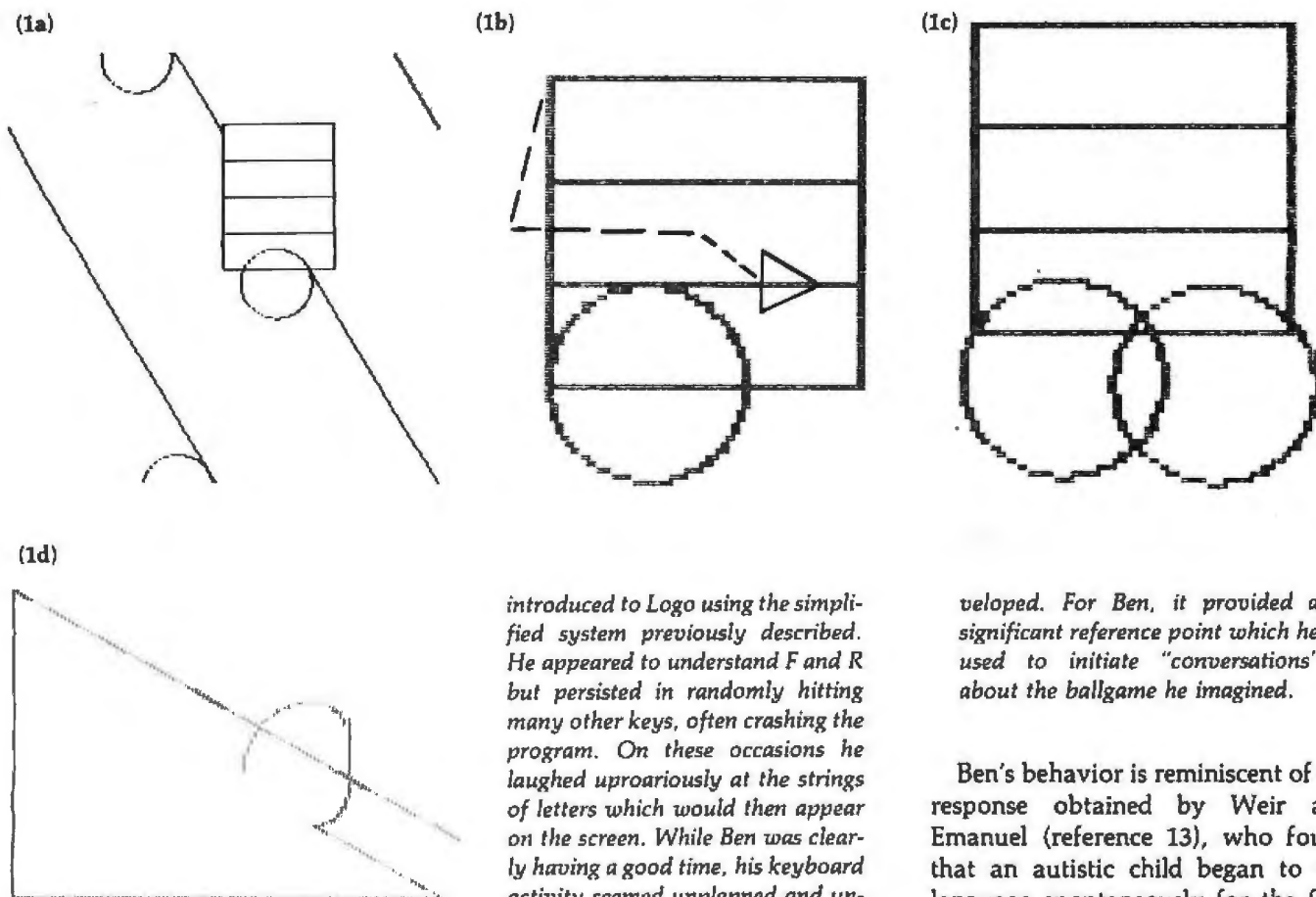

**Figure 1a-d:** Ben, a 6-year-old with cerebral palsy, made progress when he was provided with a button-box interface instead of a keyboard. Figure 1a represents one of his first efforts to draw a car. By the time of his next session he had gained much more control and was able to move the turtle easily and draw a second wheel for his car (1b and 1c). The drawing shown in figure 1d was made when he went back to using the keyboard at a later session. His "ballgame," while obviously simplified, was carefully planned and executed, without the randomness associated with his initial keyboard efforts.

buttons, each representing a primitive, e.g., FD 20 (references 8 and 13). This helps to prevent inadvertent, unintentional keystrokes, troublesome when involuntary movements are present.

Ben is a 6-year-old with cerebral palsy affecting all four limbs and speech. He makes sounds which, with patience and time, can sometimes be deciphered as recognizable words. He uses a communication board and a Handivoice. Ben was

introduced to Logo using the simplified system previously described. He appeared to understand F and R but persisted in randomly hitting many other keys, often crashing the program. On these occasions he laughed uproariously at the strings of letters which would then appear on the screen. While Ben was clearly having a good time, his keyboard activity seemed unplanned and unrelated to what was happening on the graphics screen.

We substituted the seven-button hardware button box, giving him F (forward without drawing a line), T (right turn), Q (quit), a rectangle, a square, a circle, and a line equivalent to FD 10. A session or two after the introduction of the button box, he began drawing several cars. The first one looked like Figure 1a. During the next session he made a similar car and was asked, "Doesn't it need another wheel?" He paused, smiled, then moved the turtle on the path indicated in Figure 1b, carefully adjusted it, and made a second circle, as shown in figure 1c.

In a recent session, as he entered the computer room he was asked, "Do you want to use the button box today?" He indicated no. "Do you want to use the keyboard like Eva and Nicky (two of his classmates)?" Ben said, almost distinctly, "Eva and Nicky."

Back at the regular keyboard, Ben's random hitting of keys had all but disappeared. He created the drawing in Figure 1d, which he named "ballgame," typing the word into the computer himself. To us, this picture appears flat and unde-

veloped. For Ben, it provided a significant reference point which he used to initiate "conversations" about the ballgame he imagined.

Ben's behavior is reminiscent of the response obtained by Weir and Emanuel (reference 13), who found that an autistic child began to use language spontaneously for the first time ever during his Logo sessions. Ben's Logo work provides his teachers with a window into his thinking and a medium through which he and they can communicate. This clear person-to-person communication is not routine for Ben; it emerges out of interaction around something of his own creation, of interest to him, under his control. For nonverbal children, carefree conversation is impossible. The danger for such children is that they will limit their communication because the results are so often misinterpreted or fall so short of the complexity or length of what they would like to express. The amount of energy Ben puts into his Logo work, the effort with which he manipulates the buttons (not a trivial activity for him), and the length of time he spends before becoming tired, all indicate that this activity motivates exploration, communication, and probably language development.

Motivation to participate in the Logo project is so high that children without special adaptive devices invent their own ways of handling a

# MICRO



**BUSINESS WORLD INC.**  
Information Line (213) 996-2252  
TOLL FREE MAIL ORDER LINES  
(800) 423-5886 Outside Calif.

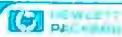

## HP83

LIMITED QUANTITY  
MSL **\$795.00**  
2250.00 *Save* 1455.00



## SPECIAL OF THE MONTH

Put a Genie In Your Computer Intelligent Printer

Interface Card

Works With

- Integer Basic
- Applesoft\*
- Pascal 1.0 & 1.1



OUR PRICE

**\$119.00**

MSL 159.00 *Save*

■ CP/M\*\*

\*Applesoft is a registered trademark of Apple Computer, Inc.  
\*\*CP/M is a registered trademark of Digital Research.

40.00

### MICRO-SCI

APPLE II+ COMPATIBLE DRIVE



W/ CONTROLLER		W/O CONTROLLER	
MSL	OUR PRICE	MSL	OUR PRICE
549.00	429.00	449.00	379.00

*Save* COMPARE TO APPLE DRIVE **216.00** *Save* COMPARE TO APPLE DRIVE **146.00**

APPLE IS A REG. TRADE MARK OF APPLE COMPUTER

### IBM

PERSONAL COMPUTER

INCLUDES:

- 2 Drives
- Colour Graphic Board
- 64K Memory



CALL FOR PRICE

\*Subject to availability

### TP1 SMITH CORONA

DAISY WHEEL PRINTER

Letter Quality

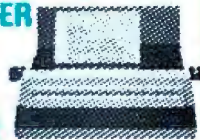

OUR PRICE **\$599.00**

MSL 895.00 *Save* 296.00

### CASIO FX9000P

PERSONAL COMPUTER POWERFUL CA-BASIC



NEW

AND C/MOS-RAM

MSL OUR PRICE **\$599.00** *Save* 396.00

### LE MONITOR

METAL CABINET



9" GRN. PHS. MONITOR  
12" GRN. PHS. MONITOR  
1 Yr. Warranty

MSL OUR PRICE **\$119.00** *Save* 70.00

### APPLE II PLUS 48K

\*Subject to availability



CALL FOR PRICE

APPLE IS A REG. TRADEMARK OF APPLE COMPUTER

### FRANKLIN BUSINESS SYSTEM



Franklin Ace 100 system • 64K • Disk Drive with controller card • 12" green phs. video monitor.

**\$1695.00**

SAVE \$1000 COMPARED TO APPLE SYSTEM

### VIC 20 EXPANSION

OUR PRICE **189.00** *Save* 40.00

MSL 229.00

- FEATURES
- 7 expansion slots
  - All aluminum construction
  - Large power supply with toroidal transformer
  - 5 volt supply direct of the VIC 20 for cooler operation
  - 24 volt supply for the Arlon Commodore and others
- Micro VIC Printer • Detachable cover protects cartridges • Houses VIC and Expansion in one portable unit • Holder for RF modulator • Supports all VIC 20 cartridges from Arlon Commodore and others

### AXIOM DOT MATRIX GP 100



8 1/2" wide paper

MSL OUR PRICE **\$269.00** *Save* 120.00

### HP 125



OUR PRICE **\$1975.00**

MSL 2750.00 *Save* 775.00

### DUAL MASTER DRIVE

MSL OUR PRICE **\$905.00**

### XEROX 820

WORD PROCESSING SYSTEM (INCLUDES SOFTWARE)



MSL OUR PRICE **\$2649.00** *Save* 846.00

### NEC STUDENT SYSTEM 64K



\*NEC PC 80001  
\*NEC PC 8012  
\*NEC PC 8031  
12" Grn Phs Video Monitor

MSL OUR PRICE **\$2095.00** *Save* 744.00

### HP-87



MSL OUR PRICE **\$1749.00** *Save* 746.00

### COMMODORE VIC-20



Vic TV Modul \$19.00  
Vic Cassette \$69.00  
Vic Disk Drive \$5 Call  
Vic 5 Pack program \$44.00

MSL OUR PRICE **\$235.00** *Save* 64.00

### EPSON

INCLUDES GRAFTRAX



OUR PRICE *Save*

MX 80	MSL 645.00	OUR PRICE 429.00	216.00
MX 80FT	745.00	535.00	210.00
MX 100	995.00	669.00	326.00

### COMMODORE STUDENT SYSTEM



4032 - 32K 40 COL CRT  
4940 - DUAL DISK DRIVE  
MSL OUR PRICE **\$1978.00** *Save* 612.00

WE RESERVE THE RIGHT TO CORRECT TYPOGRAPHICAL ERRORS. THIS AD SUPERCEDES ALL PREVIOUS ADS

### RADIO SHACK 48K

TRS 80 W/2 DRIVE MOD III



MSL OUR PRICE **\$1799.00** *Save* 696.00

1 Year Extended WARRANTY **\$99.00**  
INQUIRE

AVINGS SERVICE ELECTION ATISFACTION

**MICRO BUSINESS WORLD**  
10000 CA CAL 11111 FREE 1-800-423-5886 N CAL 213-996-2252  
Name: \_\_\_\_\_  
Address: \_\_\_\_\_  
City: \_\_\_\_\_ State: \_\_\_\_\_ Zip: \_\_\_\_\_  
Description: \_\_\_\_\_ Price: \_\_\_\_\_ Total: \_\_\_\_\_  
Certified Check or M.O. Allow 2 weeks clearance for personal check  
Bank Wire Transfer  
CREDIT CARD # \_\_\_\_\_ Signature: \_\_\_\_\_  
Telex: 162852 Answer: MICKO TZNA  
\*California residents add 6% sales tax  
\*\*Add 3% Shipping & Handling - Add 3% surcharge for credit cards. Orders arrival be refused unless accompanied by payment including shipping handling and tax where applicable.  
TOTAL ORDERS TAX F APPLICABLE\*\* SHIPPING & HANDLING\*\* TOTAL ENCLOSED \$



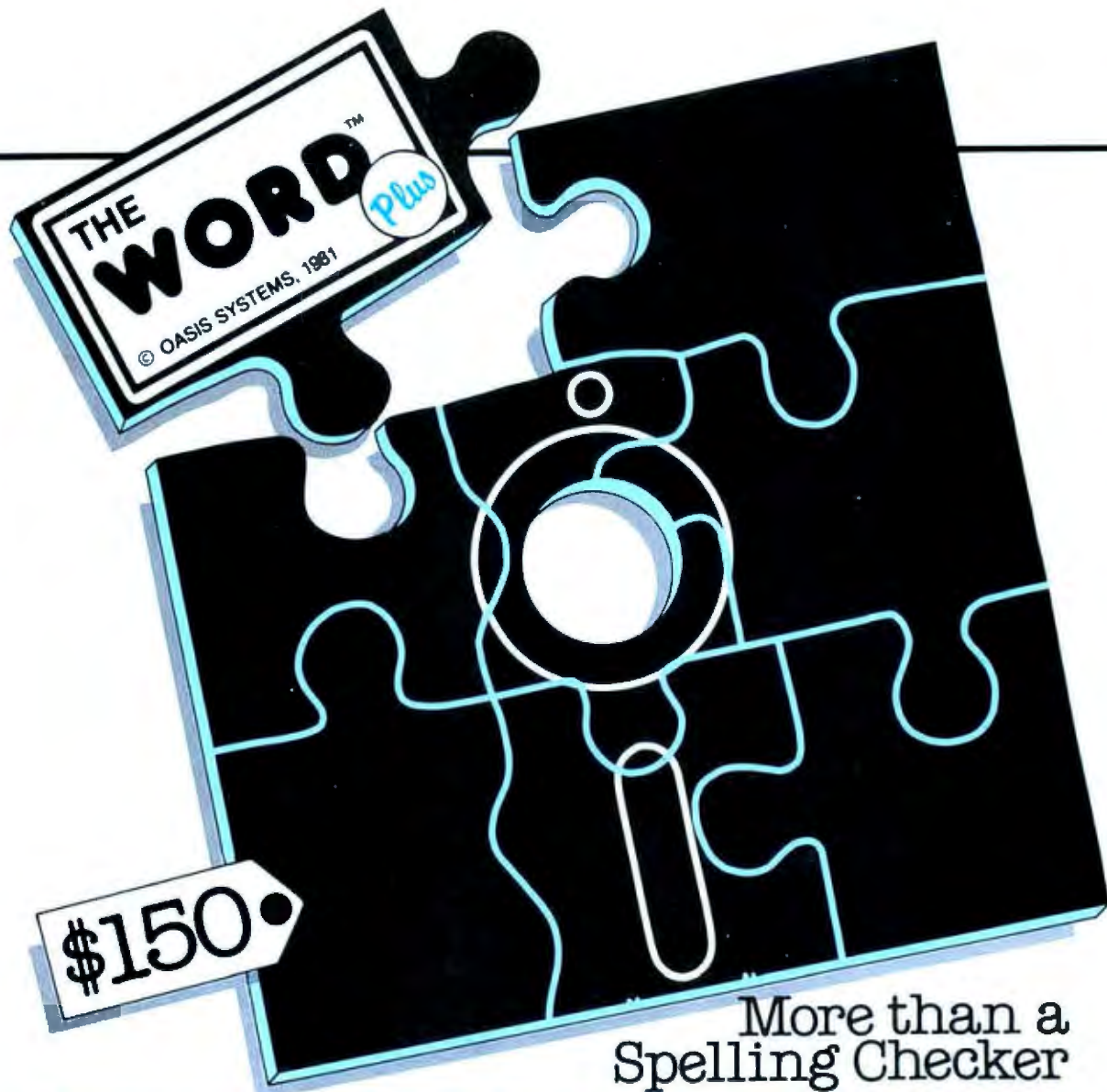

More than a  
Spelling Checker

## THE COMPLETE TOOL

The WORD PLUS has many features that SpellStar™ and other competitors leave out. The WORD PLUS finds errors, shows them to you *in context*, and with your consent, automatically corrects them throughout the text. SpellStar does not correct errors.

**Versatile** The WORD PLUS works with almost any CP/M® based word processor. SpellStar only works with WordStar.™

**Accurate** The WORD PLUS offers a 45,000 word vocabulary without the compromise of suffix stripping. SpellStar has only 20,000 words.

**Convenient** The WORD PLUS helps you find the correct spelling by consulting its dictionary. SpellStar gives no such help.

**Fast** The WORD PLUS proof reads 10,000 words of text in less than two minutes.

### Many Extra Features

The WORD PLUS offers automatic hyphenation, text analysis, and fast word counting. Also solves crossword puzzles, locates anagrams and finds rhyming words.

**Inexpensive** \$150 ... a low cost for freedom from the anxiety of misspelling.

The WORD PLUS - Clearly the Best Choice.  
For more information call Wayne Holder at

**OASIS  
SYSTEMS**

714-291-9489

2765 Reynard Way  
San Diego, CA 92103

\*SpellStar and WordStar are trademarks of MicroPro Intl.  
CP/M is a registered trademark of Digital Research, Inc.

keyboard, for example, by using a pencil between their lips. In some cases, we have seen dramatic improvements in control of direction and accuracy of arm, hand, and finger movement.

### Mobilizing Existing Understanding

Experts differ from naive students in the degree of meta-level knowledge they possess. The facts of a subject are relatively easy to transmit. Learning only these, without an appreciation of their use, constitutes rote learning. Real understanding includes appropriate knowledge about when to use particular facts and operations and about how to order operations so as to achieve a particular goal. This is knowledge about knowledge, or meta-knowledge. Just how to facilitate the acquisition of meta-level knowledge is the great challenge. One possibility is to try to hook into already existing meta-knowledge.

A growing child spontaneously learns how to do certain things, including the procedural-control knowledge we are talking about. Connecting with that existing knowledge is the purpose behind the learn-by-doing school. For example, the child's intuitive knowledge of his own body movements as he navigates in space includes such sophisticated understanding. Mobilizing this to provide a way into mathematics is just what Papert has done with his turtle geometry (references 2 and 5).

Now consider the unusual childhood of an individual physically disabled from birth. If the disability is severe enough, the child will not have handled objects as part of growing up, will not have played with blocks as an infant. The development of an understanding of spatial concepts depends on a coordination of several kinds of information—tactile, visual, motor, and kinesthetic (sensation in muscles and joints of the moving part)—generated by handling objects, moving around in space, and so on. Hence the child with lack of this experience is at the risk of developing a deficit in spatial competence.

The degree of deficit is difficult to assess in individuals with severe

motor disabilities. For example, when children with cerebral palsy are tested for some particular component of visual perception, they will obtain progressively lower scores as the motor component of the test increases (reference 15). It has, until now, been necessary to convert tasks such as the Piagetian Seriation task into a multiple-choice form in order to use them with people with severe motor restrictions. This precluded an examination of the processes involved in carrying out the relevant maneuvers.

We have exploited the possibilities of an interactive graphics situation by creating *graphics screen versions* of these assessment tasks. Using these screen tasks, we have found deficits in spatial reasoning in some people with cerebral palsy when they are asked to perform tasks involving ordering by length, shape recognition, spatial localization, and mental rotation. We have probed the nature of the underlying defect in several of these children (references 9 and 12). (See figure 2.)

### Filling the Gap with Logo

The Logo theme of the learner as model builder takes on a poignant significance for the physically disabled because lines on the graphics screen can become models of objects. Such graphics objects can supply manipulatory experience of a sort, involving a minimum of motor effort, by simply pressing a key. We have called these manipulations AS-IF actions (reference 6) and suggest that the Logo system provides a rich source of such activities. For the severely disabled child, the chance to find out about spatial relationships in the environment has been restricted by the dependence on others for mobility and by the lack of ability to draw, build, pour, pile, sift, put together, and take apart. The child can use the screen turtle to explore a defined and manageable spatial world in which to learn about shape, length, angle, size, position, and number; teachers can easily follow the process of exploration, structuring appropriate tasks as skills and confidence increase.

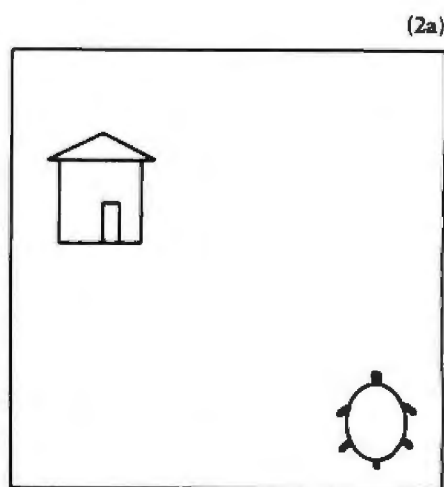

(2a)

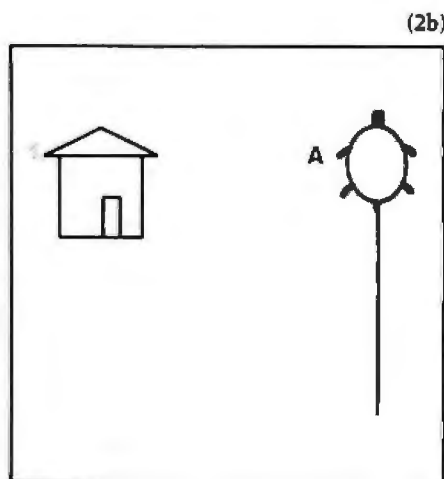

(2b)

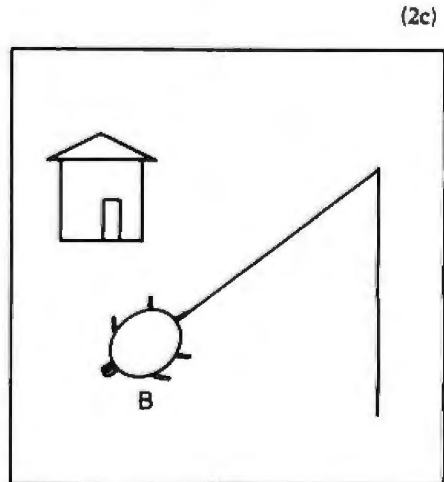

(2c)

Figure 2a-c: For Kate, a 13-year-old with cerebral palsy, the lack of meta-knowledge is quite remarkable. When asked to get the turtle into the house she moved forward unconcernedly until the observer asked, "Are you going towards the house?" (at A in 2b). She then turned and moved forward until the observer again asked the same question (at B in 2c). Kate was gradually introduced to elementary Logo. She is now defining shapes and using them as subprocedures of more complex pictures.

# Announcing The Most Powerful, Flexible, Sophisticated, S-100 Bus, Board Level System Ever Available.

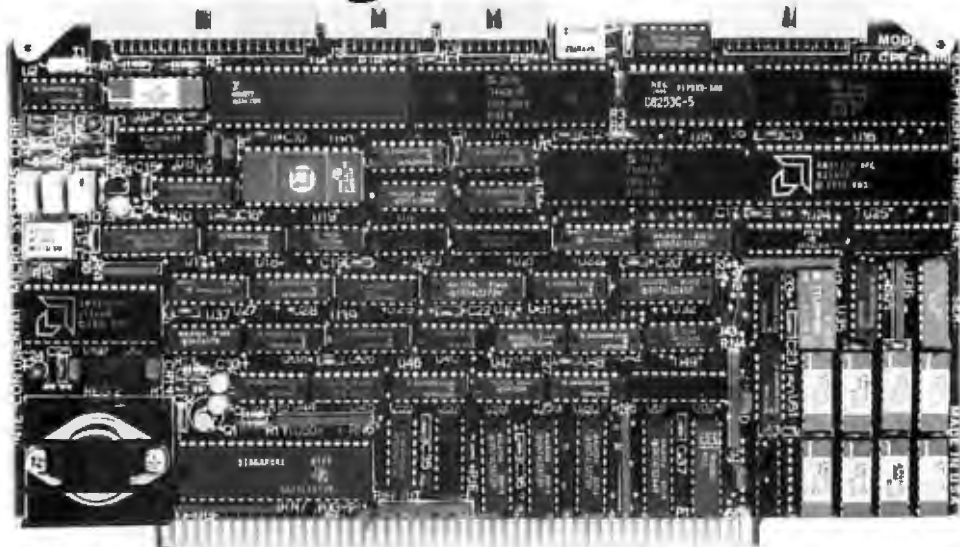

## CPZ-48000 From Intercontinental Micro Systems

### No bull, just a beefed up product

A lot of people have been claiming the title of best S-100 bus, board level micro. Some with only prototype or paper boards. Intercontinental Micro's CPZ-48000 is in production now, and we think it's the most powerful. Here's why:

- Z80A™ based system. Complies with IEEE 696.1/D2 S-100 BUS specifications.
- Single or Double Density Floppy Disk controller. Controls up to four 8" or 5 1/4" floppy disk drives in either DMA, Interrupt or Programmed I/O mode.
- 64 Kbytes of onboard Dynamic RAM with Memory Bank Selection of 4 Kbytes to 64 Kbytes under software control.
- Four Channel Direct Memory Access Controller.
- Two synchronous or asynchronous Serial I/O channels with one channel programmable in either DMA, Interrupt or Programmed I/O mode.
- Two Parallel I/O channels with one channel programmable in either DMA, Interrupt or Programmed I/O mode.
- Memory Management capable of addressing 16 Megabytes of system memory.

- Eight Vectored Priority Interrupts chained together with I/O Interrupts for use with Z80 Mode 2 Interrupts.
- Provisions for either a 2 Kbyte or 4 Kbyte onboard EPROM (Monitor in a 2 Kbyte EPROM supplied with board.)
- CP/M™ and MP/M™ operating systems available. TurboDOS™ and CP/NET™ available soon.
- Turbo-Disk™ Implementation included.

### Flexibility

CPZ-48000 can be used in many applications, including:

- Single board, stand alone computer
- Network master. Handles IBM Bisync, HDLC and SDLC protocols
- Multiuser host
- Multiprocessor host

### We've Got Personality

Power and flexibility are great, but not enough. You've got to be able to interface with a variety of peripherals, and you get tired of nearly redesigning stock boards for your applications. Intercontinental Micro Systems' complete line of "Personality" boards combine to make the CPZ-48000 compatible with: Centronics, 8" floppy disks, 5 1/4" floppy disks,

full modem and RS232C interfaces. NEC, Diablo, Qume, Archive and RS422 high speed serial interfaces available soon.

### Not only a great product, but a great line of products

Intercontinental also manufactures a 256K, 16K increment, fully bank selectable memory board, compatible with Cromix™ as well as other popular systems. Also, our hard disk controller controls both 5 1/4" and 8" units.

If you're looking for sophisticated S-100 bus board level computing for anything from process control to a multiuser host look to Intercontinental Micro. Call or write for further information and pricing. Dealer inquiries are welcome.



1733 South Douglass Road, Suite E  
Anaheim, California 92806  
(714) 978-9758 • Telex: 678401-TAB-IRIN

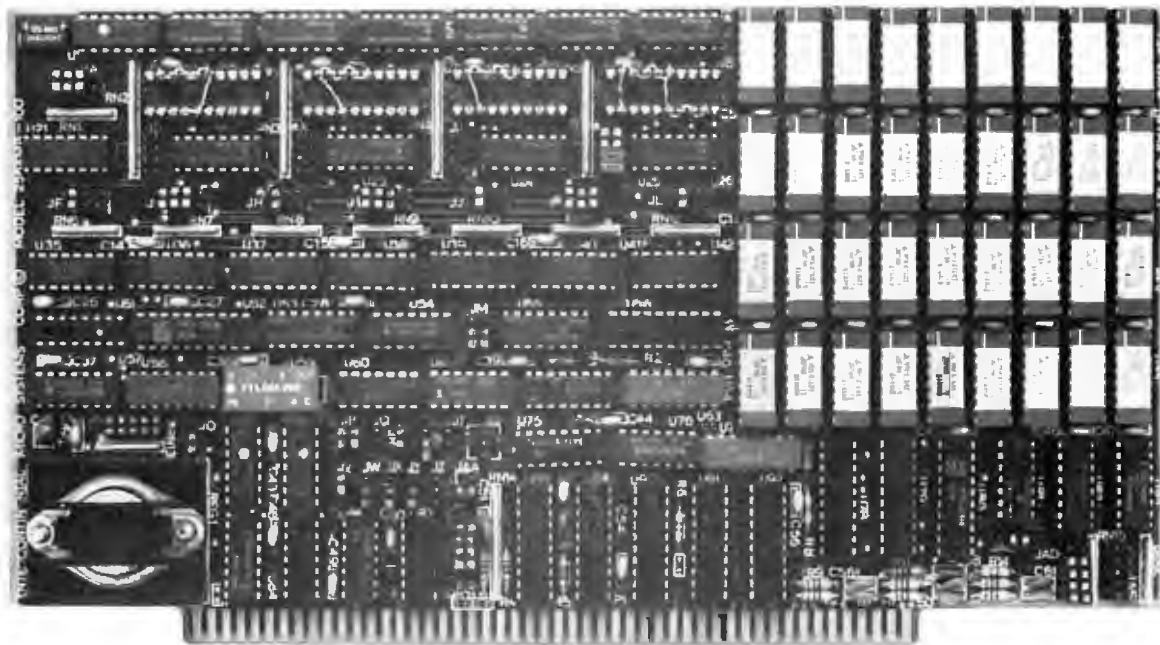

# How to Get 256K of 16K Increment Bank Selectable Memory or 2 Megabytes of Contiguous Memory on One S100 Board

The 256 KMB-100 from Intercontinental Micro Systems is one of the most flexible and easily integrated S100 bus, 256K memories available today. Its advanced features include:

- Complete Cromix™ CP/M™ MP/M™ and other major systems compatibility—up to 16 users are now possible on a Cromemco System.
- Bank selectable in any combination of 16K banks (e.g. 4 64K users, 8 32K users, 16 16K users or any other combination.)
- Up to 2 contiguous megabytes are easily configurable.
- Configures for phantom deselection.
- Deselectable on 4K boundaries from 4K to 64K.
- 4 MegaHertz operation, no wait states.
- Parity error detection through interrupts.
- IEEE 696.1/D2 Spec S100 Bus.
- One year complete warranty.
- Fully compatible with Intercontinental Micro's advanced CPZ-48000 S100 Bus single board CPU, which features: Z80 based system, single or double density floppy disk controller, 64K onboard dynamic RAM, 4 channel DMA controller and memory management.

The others are still talking about their S100 Bus 256K memories — ours is in production — call today for further details and applications information.



1733 South Douglass Road, Suite E  
Anaheim, California 92806  
(714) 978-9758 Telex: 678401-TAB-IRIN

\* Cromix is a trademark of Cromemco Inc. \*\* CP/M and MP/M are trademarks of Digital Research, Inc.

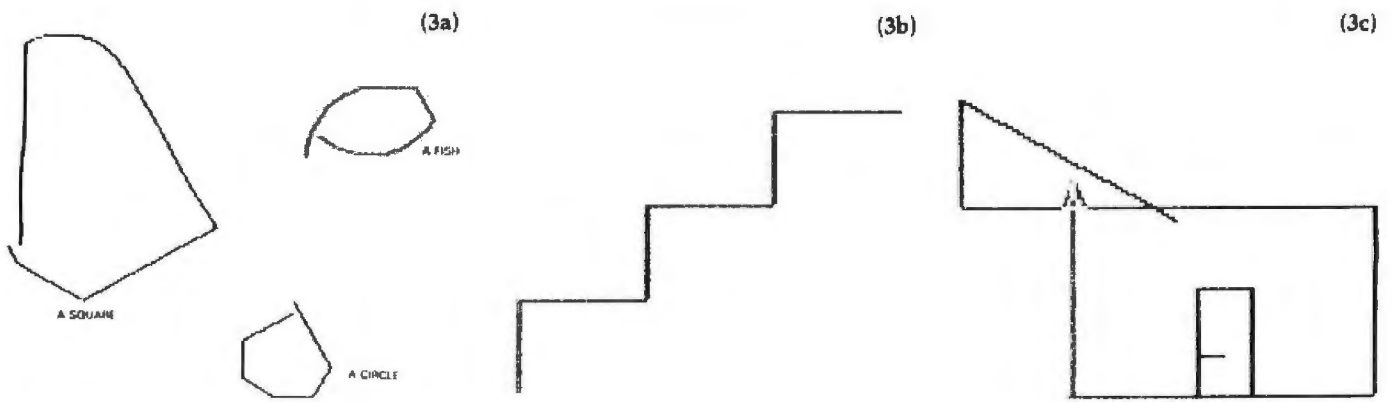

**Figure 3a-c:** The progress made by Nicky, a 7-year-old with cerebral palsy, is obvious. Figure 3a shows his initial attempts at drawing, using a simplified version of Logo. His shapes were irregular and poorly defined. By his seventh session he was able to consistently make right angles, as shown in 3b, and plan and execute a large design, as shown in 3c.

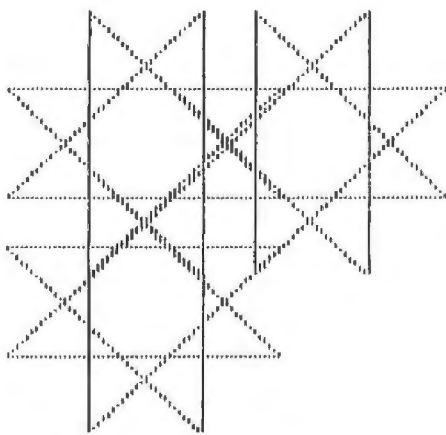

**Figure 4:** This drawing shows the work of Franky, a 10-year-old learning-disabled student. His mastery of turtle geometry is shown by the skill with which he arranged the three stars into a coherent design, despite severe difficulties with "paper-and-pencil" mathematics.

*Assessment of Nicky, a 7-year-old with cerebral palsy, indicated deficits in many spatial and language skills, including the ability to count accurately more than four objects, to match a small group of objects one-to-one, and to conserve number (know that the number of objects has not changed when their arrangement is changed).*

*In his early work with Logo, Nicky made small, closed shapes which appeared to be unplanned. He used a small portion of the screen, had difficulty turning the turtle in the direction he wished, was unable to make square corners (requiring three presses of T) or*

*match sides of objects. Examples of his first named pictures appear in figure 3a. His use of shapes is typical of a much younger child: he demonstrates closure but does not have firm categories for square or circle.*

*By his seventh session Nicky had made remarkable progress. He produced, without hesitation and without mistakes, the pictures he called respectively "STEPS," figure 3b, and "HOUSE," figure 3c, which showed the following characteristics: consistent use of three turns to make a 90-degree angle, matching of the lengths of opposite sides, use of a large area of the screen (both left and right halves), and a deliberate planned sequence to complete the picture symmetrically.*

### Revealing Hidden Strengths

A central issue addressed by the use of Logo with educationally disabled children is the discovery of hidden strengths. Often the needs of physically or learning disabled children become the focus of their educational experience with most attention given to learning how to cope with what they cannot do and little attention given to developing special gifts and talents. But a physical disability is not the only type that may hide spatial strengths. Growing evidence suggests that there is a category of learning-disabled children who have special ability in the spatial mode, an ability which is often ignored in school (reference 11).

*Franky is a 10-year-old learning-disabled child. His reading and spelling are several years below expectations for his age and grade; he knows some mechanical processes for computation, but these often break down. He was described in school records as having behavior problems, a short attention span, and a low tolerance for frustration. In his Logo work, Franky showed unexpected abilities to use numbers appropriately to create relationships in space, to use units larger than one as benchmarks for estimating length, and to remember individual as well as sequences of commands after a single exposure to them. Figure 4 shows an intricate star design which he created from smaller pieces. While creating his design, he needed to move a certain distance on the screen in order to place his next star where he wanted it. The distance was half of 75—a problem he is unable to compute. He looked at the distance on the screen and said, "Oh—it's about 37." An observer might think this was a lucky guess if he did not make such "guesses" with regularity.*

Franky seems to have some of the skills he needs to manipulate numbers when he uses a spatial model but does not have the meta-level knowledge necessary to translate this understanding to a purely numerical situation. If given a spatial model which he can use to figure out a problem, he can use it successfully, but the idea of using the spatial model does not oc-



# Software prices for hardnosed shoppers:

## DATAMOST

SWASHBUCKLER	29.95
CASINO	29.95
COUNTY FAIR	24.95
THEIF	24.95
SNACK ATTACK	24.95

## MICRO PRO

### APPLE CP/M®

WORDSTAR* †	222.00
SUPERSORT* †	145.00
MAILMERGE* †	79.00
DATASTAR* †	179.00
SPELLSTAR* †	119.00
CALCSTAR* †	149.00

### CP/M®

WORDSTAR	285.00
SUPERSORT	168.00
MAILMERGE	103.00
DATASTAR	235.00
SPELLSTAR	155.00
CALCSTAR	199.00

## BRODERBUND

TAWALA'S LAST REDDUBT	24.95
GALAXY WARS	20.95
ALIEN RAIN (AKA GALAXIAN)	20.95
ALIEN TYPHOON	20.95
APPLE PANIC	24.95
SPACE WARRIOR	20.95

## AUTOMATED SIMULATIONS

INVASION ORION	20.95
STAR WARRIOR	32.95
CRUSH, CRUMBLE AND CHOMP	24.95
TEMPLE OF APSHAI	32.95
RESCUE AT RIGEL	25.95

## MUSE SOFTWARE

ROBOT WARS	32.95
THREE MILE ISLAND	32.95
A B M	20.95
GLOBAL WAR	20.95
CASTLE WOLFENSTEIN	24.95
SUPER TEXT II	129.00

## ON-LINE SYSTEMS

MYSTERY HOUSE	20.95
WIZARD AND PRINCES	29.95
H/R FOOTBALL	32.95
H/R CRIBBAGE	20.95
MISSILE DEFENSE	25.95
CRANSTON MANOR	29.95
SABOTAGE	20.95
SOFT PORN ADVENTURE	24.95
PEGASUS II	25.95
EXPEDITER	73.95
TIME ZONE	69.95

## PERSONAL SOFTWARE

DESKTOP PLAN II	159.00
VISIPLLOT	189.00
VISITREND/VISIPLLOT	239.00
VISIDEX	199.00
VISITERM	79.00
VISICALC 3.3	199.00
VISIFILES	209.00
VISISCHEDULE	239.00
CHECKER KING	21.95
GAMMON GAMBLER	21.95
MONTY PLAYS MONDOPOLY	29.95
MONTY PLAYS SCRABBLE	34.95
MICRO CHESS 2.0	21.95

## SIRIUS SOFTWARE

BEER RUN	24.95
PHANTOMS FIVE	24.95
SPACE EGGS	24.95
PULSAR II	24.95
GAMMA GOBLINS	24.95
GORGON	32.95
SNEAKERS	24.95
EPOCK	29.95
COPS AND ROBBERS	29.95

## MORE GREAT APPLE GAMES

COMPUTER QUARTERBACK	32.95
THE WARP FACTOR	32.95
CARTELS AND CUTTHROATS	32.95
THE SHATTERED ALLIANCE	49.95
ULTIMA	33.95
RASTER BLASTER	24.95
FLIGHT SIMULATOR	27.95
INTERNATIONAL GRAND PRIX	25.95
SARGON II	28.95
SPACE QUARKS	24.95
DAVID'S MIDNIGHT MAGIC	29.95

## MICROSOFT

### APPLE

FORTRAN*	150.00
BASIC COMPILER*	315.00
COBOL*	550.00
Z-80 SOFTCARD	299.00
RAMCARD	149.00
TYPING TUTOR	17.95
OLYMPIC DECATHLON	24.95
TASC APPLESOFT COMPILER	145.00

### CP/M®

BASIC 80	299.00
BASIC COMPILER	319.00
FORTRAN 80	345.00
COBOL 80	568.00

## PEACHTREE

### APPLE CP/M®

GENERAL LEDGER	219.00
ACCT RECEIVABLE	219.00
ACCT PAYABLE	219.00
PAYROLL	219.00
INVENTORY	219.00

### S-100 CP/M®

GENERAL LEDGER	595.00
----------------	--------

ACCT. RECEIVABLE	595.00
ACCT. PAYABLE	595.00
PAYROLL	595.00
INVENTORY	595.00
PROPERTY MGMT	799.00
CPA CLIENT WRITE-UP	799.00

## APPLE BUSINESS SOFTWARE

DB MASTER (NEW)	169.00
DB MASTER UTILITY PACK	69.00
PFS: PERSONAL FILING SYSTEM	85.00
PFS REPORT	79.00
Z-TERM*	79.95
ASCII EXPRESS	63.95
HAYDEN APPLESOFT COMPILER	149.00
EASY WRITER-PRO	199.00
THE HOME ACCOUNTANT	54.00

## CPM® SOFTWARE

d BASE II	599.00
SUPER CALC	299.00
SPELLGUARD	239.00
PICKLES & TROUT CP/M® MOD II TRS-80	175.00
THE WORD	63.00

## EDU-WARE

PERCEPTION PKG.	19.95
COMPU-READ	24.95
STATISTICS	24.95
COMPU-MATH: ARITHMETIC	39.95
COMPU-MATH: FRACTIONS	34.95
COMPU-MATH: DECIMALS	34.95
COMPU-SPELL (REQ. DATA DISK)	24.95
COMPU SPELL DATA DISKS 1-4, ea.	17.95

## TRS-80 GAMES

INVASION ORION	20.95
TEMPLE OF APSHAI	34.95
HELLFIRE WARRIOR	34.95
STAR WARRIOR	34.95
RESCUE AT RIGEL	24.95
CRUSH, CRUMBLE AND CHOMP	24.95
STAR TREK 3.5	17.95
MISSILE ATTACK	18.95
STAR FIGHTER	24.95
OLYMPIC DECATHLON	24.95

## CALL US FOR THE LATEST APPLE, ATARI, IBM, AND TRS-80 SOFTWARE.

**Alpha  
Byte**  
**COMPUTER  
PRODUCTS**

31245 LA BAYA DRIVE, WESTLAKE VILLAGE, CALIFORNIA 91362

We guarantee everything for 30 days. If anything is wrong, return the item and we'll make it right. And we'll pay the shipping charges.

We accept Visa and Master Card on all orders; COD orders, up to \$300.00.

Add \$2.00 for standard UPS shipping and handling on orders under 50 lbs. delivered in continental U.S. Call for shipping charges over 50 lbs. Foreign, FPO and APO orders, add 15% for shipping. Californians add 6% sales tax.

Prices quoted are for stock on hand and are subject to change without notice.

To order or for information call  
**(213) 706-0333**

Modem order line: (213) 883-8976

cur to him independently if he is presented only with the numbers.

Many children like Franky have learning problems that are exacerbated because schoolwork in their weak areas is presented to them in their weakest mode. For these children, who are used to failing in school, the impact of Logo is three-fold: (1) it provides the possibility of experiencing success and demonstrating expertise; (2) it allows further development of the preferred spatial mode; (3) it is a diagnostic tool which suggests to teachers ways of creating more appropriate curriculum by harnessing spatial skills.

### Equal Access in a Technological World

It is important to attempt to lay to rest a serious misconception about computers in education. The connection of children and computers does not diminish the teacher's critical role in the learning process. On the contrary, because interaction with a computer opens a window into a child's thinking processes, a teacher is challenged to observe carefully, to develop hypotheses about the child's strengths and needs, and to help structure next steps for the learner. The questions for a teacher are the same here as in any educational situation: When should the teacher pose a new problem? When should the child be left alone to explore the possibilities? When should help be given and how much? How much frustration is appropriate in a new problem-solving situation? The computer can also become a powerful tool for the teacher in devising specific curriculum tailored to children's needs and harnessing the power of both graphics and text capabilities. Teachers have used or are developing Logo programs for teaching mathematics, physics, electronics, music, writing, and spelling.

We are only beginning to understand the extent to which the educationally disabled have been denied rights and opportunities. A user-controlled, flexible, extendable computer language is a powerful tool that can help bridge some of the gaps by

increasing educational access, expanding choices, improving communication, and enabling development of skills for vocational success and personal enrichment. ■

### References

1. Abelson, H. *Logo for the Apple II and Apple Logo*. Peterborough, NH: BYTE Books, 1982.
2. Abelson, H. and diSessa, A., *Turtle Geometry*. Cambridge, MA: MIT Press, 1981.
3. BYTE, August 1982. Language issue devoted to Logo.
4. Howe, J.A.M. and O'Shea, M., "Computational Metaphors for Children," *Artificial and Natural Intelligence*, ed. F. Klix, Deutsche Verlag, 1978.
5. Papert, S., *Mindstorms: Children, Computers, and Powerful Ideas*. New York: Basic Books, 1980.
6. Papert S. and Weir, S., "Information Prosthetics for the Handicapped," *Artificial Intelligence Laboratory Memo #496*. MIT, 1978\*.
7. Papert, S., Watt, D., diSessa, A. and Weir, S., Final Report of the Brookline LOGO Project. *Artificial Intelligence Laboratory Memo #545*. MIT, 1979\*.
8. Perlman, R., "TORTIS, Toddler's Own Recursive Turtle Interpreter System," *Logo Memo #9*. MIT, 1972\*.
9. Valente, J., "A Versatile Computer Tool for the Evaluation of Spatial Reasoning in the Physically Handicapped," PhD thesis in progress, 1982.
10. Weir, S., "Logo as an Information Prosthetic for the Handicapped," *D.S.R.E. Working Paper #9*, Division for Study and Research in Education, MIT 1981\*.
11. Weir, S., "Logo and the Exceptional Child," *Kilobaud Microcomputing*, Vol. 5, No. 9: pp. 76-84, 1981.
12. Weir, S., "Logo: an Information Prosthetic for Communication and Control," *Proceedings of the International Joint Conference on Artificial Intelligence*, Vancouver, B.C., 1981.
13. Weir, S. and Emanuel, S., "Using Logo to Catalyze Communication in an Autistic Child," *D.A.I. Research Report #5*, Department of Artificial Intelligence, Edinburgh University, 1976.
14. Weir, S. and Watt, D., "Logo: A Computer Environment for Learning Disabled Students," *The Computer Teacher*. Vol. 8, No. 5: pp. 11-17, 1981.
15. Zeitschel, K., Kalish, R. A., Colarussio, R., "Visual Perception Tests Used with Physically Handicapped Children," *Academic Therapy* Vol. 14: pp. 565-576, 1979.

\* References marked with an asterisk are available from the MIT Logo Group, 545 Technology Square, Cambridge, MA 02139.

# CALL YOUR LOCAL DYSAN OFFICE

CA:	Los Angeles (213) 907-1803 Orange County (714) 851-9462 Sacramento (916) 966-8037 San Francisco/Sunnyvale (408) 727-9552
DC:	Washington (703) 356-6441
GA:	Atlanta *(404) 952-0919
IL:	Chicago (312) 882-8176 (800) 323-5609
MA:	Boston (617) 273-5955 *(617) 229-2800
MI:	Detroit (313) 525-8240
MN:	Minneapolis *(612) 814-7199
MO:	St. Louis (314) 434-4011
NY:	New York (212) 687-7122
OH:	Cleveland (216) 333-3725
PA:	Pittsburgh (412) 261-0406 Philadelphia (609) 939-4762
TX:	Dallas/Ft. Worth *(817) 261-5312
WA:	Seattle (206) 455-4725

\*Includes OEM Sales

Dysan Diskettes are also available from all ComputerLand Stores, Sears Business Systems Centers, and many independent computer outlets nationwide.

For the location of the Dysan sales outlet nearest you, contact Dysan at: (408) 988-3472

Toll Free: (800) 538-8133  
Telex: 171551 DYSAN SNTA  
TWX: 910-338-2144



**Dysan**  
CORPORATION

Circle 173 on inquiry card.

# WHAT IS THE TRUE COST OF A DISKETTE?

If you said at least \$186.50\*, you're probably close.

Confused? It's simple. The minimum cost of a one-sided, single density 8" diskette equals the purchase price plus the cost of the time to fully load the data onto the disc\*. The adjacent diagram tells the story. As you can see, the purchase price of a diskette is a small fraction of the total cost of ownership. So why not pay a few cents more for the best diskette available?

That's where Dyan's quality comes in. Dyan diskettes and mini-diskettes are manufactured to the toughest quality standards in the industry. Every diskette is tested between the tracks as well as on the tracks to insure you 100% error-free recording over the entire disc surface. Dyan quality protects your investment of \$186.50.

You know how costly time and data losses can be should your "bargain" diskette be faulty. Every penny you think you save on the purchase of magnetic media could cost you dearly. Why take the risk when you can have Dyan?



**dy Jan** **Dyan**  
CORPORATION

Our Media Is Our Message

5201 Patrick Henry Drive  
Santa Clara, CA 95050

\*\$4.00 represents Dyan's suggested retail price for a one-sided, single density 8" diskette, packaged ten to a box. Minimum total cost of ownership = \$186.50

\*\$182.50 represents the cost of data loading (approximately 22 hours at 11,106 keystrokes/hour at a labor cost of \$8.23/hour), based on 1981 Data Entry Management Association (DEMA) National Averages.

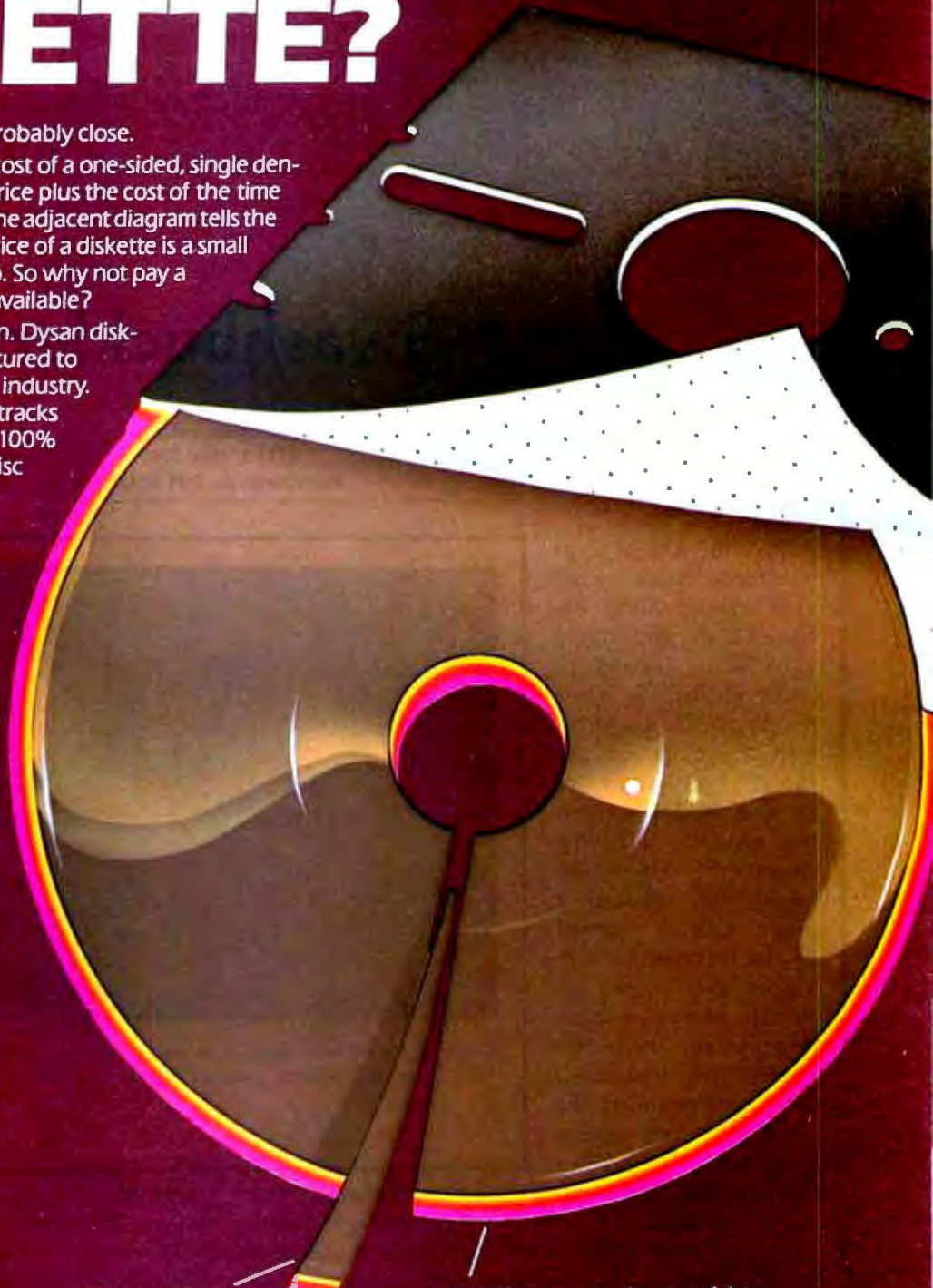

# BYTES ARCADE

## Swashbuckler

Scott Spangenberg  
RFD 1, Box 376  
Peterborough, NH 03458

Does the soul of Captain Blood reside within your Walter Mitty exterior? If so, you should know about Datamost's Swashbuckler, a game for the armchair swordsman yearning for the thrust and parry of flashing blades without the risk of annoying lacerations. The game takes place aboard a pirate galleon manned by the scurviest crew of villains ever to sail (or soil) the seven seas. Your swordsman, hereafter referred to as you, duels a series of pirates to the death. In this game, death is not a permanent

condition—the pirates are revived to fight again. You are revived twice, for a total of three lives per game.

To start your battles, insert the game disk and boot up your Apple II. After you see the title page, press the space bar to begin. As Swashbuckler opens, you are faced by an enormous, club-wielding giant. Your only hope is to parry off his blows until an opening appears.



Photo 1: As slain pirates lie in heaps on the deck, the swordsman prepares for another attack.

### Fencing Lesson

You use your left hand to move your swordsman, and your right to move his silver saber. The S key switches the direction you face. The A and D keys move you left and right, respectively, regardless of the direction you face.

Your right hand rests on a diamond pattern of keys composed of the I, J, K, L, and M keys. An I puts you in the high-parry position, which can help protect you from overhead blows. The M key places you in the low-parry position, which you use

to protect yourself from cuts to the leg and other low blows. The K returns you to the en garde position.

Moving left or right also returns you to the en garde position. J selects the thrust position, which I think of as a jab. Pressing L makes you lunge forward, sometimes right into your attacker's weapon. When you are hit and go down, your attackers move back a good bit and you are left in a heap in the center of the screen.

# MORE POWER TO YOUR APPLE

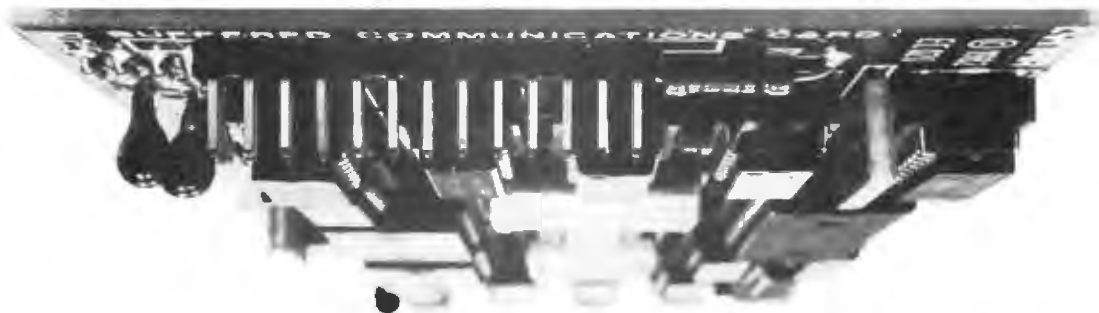

## BUFFERED COMMUNICATION CARD

Zynar's Buffered Communication Card (BCC) brings previously unavailable power and flexibility to the Apple II and III. Wherever the rate of data input is faster than the Apple can process, or where the Apple is restricted by a slow output medium, the BCC enables the Apple to operate effectively by leaving the major part of the I/O management to the BCC. To achieve this the BCC has its own 6502 microprocessor (the same as in the Apple) and memory (RAM) for buffering.

For example, data from an input device (graphics tablet; telephone line etc) can be accepted while the Apple is writing previous input to disk. Or the BCC can handle bulk transmission of data, freeing the Apple from operating at line speed. By using the BCC to buffer input, multiple devices can be controlled. One Apple, for example, could accept readings from several measuring devices.

EC020 is the standard card for Apple II and III. EC021, for the Apple II only, has an extra ROM. The code on this provides plug-compatibility with most other RS-232 peripheral cards, and can be used for automatic initialisation and control of communications. By customising it, the user can ensure an optimum interface to particular devices or resources.

### FEATURES

- Buffered, 2k of user-partitioned memory for optimum storage
- Programmable. Can be customised
- Dual speed operation
- RS-232-C. Standard interface
- Apple II and III. Compatible with both workstations
- 14 Baud rates. From 50-19200 Baud. Selectable by software or built-in switch
- Data Compression. Transparent compression of status words for efficient storage use
- Auto Shutdown. Closes transmitting modem when buffer is empty
- Real-Time Clock. Available to Apple. Intervals of 0.1 second upto 436 seconds.

OEM inquires welcome. Call or write for details now

# ZYNAR

SILICON TECHNOLOGY & COMPUTER SCIENCES

#### USA

Nestar Systems, Inc  
2585 East Bayshore Road  
Palo Alto California 94303  
Tel (415) 493-2223  
Telex 171420-NESTAR PLA

#### United Kingdom

Zynar Ltd  
122/3 High Street Uxbridge  
Middlesex UB8 1JT  
Tel (0895) 59831  
Telex 896607

#### Germany

Zynar Vertriebsgesellschaft mbH  
Gustav-Stresemann-Ring 12-16  
Postfach 4827, 6200 Wiesbaden  
Telefon (0 61 21) 37 30 51  
Telex 04 186 175 RANK D

Pressing any key will revive you. It takes a little practice to avoid standing up in the middle of someone's weapon and impaling yourself.

Before too long, when the giant would bring up his club for a blow, I was able to capitalize on the opening. When struck, the giant drops his jaw in surprise, lets go of his club, and slumps to the floor. In fact, each pirate reacts in a fairly realistic fashion to being stabbed or slashed.

You will meet up with several adversaries during the course of a game and, the farther along you get, the more you meet. (I encountered seven characters during my struggles.)

## The Game

You meet new adversaries in pairs, or actually waves of pairs. The first adversary in the pair will appear on the right-hand side of the screen. If you defeat him, his part-

## In Less Than 3 Minutes

Your IBM Model 50, 60, or 75  
Electronic Typewriter  
can be an RS232C PRINTER or TERMINAL



CALIFORNIA MICRO COMPUTER Models 5060 and 5061 can be installed easily and require NO modifications to the typewriter.

For additional information contact:

CALIFORNIA MICRO COMPUTER  
9323 Warbler Ave., Fountain Valley, CA.  
92708 (714) 968-0890

## At a Glance

**Name**  
Swashbuckler

**Type**  
Arcade-style game

**Manufacturer**  
Datamost  
9748 Cozycraft Ave.  
Chatsworth, CA 91311  
(213) 709-1202

**Price**  
\$34.95

**Author**  
Paul Stephenson

**Format**  
5¼-inch floppy disk

**Language**  
6502 machine language

**Computer**  
Apple II with 48K bytes of memory and one disk drive (DOS 3.2 or 3.3)

**Documentation**  
Two pages

**Audience**  
Game players

ner will immediately appear on the other side. That's your pair.

If you defeat the second character, you will have to contend with both of these adversaries at once—four, five, or nine times! That's a wave, and there are two waves for each scene after the first. In the first scene, there is only one wave, but you must defeat both members of the pair nine more times. The pair in the first wave of scene two will attack you six times, and the pairs in every wave afterward will attack five times.

You get one point for each pirate you defeat. The scene changes at 21, 43, 63, 83, and 103 points. I don't know how many scenes there are beyond that, because my high score is 112 points.

The pirates have trained pets that join in the attack against you at both regular and random intervals. You don't get any points for killing an attack pet, but doing so can help you get to the next scene. Sometimes you may

find yourself simultaneously fighting off two pirates and two attack pets, which are rats, cobras, spiders, and scorpions. As mentioned above, you are provided with a low parry to fend off their attacks. However, you can't move and keep the low-parry position at the same time because moving always returns you to en garde, so a certain amount of forethought must go into your movements.

In addition, the pirates you face change in some significant manner at each new scene and at 33, 53, 73, 93, and, probably, 113 points. The first two times, the change is to a new pair of adversaries. After you meet the first six pirates, the adversaries change in the way they are paired against you. The next change involves an even greater increase in speed, which forces you to treat supposedly familiar assailants with an entirely different set of tactics. At 83 points, some new characters begin to appear. The further along you go in the game, the faster and more aggressive the pirates are. After each wave, the pirates revive closer to the spot where you dropped them. When this starts happening, you should kick the body toward the edge of the screen before you meet the other attacker.

## Cast and Crew

After playing the game several times, I began to nickname each of the pirates (with apologies to Datamost). I call the first pirate Baldy Spikeclub. As long as Baldy keeps his club in front of him, he completely guards himself from your attacks, but he can't break through your guard as long as he stays in that position. When he raises the club, he is both dangerous and vulnerable. He's vulnerable because as soon as he moves his arms up or down you have an opening. Dangerous, because he can now kill you, especially if you thrust or lunge from too close in. He moves that club very, very fast even on the lowest level. When he appears again later in the game, he wields the club so fast that he's in a true rage and one of the toughest characters to defeat.

His partner, Ratface Daggeraxe, is relatively easy to dispatch once you learn not to let him and his ax get too close. He's usually so busy waving his weapon and looking ugly that he forgets to defend himself. Datamost should consider making this character fight more effectively, as he rapidly becomes a boring opponent.

The first character you meet in the second scene is Buccaneer. He's one of the two or three toughest characters I encountered, particularly on the higher levels where all the pirates move quickly. The first time you meet him, he swings his cutlass with alarming speed and can often reach much farther than you thought. Because he moves so fast, it can be very difficult finding an opening.



Ride the **wabash** express

<p><b>5 1/4" \$199*</b></p> <p>SINGLE SIDE SINGLE DENSITY WHUB RING</p> <p>SOFT, 10 OR 16 SECTORS</p> <p>100% CERTIFIED 2 YEAR WARRANTY</p>	<p><b>8" \$199*</b></p> <p>SINGLE SIDE SINGLE DENSITY</p> <p>SOFT OR 32 SECTORS</p> <p>100% CERTIFIED 2 YEAR WARRANTY</p>
<p><b>5 1/4" \$219*</b></p> <p>SINGLE SIDE DOUBLE DENSITY WHUB RING</p> <p>SOFT, 10 OR 16 SECTORS</p> <p>100% CERTIFIED 2 YEAR WARRANTY</p>	<p><b>8" \$249*</b></p> <p>SINGLE SIDE DOUBLE DENSITY</p> <p>SOFT OR 32 SECTORS</p> <p>100% CERTIFIED 2 YEAR WARRANTY</p>
<p><b>5 1/4" \$299*</b></p> <p>DOUBLE SIDE DOUBLE DENSITY WHUB RING</p> <p>SOFT, 10 OR 16 SECTORS</p> <p>100% CERTIFIED 2 YEAR WARRANTY</p>	<p><b>8" \$309*</b></p> <p>DOUBLE SIDE DOUBLE DENSITY</p> <p>SOFT OR 32 SECTORS</p> <p>100% CERTIFIED 2 YEAR WARRANTY</p>

\* • Minimum order 100 • For smaller quantities add 10%  
 • Packed 10 boxes of 10 diskettes with sleeves and labels  
 • Quantity discounts - 1,000 deduct 3%, 5,000 deduct 5%, 10,000 deduct 7%  
 • Add \$5.00 per case 5 1/4", \$7.00 per case 8"  
 For shipping and handling Continental U.S.A. U.P.S. ground.

<p>Buy 10 Diskettes 5 1/4" 8"</p> <p>OPUS ss-ss \$20 ss-ss \$21</p> <p>BASF ss-ss \$23 ss-ss \$24</p> <p>MAXWELL</p> <p>DYSAN</p> <p>TOO LOW TO QUOTE CALL</p>	<p><b>DISK DRIVE HEAD CLEANING KITS</b></p> <p>Prevent head crashes and ensure error free operation</p> <p>5 1/4" or 8"</p> <p><b>\$19.50</b></p>
<p><b>HARDHOLE DISK PROTECTORS</b></p> <p>Removes rings of tough mylar protect disk hole from damage</p> <p>Applicators</p> <p>Hardhole Rings (50)</p> <p>5 1/4" 8"</p> <p>\$3 \$4</p> <p>\$6 \$8</p>	<p><b>SFD C-10 CASSETTES . . 10/57</b></p> <p>(All cassettes include box and labels)</p> <p>Get 8 cassettes, C-10 Sonic, and Cassette 8 Library Album as illustrated, for only <b>\$8</b></p>
<p><b>LIBRARY CASES</b></p> <p>5 1/4" K10 10 \$2.99</p> <p>8" K10 10 \$2.49</p>	<p>5 1/4" or 8"</p> <p>Venet Storage Pages</p> <p>10/\$5</p>

• Written purchase orders accepted from government agencies and well rated firms at a 10% surcharge (wabash media only) for net 30 billing • International orders accepted with a 15.00 surcharge for handling, plus shipping charges. • C.O.D. requires a 10% deposit. • We accept Visa, MasterCard, Money Order, and Certificate checks. • Checks require bank clearances. • All shipments F.O.B. San Diego. • Minimum shipping and handling 2.00, minimum order 10.00. • California residents add 6% sales tax. • Prices and terms subject to change without notice. • All sales subject to availability, acceptance, and verification. • All sales are final. • Satisfaction guaranteed or full refund.

We also offer printer ribbons, printwheels, type elements, equipment covers, power consoles, paper supplies, storage and filing equipment furniture and many other accessories for word and data processing systems Write for our free catalog

Toll Free Order Only  
**800-854-1555**

For Information or California Orders  
**(714) 268-3537**

**ABM PRODUCTS**

8868 CLAIREMONT MESA BLVD.  
 SAN DIEGO, CALIFORNIA 92123





# BYTE'S ARCADE

The cobra can really move fast! This lovely pet is just as easy to dispatch as the rat, if you are quick, but it's apt to surprise you. The cobra first appears in scene one, but he can appear at odd moments throughout the game. Its bite is deadly.

The other two creatures are the spider and scorpion. Their graphics are especially well done. Both first appear in scene two and randomly throughout the game thereafter. Your defense here is also the low parry.

## Game Strategy

A player can do fairly well in the lower levels of this game by attacking whenever possible. Proceeding further requires a certain amount of strategy. Never lunge when a simple thrust will do: you are likely to lunge right into your opponent's weapon. Try to give yourself as much fighting room as possible. Remember to meet each pirate on his side of the screen, because this keeps you from get-

ting caught between two enemies with nowhere to retreat. Also remember to kick the bodies out of the way to create fighting room or you will find pirates stabbing you in the back the moment they are revived. When you cut down the second pirate of a pair, you should stay close to the place where he will be revived so that you can hold out your sword and impale him again when he stands up. Finally, watch out for those nasty creatures on the floor. If an attack pet comes toward your back while you are busy with a fight, you should deal with it first and then return to the fight.

I think that most arcade-game fans will find Swash-buckler an enjoyable experience. The title page and some of the scenes are a little sloppier than you might expect in a \$35 game, but the animation is a real winner. The need to plan your moves and to use strategy elevates Swash-buckler well above the run-of-the-mill arcade game. I'm not finished playing yet. ■

## DISCOUNT PRINTER RIBBONS

Brand New, Top Quality, Exact Replacement Ribbons & Cartridges. These Ribbons Produce Super Jet Black Impressions and Ultra Reliable Print Life. They Are Delivered to Your Door Promptly for Much Less Than Most Retail Stores

**★SPECIAL! BUY 10 and GET ONE FREE!**

**40% OFF!!**  
OR MORE!

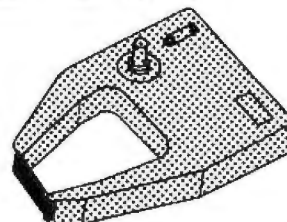

YOUR PRINTER	PACK SIZE	RETAIL LIST**	YOUR WHOLESALE PRICE		SIZE	COMMENTS	CAT. ORDER #
ANADIX 9000 Series	1 pk	14.00 ea	14.00	11.40 ea	500	Nylon Jet Bk	C-777
CENTRONICS 700-703, 737, 779	3 pk	18.95/3 pk	11.95/3 pk	13.99 ea	563" x 45'	Nylon Jet Bk	C-700
CENTRONICS 100, 101A, 102, 103, 300, 301, 306, 308, 330, 358, 398, 500, 501, 503, 508, 588, 620, 820	3/pk	26.33/3 pk	17.95/3 pk	15.95 ea	1' x 108'	Nylon Jet Bk 5 ml High Speed	C-100
CENTRONICS 704-705	1/pk	16.95 ea	13.95/Giant Cartr	11.95 ea	5'18" x 210'	Giant Cartr	C-7045
DEC 1/2 x 40YD	3/pk	17.77/3 pk	12.95/3 pk	14.32 ea	1'2" x 120'	Double Spools	R-800
DEC 1/2 x 60YD	3/pk	20.12/3 pk	14.25/3 pk	14.75 ea	1'2" x 180'	Double Spools	R-644
DIABLO HYTYPE II (M/S BLK) HI YIELD FITS JO PRINTERS!	1/pk	9.31 ea	6.87 ea	6.87 ea	5'18" x 300,000 plus emp	High Yield	C-511
EPSON MX70-80	1 pk	16.00 ea	16.00 ea	11.95 ea	500' x 60'	Nylon Jet Bk	C-522
IBM - "SILVER DOLLAR" Sys 34, Sys 32 MDLA, Senes IMDL4974, 5258, 3287, 3770, 3771-3774, 4874, 5100, 5103, 5110, 5228, 5258, 5320MDLA IBM - HARMONICA 1/2" SERIES I MOD 4973/II, 3200, 3289, MOD 2	5/pk	5.80 ea	14.90/5 pk	12.98 ea	9'18" x 30'	Nylon Jet Bk	R-300
NEC SPINWRITER DUME (FITS 80 PRINTER MODES)	4/pk	23.40/3 cartr	23.60/4 pk rb reload	15.90 ea	1'2" x 51'	Nylon/Es Long Life	R-400
RADIO SHACK DAISY WHEEL II	3/pk	18.00/3 pk	13.95/3 pk	14.65 ea	1'4" x 310'	Multistrike Film	C-525
RADIO SHACK LPRI, LPV	1 pk	24.95 3pk	8.25	18.25 ea	250	Nylon Multistrike	C-789
RADIO SHACK LPRI, LPV	one pk	13.95/cart	8.95/Reload rib* only	18.95 ea	500" x 45'	Nylon Incl Instr	R-T3
TELETYPE MOD 33, 28, 35, 37, 38, 88	3/pk	18.95/3 pk	11.95/3 pk	13.98 ea	563" x 45'	Nylon Jet Bk	C-700
WANG M/S, 5541W, WC, 5581, WD, 8581W, 2281W	10/pk	2.40 ea	13.90/10 pk	11.39 ea	1'2" x 36'	Nylon Jet Bk	R-450
	1/pk	6.85 ea	5.95 ea	5.95 ea	5'18" x 393'	Multistrike Film	C-550

### TERMS:

MINIMUM PURCHASE - \$20  
PAYMENT BY: C.O.D. (UPS), CHECK, MASTER CARD, OR VISA CHARGE CARD.

### VOLUME DISCOUNTS:

20 - 50 PACKS 10%  
51 - 100 PACKS 15%  
\*UNDER \$20, ADD \$5 HANDLING.  
\*\*APPROX. RETAIL. PRICE VARIES.

**ANCIE LABORATORIES**  
5200-J Philadelphia Way 301-345-6000 (Wash. D.C. Local)  
Lanham, Maryland 20706 301-792-2060 (Baltto. MD Local)  
**800-638-0987 (National)**

NAME _____	QTY _____	CAT.# _____	AMT. _____	<input type="checkbox"/> Check Enclosed <input type="checkbox"/> C.O.D. <input type="checkbox"/> VISA <input type="checkbox"/> MASTER CHARGE ACCT. # _____ EXP. DATE _____ MIN. ORDER \$20 PRICES SUBJECT TO CHANGE
ADDRESS _____	_____	_____	_____	
CITY _____ STATE _____ ZIP _____	_____	_____	_____	
ANCIE Laboratories 5200-J Philadelphia Way Lanham, Maryland 20706	301-345-6000 (Wash. D.C. Local) 301-792-2060 (Baltto. MD Local) 800-638-0987 (National)	TOTAL _____	_____	

# LOWER COME HIGH



I'm Nicholas van Horn the Third, but you can call me Old Nick.

I've just made a pact with the Discount Software folks and we've come up with a plan that is positively diabolical:

To get your business, we're going to sell you any of the software you need at the lowest prices in the industry.

I'm not just blowin' smoke—I'll back up that claim with the exclusive *Old Nick's Price Protection Guarantee*:

"I'll match any advertised price on any item you want to buy from us. And if—Heaven forbid—you find a lower price on what you bought within 30 days, just show me the ad and I'll refund the difference."

We won't leave you in limbo, either—if you've got any questions about the software after you get it, just call our Hot Line and get the answers you need from our fiendishly clever support staff.

All in all, unless you've got money to burn, you'll be a lot better off buying all your software from me.

Because while I may be small and horny, I'll work my tail off to make sure that you get your software for less than ever before. Now doesn't that light your fire?

**GOT A QUESTION?  
CALL OUR HOT LINE: 213-837-5141.**

Tell 'em Old Nick made you do it.

# PRICES, HELL OR WATER.

CP/M		Multi Plan Manager Series		ACCOUNTING PLUS		Micro B+		16-BIT SOFTWARE	
DISK WITH MANUAL / MANUAL ONLY		Call	Call	1 Module	\$385/\$na	Raid	\$229/\$20	<b>WORD PROCESSING</b>	
<b>ARTIFICIAL INTELLIGENCE*</b>		Call	Call	4 Modules	\$1255/\$na	String/80	\$ 84/\$20	<b>IBM PC</b>	
Medical (PAS-3)	\$849/\$40	Text/Writer III	\$111/\$25	All 8	\$4500/\$na	String/80 (source)	\$279/\$na	Wordstar	\$289
Dental (PAS-3)	\$849/\$40	DateBook II	\$269/\$25	<b>TCS*</b>		ISIS CP/M Utility	\$199/\$50	Lynx	\$199/\$20
<b>ASYST DESIGN*/FRONTIER</b>		Milestone	\$269/\$30	All 4	\$ 79/\$25	CP/M Power	\$ 95/\$na	Easywriter	\$314
Prof Time Accounting	\$549/\$40	<b>OSBORNE*</b>		Inventory	\$269/\$99	Mathe Magic	\$ 75/\$na	Easyspeller	\$159
General Subroutine	\$269/\$40	General Ledger	\$ 59/\$20	Compiled each	\$ 99/\$25	CIS COBOL	\$785/\$na	Select Superspell	\$535
Application Utilities	\$439/\$4C	Acct Rec/ Acct Pay	\$ 59/\$20	<b>UNICORN*</b>		ZIP	\$129/\$12	Write On	\$116
<b>DIGITAL RESEARCH*</b>		Payroll w/Cost	\$ 59/\$20	Mince	\$149/\$25	Real Estate Analysis	\$116/\$na	Spellguard	
CP/M 2.2		All 3 + CBASIC-2	\$129/\$60	Scribble	\$249/\$50			(also available for 8" 8086 systems)	\$229
NorthStar	\$149/\$25	Enhanced Osborne	\$199/\$75	The Final Word	\$270/\$25			SP Law	
TRS-80 Model II (P+T)	\$159/\$35	(Includes CBASIC)	\$269/\$60	<b>WHITESMITHS*</b>				(for Spellguard)	\$115
Micropolis	\$175/\$25	<b>PEACHTREE*</b>		C Compiler	\$600/\$30			Textwriter III	\$189
CP/M-Intel MDS	\$135	General Ledger	\$399/\$40	Pascal (incl. "C")	\$850/\$45			Spellbinder	\$349
PL/1-80	\$459/\$35	Acct Receivable	\$399/\$40	<b>"PASCAL"</b>				Final Word	\$270
BT-80	\$179/\$30	Acct Payable	\$399/\$40	Pascal/MT + Pkg	\$449/\$30			<b>LANGUAGE UTILITIES</b>	
MAC	\$ 85/\$15	Payroll	\$399/\$40	Compiler	\$315			<b>IBM PC</b>	
RMAC	\$179/\$25	Inventory	\$399/\$40	Sp Prog	\$175			Crossalk	\$174
Std	\$ 65/\$15	Surveyor	\$399/\$40	Pascal/Z	\$349/\$30			BSTAM	\$149
Z-Std	\$ 90/\$15	Property Mgt	\$799/\$40	Pascal/UCSD 4.0	\$670/\$50			BSTMS	\$149
Tex	\$ 90/\$15	CPA Client Write-up	\$799/\$40	Pascal/M	\$355/\$20			<b>8" 16-BIT SYSTEMS</b>	
DeSpool	\$ 49/\$10	P8 Version	Add \$129	Tiny Pascal	\$ 78/\$15			Pascal MT + /86 SSP	\$429
CB-80	\$459/\$35	MagCalc	\$269/\$25	<b>"DATA BASE"</b>				CBasic 86	\$294
CBasic-2	\$119/\$20	✓ Peach Pak* Series 4	\$1195/\$na	FMS-80	\$894/\$45			Pascal M/86	\$445
Linx-80	\$ 90/\$10	Other	less 10%	Condor II	\$899/\$50			Act 86	\$157
<b>FOX &amp; GELLER</b>				FMS-81	\$445/\$na			Trans 86	\$115
✓ Quickscreen	\$135/\$na	<b>STAR COMPUTER SYSTEMS</b>		<b>"WORD PROCESSING"</b>				XLT 86	\$135
✓ Quickcode	\$285/\$na	G/L, A/R, A/P, Pay	\$ 359	WordSearch	\$179/\$50			<b>16-BIT 8" AND DISPLAYWRITER</b>	
✓ dutil	\$ 65/\$na	All 4	\$129	SpellGuard	\$229/\$25			CP/M 86	\$294
<b>MICRO-AP*</b>		Legal Time Billing	\$ 849	VTS/80	\$259/\$65			MP/M 86	\$585
S-Basic	\$269/\$25	Property Mngmt	\$ 849	Peachtot	\$289/\$45			<b>OTHERS</b>	
Selector IV	\$295/\$35	<b>STRUCTURED SYSTEMS*</b>		Magic Spell	\$269/\$25			<b>IBM PC</b>	
Selector V	\$495/\$50	Business Packages		Spell Binder	\$349/\$45			SuperCalc	\$269
<b>MICRO DATA BASE SYSTEMS*</b>		Call for Price		Select	\$495/\$na			VisiCalc	\$219
HDBS	\$269/\$35	<b>SORCIM*</b>		The Word	\$ 65/\$na			Easyfiller	\$359
MDBS	\$795/\$40	SuperCalc	\$269/\$na	✓ The Word Plus	\$145/\$na			Mailmagic	\$ 89
DRS or QRS or RTL	\$269/\$10	Trans 86	\$115	✓ Palantier-I (WP)	\$385/\$na			CP/M Power	\$ 85
MDBS PKG	\$1999/\$60	Act	\$157	<b>"COMMUNICATIONS"</b>				Condor 21	\$285/\$35
<b>MICROPRO*</b>		<b>SUPERSOFT*</b>		✓ Ascum	\$149/\$15			Condor 22	\$535/\$35
WordStar	\$289/\$60	Ada	\$270/\$na	✓ BSTAM	\$149/\$na			Condor 23	\$895/\$35
Customization Notes	\$449/\$na	Diagnostic I	\$ 49/\$20	✓ BSTMS	\$149/\$na			Condor 20Q	\$175/\$na
Mail-Merge	\$ 99/\$25	Diagnostic II	\$ 84/\$20	✓ Crosstalk	\$139/\$na			Condor 20R	\$285/\$na
WordStar/Mail-Merge	\$369/\$85	Disk Doctor	\$ 89/\$20	✓ Move-it	\$ 89/\$na			Statpak	\$449/\$40
DataStar	\$249/\$60	Fortn (8080 or Z80)	\$149/\$25	<b>"OTHER GOODIES"</b>				Optimizer	\$174/\$na
WordMaster	\$119/\$40	Fortran	\$219/\$30	Micro Plan	\$419/\$na			Desktop Plan II	\$219
SuperSort I	\$189/\$40	Fortran w/Ratfor	\$289/\$35	Plan 80	\$269/\$30			Desktop Plan III	\$259
Spell Star	\$175/\$40	C Compiler	\$225/\$20	Target (Interchange)	\$125/\$30			Visidex	\$219
CalcStar	\$259/\$na	Star Edit	\$189/\$30	Target (Planner)	\$189/\$30			Visitrend	\$259
<b>MICROSOFT*</b>		Scratch Pad	\$174/\$15	Target (Task)	\$299/\$30			TCS G/L, A/R, A/P	
Basic-80	\$298	StatsGraph	\$174/\$15	Plannercalc	\$ 50			Pay. Inventory	
Basic Compiler	\$329	Analiza II	\$ 45/\$na	Tiny "C"	\$ 89/\$50			(requires 128K RAM) each	\$129
Fortran-80	\$349	Dataview	\$174/\$15	Tiny C Compiler	\$229/\$50			Entire Package	\$450
Cobol-80	\$589	Disk Edit	\$ 89/\$15	Nevada Cobol	\$179/\$25			Many others available for use with the "Baby Blue Board"	
M-Sort	\$175	Encode/Decode II	\$ 84/\$15	MicroStat	\$224/\$25			<b>8" 16-BIT SOFTWARE</b>	
Macro-80	\$144	Optimizer	\$174/\$15	Vedit	\$130/\$15			SuperCalc	\$269
Edit-80	\$ 84	Super M List	\$ 68/\$15	MiniModel	\$449/\$50			CP/M Power	\$ 85
MuSimp/MuMath	\$224	Term II	\$179/\$15	StatPak	\$449/\$40				
MuLisp-80	\$174	Zap Z-8000	\$450/\$15						
		Utilities I	\$ 54/\$na						
		Utilities II	\$ 54/\$na						

ORDERS ONLY—CALL TOLL FREE—VISA—MASTERCHARGE  
 1-800-854-2003 ext. 823 • Call. 1-800-522-1500 ext. 823  
 Outside Continental U.S.—add \$10 plus Air Parcel Post • Add \$3.50 postage and handling per each item • California residents add 6% sales tax • Allow 2 weeks on checks, C.O.D. \$3.00 extra • Prices subject to change without notice • All items subject to availability • ®—Mfr. trademark—Blue Label \$3.00 additional per item.



**THE DISCOUNT SOFTWARE GROUP**  
 6520 Selma Ave., Suite 309 • Los Angeles, CA 90028  
 • (213) 837-5141 • In't TELEX 499-0446 DISCSOFT LSA  
 • USA TELEX 194-834 (Attn: 499-0446)  
 • TWX 910-321-3597 (Attn: 499-0446)

THE ULTIMATE SOFTWARE PLAN

Circle 166 on inquiry card.

## Zero Gravity Pinball

Mark Friedman  
23 Forge Dr.  
Nashua, NH 03069

Thoughts of pinball bring back fond memories of pizza parlors and pool halls, but no pizza parlor or pool hall yet built has a game anything like Zero Gravity Pinball. In fact, you won't be able to find a pizza-parlor version of Zero Gravity Pinball until orbiting space stations become commonplace. The game was written for the Apple II by Don Fudge and is marketed by Avant-Garde Creations.

True to the traditions of its earthbound predecessors, Zero Gravity Pinball challenges you to score as many points as you can using flippers to keep the ball in play. Without gravity's influence, the ball moves in a straight line until it hits an object or moves off the playing area. Furthermore, instead of the traditional two flippers, you have 10, five on each side of the playing area.

### Getting Started

The instructions for playing the game are printed on the back of the package wrapper. Although the instruc-

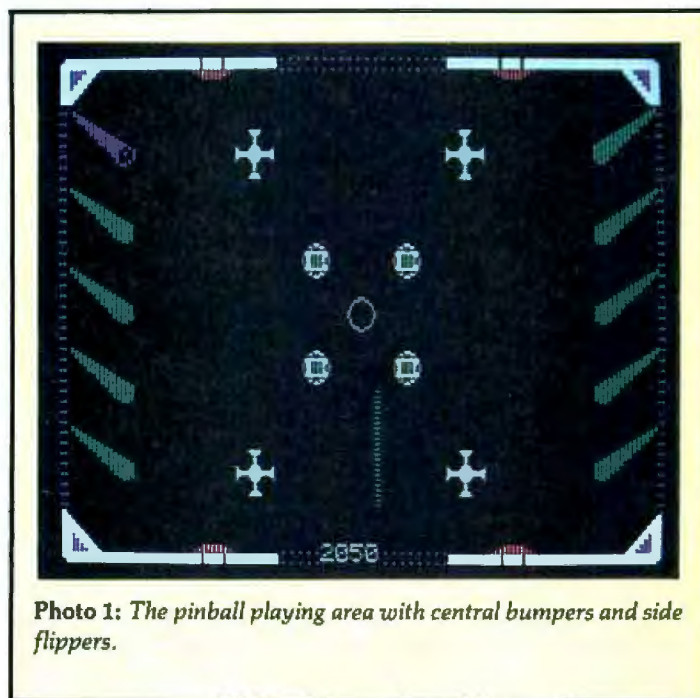

Photo 1: The pinball playing area with central bumpers and side flippers.

tions are otherwise quite detailed, I found one serious omission: how to start the game. Fortunately, start-up is a simple process: insert the disk into drive 1 and boot up normally.

After the program boots up, you'll see the title page. Press any key to continue and the credits' screen will appear. Next, you are asked if you would like instructions. The on-screen instructions repeat the information from the printed documentation. It now takes about 40 seconds for the game to load.

Next comes your most important decision of the next couple of hours: which level of difficulty do you want? The levels range from 1 (slow) to 5 (masochists only). Another brief delay follows, during which you should grab game paddle 0, because the first ball is automatically released.

### The Layout

As you view the playing area (see photo 1), you'll notice some of the unique features of Zero Gravity Pin-

# New books from DIGITAL PRESS

## Learning with Computers Bork

A comprehensive overview for using the computer as a teaching device to build a more responsive learning environment. 1981, hardbound, 286 pages, \$28.00

## Engineering a Compiler: VAX-11 Code Generation and Optimization

Anklam, Cutler, Heinen, and MacLaren

Step-by-step descriptions and practical experiences of the programming team developing the PL/I General Purpose subset compiler for the VAX machine. 1982, hardbound, est. 270 pages, \$24.00

## Office Automation: A Survey of Tools and Technology

Barcomb

The first practical introduc-

tion on office automation functions, equipment, and techniques. 1981, 241 pages, hardbound: \$24.00, paperbound: \$15.00

## Technical Aspects of Data Communication, Second Edition

McNamara

A practical up-to-the-minute approach to the nuts-and-bolts problems and solutions in configuring communications systems. 1982, hardbound, 330 pages, \$32.00

## The Theory and Practice of Reliable System Design

Siewiorek and Swarz

Shows how to combine economics with design and cost modeling with reliability modeling in hardware system design. 1981, hardbound, 772 pages, \$55.00



## Also available from Digital Press

### Computer Programming and Architecture: The VAX-11

Levy and Eckhouse. 1980, hardbound, 407 pages, \$28.00

### Engineering Intelligent Systems: Concepts, Theory, and Applications

Glorioso and Colon Osorio. 1980, hardbound, 472 pages, \$29.00

### Computer Engineering: A DEC View of Hardware Systems Design

Bell, Mudge, and McNamara. 1978, hardbound, 585 pages, \$28.00

### TEX and METAFONT, New Directions in Typesetting

Knuth (co-published with

American Mathematical Society). 1979, paperbound, 355 pages, \$12.00

### From ENIAC to UNIVAC: An Appraisal of the Eckert-Mauchly Computers

Stern. 1981, hardbound, 286 pages, \$25.00

### Project Whirlwind: The History of a Pioneer Computer

Redmond and Smith. 1980, hardbound, 280 pages, \$25.00

### Early British Computers

Lavington (co-published with Manchester University Press). 1980, paperbound, 146 pages, \$9.00

### Introduction to DECSYSTEM-20: Assembly Language Programming

Gorin. 1981, paperbound, 576 pages, \$39.00

### Data Processing Technology and Economics, Second Edition

Phister (co-published with Santa Monica Publishing Company). 1979, 736 pages, hardbound: \$45.00, paperbound: \$30.00

VAX Software Handbook  
1982, paperbound, 529 pages,  
\$15.00

### Distributed Systems Handbook

1978, paperbound, 276 pages,  
\$15.00

Introduction to BASIC  
1978, paperbound, 227 pages,  
\$10.00

### 101 BASIC Computer Games

1975, paperbound, 249 pages,  
\$10.00

## Coming soon from Digital Press

### Nine Steps for Effective EDP Loss Control

Computerizing Your Small  
Business

### Strategic Planning for Campus Computing: Ten Creative Approaches

## Ordering Information

Postage and handling free when order is prepaid. Ten percent discount when ordering two or more books. Make check payable to Digital Equipment Corporation. Check or charge card required on all orders under \$50.

QUANTITY	TITLE	PRICE*

Mail to: Digital Press Order Fulfillment  
Digital Equipment Corporation  
12-A Esquire Road  
Billerica, MA 01862

Subtotal \_\_\_\_\_

Discount \_\_\_\_\_

Sales Tax \_\_\_\_\_

Total \_\_\_\_\_

\*All prices quoted are U.S. only. For prices outside the U.S., contact your nearest office of Digital Equipment Corporation, Educational Services. Prices are subject to change without notice.

Circle 163 on inquiry card.

### TOLL-FREE ORDER NUMBER

To order books by MasterCard or VISA, call the Digital Press toll-free number. 1 800-343-8322 or 8321. In Massachusetts, call (617)663-4124. Phone lines are open from 8:00 a.m. to 4:00 p.m., Eastern time.

Name \_\_\_\_\_ Company/School \_\_\_\_\_

Address \_\_\_\_\_

City \_\_\_\_\_ State \_\_\_\_\_ Zip \_\_\_\_\_

### METHOD OF PAYMENT

Check included.  MasterCard  VISA  Purchase Order (attach P.O.)

Charge Card Acc't No \_\_\_\_\_ Expiration Date \_\_\_\_\_

Authorized Signature \_\_\_\_\_ Telephone \_\_\_\_\_ BYT-9/82

**digital**

We change the way  
the world thinks.

## At a Glance

**Name**

Zero Gravity Pinball

**Type**

Arcade-style game

**Manufacturer**

Avant-Garde Creations  
POB 30160  
Eugene, OR 97403  
(503) 345-3043

**Price**

\$29.95

**Author**

Don Fudge

**Format**

5¼-inch floppy disk

**Language**

6502 assembly language

**Computer**

Apple II with 48K bytes of memory. Applesoft in ROM or Language Card, one disk drive (DOS 3.2 or 3.3), game paddle 0

**Documentation**

One-page card

**Audience**

Arcade enthusiasts of all ages

ball. The playing area is square, with gaps (indicated by dotted lines) on all four sides. The game begins when the ball appears from the central bumper and starts its journey. The ball can also disappear there, as this bumper occasionally turns into a hole, but there's not much you can do about that.

Before turning to the flippers on each side of the screen, a word about those openings at top and bottom is in order. To keep from losing the ball in the lower opening, you must press the space bar before the ball enters the void; if you're too slow, the ball explodes. To guard the upper opening, press any key *except* the space bar. These protective "force fields" have a limited range and have no effect unless the ball is about to exit from the top or bottom of the screen.

### The Flippers

The primary challenge of Zero Gravity Pinball is that you need three hands to play, because, while worrying about which key to hit next, you're busy twisting away at

the game paddle to control the flippers. Although there are 10 flippers on the screen, only one is in play at any given time. To select a flipper, turn the game paddle until the desired flipper changes color from green to red. Then press the paddle button to flip the ball back into play. The flippers, like the upper and lower shields, are active only when the ball is nearby.

The flippers are not solid, but rather are "force fields." As a result, the ball will go through a nonselected flipper, causing it to vanish until you select it, or until the next ball is released.

At this point, you're busy paddle twisting, button pushing, and key pressing, so a word of warning may be appropriate. Every once in a while a flipper may be red, but in fact be a useless "bogey," or even worse, a white "superbogey": there, but not there. In either case, just turn the paddle knob back and forth to restore normal functioning. Occasionally, the top two flippers will act as if they were solid even though they've not been selected.

### Scoring

Once you've accumulated 50,000 or more points with the five balls you are allotted, it's time to move up to the next level of difficulty, because a score of more than 64,000 points ends the game. While I'm reluctant to reveal my top score, let me assure you that it was nowhere near that level. If you have a joystick and a steadier hand than mine, flipper selection should be easier and faster, and your scores higher.

While the screen layout is relatively simple, particularly compared to some of its earth-based predecessors, the quality of the graphics and animation is excellent, and its color and sound are good. Even at level 5, the ball's movement was quite smooth—though moving too fast to provide much opportunity to keep it within the playing area. In fact, the press release accompanying the review copy indicated that anyone able to hit the ball more than twice at level 5 was worthy of a plaque.

### Conclusions

While it has some similarities with other pinball games, Zero Gravity Pinball takes much longer to master than the more familiar two- or four-flipper games.

The five levels of difficulty allow almost anyone to enjoy the game, while providing lots of challenge for the most accomplished player.

Zero Gravity Pinball is an original and unique game that makes excellent use of the Apple's graphics capabilities. It may be one of the best tests of eye-hand coordination around, as well as being a lot of fun. ■

**MD-10**  
 10 MEGABYTE SUBSYSTEM  
**\$2695**  
 SUGGESTED  
 RETAIL

**MD-20**  
 20 MEGABYTE SUBSYSTEM  
**\$3595**  
 SUGGESTED  
 RETAIL

**10 & 20 MEGABYTE (FORMATTED)  
 5 1/4" WINCHESTER SUBSYSTEMS**

For Z-80 based micros which utilize the CP/M operating system . . .

- |         |                   |                       |           |
|---------|-------------------|-----------------------|-----------|
| CCS     | APPLE (with CP/M) | ZENITH/HEATH          | NORTHSTAR |
| GODBOUT | XEROX 820         | ANY Z-80 S-100 SYSTEM |           |
| ALSPA   | TRS-80 MOD II     |                       |           |
| OSBORNE |                   |                       |           |

All units are delivered completely assembled and tested, with drive, controller, case, power supply, cabling, Z-80 interface and all requisite software. A few features:

**THE Z-80 INTERFACE:**

- ▶ Supports vectored interrupts
- ▶ Plugs directly into the Z-80 socket on the host CPU (requires no special buss)
- ▶ Allows for DMA operation (if you already have a DMA system)
- ▶ Supports MP/M, OASIS and other operating systems (with additional software)

**OUR SOFTWARE:**

- ▶ Written in Z-80 assembly language
- ▶ Automatically configures virtually any existing version 2.x CP/M to the hard disk subsystem
- ▶ Includes SOURCE CODE
- ▶ Requires less than 2k of overhead memory
- ▶ Enables the user to read or write a 64k file in less than four seconds

**FULL SIX-MONTH WARRANTY!**

Dealer inquiries are more than welcome

CP/M and MP/M are registered trademarks of Digital Research; OASIS is a proprietary product of Phase One Systems, Inc.; Z-80 is a trademark of Zilog.

Circle 290 on Inquiry card.

**MEDIA DISTRIBUTING**  
**(408) 438-5454**  
 4444 SCOTTS VALLEY DR.  
 SCOTTS VALLEY, CA 95066  
 TERMS: Cashiers Check,  
 VISA, M/C, COD  
 Shipping charges  
 added to all  
 orders

# YOUR COMPUTER HEADQUARTERS

**apple®**

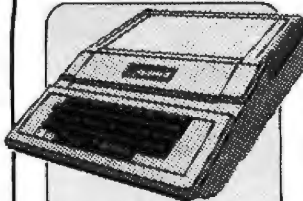

**New! New! New!**  
**APPLE II plus 48K**  
 Apple Disc Drive II  
 with interface DOS 3.3,  
 Apple III 12" Monitor and the  
 Apple Monitor Stand

All for Only **\$1799<sup>95</sup>**

**BONUS! Apple Writer II**  
 Reg. 1149<sup>95</sup> Special **\$49<sup>00</sup>**  
 with purchase of  
 this fabulous package

**WORD PROCESSOR SYSTEM**

Apple II plus 48K  
 Apple Disc Dr II  
 with interface DOS 3.3  
 Apple III monitor  
 Okidata Microline 80 Printer  
 Printer Cable w/Interface  
 Screen Writer II

**\$2325<sup>00</sup>**

**APPLE**  
 Available in 220 Volts  
 at Additional Cost

**ACCESSORIES FOR APPLE**

- Videx Videoterm . . . \$259<sup>00</sup>
- Keyboard Enhancer II . . . \$119<sup>00</sup>
- Microsoft Z-80 CP/M Card \$279<sup>00</sup>
- Microsoft 16K Ram Card \$139<sup>00</sup>
- Saturn 32K Ram Card \$189<sup>00</sup>
- Saturn 64K Ram Card \$379<sup>00</sup>
- Saturn 128K Ram Card \$519<sup>00</sup>
- TKC Numeric Keypad \$134<sup>00</sup>
- ABT Numeric Keypad \$109<sup>00</sup>
- Thunderclock Plus \$119<sup>00</sup>
- X-10 Interface Option . . . \$42<sup>00</sup>
- Hayes Micromodem II \$289<sup>00</sup>
- Hayes Smartmodem \$239<sup>00</sup>
- Kensington System Saver Fan \$74<sup>00</sup>
- Micro Buffer II 16K \$214<sup>00</sup>
- Micro Buffer II 32K \$249<sup>00</sup>

Micro Buffer II Available in Parallel or Serial  
 Please specify when ordering  
 Microbuffer/EPSON 16K  
 Parallel \$134<sup>00</sup>  
 Microbuffer/EPSON 8K  
 Serial \$134<sup>00</sup>  
 Grappler Interface \$139<sup>00</sup>

**SOFTWARE /APPLE WORD PROCESSORS**

- Format II (Macintosh) \$279<sup>00</sup>
- Easywriter Pro \$139<sup>00</sup>
- Easywriter Pro \$139<sup>00</sup>
- Screenwriter II \$104<sup>00</sup>
- Word Handler II \$149<sup>00</sup>
- Magic Window \$84<sup>00</sup>
- Select CP/M Call \$99<sup>00</sup>
- Sensible Speller \$99<sup>00</sup>

**SPECIAL! MICRO PRO-WORD STAR**  
 • Word Star All 3 for Only  
 • Spell Star **\$299<sup>00</sup>**  
 • Mail Merge  
LIMITED TIME

**U-S-C-I MICRO-S-C-I**

**APPLE COMPATIBLE DISC DRIVES**  
 A:2 Disc Drive with Controller \$469<sup>00</sup>  
 without Controller \$369<sup>00</sup>

**SMITH-CORONA TP-1 LETTER QUALITY ELECTRONIC TEXT PRINTER**



Now Only **\$679<sup>00</sup>**  
 • Low cost daisy wheel printer  
 • Microprocessor electronics  
 • Serial or parallel interfaces  
 • 120 words per minute  
**CABLES FOR MOST PERSONAL COMPUTERS IN STOCK!**

**ACCESSORIES FOR APPLE (continued)**

- DATA BASE**
- DB Master Vers 3 \$179<sup>00</sup>
  - Utilities Pack I or II \$179<sup>00</sup>
  - Ashton Tate dBase II \$499<sup>00</sup>
  - VisiFile \$189<sup>00</sup>
  - VisiIndex \$189<sup>00</sup>
  - Data Factory 5.0 \$229<sup>00</sup>
  - The General Manager \$119<sup>00</sup>
  - PFS New \$97<sup>00</sup>
  - PFS Report \$76<sup>00</sup>

- FINANCIAL MODELING/PLANNING**
- Visicalc \$189<sup>00</sup>
  - Visitrend/Visiplot \$229<sup>00</sup>
  - Target Planner/Calc CP/M \$40<sup>00</sup>
  - Supercalc CP/M \$219<sup>00</sup>

- ACCOUNTING**
- Home Accountant \$80<sup>00</sup>
  - Accounting Plus Call
  - Brodebund Payroll \$299<sup>00</sup>
  - Easy III for Apple III \$499<sup>00</sup>

- GRAPHICS**
- Apple World, 3-D Super Graphics
  - GPS (Graph Proc. System) Pro \$79<sup>00</sup>
  - Complete Graphics
  - System (Penguin) \$54<sup>00</sup>
  - Executive Briefing System \$159<sup>00</sup>
  - Alpha Bytes Font Disk \$22<sup>00</sup>
  - Alpha Bytes Decorative Disc \$22<sup>00</sup>

- COMMUNICATION**
- Data Capture 4.0 \$49<sup>00</sup>
  - Data Capture 2.0 (Videx) \$69<sup>00</sup>
  - Visiterm \$79<sup>00</sup>
  - Context Connector \$139<sup>00</sup>
  - Trendset w/Source Account \$89<sup>00</sup>

**FRANKLIN**



**ACE 100 Personal Computer**  
 A professional personal computer that is hardware/software compatible with the Apple II® & includes many features not found on the Apple II®.

**FEATURES:**  
 Apple® compatible, 64K of RAM memory, upper & lower case, typewriter-style keyboard, 12-key numeric pad, alpha lock shift key, Visicalc friendly, 50-watt power supply, built-in fan.  
**Call for Low Price!**

**SPECIAL OFFER!**

Buy a Microsoft Z-80 CP/M card for \$279.95, a Videx Videoterm 80 col. board for \$259.95 and a CP/M Users' Guide for \$10.00, then save \$100.00 on purchase of the 16K Microsoft RAM Card  
 Reg. \$159.95  
 Now Only **\$59<sup>95</sup>**  
 Plus-get a FREE Videx Soft Switch (\$30 Value!).

Apple is a registered trademark of Apple Computer Inc.

**RCA**  
 Only **\$359<sup>00</sup>** Modem built-in!  
**VP-3501 Videotex Data Terminal**  
 Turn your home TV into a time-sharing videotex display

**Commodore**  
**VIC 20 COMPUTER** w/RF Modulator  
**PRICED TOO LOW TO PRINT**

- VIC 1540 Disc Printer 459.95
- 16K Memory 99.95
- 8K Memory Expansion 53.95
- DATA Tape Recorder (f/Cass. Prog.) \$67.95
- Phone Modem (VIC) by Bizcom 129.95
- Modem by VIC 109.95
- Super Expander 57.95
- VIXEL I or VIXEL II 11.50
- VIC MON 52.00
- Programmers Aid 52.00
- Joystick for VIC 14.95
- Monitor Cable 12.95
- Snackman (cass.) 16.95
- Household Finance (cass.) 29.95
- Loan Analyzer (cass.) 17.95
- VT 106 A or VT 107 6 Pk. Rec. Prog 49.95

**QUANTUM DATA**

- 24K Memory 179.95
- Expansion Interface 64.50
- RS 232 Interface 47.95

**ATARI**  
 ATARI 800 w/16K . . . . . \$649<sup>00</sup>  
 ATARI 400 . . . . . \$329<sup>00</sup>  
 810 Disc Drive . . . . . \$459<sup>00</sup>  
 850 Interface . . . . . \$179<sup>00</sup>  
 410 Programmable Recorder \$79<sup>00</sup>  
 Axlon 32K Ram . . . . . \$129<sup>00</sup>  
**POPULAR ATARI GAMES IN STOCK!**

**Texas Instruments TI 99/4A COMPUTER**  
**FREE! RF Modulator (\$50 Value!)**  
 w/purchase of TI 99/4A

Only **\$299<sup>00</sup>**  
 2 FREE Offers from TI Up to \$140 savings!  
 Call or Write for Details!  
 Full line of hardware, software and accessories in stock!

**We carry the full line of TI and HP Programmable Calculators.**

**\* SHARP MINI COMPUTERS \***

- PC-1500 LCD POCKET COMPUTER  
 Extended BASIC system capable of 2 dimens. arrays. Full graphic commands.  
 Now Only \$214<sup>95</sup>
- CE-150 Color Graphics Printer with Cassette Interface  
 Now Only \$174<sup>95</sup>
- 4K and 8K Memory Expansion IN STOCK!

**hp HEWLETT PACKARD**  
**HP-87A**  
**Rapid Programming Power!**

Has 32K bytes of user memory, expandable to 544K. Versatile alphanumeric keyboard. High resolution CRT. Built-in HP-IB interface, printer and mass storage firmware. Built-in BASIC and operating system.  
**Call or Write for Low Price!**

32K, 64K and 128K Memory  
 Expansion Modules In Stock!

**Special! HP-83 (Ltd. Qty.) \$1295<sup>00</sup>**  
 HP-85A . . . . . Call or Write  
 HP-125 Reg. \$2750 Only \$1982<sup>00</sup>  
 HP 82091M 5 1/4" Disc Drive \$1695<sup>00</sup>  
 HP 82905 Serial Printer \$619<sup>00</sup>  
 HP 7470A New Plotter \$1269<sup>00</sup>

**PRINTERS**  
 \* \* \* EPSON \* \* \*  
 MX-80 III F/IT 80-136 Column Dot Matrix Tractor or Friction Feed, Bidirectional, 80 CPS, Graftrax Plus . . . . . 549.95  
 MX-100III F/IT 136-233 Column, Tractor or Friction Feed, Bidirectional, 80 CPS, Graftrax Plus . . . . . 719.95

**OKIDATA**  
**MICROLINE 82A** 120 CPS, Bidirectional, Parallel-Serial, 80/132 Columns, Friction & Pin Feed 449.95  
**MICROLINE 83A F/IT** 120 CPS, Bidirectional, 136 Columns, Serial/Parallel, Friction and Tractor 699.00  
**New! MICROLINE 84A F/IT** 200 CPS, Bidirectional, 136 Column, Parallel, Friction and Tractor 1149.00  
 Serial w/2K Buffer 1259.00  
**New! C.I.TOH 1550** 120 CPS, 136/232 Column, F/IT Graph Parallel . . . . . 769.00  
 Parallel and Serial . . . . . 809.00  
**C.I.TOH F-10** Daisy Wheel, Letter Quality Printer, 40 CPS, Parallel 1499.00  
 F-10 Serial 1549.00

**MONITORS**

- USI PI-2 12" High Resolution Green 159.00
- USI PI-3 12" High Resolution Amber 189.00
- SANYO 12" Green 219.95
- SANYO 13" Color 389.95
- AMDEK 13" Color 369.00
- AMDEK Color II RGB High Res 769.00
- AMDEK Color Interface Board (IRGB) 159.00
- NEC JB 12" Green 179.95
- NEC JC 12" Color 349.95
- BMC-1200 12" Green 149.00
- ELECTROHOME ECM-1302-1 13" RGB Monitor Lowers with NTSC Interface (Reg. 600.00) 420.00

**47st. Computer**  
 Computers and Business Equipment  
 A Division of 47st. Photo Inc.

**OPEN SUNDAY**

**800-221-7774**  
**800-221-5858**

67 West 47th Street, New York, N.Y. 10036  
 115 West 45th Street, New York, N.Y. 10036  
 MAIL ORDER ADDRESS: 36 E. 19th St, New York, N.Y. 10003

Items on sale for limited time only, and are subject to limited availability. Not responsible for typographical errors. This ad supersedes all other ads prior to Sept. 1982. Prices effective as of August 28, 1982, and are subject to change without notice. All orders subject to verification and acceptance. Minimum shipping and handling \$4.95



## Beer Run

Arthur Little  
Technical Editor

Beer Run—a game with a straightforward purpose. No longer shall I dwell in a maze of twisty tunnels, watch my cities get nuked, or send another Federation Starship into ignominious defeat. No indeed, because from now, I'm a Beer Runner with only one goal in mind: collecting lagers.

In the interest of accuracy (and decorum), I should point out that this Beer Run is of the nonalcoholic variety provided by the folks at Sirius Software. In fact, Beer Run is a high-speed, color-graphics game designed for the sober and studious Apple II user. Studious, anyway.

### Your Goals

According to the documentation, the object of the game is to catch the elusive Artesians as you move through the levels of the building. It goes on to say:

*Usually they (Artesians) will be on the platforms just above you. Ladders and elevators are used to climb upward through the Sirius Building. If you reach the roof,*

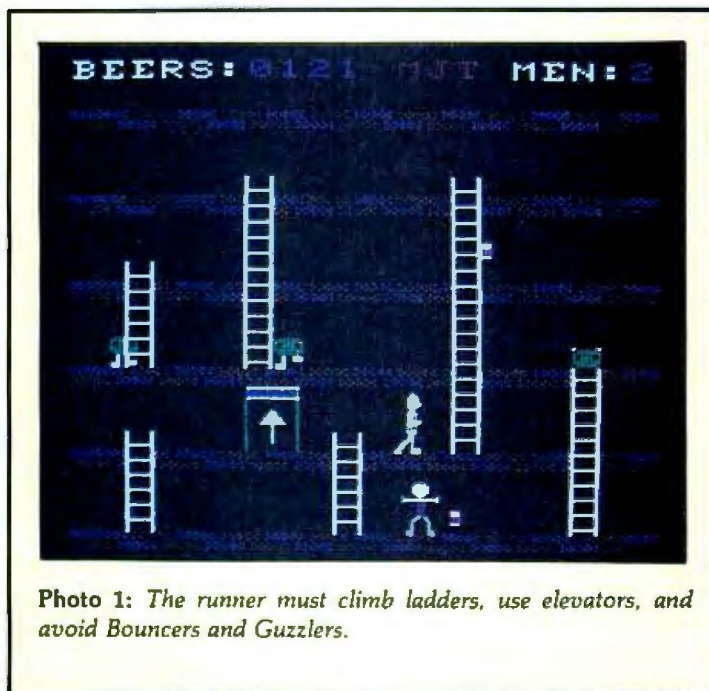

Photo 1: The runner must climb ladders, use elevators, and avoid Bouncers and Guzzlers.

*the Sirius blimp will transport you to the roof of the Olympia Brewery building next door.*

Basically, the idea is to climb to the top of the first building, cross over to the second building, and then descend. This is a cross-section, multi-level game that is faintly similar to the arcade game Donkey Kong or to the well-known Apple Panic (see Gregg Williams's "Apple Panic," March 1982 BYTE, page 68). It's also reminiscent of the children's board game Chutes and Ladders in that the runner

strives to go up and (too often) ends up back at the bottom.

You also want to increase your score, based on the total number of beers that you collect during your hunt. You collect beers in one of four ways:

1. The unseen Artesians will drop individual beers from above. If your runner's hand touches one as it falls, it's added to your cumulative score.
2. As you move up and down through the building, you may run across beer kegs. If you press the space bar as



## BYTE'S ARCADE

### At a Glance

**Name**

Beer Run

**Type**

Arcade-style game

**Manufacturer**

Sinus Software  
10364 Rockingham Dr  
Sacramento, CA 95827  
(916) 366-1195

**Price**

\$29.95

**Author**

Mark Turmeil

**Format**

5¼-inch floppy disk

**Language**

6502 assembly language

**Computer**

Apple II or II Plus with 48K bytes of memory and one disk drive  
(DOS 3.2 or 3.3)

**Documentation**

Two-page folder

**Audience**

Apple owners and game lovers

## TEST SCORING AND DAILY ATTENDANCE PROGRAMS

**P**ut low-cost and efficient testing and attendance software to work on your school's Apple II computer. With HEI's mark sense card reader, you can efficiently handle a variety of test scoring, progress monitoring and attendance recording needs.

The HEI reader accurately reads pen or pencil marks in a variety of colors. Cuts down on keyboard time, and improves the accuracy of your data. Best of all, it's ready-to-run with good educational software.

HEI offers a number of proven programs for use with the Model 121-4 card reader, each written and refined by professional educators, each provided with complete documentation. This software is menu-driven, and easy to use even for those with no previous computer experience.

HEI can supply everything from the Model 121-4 reader and software to a complete turn-key educational computer system. Call or write for literature and prices.

\*Apple is a registered trademark of Apple Computer, Inc.

# HEI inc.

Victoria, MN 55386 • 612-443-2500

- you pass the keg, its numeric value is added to your score.
3. Riding either up or down in an elevator gives you a minimum of 25 beers—and often more.
4. Finally, you get beers for successfully negotiating the interbuilding blimp ride.

### Play Commences

After booting the disk, the title pages come on screen and you are introduced to the two creatures you'll want to avoid during your search: the Guzzlers and the Bouncers. If your runner comes into contact with either, the runner plummets to his death—you are given three runners per game.

When the game begins, you see the first five levels or platforms. As you move up and down throughout the building, you will see a tier of five levels (e.g., Levels 6 to 10), each with a unique pattern of connecting ladders. (See photo 1 for a view of Levels 6 to 10.)

### The Controls

Your runner edges along the platforms and climbs the ladders. You control his movements using the keyboard

# CMC SuperSystems™

## SuperFive, SuperTen™ and now Super20™

CMC International introduced the first microcomputer offering the speed and capacity of Winchester hard disk technology in an affordable, attractive desktop unit. First was the SuperFive a 6.4 megabyte hard disk with a floppy drive for loading programs or for backing up data from the hard disk. Then came the SuperTen with a 12.8 megabyte hard disk, and an add-on hard disk subsystem, the Targa.

Now CMC has introduced the Incredible Super20, featuring 19 megabytes of hard disk storage in a 5¼" hard disk. It's offered at a list price of \$7695, the best price/performance ratio in the industry.

And now the SuperFive and SuperTen are even more affordable, with a suggested list price of only \$5995 for the SuperFive and \$6995 for the SuperTen. Microsoft Basic 80 is included.

CMC's SuperFive, SuperTen and Super20 support wide applications under their standard CP/M operating system with unexcelled system utilities.

There's a variety of compatible software including Basic compiler, Fortran, Cobol, Pascal and PL/1 80. Applications software, too, like dBasell, Accounting Plus, Wordstar and other Micropro products.

As an integrated system, CMC's SuperSystems provide both data processing and word processing capa-

bilities to meet the needs of a small business or a large corporation. Our systems are already part of Fortune 500 companies, and small businesses, too, speeding up information processing.

CMC's SuperSystems communicate with other systems, too, with optional software.

CMC didn't stop there.

First of all, we make it extremely reliable with extensive testing and by using the most reliable storage technology and components available.

Next, we offer it in different capacities, like 6.4, 12.8 and 19 megabytes, with a choice of 350 or 700 Kb floppy backup.

Then, we offer options including 220v, 50hz for international markets.

CMC then offers a module swap program in the unlikely event you'd ever need it to get back up and running — rapidly. And third party maintenance service nationwide, soon available in Canada.

Finally, CMC offers its SuperSystems with two RS232C ports, 64k RAM, two Z-80 processors operating at 4 MHz, a screen format of 25 lines x 80 characters, full ASCII keyboard and numeric keypad and cursor controls, graphics capability, reverse video, lower case descenders, and a battery-operated real time clock. Floppy disk versions also available.

Circle 87 on inquiry card.



# CMC INTERNATIONAL

A Division of Computer Marketing Corporation

11058 Main • Suite 220 • Bellevue, WA 98004 • Phone (206) 453-9777 • Telex: 152556 SEATAC

Call Toll-Free 1-800-426-2963

For information or to buy your SuperSystem, see your local CMC dealer today or contact:

Compu Data  
1 Bala Cynwyd Plaza  
Bala Cynwyd, PA 19004  
(215) 667-6843

Diversified Data  
8043 W. 82nd  
Indianapolis, IN 46278  
(317) 253-5878

Input SRL  
Chile 1830  
1227 Buenos Aires, Argentina  
Telex: 9191FINCO

Featherbed (Pty.) Ltd.  
415 Commissioner St.  
1st Floor  
Johannesburg, S.A.  
618-4728  
Telex: 80310 S A

Dialog Computer Treuhan  
Seeburgstrasse 18  
6002 Luzern  
Switzerland  
Telex: 72227 DCL

Software Control  
2101 N. Aurelius Rd  
Holt, MI 48842  
(517) 694-4142

"See us at Comdex Booth 4128"

# THE GREAT 1982 BREADLINE SPECIAL

Exec-Jr with 35 MBYTE Fixed Disk Subsystem and 192K RAM

A MULTI-USER BRIEFCASE SIZE  
COMPUTER SYSTEM WITH:  
4 - TERMINAL INTERFACES;  
4 - SERIAL PRINTER PORTS;  
1 - CENTRONICS PORT;  
DUAL 8" SLIMLINE  
DRIVES WITH 1.2  
MBYTES STORAGE;  
35 MBYTES HARD  
DISK STORAGE  
AND 1 NET-  
WORK PORT

**\$8495**

MPM II™  
INCLUDED.  
COMPACT SIZE  
5½" × 19" × 19";  
EACH FIXED  
DISK SUBSYSTEM  
IS HOUSED IN  
A SEPARATE  
EXEC-JR  
CASE.

Z80A  
4 MHZ  
PROCESSOR

IF YOU NEED  
MORE STORAGE  
THEN GET OUR  
70 MBYTE  
SUBSYSTEM  
SPECIAL  
for only  
**\$9980**



## The Breadline Special!

(OFFER BEGINS SEPTEMBER 1, 1982 AND ENDS OCTOBER 30, 1982)

*If you can buy this capability for less - then you probably in the business!*

CUSTOM COMPUTER SYSTEMS INC.  
AN INNOVATIVE LEADER IN PROCESSING SYSTEMS

Presented By



TERMINALS AND PRINTERS ARE NOT INCLUDED IN BREADLINE SPECIAL.  
PRICE AND AVAILABILITY SUBJECT TO CHANGE WITHOUT NOTICE.  
REPRESENTATIVE INQUIRIES WELCOME.  
MP/II IS A TRADEMARK OF DIGITAL RESEARCH, INC.

7250 COMMERCE CIRCLE EAST • FRIDLEY, MINNESOTA 55432 • PHONE (612) 574-9493

or game paddle. Using the keyboard, you press the left or right arrows to move left or right. To climb a ladder, you station the runner at the bottom and press the space bar. For a multilevel ladder, each time you press the space bar another level is scaled until the top is reached. Descending a ladder is trickier. The runner can go down only one level at a time, beginning at the top of each new ladder. Again, you must press the space bar. (That is, you must find a ladder that ends on the platform you are walking on.)

To move between tiers, your runner must ride an elevator, which will appear anywhere on the five platforms in view. Furthermore, it may be headed up or down. Because it is on the screen for short periods of time, it's often a good idea to get to the elevator as fast as possible. Once the runner disappears behind the elevator door, press the space bar and the ride will begin accompanied by appropriate sound effects.

The only other controls of note are the ESC key, which freezes all action until pressed again; CTRL-S, which toggles the sound on or off; and CTRL-R, which resets the game.

### Tactics, Strategy, and Stayin' Alive

Because the runner always begins a tier at the lowest row, one of the first things you'll notice is differences in the Bouncer's and Guzzlers' motions. The Bouncer can start at any of the four upper platforms; moving back and forth like a sentry, his speed ranges from very slow to very fast (depending on the level). The Guzzlers—and they are always in multiples—begin on the third and fourth levels above the runner and attempt to track and kill him. The Guzzlers' major weakness is that they usually change direction when they reach a wall, ladder, or platform. For example, they will descend only one ladder level at a time; therefore, the runner can move toward them with some confidence that they will move away. This pattern is more than compensated for by the fact that the longer the runner stays within a given five-level tier, the more Guzzlers will arrive!

In *pre-desperate* situations, I have been known to press the ESC key to get a more leisurely overview of the activities. It doesn't help much, but I still do it.

### Scoring Beers

The problem with trying for the individual beers falling down is that, for me, it's just not cost-effective. Stopping for the kegs also slows one down, but I do collect them in two circumstances: when the runner is very near the elevator and I'm feeling confident or if I'm trapped and facing certain doom anyway. For consistently high scores, look to the elevators and the blimp.

### Catching the Blimp

The documentation tells you to catch the blimp, but not how to do it. Here's the trick: the blimp moves across the screen from left to right, so position your runner on the left side of the roof. The blimp will be trailing a rope from its stern. Move your runner across the roof beneath the rope and wait for it to descend. Then press the space bar. Try to catch the rope on the first flyby for extra points.

### Conclusions

Beer Run is witty, well thought out, and well executed. The musical sound effects are coordinated to your on-screen fortunes and add a comic relief to the proceedings. However, I appreciated the inclusion of an audio off/on switch within the program.

I enjoy the increasing difficulties encountered (more Guzzlers, tougher layout) the further I progress, so the game remains a challenge.

Though I have yet to sight, much less catch, an Artesian, I'm not about to quit. Beer Run is a hearty brew of a game. I'm sure you'll be amused by its impertinence. ■

## NEW! M-68000 SINGLE BOARD COMPUTER

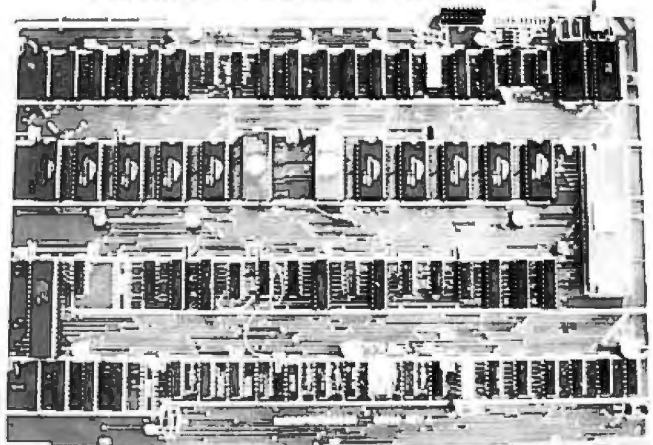

### FEATURES:

16 bit Motorola 68000 CPU operating @ 10MHz, 20K bytes of on board fast static RAM, 16K bytes of on board EPROM space, 7 levels of prioritized autovectorized interrupts, 2 memory expansion buses (up to 256K), 2 serial communication ports (RS-232C), 16-bit bidirectional parallel port, 6800 peripheral accommodation bus, 5x16-bit counter/ timers with vectored interrupts, on board real time clock, software compatible with Motorola MEX68KDM board.

### PRICE:

Bare board with documentation .....	\$99.95
MEX68KDM compatible monitor in 2764 EPROM's .....	\$120.00
M68000 CPU & memory map PROM .....	\$115.00
Shipping and handling .....	\$3.00
	(Domestic)
	(Foreign) .....
	\$15.00

( CALIFORNIA RESIDENTS ADD 6% TAX

**EMS** Educational  
Microcomputer  
Systems

P.O. BOX 16115 IRVINE, CA 92713-6115

(714) 553-0133

# BYTE'S Best Cellar List



## Ciarcia's Circuit Cellar, Volumes I, II, & III by Steve Ciarcia

Collections of Steve Ciarcia's perennially popular columns from BYTE Magazine, these three volumes are sure to please home computer users and electronics hobbyists. **Volume I** includes power conversions, programming EPROMs, remote terminal interfacing, touch-input video display, and more. **Volume II**, focusing on projects which interface the personal computer with the home, features useful applications such as a computer-controlled home security system, computerized appliances, input-output expansion for the TRS-80, and even a computer-controlled wood stove. **Volume III** offers low-cost construction projects such as an ultrasonic rangefinder, handheld remote computer control, two speech synthesizers, and a remote-control motorized platform, to name just a few.

## Build Your Own Z80 Computer

This complete guide to building a working computer offers engineers, students, and hobbyists an exciting alternative to buying a computer. With clear instructions, Steve Ciarcia fully explains how to build a basic single-board micro-computer based on the Zilog Z80 microprocessor. The finished product features a 1 K-byte operating system, serial and parallel ports, hexadecimal display, audio cassette mass storage, and easy expansion to include a video terminal.



Please send

- Ciarcia's Circuit Cellar, Vol. I \$8.00
- Ciarcia's Circuit Cellar, Vol. II \$12.95
- Ciarcia's Circuit Cellar, Vol. III \$12.95
- Build Your Own Z80 Computer \$15.95

Call Toll-Free 800/258-5420

Name _____			Check Enclosed _____
Address _____			Bill Visa/ MasterCard # _____
City _____	State _____	Zip _____	Expiration Date _____



70 Main Street Peterborough, N.H. 03458

Please add .75 per book to cover shipping cost.

B9

# Your TRS-80 video screen will come to life.

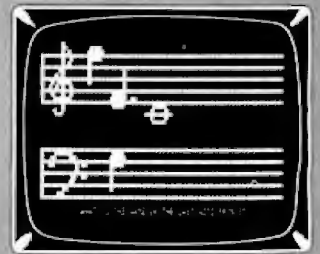
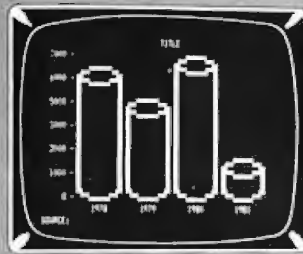
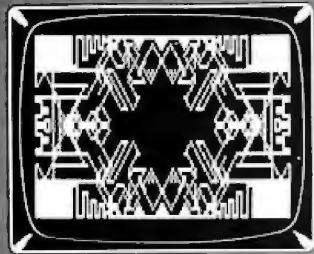

Bring your TRS-80 computer's video screen to life with the many striking graphics displays and functional programming techniques presented in this exciting and easy-to-follow new book!

Beginning with the basics, the authors introduce you to the tools of computer graphics, including the capabilities of the video screen, keyboard and character control, and graphics programming techniques such as concatenation, looping, and using subroutines and strings. The real fun begins as you learn how to create vivid displays ranging from business charts and mathematical function plots to dragons and lions, laser cannons, beautiful artistic designs, and a unique animated figure called Critter. Complete program listings and suggestions for modifications accompany each of the more than 100 graphic displays.

Besides providing guidance to those interested in specific applications, this book also serves the novice as an excellent introduction to programming in BASIC and machine language.

Written in a witty, readable style and complemented by over 100 detailed illustrations, *TRS-80 Graphics for the Model I and Model III* is both a thorough guide and an invaluable reference for anyone interested in the exciting field of computer graphics.

ISBN 0-07-033303-3

288 pages

Softcover

Illustrated

Price \$12.95

Prepayment is required.

Please add \$1.00 to cover shipping cost.

Order Toll-Free 800/258-5420

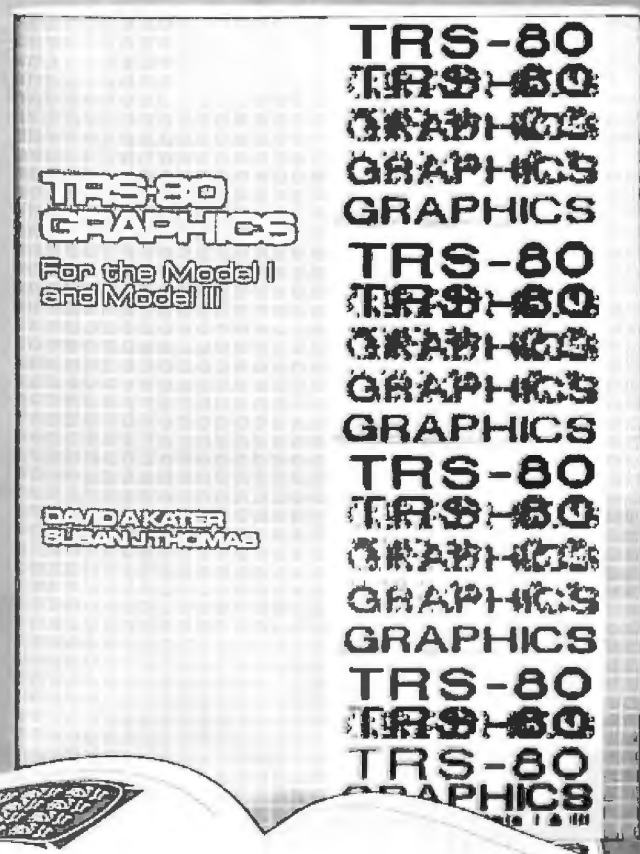

BYTE/McGraw-Hill 70 Main Street Peterborough, NH 03450

Circle 70 on inquiry card.



Modems	Manufacturer	Model #	Price
Novation	CAT		\$159.00
Novation	d-CAT		\$170.00
Novation	Auto-Cat		\$229.00
DC Hayes	Smart Modem		\$235.00
DC Hayes	Micro Modem II (Apple)		\$320.00
DC Hayes	Micro Modem 100		\$320.00
Lexicon	Lex-11		\$139.00
Livermore	LIV-Star 20M		\$149.00
Signalman	Mark I		\$89.00
UDS	UDS 103 LP (300 Bd)		\$185.00
UDS	UDS 202 LP (1200 Bd)		\$245.00
UDS	UDS 212 LP (1200 Bd)		\$455.00
UDS	UDS 212 ALP (1200 Bd)		\$650.00

Monitors	Manufacturer	Model #	Price
Amdtek	100/12" B&W		\$110.00
Amdtek	300G/Green		\$165.00
Amdtek	Color-1/13"		\$350.00
Sanyo	DMS109CX/9" Grn.		\$175.00
Sanyo	DM 5012/12" B&W		\$215.00
Sanyo	DM 5112ex/12" Grn.		\$225.00
Sanyo	DM C6013/13" Color		\$425.00
Zenith	ZVM-121/12" Grn.		\$115.00

Terminals	Manufacturer	Model #	Price
Ampex	Dialogue 80		\$780.00
Ampex	Dialogue 81		\$885.00
Televideo	TVI 910		\$625.00
Televideo	TVI 912C		\$725.00
Televideo	TVI 925		\$825.00
Televideo	TVI 950C		\$990.00

### SYSTEMS WITH SPICE from CALIFORNIA COMPUTER SYSTEMS

#### FOR APPLE II™ USERS

**Synchronous Serial Interface**  
Part Number 7712A ..... Price: \$149.00

**Programmable Timer**  
Part Number 7440A ..... Price: \$110.00

**Asynchronous Serial Interface**  
Part Number 7710A ..... Price: \$139.00

**Calendar/Clock Module**  
Part Number 7424 ..... Price: \$110.00

**3 1/2 Digit BCD A-to-D Converter**  
Part Number 7470A ..... Price: \$110.00

**12K ROM/PROM Module**  
Part Number 7114A ..... Price: \$105.00

**Parallel Interface**  
Part Number 7720A ..... Price: \$115.00

**Arithmetic Processor**  
Part Number 7811A ..... Price: \$349.00

**Centronics Printer Interface**  
Part Number 7728A ..... Price: \$105.00

#### FOR S-100 USERS

**32K Static RAM Board**  
Part Number 2032C ..... Price: \$475.00

**16K Static RAM Board**  
Part Number 2116C ..... Price: \$290.00

**64K Dynamic RAM Board**  
Part Number 2065C ..... Price: \$375.00

**Z80A CPU Board**  
Part Number 2810A ..... Price: \$295.00

**Floppy Disk Controller**  
Part Number 2422A ..... Price: \$365.00

CP/M™ Version 2.2 Free With Purchase

**S-100 Mainframe**  
Part Number 2200A ..... Price: \$475.00

**S-100 Motherboard**  
Part Number 2501A ..... Price: \$150.00

**4-Port Serial I/O Interface**  
Part Number 2710A ..... Price: \$295.00

**2-Serial, 2-Parallel I/O Board**  
Part Number 2719A ..... Price: \$325.00

**4-Port Parallel I/O Board**  
Part Number 2720A ..... Price: \$255.00

#### Connectors

	1-8	10-24	25 up
DB25P	\$2.00	\$1.90	\$1.75
DB25S	\$2.95	\$2.75	\$2.50
DB25C	\$0.95	\$0.85	\$0.75

### DISKETTES from ASAP

Verbatim 5 1/4" Diskettes		
Part #	Sector	Price
MD525-01	Soft	10/\$27.50
MD525-10	Hard 10	10/\$27.50
MD525-16	Hard 16	10/\$27.50

8" Diskettes		
Part #	Sector	Price
FD32-1000	Hard	10/\$35.00
FD34-1000	Soft	10/\$35.00

Memorex 5 1/4" Diskettes			
Part #	Side/Dens	Sector	Price
MEM 3481	1/Dbl	Soft	10/\$27.50
MEM 3483	1/Dbl	Hard 10	10/\$27.50
MEM 3485	1/Dbl	Hard 16	10/\$27.50

8" Diskettes			
Part #	Sector	Price	
MEM 3060	1/Sgl	Soft	10/\$35.00
MEM 3090	1/Dbl	Soft	10/\$45.00
MEM 3102	2/Dbl	Soft	10/\$55.00

Scotch 3M 5 1/4" Diskettes			
Part #	Side/Dens	Sector	Price
744-0	1/Sgl	Soft	10/\$33.00
744-10	1/Sgl	Hard 10	10/\$33.00
744-16	1/Sgl	Hard 16	10/\$33.00
745-0	2/Dbl	Soft	10/\$45.00
745-10	2/Dbl	Hard 10	10/\$45.00
745-16	2/Dbl	Hard 16	10/\$45.00

Maxell 5 1/4" Diskettes			
Part #	Side/Dens	Sector	Price
MD1	1/Sgl	Soft	10/\$32.00
MD2D	2/Dbl	Soft	10/\$44.00
MH1	1/Sgl	Hard 16	10/\$39.00
MH2D	2/Dbl	Hard 16	10/\$50.00

8" Diskettes			
Part #	Sector	Price	
FD1-128	1/Sgl	Soft	10/\$41.00
FH1-32	1/Sgl	Soft 32	10/\$41.00
FD2-X0	2/Dbl	Soft	10/\$50.00

### Elephant Memory Systems

Part #	Side/Dens	Sector	Price
EMS 1	1/Sgl	Soft	10/\$25.00
EMS 2	1/Dbl	Soft	10/\$27.50
EMS 3	1/Dbl	Hard 10	10/\$27.50
EMS 4	1/Dbl	Hard 16	10/\$27.50
EMS 5	2/Dbl	Soft	10/\$33.00
EMS 6	2/Dbl	Hard 10	10/\$33.00
EMS 7	2/Dbl	Hard 16	10/\$33.00

### SRW Media Storage Cases

Part #	Size	Price
SRW-5	5 1/4"	\$2.50 ea.
SRW-8	8"	\$3.25 ea.

ALL PRICES SUBJECT TO CHANGE WITHOUT NOTICE. CALL FOR BEST PRICE.

ASAP offers a 15-day buyer protection policy: full money-back guarantee if not totally satisfied

Ordering Information: name, address, phone; ship by: UPS or Mail. Shipping charge: add \$2.90 up to 1 lb (UPS blue), U.S. Mail add \$1.50 (U.S. only) (\$25.00 minimum order)

Terms: We accept cash, check, money orders, Visa and Master Charge (U.S. funds only). Tax: 6% Calif res., 6% L.A. County, COD's and terms available on approval (School PO's Accepted).

### ATARI® COMPUTER GAMES

#### ATARI® 800™

(16K) Personal Business Computer Features:

- Computer console
  - Atari® BK basic
  - 57 full stroke alpha-numeric keyboard with four function keys
  - Operator's manual
  - RF modulator
  - Power supply
  - also available 32K & 48K system
- Call for price

Software Description	Price
Atari®	
Basketball	\$ 27.00
Super Breakout	\$ 33.00
Chess	\$ 32.00
Video Easel	\$ 26.00
Star Raiders	\$ 37.00
Asteroids	\$ 32.00
Music Composer	\$ 44.00
Assembler/Editor	\$ 45.00
Teletink I	\$ 24.00
Space Invaders	\$ 33.00
Missile Command	\$ 33.00
Graph II	\$ 17.95
Mailing List	\$ 19.95
Touch Typing	\$ 19.95
Stock Charting	\$ 22.95
Stock Analysis	\$ 19.95
Bond Analysis	\$ 22.95
Word Processor	\$119.00
Personal Finance	\$ 64.95
Microsoft BASIC	\$ 75.00
Pac-Man	\$ 35.00
Centipede	\$ 35.00
Caverns of Mars	\$ 32.00

#### Atari® Optional Accessories

Model #	Description	Price
410	Program Recorder	\$ 80.00
810	Disk Drive System	\$470.00
822	40-Column Thermal Printer	\$299.00
825	80-Column Dot Matrix Printer	\$645.00
830	Acoustic Modem	\$159.00
850	Interface Module	\$175.00
CX30-04	Paddle Controls	\$ 17.95
CX40-04	Joysticks (pair)	\$ 17.95
A16KA	16K RAM Board	\$ 45.00

#### Components

4116's (200 nS)/5200-3	Price
Apple, TRS-80, Heath	
1-15	\$1.50 each
50-99	\$1.30 each
16-49	\$1.40 each
100 up	\$1.20 each

#### Printers

Manufacturer	Model #	Description	Price
Anadex	9501A		\$1,425.00
Citoh	8510AP	Prowriter (Parallel)	\$485.00
Citoh	8510ADC	Prowriter (Parallel & Serial)	\$665.00
Citoh	F1040PU	Printmaster (Parallel)	CALL
Citoh	F1040PU	Printmaster (Serial)	CALL
Citoh	1550	Prowriter II (Parallel)	\$740.00
Citoh	1550	Prowriter II (Parallel & Serial)	\$825.00
Diablo	630 RO		\$2,095.00
Epson	MX80 w/Graftrak Plus*		\$480.00
Epson	MX80FT w/Graftrak Plus*		\$575.00
Epson	MX100		\$725.00

#### \*Graftrak Plus Standard on all Models Printer Interfaces

Model #	Description	Price
AEI-1	Parallel Interfaces	\$40.00
SEI-1	Serial Interfaces for Epson	\$35.00
EPI-1	2K Serial Buffer for Epson	\$65.00
OKI-1	2K Serial Buffer for Okidata	\$109.00

#### Printer Cables

Model #	Description	Price
AEC-1	Parallel Cable to Apple	\$17.95
AEC-2	Parallel Cable to Atari®	\$19.95
RSC-1	RS232C Cable	\$19.95
RSC-2	Okidata/RS232C Cable	\$25.00
TRSE-1	Parallel Cable to TRS-80	\$18.95



1198 E. Willow St. Signal Hill, CA 90806 (800) 421-7701 • (213) 595-6431 • (714) 891-2663

ASAP COMPUTER PRODUCTS LTD. 116 Viceroy Road, D-12 Concord, Toronto, Ontario L4K1A9 Canada (416) 738-0500 (800) 268-1996



## Advanced Star Raider Tactics and Strategies

C. Donald Harris Jr.  
508 Misty Lane  
Friendswood, TX 77546

I assume that by now most people who own both an Atari 400 or 800 computer and the Star Raider game cartridge have either reached some level of proficiency or given up the challenge entirely and gone on to other interests. This article is directed toward those of you who have mastered the easier levels of the game, who thoroughly understand Atari's *Star Raider Users Manual*, and are ready to attempt more hazardous adventures.

From my viewpoint, the four levels of difficulty should be considered in two groups:

- The beginner group (Novice and Pilot levels) will be entirely satisfying for those of you who enjoy the game but wish to avoid addiction. At the beginner levels, your ship is small, almost indestructible, and will only be attacked from the front.
- The expert group (Warrior and Commander levels) requires considerably greater skills. Your ship is larger,



Photo 1: The view from the bridge of this "sit-in-'em" game of galactic strategy.

more vulnerable, and will be subjected to aft attacks or even simultaneous front and aft attacks.

I look at the Warrior level as basic training for the Commander level and suggest that your advanced training begin with that approach. Don't expect much in the way of rank at the Warrior level—the game-completion bonus is too low. A week or so of practice at the Warrior level will sharpen your skills considerably and, with the tips provided in this article, you should

be prepared for mastery of the Commander level.

### Overall Strategy

You should first reach a fair amount of proficiency at the Pilot level. For example, you should be able to fly "on instruments." Without stopping to think, you should know at once where *the Enemy*, the Zylon, is from the azimuth, elevation, and range instruments on the display and which way to move the joystick to maneuver your

# CALL "THE COMPUTER-LINE"™

When you call us, you talk to fully qualified computer specialists trained to answer all your questions pertaining to our line of microcomputers. We are renowned for our excellent after sales support and our promptness for delivery. Peace of mind and excellence in service is our pledge to all our customers.

## NEC PERSONAL COMPUTER

PC-8001A Keyboard and processor unit, including 32K Ram, 24KB N-Basic Rom, cassette tape recorder interface, parallel printer interface, display interface.  
\$749

PC-8012A Modular expansion unit, including I/O bus extension, diskette adaptor, 32KB Ram, real-time clock, 8 priority interrupt levels, 6 slots for additional boards.  
\$479

PC-8023A Dot matrix printer - 100 cps, bidirectional printing, proportional printer.  
\$499

PC-8031A Dual diskette unit, including two 163K byte diskette drives, interface cable, enclosure and operating system.  
\$749

We carry the entire line of NEC/BPI software for the personal computer. Please call or write for information.

## CALL FOR PRICES ON

- APPLE II
- FRANKLIN ACE
- BASIS 108
- RANA DRIVES
- TANDON DRIVES
- HARD DISK SYSTEMS

## COMPUTE-R-CADE™

WE CARRY THE  
REVOLUTIONARY GAME  
ARCADE BOOTH FOR ATARI  
AND APPLE COMPUTERS!  
CALL FOR INFORMATION AND  
PRICING

## MICROCOMPUTER BUSINESS INDUSTRIES

Appletime™ Clock Card	\$ 89
VIP™ Card. (The Ultimate graphics interface + cable)	\$99
All other VIP™ Cards	\$CALL

(See advertisement this Byte)

## CALIFORNIA COMPUTER SYSTEMS

7710 Async. Serial Int.	\$135
7490 GPIB (IEEE-488) Int.	\$239
7470 Ana. to Dig. Converter	\$ 99
7711 Async. Serial (Term)	\$135
7712 Sync. Serial Int.	\$149
7721 Apple Parallel Int.	\$109
Calendar/Clock Module	\$ 99
Programable Timer	\$ 99

## MOUNTAIN HARDWARE

CPS Multi-Function Card	\$169
The Clock	\$229
Supertalker	\$159
Music System	\$319
Expansion Chassis	\$599
Romwriter	\$139
Ram Plus (32K Board)	\$149

## PRINTERS

NEC Spinwriter 7710/7730	\$2339
8023A	\$ 489

EPSON (Grafix Plus)	
MX-80	\$ 429
MX-80FT	\$ 529
MX-100	\$ 699

All Epson and NEC dot matrix printer prices quoted are for immediate delivery inclusive of shipping, insurance and handling charges.



## INTEGRAL DATA SYSTEMS

PRISM 132 Color printer with all options

- 200 cps Sprint Mode
- 4-color printing
- Friction/Tractor feed \$1595

## C-ITOH

### F10 Word Quality Printer

- 40 CPS Printing

- Letter quality excellence

Now Only \$1395

Prowriter 120cps \$489.00

## BUSINESS SOFTWARE

### VISICORP, INC.

Desktop Plan III	\$229
Desktop Plan II	\$189
Visifiles	\$189
Visiplot	\$159
Visitrend/Visiplot	\$229
Visidex	\$189
Visiterm	\$ 79
Visicalc 3-3	\$189
Visipak	\$539

### STONEWARE

DB Master	\$169
DB Utility Pack	\$ 69

### MICRO PRO

Apple CP/M	
Word Star	\$219
Super Sort	\$119
Mail Merger	\$ 79
Data Star	\$179
Spell Star	\$119
Calc Star	\$119

## APPLE WORD PROCESSING *On line's Sensational*

Screenwriter II	\$89
-----------------	------

Call For Continental, Dakin 5, Broderbund, Automated Simulations, Avant-Garde, Edu-Ware, Denver, Howard, Sirius, Sensible, Synergistic Software, Etc

## COMPARE!

DRIVES FOR  
APPLE

WITH  
CONTROLLER  
\$429

ADD-ON \$359

Hard Disks + 8" Disks for Apple, TRS-80 \$CALL  
Apple Computer Products \$CALL



PRODUCTS • PLEASE CALL  
OR WRITE FOR CATALOG.

## MODEMS

Hayes Micromodem II	\$289
Hayes Smartmodem	\$229
Hayes Chronograph	\$199
Novation Cat	\$145
Novation D-Cat Modem	\$165
Novation Apple Cat II	\$339
Novation Auto Cat	\$209

## DISKETTES (Boxes of 10)

Verbatim Datalife	\$ 24-95
Verbatim 8"	
Double-Side/DD	\$ 39-95

## RAM CARDS

Davong 16K Card	\$ 89
Microsoft 16K Card	\$129

## T and G PRODUCTS

Game paddles	\$ 29
Joy Stick	\$ 44
Selecta-port Expander	\$ 49

CERMETEK	\$CALL
1200 baud modem	

## MONITORS

Zenith ZVM-121 Phosphor	
15 MHZ	\$119
NEC 1201 Phosphor	
20 MHZ	\$179
NEC 0112 Composite	
Color	\$335
NEC 2112 RGB Color	\$899
Amdek 300 Phosphor	\$185
Amdek Composite Color	\$355
Amdek IBM Compatible	
Color	\$749

## 80 COLUMN CARDS

FOR APPLE	
Wesper 80 Card	\$259
Vision 80 Card (Vista)	\$289
Videx 80 Card	\$259

## MISCELLANEOUS

APPLE PRODUCTS	
Enhancer II	\$ 119
Dana Apple Fan	\$ 39
Sup R Mod	\$27-95

IN COLORADO (303) 279-2727

# CALL "THE COMPUTER-LINE"™

## 1-(800)-525-7877

COMPUTERWORLD INTERNATIONAL, INC.

SUITE 133, P.O. BOX 81, WHEAT RIDGE, COLORADO, U.S.A. 80034-0081

TERMS: RETAIL/MAIL ORDER: ADD 1% SHIPPING (MINIMUM \$2.50) - UPS GROUND.

WE HONOR ALL MANUFACTURERS WARRANTIES AND EXCHANGE FAULTY GOODS IMMEDIATELY.  
SPECIALISTS IN APO AND INTERNATIONAL DELIVERIES.



RETAIL: 1019 8TH STREET  
GOLDEN, CO 80401

# COMPUTER GRAPHICS

Here's the way to keep up with the *latest applications* in this dynamic field.

Subscribe to Computer Graphics World. It's the world's only monthly magazine that deals exclusively with computer graphics *applications* across a broad spectrum of interests.

Applications are explored from the user's perspective. Areas covered include CAD/CAM, exploration, cartography, engineering, education, business systems, transportation, medicine, architecture, art, energy, training, communications, marketing, printing, video, microprocessors, data analysis, management, construction, etc.

You'll also get the latest news on hardware and software developments, meetings and conferences, personnel changes.

Subscribe today. Use the postage paid postcard below. Or call (800) 331-5959 in the continental U.S.A. (In Oklahoma please call (918) 835-3161) and you'll have all the latest ideas in hand!" Computer Graphics World, P.O. Box 122, Tulsa, Oklahoma 74101.

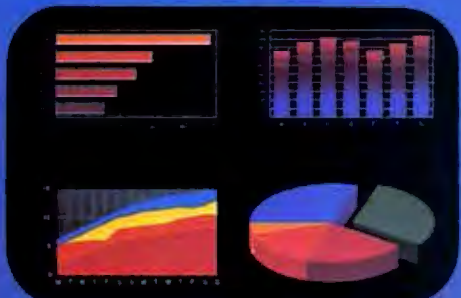
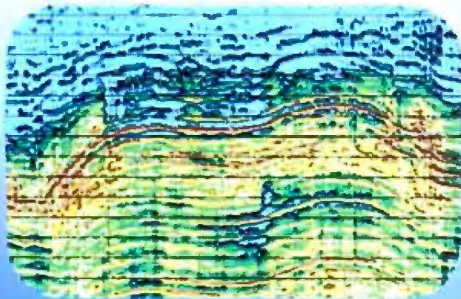

Please send me Computer Graphics World for one year (12 issues)  
Rates: \$30 U.S.; \$35 Canada & Mexico; \$40 Foreign; \$75 Foreign Airmail

Check Enclosed  Bill Me  Visa  MC Acct. No. \_\_\_\_\_

Cardholder's Signature \_\_\_\_\_ Expiration Date \_\_\_\_\_

Print Name \_\_\_\_\_ Title \_\_\_\_\_

Company \_\_\_\_\_

Street Address \_\_\_\_\_  Home  Business

City \_\_\_\_\_ State \_\_\_\_\_ Zip \_\_\_\_\_

- Please Circle One Number
- |  |   |  |
|--|---|--|
| 10 Manufacturer of Computer or DP Hardware Peripherals | 40 Public Utility Communications Systems-Transportation | 75 Business Service (except DP)                    |
| 20 Manufacturer (other)                                | 50 Wholesale Retail Trade                               | 80 Education Medicine Law                          |
| 30 DP Service  | 60 Finance/Insurance/Real Estate                        | 85 Government-Federal/State Local                  |
| Bureau Software  | 70 Mining/Construction/Petroleum Refining               | 90 Printing/Publishing/Other Communication Service |
| Planning/Consulting                                    |   | 95 Other: _____                                    |

Computer Graphics  
World

L006

PennWell  
PUBLISHED MONTHLY

# COMPUTER GRAPHICS WORLD

The most complete picture of the computer graphics industry today . . . and tomorrow.

Computer Graphics World will help you stay current with all of the innovations, changes and trends in the industry. Also it will help you understand where and how the new technologies apply.

**In-depth information.** You'll read features that explore computer graphics applications from the user's perspective in almost every industry and profession. Technological surveys give you a practical look at the hardware and software.

**Up-to-date news.** You'll get the latest news on industry developments . . . trade shows, conferences, meetings

and other special events . . . personnel changes and promotions.

**Insight.** You'll get the ideas and views you need to understand the rapidly changing industry. Leading authorities discuss their roles and particular interests. Reviews of new books give you a look at the ideas behind the developments. Letters to the editor present the opinions of the computer graphics community.

Subscribe today. Use the postage-paid postcard below. Or call (800) 331-5959.

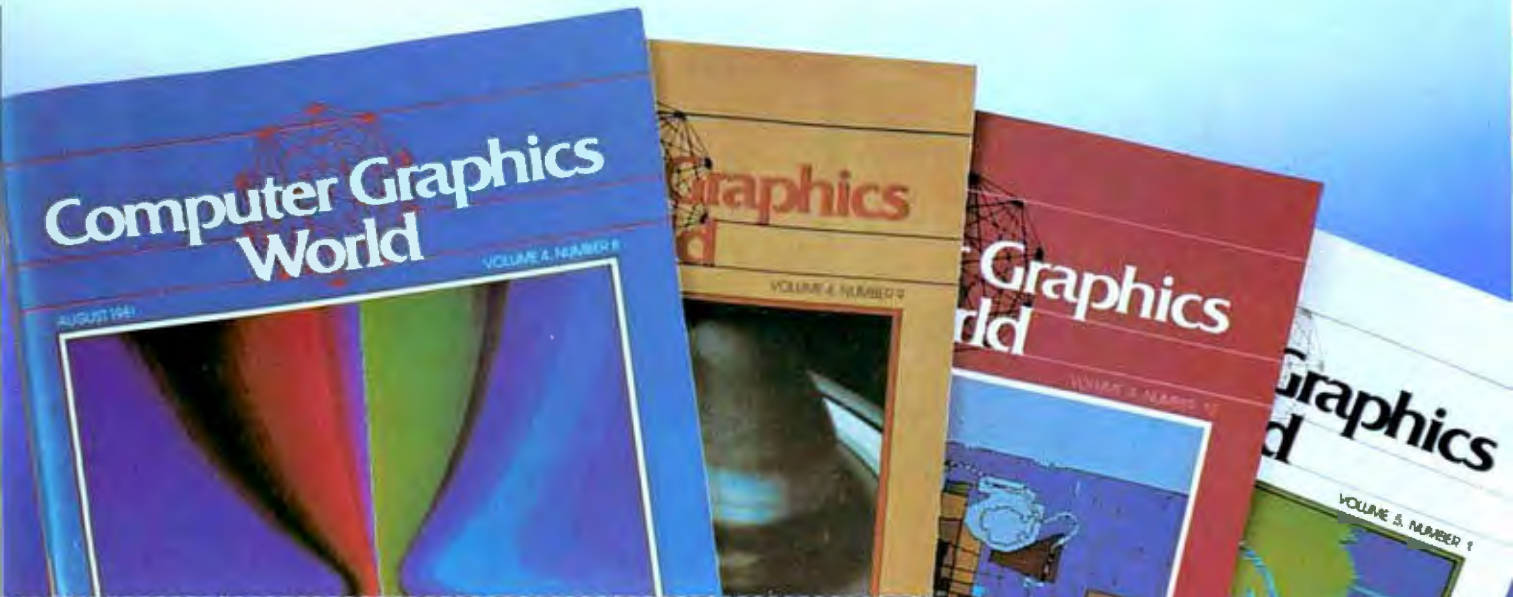

NO POSTAGE  
NECESSARY  
IF MAILED  
IN THE  
UNITED STATES

BUSINESS REPLY CARD

FIRST CLASS PERMIT NO 3 TULSA, OK 74101

POSTAGE PAID BY ADDRESSEE

**Computer Graphics World  
Publishing Company, Inc.,**  
P.O. Box 122,  
Tulsa, OK 74101



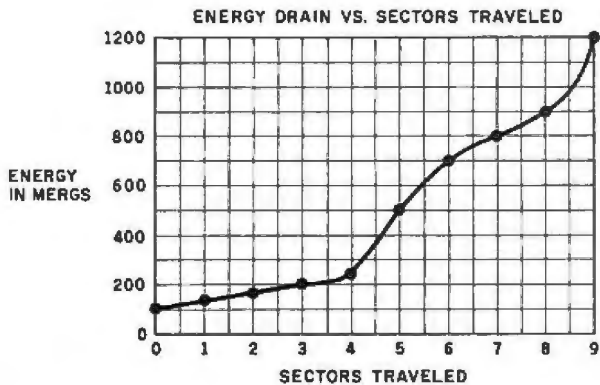

**Figure 1:** Energy drain for hyperwarp engine use. The drastic increase in energy use over distances greater than four sectors emphasizes the need to plan movement within the galaxy so that only short jumps are required.

craft. You should also know how to conserve energy during hyperwarp and when using the twin ion engines.

To properly prepare to wipe out your enemy, your battle plan should be designed around three priorities: survival, defense of starbases, and energy conservation. The main objective of course is survival (no easy task at the Commander level).

To begin the attack, switch to the Galactic Chart and press "P" (the Pause command). Now, it's study time: note the locations of your starbases in relation to the enemy's ships. This should help you plan your hyperwarp jumps from sector to sector more efficiently. The early-game strategy for defending starbases will include determining the starbase under attack and eliminating the fastest-moving enemy squadrons first. (Never go after a four-ship enemy squadron first, because you will find a starbase surrounded before you know it.)

You won't be able to figure out which starbase is first on the Zylons' hit list right away. It may take 150 to 200 centons (time units) of tracking enemy squadron movements to decide. In this interval, you should have blitzed your second or third two-ship squadron. Pick a nearby two- or three-ship fleet (they are faster!) and attack it. A caution: don't stray too far from the galactic center until you're certain which starbase to defend. You don't want to waste energy crossing the entire galaxy to begin your starbase defense. Don't forget about passing centons. Check the galactic chart during lulls in the fighting and note enemy-squadron movement. Don't forget to make your hyperwarps short jumps to save energy. Figure 1 shows the energy units used compared to hyperwarp distances out to nine sectors. Notice the large

energy increase for five sectors or more, and again over eight sectors. Once you've identified the starbase under attack, mop up the sector you are in, if you feel there is time, and move to defend your starbase.

As your attack continues, you should stay near the starbase under attack and let the Zylons come to you; but watch the tricky Devils—when you least suspect it they will switch starbases and begin moving to a new target. Continue to wipe out the two- and three-ship fleets first. Once you've done that, the pressure is off your starbases. Now that I've laid out the overall strategy, let's proceed with the fun part: wiping out the evil vermin.

### Behind Enemy Lines

While in an enemy sector and attempting to destroy Zylons, your objectives are survival and energy conservation. The main energy drains inside the sector result

*Text continued on page 392*

## PUT YOUR COMPUTER IN CONTROL WITH THE RX-10



The RX-10 is THE missing link between any computer system and the AC power lines to provide automated remote control of anything electrical in or around your home or office utilizing remote switches such as the BSR-X10® and LEVITON modules.

*The future is now; there has never been a better time to put your computer in complete control.*

#### Features and Applications:

- ✓ Utilizes advanced CMOS-LSI technology
- ✓ Direct line interface: complete 256 channel control
- ✓ Easy to program and use, cost effective and compact
- ✓ Extensive documentation & program examples included
- ✓ Reduction of excessive electrical bills
- ✓ Automation of security and lighting systems

BSR System X-10 is a trademark of BSR, Ltd.  
LEVITON is a trademark of Leviton Mfg. Co., Inc

**Contact us for more information and order forms.  
Dealer inquiries invited.**

Available From:  
**ENVIRONMENTAL CONTROL SYSTEMS**  
9319 Willowview Lane • Houston, Texas 77060 • (713) 464-1717

**Videosyncrasies**

Anyone who has not been a Star Raider might not understand the fascination that envelops one when playing the game—the many hours that go into learning how to swerve away from incoming photon torpedoes, the frustration of losing control of the ship while in hyperspace and then emerging in some empty nether region of the galaxy while the dastardly Zylons surround and destroy your last starbase. Atari's Star Raider is the first, and so far the best, of a genre that I call "sit-in-'em" games.

Let me explain that, as a Star Raider, you are actually sitting in your ship, seeing stars, Zylons, starbases, and the rest of a vast galaxy whiz by as if you were looking out a window. Don't confuse Star Raider with the more common "map" games like Space Invaders or Pac-Man, where you look down at a map of yourself and your opponents. In Star Raider, you are pilot of a one-man ship with all the expected properties of a military vessel capable of roving the galaxy: it has weapons, defenses, and communications equipment; it

has inertia; it can be damaged and, when it is, you are in trouble.

Although map games have their place (as evidenced by the continuing popularity of chess), this is the type of game that best employs the power of the computer, because it uses the computer to give you capabilities that would otherwise be impossible. It puts you somewhere you could not normally go. I must admit that "sit-in-'em" games are now the only type I will stoop to conquer. My jaded imagination can no longer be excited by watching my "blip" shoot at the computer's "blip" on a screen—too impersonal.

Star Raider is probably the single greatest contributor to the sales of Atari's 400 and 800 series computers. People seem to buy the computer just to get the game, and then they find out that it can be useful in other ways too (but Star Raider still gets top priority). If you're thinking about writing a game for personal computers, Star Raider is the one to beat.

Here's a collection of notes and observations I have

Text box continued on page 388

# Apple users. THE SOURCE<sup>SM</sup> and TRANSEND<sup>SM</sup>. Together for the first time for only \$89.

Buy our \$89 Transend state-of-the-art data communications software and membership in THE SOURCE, AMERICA'S INFORMATION UTILITY<sup>SM</sup>, is included. This combination allows you to easily access one of the world's largest information services for up-to-the-minute news and sports, stock prices, travel services and much more.

An optional 260-page Source User's Manual is available for \$19.95. Your dealer has complete details. Call 800-227-2400, ext. 912 (in Calif. 800-772-2666, ext. 912) for the name of your local Transend dealer. Offer expires Oct. 1, 1982.



Apple is a trademark of Apple Computer Inc. THE SOURCE and AMERICA'S INFORMATION UTILITY are service marks of Source Telecomputing Corp., a subsidiary of The Reader's Digest Association Inc.

## The Transformation People.



SSM Microcomputer Products Inc.  
2190 Paragon Drive, San Jose, CA 95131

# A Computer That Writes Programs For You.

## What will they think of next . . . ?

Technical Review  
by Wayne Hepburn

**QUIKPRO + PLUS** is a new breakthrough in software for microcomputers from ICR-FutureSoft.

Until now, whenever you wanted a new separate program in BASIC (Microsoft Basic/MBasic/Basic 80/Oasis Basic), you had to spend a lot of dollars for it, or a lot of hours creating it (if you have the know-how). That's all in the past now.

Anybody who can turn on a computer can write a program, quickly, with this new **Quikpro + Plus** software which generates programs for you. **Quikpro + Plus** is the invention of Joseph Tamargo of Florida. His brilliant approach to program writing allows you to tap the real power and speed of your microcomputer, and it is about time this happened.

I interviewed him to find out more about **Quikpro + Plus** and pass this valuable information to you. He told me "The best part of this software is that it gives you a separate custom program every time you use it. The resulting program is produced, error-free, in BASIC (Microsoft Basic/MBasic/Basic 80/Oasis Basic, as appropriate to your system) for you by **Quikpro + Plus**. What's more, you can list your new program, look at it, see what makes it tick, and modify it as you wish."

You can also, customize, enhance, alter, and even copy the programs you create with **Quikpro + Plus**. This is because programs created by **Quikpro + Plus** are structured, easy to follow, and include many REMARKS statements right in the program listing. I don't know of any other software with the flexibility and ease of use I found in **Quikpro + Plus**.

### HUNDREDS OF APPLICATIONS...

For Education, Business, Hobby, Home, Science, Personal, etc. a partial list includes programs like these: Financial Forecasting, Expense Planning, Data Access and Retrieval, Modeling, Record Keeping of all kinds, Statistical Data Banks, and much, much more. **Quikpro + Plus** cuts the time it takes to generate a new custom program down to a few minutes. That's true. I saw a

letter from a user who created a separate program in Basic within fifteen minutes after reading the clear, simple, complete Documentation & Operating Manual for **Quikpro + Plus**. The software will generate File Handling and Data Entry Programs in a file format, drawn right on the screen by user. Programs created by **Quikpro + Plus** produce standard ASCII Data Files allowing data to be easily accessed by other programs, other micro's, and even main frames.

### HOW IT WORKS...

The operation of **Quikpro + Plus** is simple and easy. On your screen you answer questions which appear in plain English. The answers generate error-free Filing & Data Entry Programs for you...instantly. This completely eliminates the tedious and time consuming development you normally go through to write a program. Since the instructions are right on the screen you don't need any programming skills to operate **Quikpro + Plus**. Quickly, you get a fully independent new program ready to run on your system. After you create the new program you can remove **Quikpro + Plus** and stick it on the shelf until the next time you create a custom program.

### PRINTS REPORTS & MANUALS...

There is a full report printing capability put into your new separate program by **Quikpro + Plus**. You can even print out in formats different from the File Format you used without altering the Record Data. Or you can selectively print portions of Files or selected fields from selected Records. Just about anything you want can be reported out from the Data Base associated with the new custom program you wrote.

### PERFORMS CALCULATIONS...

You can perform all manner of computations among various fields in each record. You can selectively calculate and print resulting data only, or Data Base and results, or alter Records by calculation results, and so forth. The possibilities seem unlimited. And keep in mind that the power and features I am talking about end up in the separate new custom program **Quikpro + Plus** writes for you.

This software is ready to ship immediately

and you can start writing programs the day you get in. In fact, ICR-FutureSoft guarantees your satisfaction or you can return it for a full refund in ten days after delivery. How's that for confidence? Mr. Tamargo said "There isn't any risk to us...our product works like it's supposed to work and users are very well satisfied. We are glad to guarantee satisfaction."

You get **Quikpro + Plus** by mail or phone directly from ICR-FutureSoft. Just write them, or call their Toll-Free phones and specify your model and version requirements from the list that follows:

**For CP/M with Microsoft Basic** \$259  
(same as MBASIC/Basic 80)

APPLE • INTERTEC • NORTH STAR • OSBORNE • XEROX 820 • HEATH • ZENITH • CROMEMCO • ALTOS • RADIO SHACK TRS80 • or any system reading CP/M 8" Single or Double Density.

**For MS/DOS Operating System** \$259  
IBM/PC • WANG

**For TRS/DOS Operating System**  
Radio Shack TRS80 Mod I, III \$149  
Radio Shack TRS80 Mod II, 16 \$189

**For ATARI Microsoft Basic** \$189

**For OASIS Operating System** \$349

ALTOS • COMPUCORP • CROMEMCO • DELTA PROD • DIGITAL GROUP • DIGITAL MICROSYSTEMS • DYNABYTE • GODBOUT • IBC INDEX • INTERSYSTEMS • NORTH STAR • ONYX • SD SYSTEMS • TRS80 II • VECTOR GRAPHIC • VORIMEX

Send check or money order (Florida residents and 5% tax) to ICR-FutureSoft, Box 1446 G, Orange Park, FL 32073 or if you have Visa or Mastercard, Call Free 24 hours daily, seven days a week...

**1-800-824-7888** ask for Operator #843  
California 1-800-852-7777 Operator #843  
Hawaii/Alaska 1-800-824-7919 Op #843

Operators cannot give technical help, accept orders only. Technical support call 1-904-269-1918.

Software Dealers can handle this software. Contact ICR-FutureSoft Customer Service at 1-904-269-1918 or write.

# NEVADA FORTRAN

**\$199.95**  
DISKETTE AND MANUAL

Just a beautiful compiler that's a pleasure to use! Perfect for Teaching Fortran. Perfect for Learning Fortran. Perfect for Scientists and Engineers. Advanced features include IF.. THEN.. ELSE.. constructs, COPY statement, a very nice TRACE style debugging, and 150 verbal error messages. What's more, you can Intermix in-line Fortran and Assembly Language statements for those special Micro needs! Get yours, today!

# NEVADA PILOT

**\$149.95**  
DISKETTE AND MANUAL

Why has Nevada PILOT become so popular? It's definitely easier to learn than Basic. The documentation (148 pages) by Professor Starkweather is exceptional! And, it meets all the PILOT—73 standards with many new features.

You can quickly write user-interactive programs much easier than with Basic. Order yours now! Diskette and manual comes with 10 FREE programs.

# NEVADA COBOL

**\$199.95**  
DISKETTE AND MANUAL

Nevada COBOL is based upon the ANSI—74 standards with many advanced features. It's field-proven with thousands of users world-wide in Business, Government and Education. The excellent documentation (153 pages) is used as a classroom text at a number of colleges.

Because of Nevada COBOL's superior design, it requires about half the memory of competitive COBOL compilers. This major advantage is just one reason many business programmers are switching to Nevada COBOL.

And, lots of students are using Nevada COBOL because it's the affordable, easy to use COBOL! Order yours now!

Also available: COBOL Application Packages Book 1 ..\$24.95  
Nevada SORT ...\$119.95 Nevada EDIT ...\$119.95

All our software requires the CP/M operating system, 32K RAM, one disk drive, CRT or video display and keyboard. Available on 8" standard single density or 5 1/4" diskettes for Apple II, Osborne I, North Star, Micropolis Mod II, Superbrain, TRS—80, IBM—PC and many other microcomputers. Dealer, Distributor, O.E.M Inquires invited.



**ELLIS COMPUTING**

600 41st Avenue,  
San Francisco, CA 94121

COD's WELCOME



**(415) 751-1522**

Trademarks: CP/M, Digital Research, TRS—80 Tandy Corp., Apple II, Apple Computer Inc., Osborne I, Osborne Computer Corp. IBM, International Business Machines. ©1982 Ellis Computing

## BYTE'S ARCADE

Text box continued:

made after, literally, several hundred hours of playing the game. These tricks and considerations, as well as those Mr. Harris mentions, are the ones that I now employ whenever I play Star Raider. If you are a beginner to the game, perhaps you might want to consider waiting to read this—a large part of the enjoyment of the game is learning how to win.

### Understanding the Zylons

- Never lose sight of the fact that the name of the game for the Zylons is destruction of your starbases. To do this, they surround a starbase, cut off its supplies, and kill it, then build two ships out of the wreckage.
- Once a starbase is surrounded, you have only a certain amount of time to save it.

### Planning

- Remember that while you are docked at a starbase, you can view the galactic chart and set up for your next hyperspace jump. That way, when "transfer complete" appears on your screen, you can immediately enter F (Forward view) and then H (hyperspace). Not only does this save time, but you get to watch the repair ship flash by (and probably scare the dickens out of its crew).
- Zylon task forces vary in size, but the smallest ones always move toward starbases the fastest; wipe them out first.
- Zylons jump into hyperspace on time units ending with .00 and .50, so check the time when you're planning your next hyperjump—if the clock is between .40 and .49 or between .90 and .99, it's worth your while to wait and watch time—they will very likely move out from under you if you don't.
- As long as your subspace radio is working, you will get a message whenever a starbase is surrounded. Early in the game, when there are a lot of fast Zylon squadrons around, it's best to go to the starbase's aid immediately.
- If you know you can't save a surrounded starbase, admit defeat and go in and blow it up yourself as soon as you can (see the next section on how to hyperwarp directly to starbases). You'll be penalized, but not as much as if the Zylons had done it; and this way, they don't get to use the wreckage to build more ships.

### Saving Energy

- If you want to, you can turn off shields, etc., to save energy during hyperwarps.
- You can usually hyperwarp directly to a starbase by centering the indicator on the attack-computer display as you enter the starbase's sector. This lets you "coast" right up to the base.

Text box continued on page 390



# IBM PC

## 192K RS232 SERIAL

# \$499

### ...what's the catch?

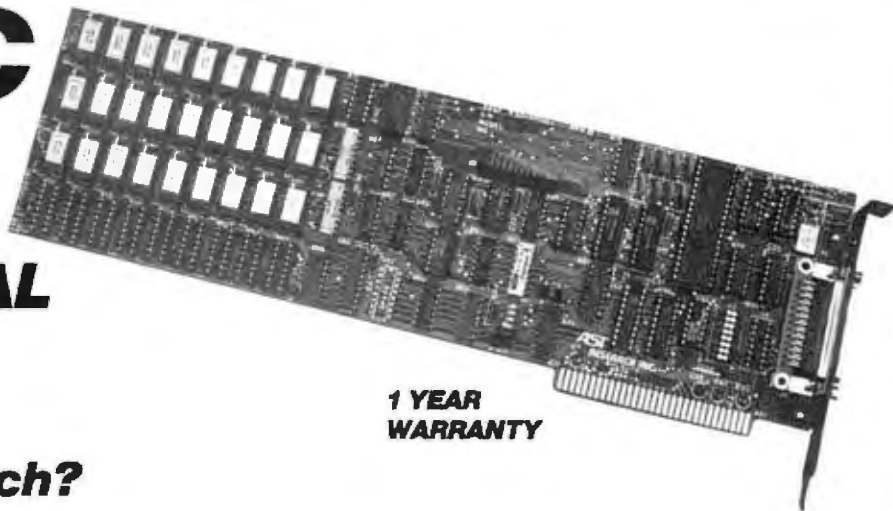

**1 YEAR  
WARRANTY**

Take a good look. This is the face of things to come. On one board in one slot, you get 192k of additional memory and a serial printer port. If you look close you will see the board has room to expand to 256k. You can even add a parallel port on the same board. And if that is not enough, by the time you read this we will have added another useful option — a real time clock.

#### IBM DIDN'T MAKE IT SIMPLE

Well that's good, because simple usually means limitations, and so far we have not found a lot of limitations. It is hard to pick IBM cards when you have only five slots. Now lets see. If you want graphics and color you buy one board. And if you want a printer port you buy another. Or you buy a monitor adapter and you get a printer port on the same board. When you want to add serial communication it's another board. Add some memory at 64k per board. Wait a minute. That's two plus one, plus one, plus one more, minus one if you don't want graphics — HELP!! Your PC is now a mass of boards and you still want to do more. Not only that, but you now have spent so much money on boards you may have to compromise somewhere else in your system.

#### A QUICK SURVEY

We decided the answer was a board that could do several jobs and use a single slot. First we called IBM to find out what kinds of boards and accessories are sold in what percentages. Wrong question. You would have thought we had asked what was on the missing 18 minutes of the Watergate tapes, because that's what we got — a long silent pause. The official answer was "that information is not available to non-IBM people." So we started calling dealers and asking them. Turns out that about 85% of the systems they sell have the monitor board with the printer port. The next most popular item is the asynchronous serial board, and then memory. Almost all of the salesmen we talked to tried to tell us we didn't want IBM 64k memory boards, and they would be happy to sell any num-

ber of aftermarket boards for prices ranging from \$795 to \$1195. A.C. Nielsen would be proud.

#### HOW IT'S DONE

Land. Printed circuit area is called land. If you have enough land, and you are real clever in how you use it, you can "grow" everything you want on one board. In this case we have enough land to do all the popular things. First 192k. This combined with the 64k in the PC gives you 256k. Just the right number. Count 'em. Nine per row of 64k bit chips so you get parity checking. Our board comes standard with an RS232-C serial port. All of the good things like solder masking, silk screening of parts locations, and of course gold plated connectors are standard. Each board is tested and burned in.

For an additional \$50 you can get a parallel printer port. On the little land we have left we are adding a real time clock which you can have for \$50. You can put in your own row of chips to increase the memory to 256k, but we won't warranty your row of chips. For \$100 we will add them to the board, test, burn in, and warranty them.

#### AN OFFER YOU SHOULDN'T REFUSE

One of the best things you can use the PC for is a spreadsheet program like Visicalc. That's how we figured out exactly how much this board cost us to build and how much to sell it for. Then we discovered Supercalc. All the things we liked about Visicalc are in it, and all the things we did not like are corrected. It addresses all the memory (256k), and in fact will address 512k if you have it. Now the offer. If you buy the package from us, the board and Supercalc, it will only cost you \$675. Look around. You don't have to take our word for it. But you should. The offer is only good if you buy them both at the same time.

#### FALLS LIKE A ROCK

Clever design, mass production, and the fact that we do it all on one board is how you get so much for so little.

We sell direct to you. No dealer or distributor profits are added on. And guess what else. If the prices of the most expensive components, the memory chips comes down, we will reduce our prices even more. Be sure to give us a call before you buy, you might be in for a pleasant surprise.

#### SATISFACTION GUARANTEED

Our warranty is 1 year parts and labor. We include the schematics with each board. We also sell diagnostics on diskette for \$10. We will repair any board returned for warranty repairs within 48 hours of receipt or we will give you a new board. And to top it off, if for any reason you are not satisfied, you may return the board to us within 30 days for a full refund. Period.

192k and Serial Port .....	\$499
64k more, add .....	\$100
Parallel printer port.....	\$50
Real time clock.....	\$50

California residents add 6½ % Sales Tax.

#### SHIPMENT

By UPS. We pay the freight.

#### PAYMENT

Cash, cashiers check, or money order. Visa and Mastercard accepted. Personal checks will require two weeks to clear.

#### TO ORDER

Outside California (800) 421-7103  
California (213) 870-3718

## QUBIE' DISTRIBUTING

1703 Stewart Street  
Santa Monica, CA 90404

Circle 494 on inquiry card.

Text box continued:

- If you can't swerve in time, it's best to blast incoming enemy rounds: photons cost you 10 mergs, but taking a hit costs 100 mergs (plus damage).

### Battle Techniques

- Note that your fired photons never go above the horizontal crosshair on your screen, so it seems advisable to keep Zylon ships below the crosshair too.
- Any hits that you receive toward the center of your screen seem to do much more damage than those on the periphery.

### Damaged Equipment

- Use the sector scanner only as a backup device for the times that your computer is out of commission. It takes too long to adjust your course by using the sector scanner; rather, learn to rely on the instruments and the attack-computer display.
- When your ion engines are damaged, note that the velocity indicator flickers between 0 and 12; if you then try to select a speed, the speed indicator flickers between 0 and 6. If you're going after a Zylon who damages your engines, don't touch the speed controls.
- Your hyperwarp engines can be used within a sector if your ion engines are damaged. Simply abort hyperwarp by selecting speed 0 when you get to where you want to go (you'll lose the speed advantage described above, and it'll cost 100 mergs to abort the hyperwarp).

### Videosyncrasies or Things That Happen but Shouldn't

- The animation slows for several seconds after an explosion; it may speed up at an inopportune moment. The effect is that your ship responds slowly as you try to line up on a Zylon, then, all of a sudden, his ship zips in and fires very quickly.
- When looking through an aft view, always turn toward incoming enemy rounds to avoid being hit.
- At the higher difficulty levels, some enemy rounds may seem to go by but still score damage.
- The tracking computer is a handy tool; learn to use it, but watch out: if you destory a Zylon in front of you after he has fired, the tracking computer will switch to aft view and the enemy round will score—learn to swerve if this happens.

### Further Fun

• It seems to help your cause if you call the Zylons by name. Suggestions are:

Vermin	Zyloons
Villains	Zyklowns
Nasties	Zylarks
Dastard	Hey You!

• If you think you're getting good at it, try playing Sudden Death (Warrior level with no shields).

*Damn the photons! Full speed ahead! . . . CPF*

## BYTE back issues for sale

	1976	1977	1978	1979	1980	1981	1982
Jan.				\$2.75	\$3.25	\$3.25	
Feb.			\$2.75	\$2.75	\$3.25	\$3.25	\$3.70
March			\$2.75		\$3.25	\$3.70	\$3.70
April			\$2.75	\$2.75	\$3.25	\$3.25	\$3.70
May		\$2.00	\$2.75	\$2.75	\$3.25	\$3.25	\$3.70
June		\$2.00	\$2.75	\$2.75	\$3.25	\$3.25	\$3.70

	1976	1977	1978	1979	1980	1981	1982
July	\$2.00	\$2.00	\$2.75	\$2.75	\$3.25	\$3.25	\$3.70
Aug.		\$2.00	\$2.75	\$2.75	\$3.25	\$3.25	\$3.70
Sept.		\$2.75	\$2.75	\$2.75	\$3.25	\$3.25	
Oct.			\$2.75	\$2.75	\$3.25	\$3.25	
Nov.		\$2.75		\$3.25	\$3.25	\$3.25	
Dec.		\$2.75	\$2.75	\$3.25	\$3.25	\$3.25	

Circle and send requests with payment to:  
**BYTE Magazine**  
 70 Maln St, Peterborough, NH 03458  
 Attn: Back Issues

The above prices include postage in the US. Please add \$1.00 per copy for Canada and Mexico; and \$2.00 per copy to foreign countries.

\*Payments from foreign countries must be made in US funds payable at a US bank.

\*Please allow 4 weeks for domestic delivery and 8 weeks for foreign delivery.

name \_\_\_\_\_

address \_\_\_\_\_

city \_\_\_\_\_ state \_\_\_\_\_ zip \_\_\_\_\_

# TECHNOLOGY ADVANCES

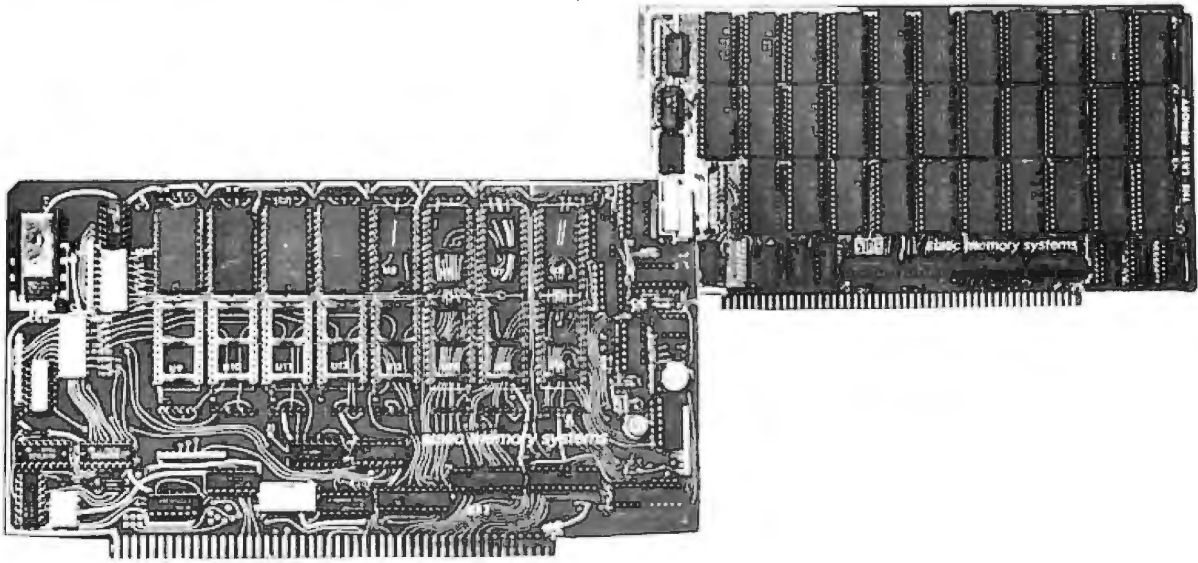

**THE LAST MEMORY™** is a high performance 64K memory module for 8 bit S100 systems. This board uses 16K byte-wide static RAM's which eliminate the timing and reliability problems associated with dynamic RAM boards. The 2K by 8 architecture of these RAM's allow high density and low power consumption, a characteristic not found in most static memories. This architecture also allows the use of 2716 type EPROM's in place of RAM IC's with no modification. As a result, this one board provides total system memory. **THE LAST MEMORY™** is available starting at less than \$100.00

**LASTING MEMORY™** is a combination EEPROM (Electrically Erasable PROM)/EPROM/RAM memory module for 8 bit S100 systems. This board includes an onboard EEPROM programmer which programs and erases 2816/2815 type EEPROM's with normal memory write instructions - no special software is required. Erasing and writing may be performed one byte at a time - no need to start over to make simple changes. Programming may be performed in any socket - EEPROM's can be tested and used without moving them. EEPROM's, 2716 type EPROM's, or 16K byte-wide static RAM's may be located in any of the 16 memory sockets for a total of 32K bytes of memory. **LASTING MEMORY™** is available at \$299.

The **VIB1™** is an intelligent I/O mapped CRT controller for use within S100 BUS (IEEE 696) systems. It incorporates all the video display capabilities of a stand-alone smart terminal. Some of its outstanding features include: 80 characters x 24 lines with an independent 25th line; full ASCII character set including control characters; graphics characters set; six visual attributes which can be used in combination; extensive screen editing and screen read capabilities. The **VIB1™** will be available in the 4th quarter 1982 at less than \$300.

**ideaLink™** is a high speed FSK modem which plugs into the S100 BUS (IEEE 696) and connects to a standard telephone in place of the handset. It is Bell 103/202 compatible offering both 300 Bps full duplex and 1200 Bps half duplex. All signal processing is performed digitally for long term reliability. **ideaLink™** will be available in the 4th quarter 1982 at less than \$300.



**static memory systems inc.**

401 State Bank Center  
Freeport, IL 61032 (815) 235-8713  
9 A.M. to 4 P.M. Mon. - Fri.

MC VISA accepted  
All prices net, FOB Freeport, IL  
OEM discounts available  
Dealer inquiries invited.

# McGraw-Hill Bookstore

Your Headquarters for Computer Books from All Publishers



**Microprocessor Development and Development Systems**

Miller Vis



**Just Released!**

**New Titles for the computer professional Now at The Professionals' Information Center**

- 1. Data Communications for Microcomputers** Practical Experiments for Z80 Based Microcomputers by Nichols, Nichols and Masson. Emphasis is on the practical! 352 pp. \$12.95 paper
- 2. Microprocessor Development and Development Systems** edited by Vincent Tseng. Written for professionals by specialists at TI, Motorola, Intel, Tektronix, HP etc. 224 pp. \$29.95
- 3. Teletext and Videotext in the United States: Technologies, Markets, and Public Policy Issues** by John Tydeman et al. Indispensable! 356 pp. \$34.95
- 4. Quality Assurance for Computer Software** by Dunn and Ullman. The answer to software development and maintenance problems. 352 pp. \$24.50
- 5. The Local Network Handbook** a Data Communications Book edited by G. R. Davis. Technology, software, equipment, implementation, applications, available products. 260 pp. \$26.95 paper
- 6. The Devil's DP Dictionary** by Stan Kelly-Bootle. A spoof dictionary based on the author's knowledge of computer technology and customs of the computer community. 160 pp. \$7.50 paper

**McGraw-Hill Bookstore**

1221 Avenue of the Americas, New York, New York 10020

Please send me the following:



of book # 1 2 3 4 5 6 copies BY9

Check or credit card: MasterCard  Visa  Amer Exp

Acct No. \_\_\_\_\_ Expires \_\_\_\_\_

Name \_\_\_\_\_

Address \_\_\_\_\_

City \_\_\_\_\_ State \_\_\_\_\_ Zip \_\_\_\_\_

Add applicable sales tax plus \$2.50 postage and handling for the first book, \$1.00 for each book thereafter.



Text continued from page 385:

from hits from enemy photons and using the twin ion engines. By far the most important of these is avoiding being hit by enemy photons. Each photon hit costs 100 mergs (energy units) and causes damage. Damage not only reduces your chances of survival, but certain kinds of damage will mean an unplanned trip to the nearest starbase for repairs. This extra trip could cost 300 to 800 mergs or more. Eight hundred mergs is equivalent to about eight final-score points, or the difference between ranks of Star Commander 1 and Star Commander 2.

The ion engines should seldom be needed in the enemy sector. As your ship comes out of hyperwarp and coasts to a stop, three different types of enemy movements will be found: ships with no movement, fast-moving ships that will seem to approach you but then retreat, and ships coming on at full-speed attack. Notice that ships within 120 metrons (distance units) will always attack, become visible, and be within photon range.

Don't trust your tracking computer to lock on to the nearest enemy vessel. If you are not immediately under attack when entering a sector, press M (the manual-tracking key) to avoid nasty surprises. If a ship is coming on at full speed, just wait for it. When a ship seems to be coming in for an attack, but then takes off in some other direction, don't chase it because that's the sucker move. Scan the sector for another ship to attack. If you have the time and patience and are willing to wait, the enemy will eventually come to you. (But don't forget that your starbase is under attack while you are waiting.) Early in the game at the Commander Level, you cannot afford to wait.

Contrary to what the user's manual tells you, speed 6 is not the most efficient way to use your ion engines. Energy requirements for shields, computers, and life-support systems must be accounted for during the journey. According to the manual, the energy drain for these systems is 2.75 mergs/centron (energy units per time unit). Although my tests show a lower energy consumption, the most efficient speed is actually 8 not 6. Figure 2 shows calculated and measured energy consumed for distances of 500 and 900 metrons. The calculated values are based on information taken from the user's manual. In either case, there is little difference in energy used for speeds above 7.

### Engaging the Enemy

As you come out of hyperwarp and coast to a stop, you will often find yourself overrunning an enemy ship and being fired on before you are ready to defend yourself. Try this! As the ship comes within about 150 to 200 metrons, throw your ship into a hard turn in either direction. Hold the turn until the enemy has passed all the

# H & E COMPUTRONICS INC.

•• EVERYTHING FOR YOUR TRS-80™ • ATARI™ • APPLE™ • PET™ • CP/M™ • XEROX™ • IBM™ • OSBORNE™ ••

\* TRS-80 is a trademark of the Radio Shack Division of Tandy Corp \* ATARI is a trademark of Atan Inc \* APPLE is a trademark of Apple Corp \* PET is a trademark of Commodore \* CP/M is a trademark of Digital Research \* XEROX is a trademark of Xerox Corp \* IBM is a trademark of IBM Corp \* OSBORNE is a trademark of Osborne Corp



## BUSINESS PAC 100

### 100 Ready-To-Run Business Programs

\* All orders processed within 24-Hours  
\* 30-Day money back guarantee

(ON CASSETTE OR DISKETTE).....Includes 128 Page Users Manual.....  
Inventory Control.....Payroll.....Bookkeeping System.....Stock Calculations.....  
Checkbook Maintenance.....Accounts Receivable.....Accounts Payable.....

#### BUSINESS 100 PROGRAM LIST

NAME	DESCRIPTION		
1 RULE78	Interest Apportionment by Rule of the 78's	59 WACC	Weighted average cost of capital
2 ANNU1	Annuity computation program	60 COMBAL	True rate on loan with compensating bal. required
3 DATE	Time between dates	61 DISCBAL	True rate on discounted loan
4 DAYYEAR	Day of year a particular date falls on	62 MERGANAL	Merger analysis computations
5 LEASEINT	Interest rate on lease	63 FINRAT	Financial ratios for a firm
6 BREAKEVN	Breakeven analysis	64 NPV	Net present value of project
7 DEPRSL	Straightline depreciation	65 PRINDLAS	Laspeyres price index
8 DEPRSY	Sum of the digits depreciation	66 PRINDPA	Paasche price index
9 DEPRDB	Declining balance depreciation	67 SEASIND	Constructs seasonal quantity indices for company
10 DEPRDDB	Double declining balance depreciation	68 TIMETR	Time series analysis linear trend
11 TAXDEP	Cash flow vs. depreciation tables	69 TIMEMOV	Time series analysis moving average trend
12 CHECK2	Prints NEBS checks along with daily register	70 FUPRINF	Future price estimation with inflation
13 CHECKBK1	Checkbook maintenance program	71 MAILPAC	Mailing list system
14 MORTGAGE/A	Mortgage amortization table	72 LETWRT	Letter writing system-links with MAILPAC
15 MULTMON	Computes time needed for money to double, tripe, etc	73 SORT3	Sorts list of names
16 SALVAGE	Determines salvage value of an investment	74 LABEL1	Shipping label maker
17 RRVARIN	Rate of return on investment with variable inflows	75 LABEL2	Name label maker
18 RRCONST	Rate of return on investment with constant inflows	76 BUSBJD	DOME business bookkeeping system
19 EFFECT	Effective interest rate of a loan	77 TIMECLCK	Computes weeks total hours from timeclock info.
20 FVAL	Future value of an investment (compound interest)	78 ACCTPAY	In memory accounts payable system-storage permitted
21 PVAL	Present value of a future amount	79 INVOICE	Generate invoice on screen and print on printer
22 LOANPAY	Amount of payment on a loan	80 INVENTZ	In memory inventory control system
23 REQWITH	Equal withdrawals from investment to leave 0 over	81 TELDIR	Computerized telephone directory
24 SIMPDISK	Simple discount analysis	82 TIMUSAN	Time use analysis
25 DATEVAL	Equivalent & nonequivalent dated values for oblig	83 ASSIGN	Use of assignment algorithm for optimal job assign.
26 ANNUDEF	Present value of deferred annuities	84 ACCTREC	In memory accounts receivable system-storage ok
27 MARKUP	% Markup analysis for items	85 TERMPAY	Compares 3 methods of repayment of loans
28 SINKFUND	Sinking fund amortization program	86 PAYNET	Computes gross pay required for given net
29 BONDVAL	Value of a bond	87 SELLPR	Computes selling price for given after tax amount
30 DEplete	Depletion analysis	88 ARBCOMP	Arbitrage computations
31 BLACKSH	Black Scholes options analysis	89 DEPRSF	Sinking fund depreciation
32 STOCVAL1	Expected return on stock via discounts dividends	90 UPSZONE	Finds UPS zones from zip code
33 WARVAL	Value of a warrant	91 ENVELOPE	Types envelope including return address
34 BONDVAL2	Value of a bond	92 AUTOEXP	Automobile expense analysis
35 EPSEST	Estimate of future earnings per share for company	93 INSFIL	Insurance policy file
36 BETAALPH	Computes alpha and beta variables for stock	94 PAYROLL2	In memory payroll system
37 SHARPE1	Portfolio selection model-i.e. what stocks to hold	95 DILANAL	Dilution analysis
38 OPTWRITE	Option writing computations	96 LOANAFFD	Loan amount a borrower can afford
39 RTVAL	Value of a right	97 RENTPRCH	Purchase price for rental property
40 EXPVAL	Expected value analysis	98 SALELEAS	Sale-leaseback analysis
41 BAYES	Bayesian decisions	99 RRCONVBD	Investor's rate of return on convertible bond
42 VALPRINF	Value of perfect information	100 PORTVAL9	Stock market portfolio storage-valuation program
43 VALADINF	Value of additional information		
44 UTILITY	Derives utility function		
45 SIMPLEX	Linear programming solution by simplex method		
46 TRANS	Transportation method for linear programming		
47 EOQ	Economic order quantity inventory model		
48 QUEUE1	Single server queueing (waiting line) model		
49 CVP	Cost-volume-profit analysis		
50 CONDPFOT	Conditional profit tables		
51 OPTLOSS	Opportunity loss tables		
52 FQJQOQ	Fixed quantity economic order quantity model		
53 FQEQWSH	As above but with shortages permitted		
54 FQEQGPB	As above but with quantity price breaks		
55 QUEUECB	Cost-benefit waiting line analysis		
56 NCFANAL	Net cash-flow analysis for simple investment		
57 PROFIND	Profitability index of a project		
58 CAPI	Cap. Asset Pr. Model analysis of project		

- TRS-80 Cassette Version \$99.95
- TRS-80 (Mod-I or III), Pet, Apple or Atari Versions \$99.95
- TRS-80 Mod-II, IBM, Osborne and CP/M Versions \$149.95

ADD \$3.00 FOR SHIPPING IN UPS AREAS  
ADD \$4.00 FOR C.O.D. OR NON-UPS AREAS  
ADD \$5.00 TO CANADA AND MEXICO  
ADD PROPER POSTAGE OUTSIDE OF U.S., CANADA AND MEXICO

**COMPUTRONICS**  
MATHEMATICAL APPLICATIONS

50 N. PASCACK ROAD  
SPRING VALLEY, NEW YORK 10977

ASK FOR OUR 64-PAGE CATALOG  
DEALER INQUIRIES INVITED

**NEW TOLL-FREE ORDER LINE**  
(OUTSIDE OF N.Y. STATE)  
**(800) 431-2818**

**24 HOUR ORDER LINE**  
**(914) 425-1535**



ALL PRICES & SPECIFICATIONS SUBJECT TO CHANGE  
DELIVERY SUBJECT TO AVAILABILITY

# CHIPS & DALE

THE INFLATION FIGHTERS!

\*\*\*SPECIAL\*\*\*

- |                                     |   |
|-------------------------------------|---|
| 4116 250ns 8/19.50 100 + \$1.05 ea. | *1791 Disk Controller \$16.50           |
| 4116 200ns 8/11.00 100 + \$1.18 ea. | *Z80A CPD \$3.00                        |
| 4116 150ns 8/14.50 100 + \$1.50 ea. | 0251A \$4.00 ea.                        |
| 4116 120ns 8/16.50 100 + \$1.80 ea. | 2716-1 (5V)350ns 8/15.50 ea. \$6.25 ea. |
| 2114L 300ns 8/13.00                 | 2716 (5V)450ns 8/17.75 ea. \$4.00 ea.   |
| 2114L 200ns 8/14.75                 | *2732 (5V)450ns 8/17.25 ea. \$9.00 ea.  |
| *4164 200ns 6/3.95 100 + \$6.25     | 2332 (5V)450ns 8/17.25 ea. \$9.00 ea.   |
| *4164 150ns \$7.95 ea. 100 + CALL   | 27645V 300ms 28 pin \$20.00 ea.         |
| *6118 150ns \$6.75 100 + CALL       |   |
| *6116 200ns \$5.25                  |   |

## COMPUTERS

	Sugg. Hlts	C&D
NEC P.C. 8000		
8001 Comp 32K	\$995.00	\$715.00
8012 I/O unit	\$649.00	\$475.00
8031 Dual Modem unit	\$995.00	\$715.00
Other NEC Products	CALL	—
Altos Computers	CALL	—
Eagle II	\$2995.00	CALL
Eagle III	\$3995.00	CALL
Sege II (16 bit)	CALL	CALL
IBM P.C. complete sys (with or w/out hard disk)	CALL	CALL

## PRINTERS

Epson MX80 Graphix Plus	—	CALL
Epson MX80 FT Graphix Plus	—	CALL
Epson MX100 Graphix Plus	—	\$645.00
NEC Printer P.C. 8023	\$695.00	\$465.00
Other NEC Printers	—	CALL
Okidata Printers		
82A	\$748.00	\$397.00
83A	\$895.00	\$645.00
84A	\$1395.00	CALL
PACEMARK 2350	\$2800.00	\$2200.00
Smith-Corona Printers TP-1	\$895.00	CALL
Dialble Printers 630 (R102)	\$2710.00	\$1989.00
ProWriters Starwriter Printmaster	—	CALL
C Non Printers	—	CALL

## SOFTWARE CP/M, IBM, Apple, TRS-80, Atari

Package 1 includes Wordstar, Mail Merge, Spellstar (CP/M)	\$350.00
Package 2 includes Data Star, Calculator, Supervisor (CP/M)	\$350.00
dBase II (CP/M)	\$465.00
TRS 80 (CP/M)	\$397.00
CALL for other mfg. comp., print, modems, terminals, chips, & software	

Allow up to 3 wks. for personal checks to clear. Please include phone number. Prices subject to change without notice. Shipping & Handling for Chips \$3.50, FOB Bellevue, WA. for all else. Wash. residents add 6.5% Sales Tax.

**CHIPS & DALE**  
10655 N.E. 4th St., Suite 400  
Bellevue, WA 98004  
1-206-451-9770



2a

ENERGY CONSUMED VS. SPEED OVER A DISTANCE OF 500 METRONS

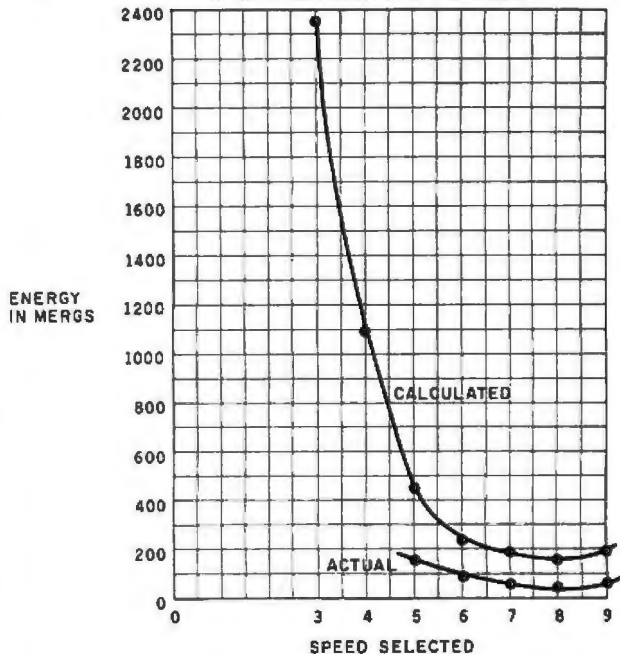

## \*\* S-100 \*\* USED COMPUTERS AND PERIPHERALS

- Digital Systems Dual 8" floppy interface ..... \$35
  - IMSAI PIO two-port parallel board ..... 60
  - MITS 88-4 PIO (four ports) ..... 75
  - Spacebyte 8085 CPU Board ..... 75
  - Wamco 8080 Processor Board ..... 60
  - 17 Slot Processor Tech Motherboard (empty w/cardguides) 40
  - Altair 8800b 18 slot ..... 220
  - Rainbow 2000 Color graphics board ..... 125
  - Morrow triple cassette controller ..... 70
  - Black and White graphics board ..... 55
  - Two 8" Single/Single Calcomp Drives w/docs ..... 350
  - Two Black and White 22MHz video monitors ..... 90
  - 22 Slot motherboard 11 connectors active term. .... 50
  - Linear Power supply 8V/15A + - 14V/2A ..... 35
  - MERLIN Graphics Board with software and docs ..... 120
  - IMSAI VIO/C Video Board 80 by 24 ..... 100
  - Cromemco 4FDC disk controller with CDOS ..... 250
  - Two 32K IMSAI Memory boards 1 with 32K, 1 with 24K .. 250
  - MEK6800 evaluation system w/8K, and docs ..... 125
  - Autocontrol single board CP/M system, 10 MHz with power supply and two 8" Double sided/Double density MPI drives ..... negot. 2400
  - Western Digital Pascal Microengine w/UCSD Pascal and two 8" drives ..... 2000
  - Shaffstall EDI7700 phototypesetter floppy disk interface for use with Compugraphic Editwriter series typesetting equipment, with standard ASCII translation software. Excellent condition. .... 8500
  - Three SCION word processing subsystems complete with keyboard, monitor, S-100 display board, and Wordsmith editing software ..... 1200 ea. or 3/3000
- Documentation is available for equipment.  
Prices are FOB Peterborough, NH  
Call or write Jon Swanson, c/o BYTE, 70 Main Street, Peterborough, NH 03458 (603) 924-9281.

2b

ENERGY CONSUMED VS. SPEED OVER A DISTANCE OF 900 METRONS

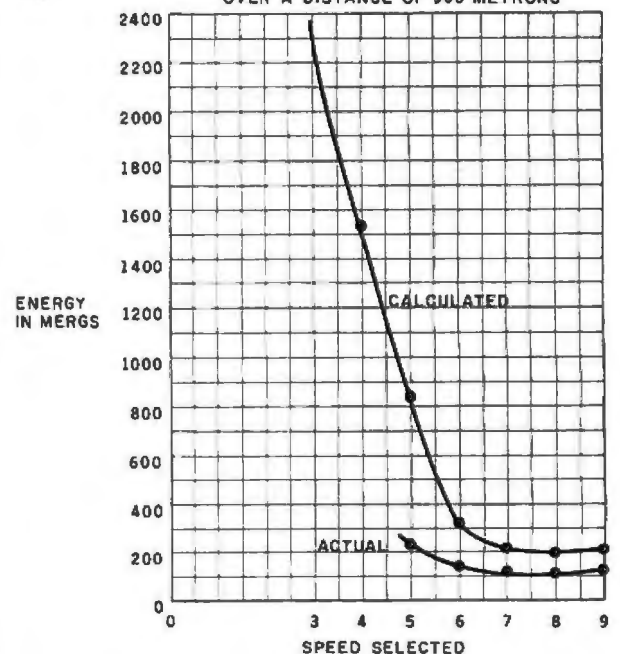

Figure 2: Energy expended for ion engine use. Contrary to the figures in the user's manual, selected-speed 8 is most efficient when other systems are also drawing energy. Figure 2a shows the energy expended at a variety of speeds over 500 metrons. Figure 2b shows the corresponding values for a distance of 900 metrons.



The DSI-A506 provides 5 MB formatted (6 MB unformatted) storage for only \$1995. The DSI-A514 provides 12 MB formatted (14 MB unformatted) storage for just \$2695\*.

# \$1995\* HARD DISK EXPANSION FOR THE APPLE II<sup>®</sup>

**Supports Apple DOS 3.3<sup>®</sup>, Apple Pascal<sup>®</sup>, and CP/M<sup>®</sup>. Intermixed.** You can even allocate storage for all three systems on one hard disk, and transfer files easily from one system area to another. The Davong system reformats the transferred file automatically.

**Boots from hard disk**, to save time when bringing up a different system.

**Expand your Apple II for a lot less money.** Take this ad to your local computer retailer and ask for products by Davong.

\*Manufacturer's suggested retail price. Includes all required components.

Apple II, Apple DOS 3.3 and Apple PASCAL are registered trademarks of Apple Computer Corporation.  
CP/M is a registered trademark of Digital Research Corporation

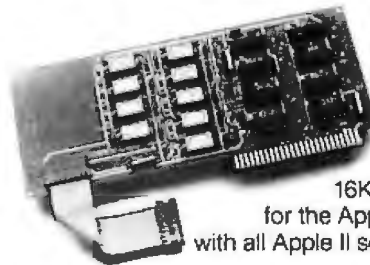

**16K RAM for just \$99\*.** Davong Systems also offers the DSI-A16—a 16K RAM expansion card for the Apple II. Fully compatible with all Apple II software and hardware.

**DAVONG Systems, Inc.**

*Expand your personal computer for a lot less money.*

1061 Terra Bella Avenue  
Mountain View, CA 94043 (415) 965-7130

Priority	Name	If Damaged	If Destroyed
1	shields	hyperwarp at once	hyperwarp at once
2	photons	finish sector if even odds	hyperwarp at once
3	computer and sector scan	finish sector if even odds	hyperwarp at once
4	subspace radio	_____	finish sector
5	computer	continue	finish sector
6	engines	continue	continue
7	sector scan	continue	continue

**Table 1:** Damage priorities determine when to leave for repairs immediately. In the chart, "finish sector" means wait until you have disposed of all the Zylons in the sector before hyperwarping to a starbase; "finish sector if even odds" means go for repairs immediately unless there is only one Zylon in the sector. If more than one piece of equipment is damaged, follow instructions for the highest-priority item.

way behind you and is coming around the front again. Watch your instruments. By this time the screen will have stopped flashing, and you will be ready to fight with no distractions.

As the enemy approaches from the front, maneuver your joystick to keep him off to the side and low. The idea is, of course, to avoid photon hits and damage as he approaches. When the enemy is about 20 metrons away, swing him into your sights and blow him away. Conserve your photons—they cost energy too. Don't let the Zylon get much closer than 20 metrons before using this maneuver, because he just might zip around behind you. If two ships are attacking from the front at once, concentrate on the one closer to the center of the screen.

A word about attacks from the rear: for several weeks I tried to handle aft attacks without much success. If you can handle a frontal attack one second and an aft barrage the next (with all your joystick movements reversed), that's great; but I've found that you can still reach Star Commander 1 without mastering the aft attack. To bring an aft-attacking enemy to the front, just throw your ship into a hard spin and he will wind up in front of you. You will notice that you are almost never hit while in a spin.

The toughest situation is simultaneous front and aft attacks. You can quickly turn off autotracking (press T) to concentrate only on the front. I've already suggested how to handle frontal attacks, but in this situation throw in a small amount of back and forth joystick movement. This hurts the aim of the aft attacker.

**Necessary Capabilities**

How do you know when to cut and run? For some kinds of damage, there is no doubt. Some systems, however, are more important than others, so the decision is not clear cut. Table 1 is presented for your use as a guide only. Many other damage combinations are possible and are left to your judgment, skill level, and the game situation. To help explain the chart, here are some examples:

- In a case where your photons are damaged, finish the sector if only one enemy ship remains and then go to the nearest starbase for repairs. If you are outnumbered, leave the sector immediately.
- In a case where your computer and the sector-scan systems are damaged and your ion engines are destroyed, finish the sector if you are faced with only one Zylon, then go for repairs.

A final hint: your subspace radio is much more important early in the game than it is later when enemy ship movements are not as threatening.

What I've described here is just about all I know about Star Raider. I hope these suggestions will be helpful to your pursuit of new and better ranking and many more hours of enjoyment. ■

**YOU'VE JUST FOUND  
THE MISSING LINK!**



Computer Shopper is your link to individuals who buy, sell and trade computer equipment and software among themselves nationwide. No other magazine fills this void in the marketplace chain. Thousands of cost-conscious computer enthusiasts save by shopping in Computer Shopper every month through hundreds of classified ads. And new equipment advertisers offer some of the lowest prices in the nation. Computer Shopper's unbiased articles make for some unique reading among magazines and there's a "help" column to answer difficult problems you may have with interfacing, etc. For a limited time you can subscribe to Computer Shopper with a 6 month trial for only \$6 or 12 months for only \$10. MasterCard & VISA accepted.

**6 month trial, \$6 or 12 months for only \$10**

**COMPUTER SHOPPER**  
P.O. Box F-304 • Titusville, FL 32780  
305-269-3211



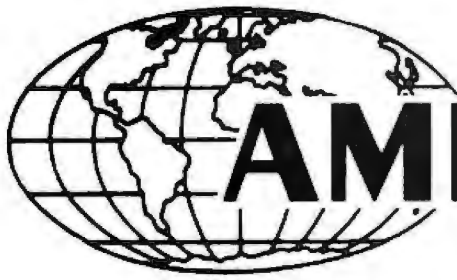

# AMERICAN

# SMALL BUSINESS COMPUTERS

118 SO. MILL ST  
PRYOR, OK 74361  
(918) 825-4844

ALL PRICES ARE CASH DISCOUNTED 3% C O D AND CHARGE ORDERS ARE 3% MORE  
RETAIL LOCATION 447 S WOOD, PRYOR, OKLAHOMA 74361

# TRS-80 MODEL III

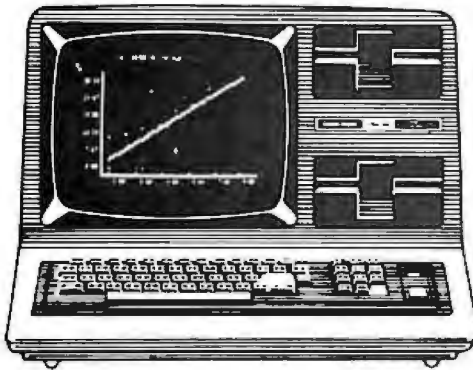

**16K.....\$825**

**48K.....\$849**

**48K 1 DRIVE.....\$1499**

**48K 2 DRIVE.....\$1749**

**RS-232 (INSTALLED).....\$92.00**

**CASSETTE.....\$55.00**

## THERE'S NO SECRET

There's no secret as to why we can sell TRS-80 computer equipment for less. Low overhead — that's the reason — pure, simple and straight! As everyone knows, Radio Shack is a huge corporation...with huge expenses. We are able to buy the bare-bones computers from Radio Shack. To these computers, we add our own memory chips, disk drives, cables, etc. The result is a computer system which is equal to, or in many cases, superior to the one you would get from Radio Shack in both price and performance capabilities. There is one thing that you don't get from Radio Shack — their 90 day warranty. What you get in its place is the exclusive 180 days American Small Business Computer's Warranty. So...if you like the Radio Shack computer, but don't like the price...CHECK US OUT!!!

American Small Business Computers is not an authorized Radio Shack Dealer. We do not offer a Radio Shack 90 Day Warranty on our computers. Instead, we offer the American Small Business Computers 180 Day Warranty. If you have a problem with your computer, return it to us for about 48 hours. If we can't fix it, we'll replace it!

## 918-825-4844

# Model III A to D Revisited

*Build this simple and inexpensive analog-to-digital converter.*

---

William Barden Jr.  
28122 Orsola  
Mission Viejo, CA 92692

---

In an earlier article in this series (January 1982 BYTE, page 160) I described a joystick controller for the Model III that was also an analog-to-digital converter (ADC). In this article, I'll show you a much neater implementation of an ADC—one that uses only three chips and can be hooked directly to the cassette port of the Model III, eliminating a great deal of wire-wrapping and connector preparation. In fact, you can use this ADC with the existing cassette cable that plugs into the 5-pin DIN jack on the back of the Model III.

This ADC is also a little bit better than the earlier version. It's exactly 1 bit better: it will convert an analog voltage to 7-bit resolution, instead of 6 bits. In addition, this ADC is extremely accurate, down to about 20 millivolts (mV) for a 2.5 volt (V) range. In fact, if you buy this circuit tonight, I can make you a special deal. . . .

One disadvantage, however, is that this ADC will allow only a half dozen or so samples per second. This is no detriment, though, if you are moni-

---

## About the Author

William Barden Jr. has written many books on microcomputer programming and design, including *Microcomputer Math*.

---

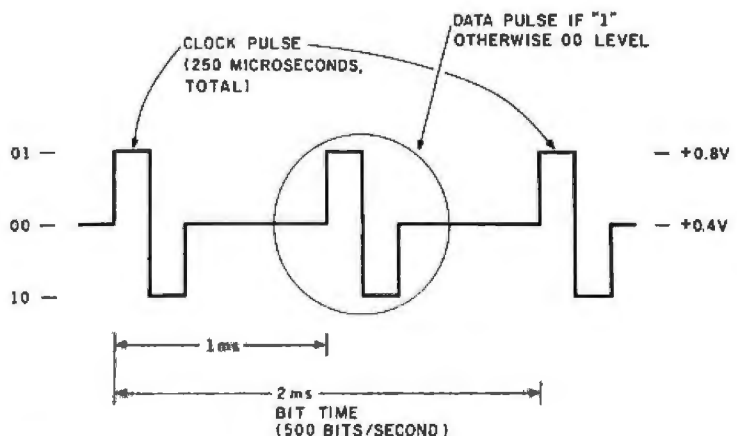

Figure 1: The 500-bps tape format of the Model III (and Model I) uses a clock pulse and data pulse for each data bit. The data pulse is absent for a 0 bit.

toring slowly changing real-world events such as temperature, pressure, or ambient light.

## Model III Cassette Port

I've described the Model III cassette port in other articles, but it probably won't hurt to review the circuits rapidly.

The Model III is capable of writing data on cassette tape in either 500- or 1500-bit-per-second (bps) format. The same circuitry is used for 500- and 1500-bps output, but the resultant tape formats are different.

The 500-bps tape format is shown in figure 1. Each bit time is made up of a leading clock pulse followed by a second pulse for a 1 or no pulse for a 0. The duration of each pulse is about 250 microseconds ( $\mu$ s), top and bottom.

The 1500-bps tape format is shown in figure 2. Here, the format is that of "frequency-shift keying," one frequency for a 0 and a second frequency for a 1 bit.

Both formats use software that drives a simple circuit to produce three voltage levels (only the two ex-

# Marcey Inc. Introduces...



The High Performance Business Computer That Is  
**HERE TODAY** and **HERE TOMORROW**

The SYSTEM 2100 is a complete microcomputer system utilizing the latest in S-100 technology. It is ready to use in your business **TODAY** - and can expand to fill your needs **TOMORROW**.

The SYSTEM 2100 includes:

- Dual Processor  
8085A - 8 bit 7 MHz  
8088 - 16 bit 8 MHz
- Meets IEEE 696/S-100 Specifications
- Dual 8" Double-Sided Double Density Floppy Discs  
2.2 Megabyte Capacity
- CP/M 80 & CP/M 86 Included
- Terminal & Printer Included
- 100K Bytes **Static** Ram
- Real time Clock w/Battery Backup
- High Speed DMA Disk Controller
- Attractive Designer Desk

## List Price \$9995.00

Dealer Inquiries Invited    Quantity Pricing Available

# MARCEY INC.

5848 Sepulveda Blvd. Van Nuys, California 91411 (213) 994-2533

For Further Information Circle Reader Card # 282

# ELCOMP BOOKS and SOFTWARE

For ATARI-PET-OSI-APPLE II-6502-VIC-20-Sinclair-Times

- Dealers welcome!**
- ATARI ATARI ATARI ATARI**
- ATARI BASIC - Learning by Using**  
This new book is an "Action" book. You do more than read it. Learn the intricacy of ATARI-BASIC through the short programs which are provided. The suggestions challenge you to change and write program routines. Yes, it's exciting - Many of the programs are appropriate for beginners as well as experienced computer users. (Screen Drawings, Special Sounds, Keys, Paddles & Joysticks, Specialized Screen Routines, Graphics and Sound, Peeks and Pokes and special stuff!).  
Order-No. 164 \$3.95
- ATARI Learning by Using - Book + cassette or disk**  
This package includes the book No. 164 plus a cassette or disk (please specify) containing a variety of the programs which are listed in the book.  
Order-No.: 7220 \$39.95
- Games for the ATARI-Computer**  
How to program your own games on the ATARI. Complete listings in BASIC and Machine Language of exciting games Tricks and hints.  
Order-No. 162 \$7.95
- GAME PACKAGE for the ATARI**  
Book + cassette or disk  
Includes the book No. 162 plus cassette or disk (please specify) containing a variety of the programs listed in the book.  
Order-No. 7221 \$39.95
- ATMONA-1**  
Machine Language Monitor for the ATARI 400/800.  
This powerful monitor provides you with the firmware support that you need to get the most out of your powerful system. ATMONA-1 comes on a bootable cassette. No cartridges required. Disassemble, Memory Dump HEX & ASCII, Change Memory Locations, Blocktransfer, fill memory block, save and load machine language programs, start mach Lang Progr. (Printer optional).  
Comes with introductory article on how to program the ATARI computer in machine language. (Available also in ROM)  
Order-No. 7022 \$19.95
- ATMONA-2 Superstepper**  
A very powerful Tracer to explore the ATARI ROM/RAM area. Stop at previously selected address. Opcode or operand (cassette).  
Order-No. 7049 \$49.95
- EDITOR/ASSEMBLER for ATARI 800, 32K or 48K RAM**  
Extremely fast and powerful Editor/Assembler. (8K Sourcecode in about 5 seconds) Includes ATMONA-1.  
Order-No. 7098 \$49.95
- MACRO-Assembler for ATARI 800, 48K RAM**  
Please specify your system, RAM, disc or cassette.  
Order-No. 7099 \$89.00  
Add \$39.00 for cartridge version
- Gunfight - For ATARI 400/800**  
16K RAM, needs two joysticks, animation and sound (8K machine language).  
Order-No. 7207 \$19.95
- Birth control with the ATARI**  
(Knaus Ogino) Cass. or disk  
Order-No. 7222 \$29.95
- Astrology and Biorhythm for ATARI**  
Cass. or disk.  
Order-No. 7223 \$29.95
- EPROM Cartridge KIT for ATARI**  
Cartridge (bare board) with instructions (holds two 16K or two 32K EPROMs) (2716,2532,2732)  
Order-No. 7224 \$19.95  
Order-No. 7043 complete \$29.95
- Invoice Writing for small business with ATARI 400/800**  
16K RAM.  
Order-No. 7022, cass. \$29.95  
Order-No. 7200, disc. \$99.99
- Mailing-List No. 7213 \$24.95**  
**Inventory Contr. No. 7215 \$24.95**
- NEW I/TEXT-1**  
This new wordprocessor in machine language (8K) for all ATARI 400/800 computers offers the best price performance ever. 23 editor control commands, 17 formatting commands, dynamic formatting Vertical and horizontal scrolling (up to 255 char. per line) include command on disk!  
Order-No. 7210 cassette \$29.95  
Order-No. 7211 disk \$39.95  
Order-No. 7212 cartridge \$79.00
- Learn FORTH for the ATARI 400/800**  
cassette or disk  
Order-No. 7053 \$19.95
- ELCOMP FORTH - Enhanced FIG-FORTH on disk only.**  
Order No. 7055 \$39.95
- How to connect your EPROM-Printer to the ATARI 400/800.**  
Construction article with printed circuit board and software. (Screenprint and variable characters per line).  
Order-No. 7210 \$19.95
- OSI OSI OSI OSI OSI**
- The First Book of Ohio Scientific**  
Introduction to OSI computers. Diagrams, hardware and software information not previously available in one compact source. 192 pages.  
Order-No. 157 \$7.95
- The Second Book of OHIO**  
Order-No. 158 \$7.95
- The Third Book of OHIO**  
Order No. 159 \$7.95
- The Fourth Book of OHIO**  
Order-No. 160 \$9.95
- VIP Package - Above book plus a cassette with the programs**  
Order-No. 160A \$19.95
- The Fifth Book of OHIO**  
Order-No. 161 \$7.95
- Invoice Writing Program for OSI.**  
C1PMF, CAP Disk and Cassette, 8K RAM.  
Order-No. 8234 \$29.90
- Mailing List for C1PMF or CAPMF 24K RAM**  
250 addresses incl. phone number and parameters on one 5 1/4 disk  
Order-No. 8240 \$29.90
- 8K Microsoft BASIC Ref. Man.**  
Order-No. 161 \$9.95
- Expansion Handbook for 6502 and 8802**  
Order-No. 162 \$9.95
- Microcomputer Appl. Notes**  
Order-No. 163 \$9.95
- Complex Sound Generation**  
Now revised applications manual for the Texas Instruments SN 76477 Complex Sound Generator.  
Order-No. 164 \$6.95
- Small Business Programs**  
Complete listings for the business user, inventory, invoice writing, Mailing List and much more. Introduction to Business Applications.  
Order-No. 168 \$14.90
- Microcomputer Hardware Handbook (845 pages)**  
Descriptions, pinouts and specifications of the most popular microprocessor and support chips. A MUST for the hardware buff.  
Order-No. 29 \$14.95
- Care and Feeding of the Commodore PET**  
Eight chapters exploring PET hardware. Includes repair and interfacing information. Programming tricks and schematics.  
Order-No. 150 \$9.95
- Prototype-Expansion Board for VIC-20 (S-44-Buil).**  
Order-No. 4844 \$18.95
- Wordprocessor for VIC-20, 8K RAM**  
Order No. 4870 \$18.95
- Mailing List for VIC-20, 16K RAM**  
Order No. 4683 \$14.95
- Tricks for VICs - The Victory Programs**  
hints and expansion information for VIC-20  
Order No. 141 \$9.95
- TIC TAC VIC**  
Order No. 4880 \$9.95
- GAMERACK I (3 Games)**  
Order No. 4881 \$14.95
- Dual Joystick Instruction**  
Order No. 4885 \$9.95
- INPUT/OUTPUT Programming with your VIC**  
Order No. 4886 \$9.95
- 16K RAM/ROM board for S44-bus.**  
Any combination of RAM and ROM on one board. (SY2128 or 2716)  
Order-No. 813 \$39.95
- Low cost expansion boards for your APPLE II.**  
Bare board comes with extensive description and software.  
6522 VIA-I/O Exp. Order-No. 806 \$39.00  
2716 EPROM-Burner Order-No. 807 \$49.00  
8K EPROM/RAM Card Order-No. 808 \$29.00
- Software for SINCLAIR ZX-81 and TIMEX 1000**  
Machine Language Monitor Order No. 2309 \$9.95
- Mailing List**  
Order No. 2308 \$19.95
- Programming in BASIC and machine language with the ZX-81(82) or TIMEX 1000.**  
Order No. 140 (book) \$9.95

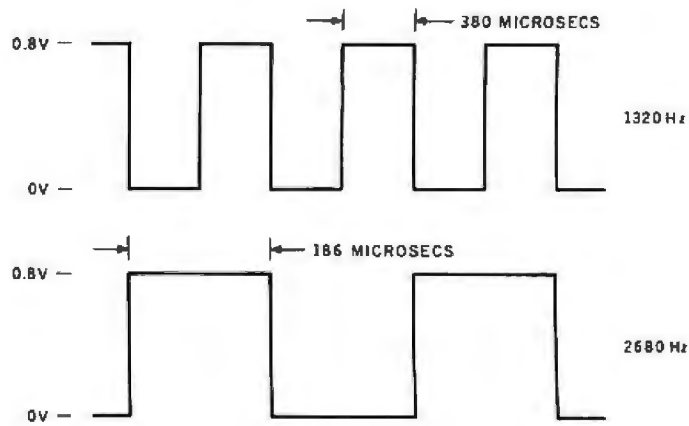

Figure 2: The 1500-bps tape format for the Model III uses a frequency-shift-keying technique. Two frequencies are used to represent 0s or 1s.

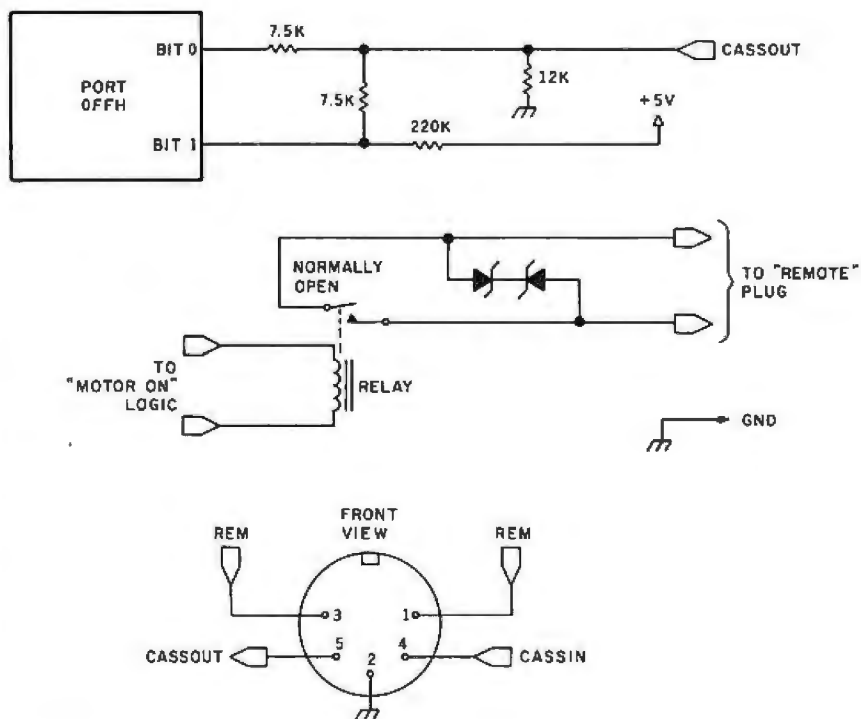

Figure 3: The Model III cassette output logic uses a simple two-bit latch to generate three analog levels that are used to write to cassette tape.

tremes are used for 1500 bps): 0 V, .46 V, and .85 V. (See figure 3.) The levels are produced by outputs to a 2-bit latch with input/output port address hexadecimal FF. The latch simply records the two least significant bits sent to I/O address FF. If a binary xxxxxx00 is output, a .46-V level is produced. Binary xxxxxx01 produces a .85-V level, and xxxxxx10 produces

a 0-V level (x indicates that the value of a particular digit is insignificant).  
Toggling the latch bits in an assembly-language program can produce any square wave output of any frequency, up to the limits of the electronics in the cassette circuitry. Unfortunately, this action must be in assembly language, by the Z80 instruction OUT (OFFH), because

# TCS MODEL III 48k 2 DISK



Fully assembled and tested systems that are software compatible and functionally identical to Radio Shack units sold at computer centers for Shundreds more. Includes DOSPLUS 3.3

- CONTROLLER BOARDS are high quality double sided epoxy boards with gold plated contacts.
- POWER SUPPLY is the finest switching type available.
- MOUNTING HARDWARE includes power and data cables.
- DISK DRIVES are Tandon, the same ones used by Radio Shack - 40 track, double density, 5 millisecond stepping rate

The System comes with 180 day TCS limited warranty. **\$1795**

### Model III 48k 2 Drive System \$2095

720,000 bytes of storage. TCS uses 2 dual sided 40 track Tandon drives. You can convert your existing 40 track standard diskettes. Includes full DOSPLUS 3.4 & manual.

## MODEL III DISK EXPANSION KITS

1 Controller, Power Supply, Mounting Hardware & Instructions	\$379
2 Controller, Power Supply, Hardware & one 40 track Tandon drive	\$577
3 Controller, Power Supply, Hardware, two 40 track Tandon drives, 32k memory (everything you need for 2 drive 48k upgrade)	\$799
3a Kit 3 but with two 80 track drives (dual sided 40s)	\$999
4 Tandon 40 track disk drive (bare drive only, no instructions)	\$199
4a Kit 4 but with Configuration Instructions & Power Cable	\$219
5 16k of high quality TCS memory	\$39
5a 16k of RS memory	special \$79
6 32k of high quality TCS memory	\$89
6a 32k of RS memory	special \$158
7 Disk Controller Board (supports 40/80 single/double sided drives)	\$249
8 Switching Power Supply for Controller & two drives	\$119
9 Hardware & Cabling kit for above components	\$89

## PRINTERS & ACCESSORIES

### MATRIX PRINTERS

LINE PRINTER VII RS	\$325
NEC 8023A	\$495
C. ITOH 8510	\$495
OKIDATA 82A	\$499
OKIDATA 82A w/tractor	\$559
OKIDATA 83A	\$769
LINE PRINTER VIII RS	\$649
CENTRONICS 739 parallel	\$599
CENTRONICS 739 serial	\$749
OKIDATA 84 / 200 cps	\$1295
LINE PRINTER VI RS	\$988
CENTRONICS 704	\$1559
ANADIX 9500/01 2k buf.	\$1295
TEXAS INST. 810 Basic	\$1595
LINE PRINTER V RS	\$1549
Centronics 352 / 200 cps	\$1795
Centronics 353 / dual mode, 200cps data proc., 50cps super letter quality	\$2495

### LETTER QUALITY

#### Delay Wheel / Spinwriters

C. ITOH F-10 / 40 cps	\$1595
DAISY WHEEL II RS	\$1695
SMITH CORONA TP-1	\$699
BROTHER/COMREX High quality . . . Low price	\$849
NEC SPINWRITERS	\$CALL

### LINE PRINTERS

CENTRONICS 6080/81 600 lines per minute	
6081 standard	\$6399
6080 quietized cabinet	\$7676

## EPSON . . . . \$CALL

EPSON MX80  
EPSON MX80 FT  
EPSON MX100 FT

Get GRAPHTRAX free!!!

## EPSON ACCESSORIES

GRAPHTRAX PLUS (bit-image/italics)	\$79
CABLE Model I interface & Model III	\$35
\$25 if purchased with EPSON printer	
CABLE & INTERFACE to Model I keyboard	\$85
APPLE interface & cable	\$89
GRAPPLER Apple hi resolution graphics	\$CALL
IEEE interface & cable (CBM/Pet)	\$79
ATARI cable (must have 850 interface)	\$35
SERIAL RS232 2k buffered int. card	\$149
RS COLOR computer to Epson card/cable	\$59

## EPSON PACK II

Screen oriented bit image graphics generator for Model III. Create your own characters, symbols, etc. Includes documentation. \$24.95 purchased with printer \$34.95 when purchased separately \$7.50 for update of Epson Pack I

Interfaces & cables available for most printers with any TRS80, Apple, Atari & most other computers. \$\$\$CALL FOR PRICES!

## ALTOS COMPUTERS

# TRS-80

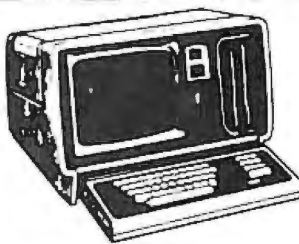

## \$CALL FOR PRICES

MODEL II 64K  
MODEL 16 1 DRIVE  
MODEL 16 2 DRIVE  
DT1 Data Terminal  
Mod 16 Memory Exp.

## COLOR COMPUTER

Original 90 day manufacturer's warranty

16k Level 1	\$308
16k Extended Basic	\$398
32k Extended Basic	\$CALL
Color Disk	\$479
Disk 1	\$349
Modem/full screen editor	\$39

TCS version Color Computers use original RS hardware and TCS memory. You get 180 day limited warranty on TCS Color Computer

16k Extended Basic	\$439
32k Extended Basic	\$499
32k Memory Upgrade	\$79
Color/Epson int. & cable	\$59
2k Buffer ColorGraph	\$155

## MODEL III SYSTEMS

Original 90 day manufacturer's warranty	
Model III 16k	\$818
Model III 32k	\$868
Model III 48k	\$918
Model III 48k 2Dr RS232	\$1944

TCS Model III Systems have quality TCS memory and 180 day limited warranty. No warranty when you open computer or add internal components after you receive it

TCS Model III 16k	\$799
TCS Model III 32k	\$818
TCS Model III 48k	\$848

## TANDON DRIVES

### DEALERS! ASSEMBLERS! Quantity Purchases Invited!

Bare drives are available, or you can buy them with power supply, cabinet and cable, fully assembled and ready to plug in to your computer.

#### INDIVIDUAL CABINETS

40 track single sided	\$249
80 track (dual sided 40 track)	\$389
160 track (dual sided 80 track)	\$499

#### BARE DRIVES ONLY

40 track single sided	\$199
80 track (dual sided 40 track)	\$299
160 track (dual sided 80 track)	\$399
5 inch Slimline sgi/dbi sided	\$CALL
Winchester hard drives 5-30 meg	\$CALL

#### DOUBLE CABINETS with 2 DRIVES

40 track single sided	\$489
80 track (dual sided 40 track)	\$699
160 track (dual sided 80 track)	\$949

Heavy gauge CABINET with POWER SUPPLY External gold connector allows instant hook/detach from drive cable

#### WE WILL NOT

BE UNDERSOLD!

## CORVUS HARD DISKS CALL FOR PRICES \$\$\$\$

Add 5, 10 or 20 megabytes of storage to your TRS80, Apple, Atari, Heath, Zenith, Intertec, IBM, S-100 and many others. One or several computers can share a hard disk. Get simultaneous access to data for multiple users. Available NOW at SUPER SAVINGS!

DEALERS... You can buy CORVUS from us for less. Call & SAVE.

## CUSTOM SOFTWARE FROM TCS

Completely integrated BINARY SEARCH TREE programs now available. This series of programs fully implements the B-TREE structures including INSERTION, DELETION, EDITING & TRAVERSAL. No more sorting or long data file searches and yet files can be larger than memory. Duplicate keys are fully supported. Files can be retrieved in sorted order via B-TREE Traversal. Each of the programs come with fully commented source code so that you can use the modules in your own programming. A Screen oriented input routine is also included in each module. The following B-TREE programs are now available and each includes all of the mentioned modules and full documentation

B-TREE Library (organize your home library keyed by author)	\$39.95
B-TREE Video (organize your video cassette library, prints labels, etc.)	\$39.95
B-TREE Mailing List (keyed by name or zip, label printing, etc.)	\$49.95



If you buy somewhere else, you'll probably pay too much!

For fast efficient service Heart of we can air freight from Dallas

## TEXAS COMPUTER SYSTEMS

P.O. Box 1327 Arlington, Texas 76004-1327

★ Toll Free Number 800 433-5184

Texas Residents 817 274-5625

• Prices subject to change at any time  
• No Tax out-of-state Texans add 5%  
• Many items shipped FREE Call for quote.

CALL FOR OUR

FREE CATALOG!

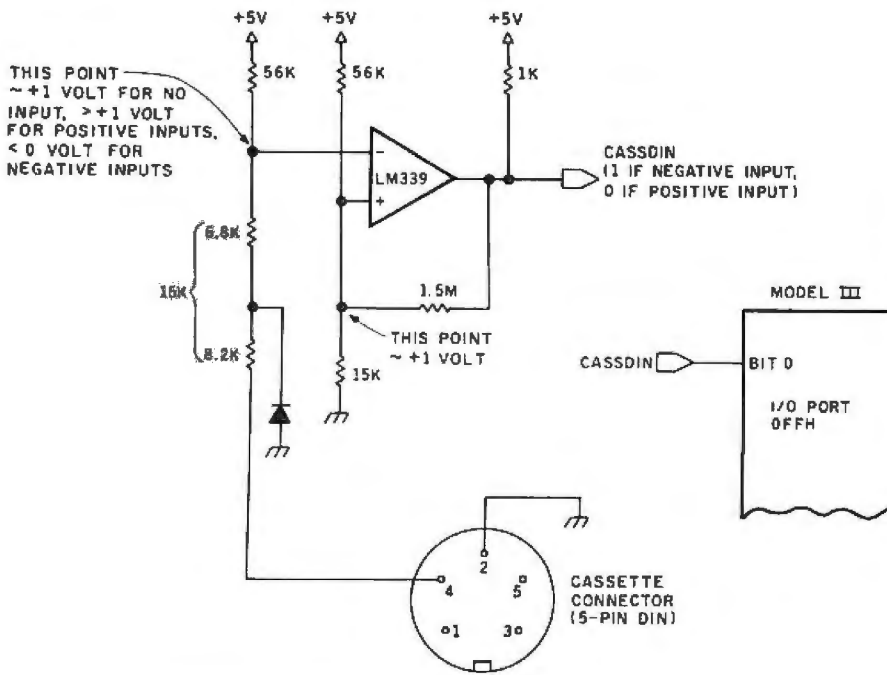

Figure 4: The Model III cassette input logic for 1500 bps uses a zero-crossing detector to detect when the input waveform goes negative. The output of the comparator goes to bit 0 of input port hexadecimal FF.

language allows you to sample the CASSDIN bit thousands of times per second. A BASIC INP(255) will also perform the same function but at much slower speeds.

It appears, then, that you can easily output square waves and read in a voltage level. How is this going to help you implement an analog-to-digital converter?

### New for '82!

Whilst paging through the ubiquitous Radio Shack catalog, I happened to see an ADC chip called the TL507C. At first glance it didn't appear very imposing (it's an 8-pin device and rather ugly, as semiconductors go), but it turned out to be a diamond in the Shack.

The internal workings of the TL507C are shown in figure 6. It uses a ramp method of A-to-D conversion and is made up of a 7-bit counter, a few gates, and two comparators.

The counter is the heart of the chip. It simply counts from 127 through 0 and repeats this cycle continuously. The counter may be reset at any time by bringing up the RESET input to a high ( $V_{CC}$ ) level. If the RESET is held at ground, the counter is powered up to some indeterminate state but settles into the 128-bit count cycle within 128 counts.

The 7 counter bits are connected to "binary-weighted" resistors. The resistors are actually a digital-to-analog converter (DAC) resistor "ladder" network. Each output of the counter produces a voltage that is twice as great as the preceding stage. The analog voltages are added together in the operational amplifier to produce the analog voltage corresponding to the value in the 7 bits of the counter. As the counter counts from 127 through 0, a ramp of voltage is generated, with each step of the ramp changing the output voltage by 1/128 of full scale. (See figure 7.)

The TL507C is designed so that one of two voltages may be used for power. The  $V_{CC1}$  input is the "normal" power supply input and may range from +5 to +6 VDC. The  $V_{CC2}$  input may be used instead; in that case, the power supply may be

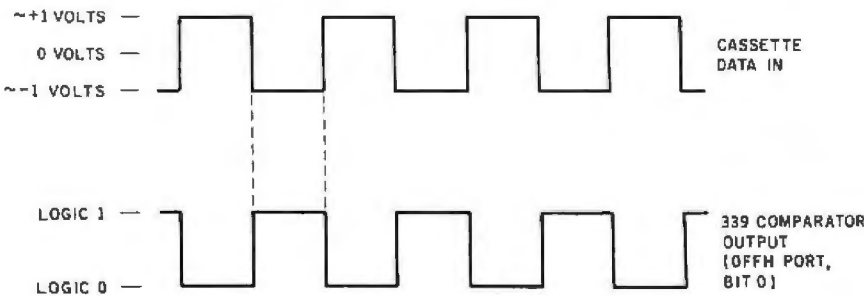

Figure 5: The cassette input waveform is a nominal 2 V peak to peak. The resulting output from the comparator is an inverted duplicate.

BASIC is much too slow to achieve the relatively short pulses required. A BASIC OUT (255) performs the same function at much slower speeds.

The Model III has two separate circuits for reading cassette data, one for 500 bps and one for 1500 bps. The 500-bps circuit works by essentially rectifying the incoming pulse and then looking for the DC level from the rectification. (It's very similar to the Model I circuitry.) The 1500-bps circuit uses a much different approach, as shown in figure 4.

The circuit in figure 4 is a zero-crossing detector that looks for negative pulses. The output of the LM339 comparator is a 0 with no input or a positive pulse, but it switches to a 1 with the negative-going edge of the pulse. It remains a 1 until the pulse switches back to a positive level, as shown in figure 5.

The CASSDIN (Cassette Data In) bit is read by performing the Z80 instruction IN (0FFH) and checking bit 0, the 1500-bps cassette bit (bit 7 is the 500-bps bit). Again, assembly

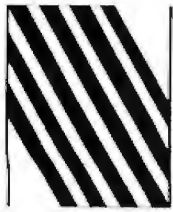

# NEECO



## Commodore Computer

VIC 20 Personal Computer	\$ 299 95
VIC 1515 Graphic Printer	\$ 395 00
CBM 4016	\$ 995 00
CBM 4032	\$1295 00
CBM 8032	\$1495 00
CBM SuperPet 9000	\$1995 00
CBM 8050 Dual Disk Drive	\$1795 00
CBM 4040 Dual Disk Drive	\$1295 00
CBM 2031 Single Disk Drive	\$ 695 00
CBM 4022 Tractor Printer	\$ 795 00
CBM 8010 IEEE Modem	\$ 279 00
CBM Datasette	\$ 74 95
CBM-IEEE Interface Cable	\$ 39 95
IEEE-IEEE Interface Cable	\$ 49 95



## Professional Software for CBM Computers

WordPro™ - a Family of CBM Word Processing Programs

WordPro 2 Plus	\$ 199 95
WordPro 3 Plus	\$ 295 00
WordPro 4 Plus	\$ 450 00
WordPro 5 Plus (for CBM 8096)	\$ 450 00
The Administrator (DataBase for CBM)	\$ 650 00
Power™ (Programmer's Utility ROM)	\$ 89 95
InfoPro™ (DataBase for CBM)	\$ 295 00

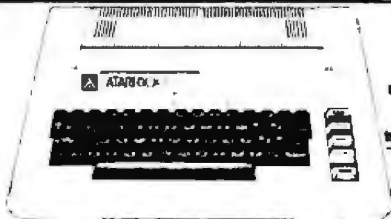

## Atari

Atari 400 16K	\$ 299 00
Atari 800 16K (incl. BASIC cartridge)	\$ 899 00
Atari 410 Recorder	\$ 99 95
Atari 810 Disk Drive	\$ 599 95
Atari 822 Thermal Printer	\$ 299 95

## Amdek Monitors

Video 100G (Limited Quantity)	\$ 119 00
Video 300G	\$ 185 00
Color 1	\$ 425 00
Color 2	\$ 899 00

## CMD Mupet

MC-800A Mupet Controller (Multi-User Controller for CBM Computers)	\$ 995 00
CM 100 Channel Module	\$ 250 00
Printer Module	\$ 350 00

## Qume

Sprint 9:45	\$2495 00
Tractor Option	\$ 210 00

## Epson Printers

MX-70	\$ 299 95
MX-80 w/Graphtrax	\$ 645 00
MX-80 FT	\$ 745 00
MX-100 FT	\$ 945 00
INTERFACE CARDS	
8141 RS-232 Interface Board	\$ 75 00
8145 RS-232 Interface Board w/2K Buffer	\$ 149 00
8151 RS-232 Interface Board w/X/ON-X/OFF	\$ 170 00
8161 IEEE Interface Board	\$ 55 00
8131 Apple Interface Card	\$ 85 00
8232 Apple Interface Cable	\$ 35 00
8220 TRS-80 Cable	\$ 35 00

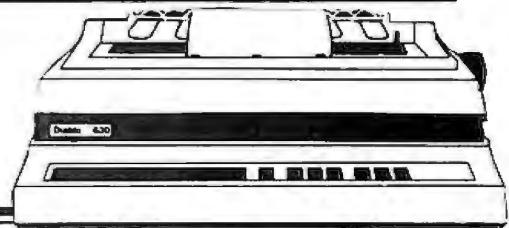

## Diablo 630 Printer

Diablo 630	\$2710 00
Tractor Option	\$ 350 00

## NEC Spinwriter Printer

NEC 7730	\$3085 00
NEC 7710	\$3085 00
NEC 7720	\$3610 00
NEC 3510	\$2290 00
NEC 3500RD	\$1895 00

Tractor Feed Options are available

\*WordPro, POWER, & InfoPro are registered trademarks of Professional Software Inc.

CALL FOR OUR 70 PAGE CATALOG FOR COMPLETE PRODUCT LINE AND PRICE LISTINGS

WE WILL MATCH SOME ADVERTISED PRICES ON CERTAIN PRODUCTS LISTED UNDER SIMILAR "IN STOCK" CONDITIONS



# NEECO

679 Highland Ave.  
Needham, MA 02194

## (617) 449-1760

TELEX: 951021

MON-FRI 9:00 - 5:30 E.S.T.



MASTERCARD \*VISA

**NOW INVESTMENT PROGRAMS THAT DO MORE COST LESS**

MarketTime High Yield

**FROM HOURGLASS** The mutual fund manager featuring portfolio review. Store transaction data including mutual and money market funds, IRA and Keogh plans. Get summary totals for dollars invested, withdrawn, plus rates of return.

**MARKET TIME™** With expandable data base that lets you add your own factors to the NYSE items provided with the program, then plot moving averages on screen or printer.

**\$75 each THE SOFTWARE REVOLUTION HAS BEGUN**

Available for leading computers including: Apple II\* and Z-80\* card, IBM-PC\*, Osborne\* and CPM\* systems.

\*These are registered trademarks of Apple Computer, Inc., Zilog, Inc.; IBM; Osborne Computers and Digital Research, Inc.

**HOURGLASS SYSTEMS™**  
 P.O. Box 312  
 Glen Ellyn, IL 60137  
 Place your order today:  
**(312) 690-1855**

COPYRIGHT 1982  
 HOURGLASS SYSTEMS

Dealer inquiries invited.

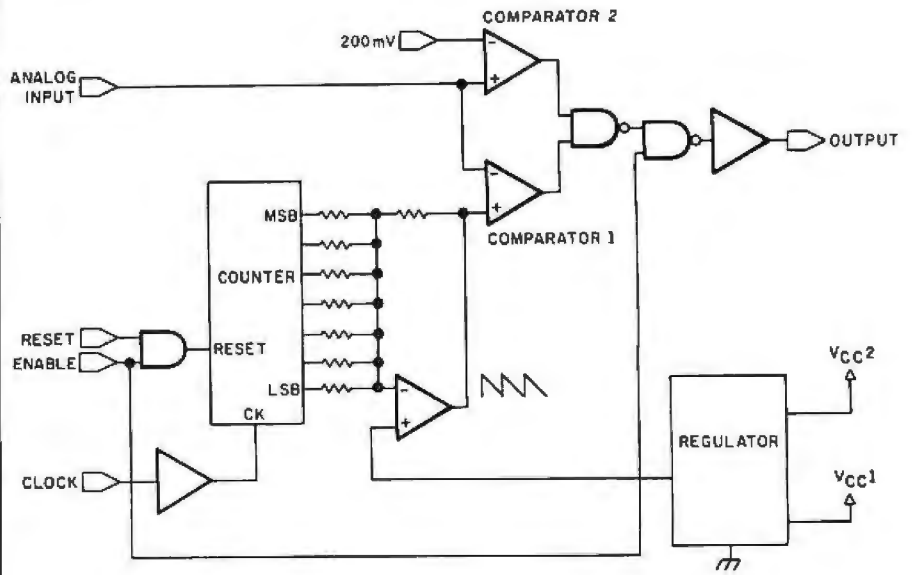

Figure 6: The TL507C chip is an analog-to-digital converter (ADC) that compares an analog input to an internally generated ramp voltage that steps through the allowable range of input voltages. The comparator output goes true when the ramp voltage falls beneath the analog input voltage.

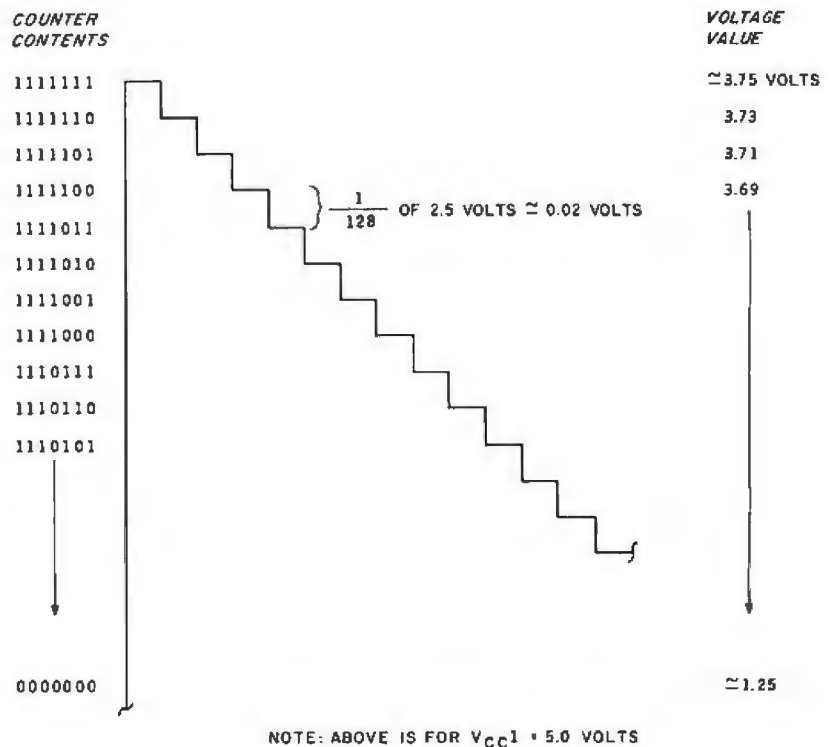

Figure 7: The TL507C generates a ramp of voltages from a 7-bit counter and a "weighted" resistor network. The smallest increment is 1/128 of the total voltage range for the ramp.



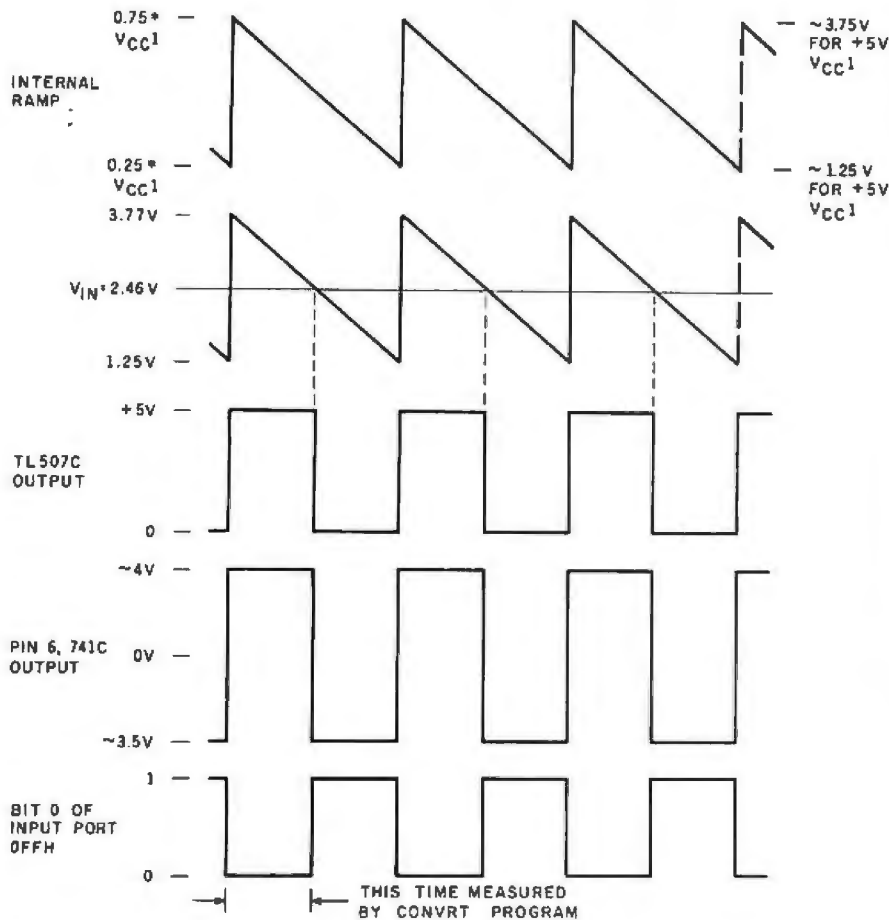

Figure 8: The analog-to-digital conversion is performed externally to the TL507C by measuring the duty cycle of the chip's waveform output. The duty cycle changes according to the analog input voltage.

"unregulated" and may range from 8 to 16 V. In the design that I've used here, I've chosen to use  $V_{CC1}$  and not  $V_{CC2}$ ; the  $V_{CC2}$  input is simply not connected.

The ramp voltage generated during a count cycle ranges from .75 of  $V_{CC1}$  through .25 of  $V_{CC1}$ . This range of voltages is accurately controlled by the TL507C. Therefore, with a  $V_{CC1}$  of +5 V, the ramp will range from +3.75 V through +1.25 V, as shown in figure 8.

The ramp output goes to comparator 1, which compares the analog input voltage and the ramp voltage. The output of the comparator is a 0 or 1 depending upon whether the analog input voltage is greater or less than the ramp voltage, respectively. For any constant analog input voltage, the comparator output will approximate a square wave as shown in the figure (labeled "TL507C Out-

put"). As the ramp repeats continuously (with a constant stream of clock pulses), the duty cycle (relationship of "on" time to total cycle time) will vary with the analog input voltage. With a large analog input voltage, the comparator output will quickly go to 0, while with a small analog input voltage, the comparator output will reach 0 near the end of the ramp.

The width of an "on" pulse is therefore directly proportional to the analog input voltage. If this pulse width can be measured, the analog input voltage can be determined easily. This approach would be used in a strictly hardware implementation of the TL507C circuit (e.g., measurement of the duty cycle of the output waveform).

An alternative approach is to increase the ramp voltage by outputting a single clock pulse, comparing the

NOW  
A SPREADSHEET  
THAT DOES MORE  
COSTS LESS



FAST FIGURE™  
FROM HOURGLASS

Save data entry time with the added dimension of file sharing. Fast Figure™ adds depth to data using full math, trig, business depreciation, NPV, IRR and growth functions. Features include cell level operation and control, prompting menus and flexible printing, all at a surprising price. Disk worksheets available for tax, business, investment and personal work.

\$150 THE  
SOFTWARE REVOLUTION  
HAS BEGUN

Available for leading computers including: Apple II\* and Z-80\* card, IBM-PC\*, Osborne\* and CP/M\* systems.

\*These are registered trademarks of Apple Computer, Inc.; Zilog, Inc.; IBM; Osborne Computers and Digital Research, Inc.

HOURGLASS  
SYSTEMS™  
P.O. Box 312  
Glen Ellyn, IL 60137  
Place your order today:  
(312) 690-1855

COPYRIGHT 1982.  
HOURGLASS SYSTEMS

Dealer inquiries invited.

# Let's Talk TEKnical

THE PIONEERING SPIRIT CONTINUES TO KEEP TEKTRONIX AT THE LEADING EDGE OF TECHNOLOGY...not only in oscilloscopes, but in microprocessor development systems, professional television equipment and computer graphics.

## CAE Applications Software Architect

Participate as the lead engineer of a team responsible for developing the applications architecture and demonstrating feasibility of future CAE applications S/W product concepts.

Here is an exciting opportunity to use your background and interest in CAE systems, S/W architecture, graphics H/W, data base, networking and S/W product development.

## Graphics Systems Software Architect

Participate as the lead engineer of a team responsible for developing graphics systems architecture and demonstrating feasibility of future product concepts.

Here is a challenging opportunity for you to use your background and interest in graphics systems, S/W architecture, computer architecture, graphics and networking.

Come share sailing on the beautiful Willamette, nearly year-round skiing and a host of other activities in the Pacific Northwest. There is housing to be found—and property, both reasonably priced. We have it here...the city life without the bustle, the culture without the crowd.

We offer excellent health and dental plans, a stock purchase plan and the most innovative profit sharing program in the industry. Join the team—send your resume to Iris Fuchs, MS Y6-010, P.O. Box 500, ACI1, Beaverton, OR 97077.

We are an equal opportunity employer m/f/h.

**Tektronix**  
COMMITTED TO EXCELLENCE

ANALOG INPUT CONDITION	ENABLE	OUTPUT
X	L†	H
$V_i < 200 \text{ mV}$	H	L
$V_{\text{ramp}} > V_i > 200 \text{ mV}$	H	H
$V_i > V_{\text{ramp}}$	H	L

† Low level on enable also inhibits the reset function.  
H = high level, L = low level, X = irrelevant

Table 1: My implementation of the ADC uses the last two function table entries. ENABLE is always H(igh), and the analog input voltage is not normally below  $.25 \times V_{cc}$ .

comparator output, pulsing the clock again, and so forth until the comparator output changes. If you know how many clock pulses you have output, you know the duty cycle. The total number of clock pulses in a ramp cycle is 128, and the duty cycle will be as follows:

$$\text{duty cycle} = \frac{\text{number of pulses before comparator switch}}{128 \times 10}$$

The scheme I'll use in my implementation of the ADC is to control the clock-pulse output and test the comparator output.

Getting back to the TL507C internal diagram, here are a few remaining points to consider. The ADC is set up so that an analog input of less than 200 mV disables the output. This level of voltage is considered to be an invalid input signal. Second, if the ENABLE input is grounded, the device OUTPUT signal will remain high (1). I'll keep the ENABLE input permanently active by tying it to  $V_{cc}$ .

The truth table for the TL507C is shown in table 1. Under normal circumstances, the only conditions you'll be working with would be the last two entries, for analog input voltages greater than 25% and less than 75% of  $V_{cc}$ .

## ELIZA IS HERE!

AT LAST! A FULL IMPLEMENTATION of the original ELIZA program is now available to run on your microcomputer!

Created at MIT in 1968, ELIZA has become the world's most celebrated artificial intelligence demonstration program. ELIZA is a non-directive psychotherapist who analyzes each statement as you type it in and then responds with her own comment or question — and her remarks are often startlingly appropriate!

Designed to run on a large mainframe, ELIZA has hitherto been unavailable to personal computer users except in greatly stripped down versions lacking the sophistication which made the original program so fascinating!

Now, our new microcomputer version possessing the FULL power and range of expression of the original is being offered at the introductory price of only \$25. And if you want to find out how she does it (or teach her to do more) we will include the complete Source Program for only \$20 additional!

Order your copy of ELIZA today and you'll never again wonder how to respond when you hear someone say "Okay, let's see what this computer of yours can actually do!"

### ELIZA IS AVAILABLE IN THE FOLLOWING DISK FORMATS:

- 1 Standard 8 inch single density for all CP/M based computers \$75 for ELIZA.COM + add \$20 for Microsoft BASIC-80 Source
- 2 5 1/4 inch CP/M for Apple II equipped with 2-80 SoftCard \$25 for ELIZA.COM + add \$20 for Microsoft BASIC-80 Source
- 3 5 1/4 inch for 48K Apple II with Applesoft ROM and DOS 3.3 \$25 for Protected File + add \$20 for Applesoft Source
- 4 5 1/4 inch for 64K IBM Personal Computer \$25 for Protected File + add \$20 for IBM Data BASIC Source
- 5 5 1/4 inch for Osborne I Microcomputer \$25 for Protected File + add \$20 for Microsoft BASIC-80 Source

### ARTIFICIAL INTELLIGENCE RESEARCH GROUP

821 NORTH LA JOLLA AVENUE  
LOS ANGELES, CALIFORNIA 90044  
(213) 656-7388 (213) 654-2214  
MC, VISA and CHECKS ACCEPTED



Circle 34 on Inquiry card.

## STATISTICAL SOFTWARE

ELF—Stepwise regression, factor analysis, correlation coefficients, cross-labs, simple statistics, t-tests, ANOVA, stepwise discriminant analysis, all BASIC transformations and more \$200.00.

TWG/ARIMA—Box-Jenkins for seasonal and non-seasonal models. \$300.00.

EAS/ARIMA—Automatic Box-Jenkins program for stock and commodity traders. \$300.00

All are for the Apple II\* with 48K of memory, Applesoft\* and DOS 3.3

Visa and MasterCard accepted.  
Call or write.

The Winckendon Group  
3907 Lakota Road  
P.O. Box 10114  
Alexandria, VA 22310  
(703) 960-2587

\*Trademarks of Apple Computer, Inc.

Circle 490 on inquiry card.

## PASCAL TOOLS

IBM PERSONAL COMPUTER

### WITH SOURCE CODE

- Common logical and arithmetic procedures including a pseudo random number generator
- All string routines which extend PASCAL and give the capability of advanced BASIC
- Screen handler and command line parser
- Reference documentation, User Manual and source code provided

Send check or money order for \$95.00  
(California residents add applicable sales tax)

**ECO** BLAISE COMPUTING INC.

1485 17th Avenue  
San Francisco, CA 94122 (415) 685-4711

Circle 58 on inquiry card.

## Electronic Circuit Analysis

- DC and AC analysis
- Very fast, machine language
- Infinite circuits on multiple passes
- Worst case, sensitivity analysis
- Dynamic modification
- 64 Nodes, 127 branches
- Compare circuits
- Log or linear sweep
- Full file handling
- Frequency response, magnitude and phase
- Complete manual with examples
- TRS-80 (TRSDOS) \$90.00
- CP/M \$150.00

Tatum Labs  
P.O. Box 722  
Hawleyville, CT  
06440  
(203) 426-2184

Circle 452 on Inquiry card.

## YORK 10 BASF-DPS WORLD STANDARD TAPE



MONEY BACK GUARANTEE

PREMIUM 5-SCREW SHELL FITS ALL STANDARD RECORDERS  
**COMPUTER GRADE BLANK CASSETTES**

"We monitored the output to the computer with a specially built meter and found absolutely no dropouts throughout the tape..."  
Stacy Papadopoulos  
Beaverton, OR

ITEM	1 DOZ.	2 DOZ.
C-05	7.50	13.50
C-10	8.00	14.00
C-20	10.00	18.00
Hard Box	2.50	4.00
Soft Box	2.00	3.40

Call residents add 6% sales tax  
Shipping 1 doz. \$2. 2 doz. \$3.50,  
3 doz. \$4.50. Each additional doz.  
\$.50  
Write or call for QUANTITY DISCOUNTS  
We accept VISA, MasterCard and Cash Card orders  
Call: 213/710-1430

**YORK 10 Computerware**  
24573 Kilridge St., B-4 Canoga Park, CA 91307

Circle 497 on inquiry card.

## HIGH QUALITY CONTROL DATA FLEXIBLE DISKS

5 1/4" Soft sector Price/10

1 side/ single density . . . . . \$23.00  
1 side/ double density . . . . . 26.80  
2 side/ double density . . . . . 33.40

8" Soft sector

1 side/ single density . . . . . \$25.00  
1 side/ double density . . . . . 30.00  
2 side/ double density . . . . . 36.80

Checks, M.O., VISA, M C  
Write Card Numbers, Expiration Date  
Add \$2.00 Handling Charge  
(408)252-4210

**Creativity Unlimited**

Dept. No. BY092 P.O. Box 3304  
Saratoga, California 95070-1304

Circle 136 on inquiry card.

## MICROANGELO Software



### GRAPH-PAK

Fortran compatible interactive plotting package based on CALCOMP standards  
Output is to MicroAngelo or to pen plotter . . . . . \$270.00  
(CP/M and Microsoft Fortran-80 required)

### SPRINT

Hardcopy program for MicroAngelo  
Output is to I D S. or EPSON graphics printers CP/M compatible . . . . \$125.00

Laboratory Computer Systems, Inc.  
139 Main Street, Cambridge, MA 02142  
(617) 547-4738

\* Trademark of SCION Corp

Circle 261 on Inquiry card.

## E-Z SCREEN EDITING with SCRED™ VERSION 1.0

SCRED is a new editor for CP/M systems with memory mapped video boards

- Immediate view of changes
- Assignable function keys
- Block move, copy, delete
- Re-definable CRT format
- Automatic BACKUP feature
- 8" SS SD CP/M compatible disk
- Width or length to 255 chrs

### PRICE

\$95 - SCRED, the definition routine and manual  
\$15 - manual only  
(refunded if software purchased)

Write **SOFTWARE PRODUCTS**  
7046 Park Mesa Way  
Suite 36  
San Diego, CA 92111

Or phone (714) 571-3217

Call res add 6% tax

Circle 431 on Inquiry card.



**Scotch**  
DISKETTES

SAVE 40% Write for our complete list.

5 1/4" Specify soft, Price/10  
10 or 16 sector

#744 1 side/sgl dens. . . . . \$26.70  
#744D 1 side/dbl dens. . . . . 31.20  
#745 2 sides/dbl dens. . . . . 38.40

8" Specify soft or 32 sector

#740 1 side/sgl dens. . . . . 27.30  
#741 1 side/dbl dens. . . . . 35.80  
#743 2 sides/dbl dens. . . . . 43.80

CHECKS - VISA - MC - C.O.D.  
(313) 777-7780 ADD \$2 SHIPPING

LYBEN COMPUTER SYSTEMS  
27204 Harper Ave.  
St. Clair Shores, MI 48081

Authorized Distributor  
Information Processing Products



Circle 272 on Inquiry card.

**SBC-880 S-100 IEEE STAND ALONE**

**SINGLE BOARD COMPUTER**

USES Z-80A (2 or 4MHz)

FEATURES: RS232 Parallel and Serial I/O Port • Programmable Band Rate 110-9600 • Programmable Interval Timers • On Board EPROM • 1K On Board RAM

Assembled and Tested, Regular \$325  
CABLE . . . \$25.00

**OUR PRICE \$295<sup>00</sup>**

---

**FDC-1 S-100 IEEE 696**

**FLOPPY DISC CONTROLLER**

USES WD1795-02

FEATURES: State of the art digital separator • 2 ZCPM Bus for SBC2-4 and FDC-1 • Drives both 5 1/4" or 8" unformatted • Step Rates can also be unformatted • SD and DD Formats • Digital Presenting Compensation, Assembled and Tested

Assembled and Tested, Regular \$350  
CABLE . . . \$35.00

**OUR PRICE \$325<sup>00</sup>**

---

**S-100 IEEE REAL TIME**

**CLOCK CALENDAR**

GIVE YOUR COMPUTER THE Hour-Minute-Second-Day Month-Year

FEATURES: Software control interrupts • On board Rechargeable Battery maintains clock when computer power is off

Assembled and Tested, Regular \$185

**OUR PRICE \$139<sup>00</sup>**

---

**THE SYNERGY-CARD FOR YOUR APPLE II**

FEATURES: Parallel Port • Serial Port • Clock Calendar • Two Interval Timers • BSR X-10 LINKS

Interface • 16K RAM  
Synergy-Card with 16K RAM and Instruction  
OPT-1 Adds Parallel, Serial and Timers \$69.00  
OPT-2 Adds Clock Calendar (must have Opt-1) 49.00  
OPT-3 Adds BSR X-10 Interface (must have Opt-1/2) 39.00  
Parallel Cable \$30.00 Serial Cable \$20.00

**\$195<sup>00</sup>**

---

**HIGH QUALITY S-100 MAIN FRAMES**

3 Models to Pick From

FEATURES: Forced Air Cooling • DB-25 Couters • +5VDC 25A and ±16VDC @ 5A Power Supply • Front Panel Power and Reset Switches • Slots and Power Supply for 5 1/4" or 8" Disc Drives

MF+ with 8 Slots \$450.00  
MF+MD w/8 Slots and Power Supply for 5 1/4" Drives \$550.00  
MF+DD w/8 Slots and Power Supply for 8" Drives 700.00

Please add extra shipping for this item \$12.00

---

**APPLE II COMPATIBLE ASCII FULL KEYBOARD COMPACT SIZE**

FEATURES: N-Key Rollover Function • Full ASCII Code Outputs • High Flexibility for Modification or Expansion • TTL Level Outputs • On-Off Indicators • Low Power Consumption

Apple II Keyboard

**OUR PRICE \$99<sup>00</sup>**

---

**TANDON DISC DRIVES**

TM100-1	5 1/4"	40 Track	SSDD	250K	\$248.00
TM100-2	5 1/4"	80 Track	DSDD	500K	319.00
TM100-3	5 1/4"	80 Track	SSDD	500K	320.00
TM100-4	5 1/4"	160 Track	DSDD	1000K	424.00
TMB48-1	8"	SLIMLINE	SSDD	500K	424.00
TMB48-2	8"	SLIMLINE	DSDD	1000K	569.00

---

**EPROM's**

2718	8 up	80 up	CALL	8118P-3(150-5)	1.50	1.20	CALL
2732	7.85	6.95	CALL	2114L-2(200-5)	2.10	1.70	CALL
2632	8.25	7.95	CALL	4164(200-5)	7.90	7.49	CALL

**RAM's**

17	8 up	80 up	CALL	17	8 up	80 up	CALL
----	------	-------	------	----	------	-------	------

**MISC**

CDP-1854ACE (UART) \$5.29  
Z-80A CPU 5.29

16K RAM EXPANSION KIT FOR TRS-80 MODEL III \$12.95/8

**FREE** WITH PURCHASE OF \$300 OR MORE

**SUNTRONICS CO., INC.**  
12621 CRENSHAW BOULEVARD  
HAWTHORNE, CALIFORNIA 90250

STORE HOURS: MON-FRI: 9:00am to 5:30pm  
SATURDAY: 10:00am to 5:00pm

IN CALIFORNIA: (213) 644-1149  
OUTSIDE CALIFORNIA TOLL FREE: 1-800-421-5775

Mail Order—Minimum Order: \$10. Send Money Order or Check to: P.O. BOX 1957—Dept. R, HAWTHORNE, CA 90250. Use your VISA or Mastercard (please include expiration date) Add \$7.00 postage and handling to order. California residents add 6% sales tax.

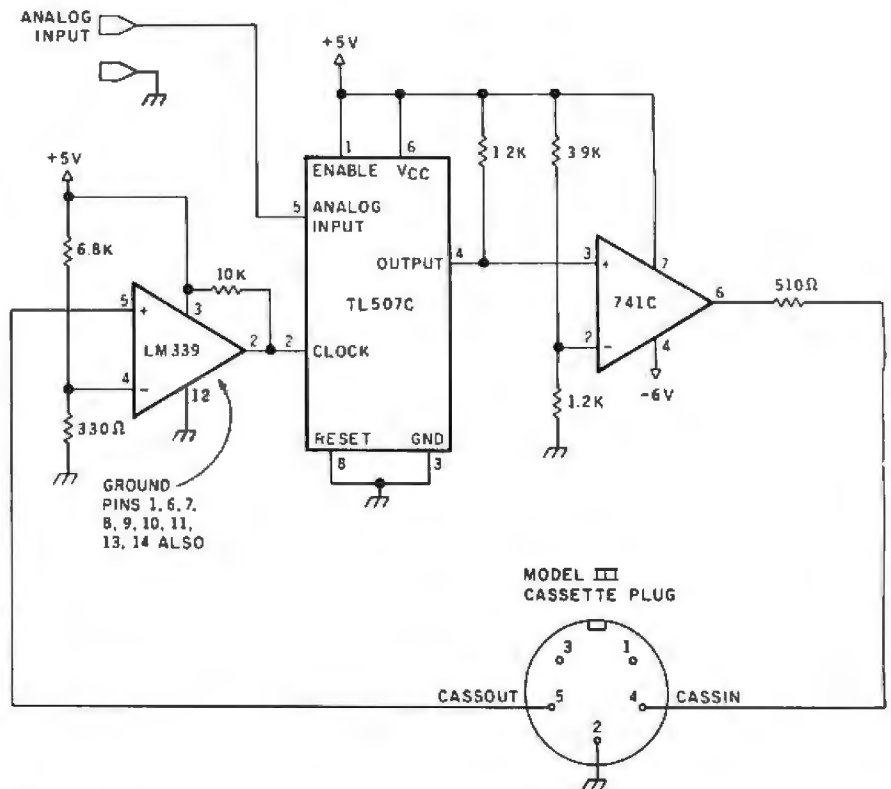

Figure 9: Three chips make up the ADC circuit that connects to the cassette jack of the Model III. The TL507C is the heart of the ADC, and the remaining chips perform level conversion.

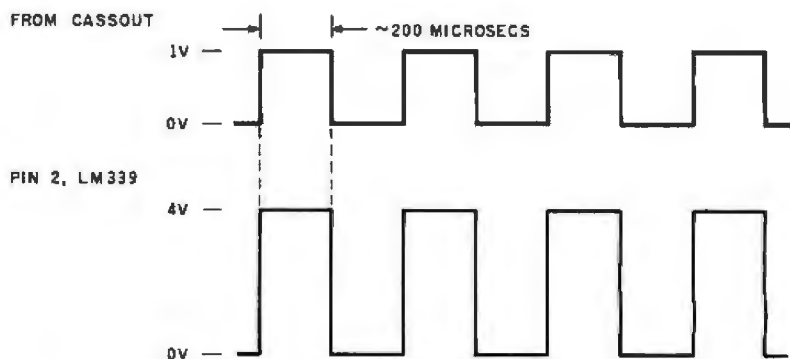

Figure 10: The LM339 comparator changes the 1-V peak-to-peak cassette output waveform to a TL507C-compatible level.

**The A-to-D Circuit**

The circuit for the Model III ADC is shown in figure 9. The heart of it, of course, is the TL507C. The LM339 comparator is used for level conversion of the Model III cassette output signal, while the 741C is used for level conversion to a Model III-compatible cassette input signal.

The CASSOUT signal. The clock

input to the TL507C is derived from the Model III cassette output. This clock input would normally be the signal that goes to the AUX input of the cassette recorder during a write/tape operation. The CASS-OUT signal is shown in figure 10. It is a 0- to 1-V square wave.

The clock input to the TL507C must be at least 2.5 V, which calls for

# Prepare Even the Most Complicated Programs Quickly, Easily!

## With **EZ.COM** Software Programming Aid

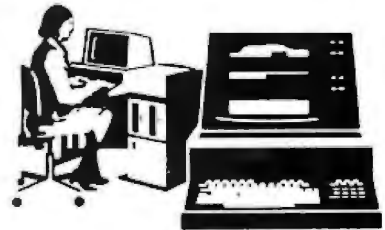

Program logically, conveniently by structure and modularity!

EZ.COM is an efficient programming tool that drastically reduces total cycle time of programming and eliminates the tedious construction of complex programs. EZ.COM creates and maintains libraries of program modules.

- Modules may be as long as 100 lines. Each library may be as large as 8 megabytes and may contain as many as 16 thousand modules.
- Modules may be created, transferred from another library or from other program source listings.
- Modules have no format restrictions and may consist of coding, tables, description text, display formats, etc!
- Modules are filed random access allowing instant storage and retrieval.

*Written in efficient and fast 8080 assembly, EZ.COM produces easily debugged and understandable programs faster than any other technique. Many programs may coexist in the library in the form of module lists which may then be used to obtain source files. Using lists arranged as hierarchical structures, the most modern techniques of structured and modularized programming may be used. A library index is available on demand along with module catalogs and program source listings.*

### **EZ.COM OFFERS THE SIMPLEST TO LEARN, EASIEST TO USE FULL PAGE EDITOR YOU'LL EVER SEE!**

- All the special options and features you'll ever want!
- All edit features are detailed on an edit help page—a key stroke gets it and a second returns you to your original place.
- A spooler is provided for listing while you are editing.
- Useful for novices or experts.
- Easy to use, easy to learn & fast.

**GOOF PROOF?** You can bet on it! An OOPS Key is provided to back out of any situation. Syntax edit is performed on the way in; all commands will be grammatically correct. RESET at any time, the files are protected.

For \$195 we'll send you the program along with sample files and reports on an IBM format 8" single density floppy, and an instruction manual you'll find to be an invaluable programming aid. Or, send \$35 for the manual alone (later applied towards your purchase of the program.) \$5.00 will bring you a program description with sample modules and reports.

**The Softwarehouse**  
1542 W. Pepper  
Mesa, Arizona 85201  
or Call (602) 969-1430

\*Requires CPM, 48 K RAM, at least one disk, and the dumbest of terminals.

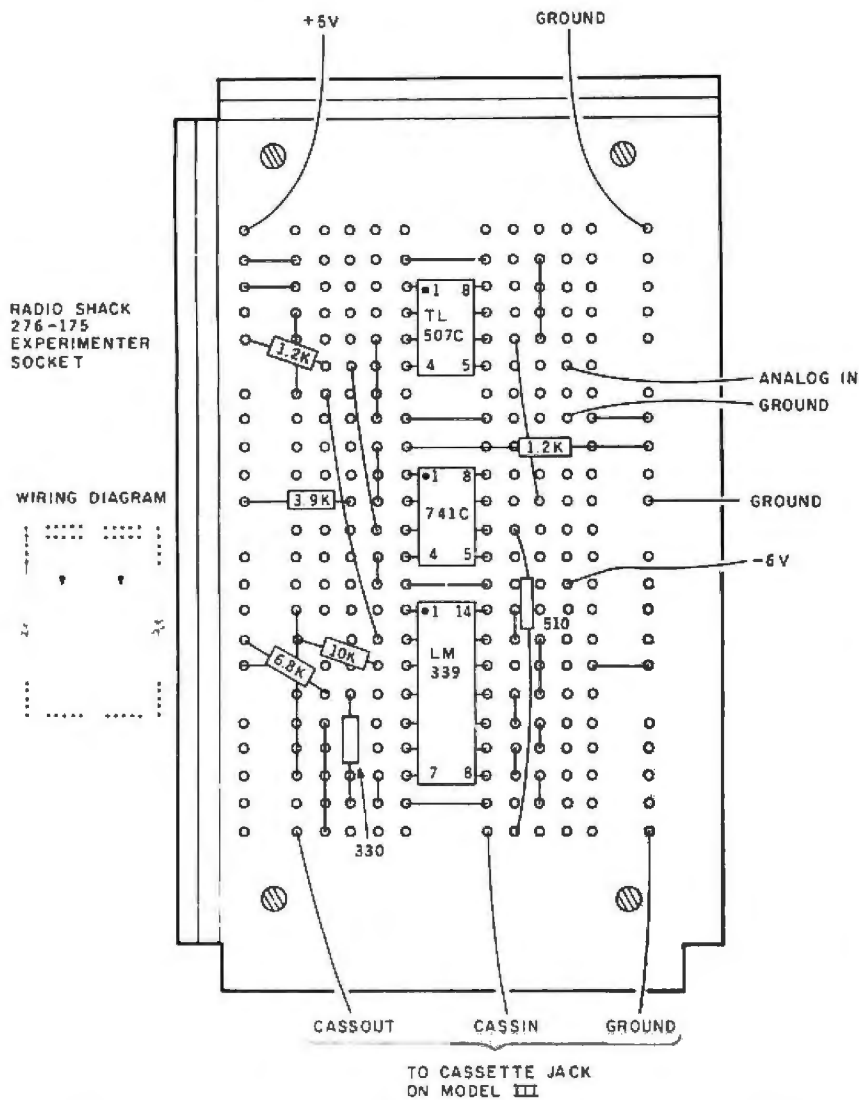

Figure 11: The simple and inexpensive ADC is constructed on a Radio Shack 276-175 prototype board.

some level conversion of the CASSOUT signal. The LM339 accomplishes this by comparing the CASSOUT signal to a voltage of about .25 V at the junction of the 6.8k-ohm and 330-ohm resistors. The output of the LM339 is shown in the figure; it is identical to the CASSOUT signal except that it has a greater voltage swing.

The CASSOUT signal is the clock for the TL507C. Each pulse will be (arbitrarily) set to a width of about 200  $\mu$ s. The counter in the TL507C changes on the negative-going portion of the clock pulse. A complete ramp will require 128 clock periods.

**The CASSIN signal.** The cassette input circuitry in the Model III responds to a negative voltage level. The output voltage of the "open-collector" output line from the TL507C swings from about 0 V to about +5 V and must therefore be converted to a waveform that swings both positively and negatively. The 741C accomplishes this by comparing the output voltage with 1.2 V at the junction of the 3.9k-ohm and 1.2k-ohm resistors. The output of the 741C follows the output of the TL507C as shown in figure 8.

**Other connections.** The ENABLE input of the TL507C is tied to +5 V,

making the chip always active.  $V_{CC2}$  is not connected. RESET is tied to ground. The counter will be at some meaningless value when power is first applied but thereafter will repeat modulus 128. The ANALOG INPUT is tied to ground.

### Constructing the ADC

The ADC circuit was built up on a Radio Shack 276-175 prototype board shown in figure 11. The prototype board has two bus columns for power and ground on the left and right sides of the board. There are two sets of 23 rows used for connecting integrated circuits (ICs).

The figure is meant as a general guide for interconnections; use the logic diagram of figure 9 as the definitive circuit. Solid lines in the construction figure represent solid bus wires; these can be routed under or over components. Note the keying of the IC chips. Pin 1 on all chips is at the upper left corner.

After the board has been wired up, recheck the wiring and prepare the power cables. The two wires on top go to a +5 V power supply. Radio Shack has an inexpensive +5 V kit (277-125) that you can use for this purpose.

The -6 V wires on the right side should be connected to the -6 V supply for the 741C. You may substitute a +6 V battery in place of a large power supply with no problem as the 741C will draw negligible amounts of current. The positive lead to the battery or power supply attaches to the ground bus of the prototype board.

The three leads on the bottom go to the cassette-input jack on the Model III. The proper pin numbering is shown in figure 9 and has been discussed in a previous article (see "A Po(r)tpourri of Ideas" in the April 1982 BYTE issue, page 158). For testing purposes, simply clip test leads to the existing Model III cassette cable as shown in figure 12.

The two leads for the analog-input signal connect to the voltage to be measured. A simple voltage divider, which uses one 10k-ohm potentiometer and a 10k-ohm resistor, is shown in figure 13.

# A HARD DISK COMPUTER AT A PRICE THAT'S HARD TO BEAT.



**\$5,995**

## RTI INTRODUCES "THE COMPETITOR"

- **Micro-computer:** Produced by **ADDS** Applied Digital Data Systems Inc., a subsidiary of NCR
- **CPU:** 5MHz 8085A-2
- **RAM:** 64K Bytes, parity protected
- **DISK:** 5 Megabyte formatted 5¼" HARD DISK
- **Mini-Floppy:** 800K Bytes formatted
- **INPUT/OUTPUT PORTS:**
  - Serial port—console terminal (bidirectional)
  - Serial port—communications up to 9600 baud
- 8 bit parallel port—Centronics type printer
- 13 bit parallel port—Letter Quality printer
- **Service available through the NCR Corporation nationwide and worldwide network**
- **Standard Software:**
  - MUON (CP/M Compatible multi-tasking operating system)
  - BASIC interpreter (Micro Soft)
- **Dimensions:** 15½" W x 15½" D x 8¾" H
- **Weight:** 35 lbs.

Everything listed above... only \$5,995!  
"The Competitor" is an integrated system, well-supported, with hard-disk and floppy backup that will run CP/M software in a large variety of business applications.

We call it "The Competitor" because it is priced lower than many kits and hobby-grade products, yet offers more features, more reliability, more support.

With it, you can start small—but not too small. You can run accounting (which usually requires hard disk), inventory, A/R, A/P word processing, mailing lists, billing, budgeting, and more. Plus, you can expand by adding multi-user capabilities (up to 4 terminals), more disk capacity (10 megabytes), additional RAM memory (in 64KB increments), and a second printer.

For your minimum system, you will need a CRT terminal and a printer, which are priced extra.



**Terminal: ADDS Viewpoint—\$639.**

- Movable keyboard
- Micro-technology
- Screen-tilt & Glare-reducing filter
- 6 Built-in international character sets

**Printer: Centronics Model 739—\$649.**

- 10 cpi, 16.7 cpi and elongated print at a speed of 100 cps in the mino space mode and 80 cps in proportional space mode

MUON Viewpoint are Trademarks of ADDS. CP/M, CB80, PASCAL, MT+ are trademarks of Digital Research. CBASIC is a trademark of Compaq System Inc. Wordstar, Mailmerge, Supersort, Spellstar, Datastar, Calcstar are trademarks of Micro Pro International. Accounting Plus is a trademark of Software Dimension Inc.

### SOFTWARE:

We've tested many CP/M packages and can assure you that they load, run and do everything expected.

Because space is limited, we can only list a few of the most popular packages available from RTI.

### CP/M SOFTWARE:

#### Languages—

- |                                     |        |                                  |        |
|-------------------------------------|--------|----------------------------------|--------|
| <input type="checkbox"/> CBASIC     | \$135. | <input type="checkbox"/> FORTRAN | CALL   |
| <input type="checkbox"/> PASCAL/MT+ | \$315. | <input type="checkbox"/> PL/1    | \$450. |
| <input type="checkbox"/> COBOL      | \$765. | <input type="checkbox"/> CB80    | \$450. |

#### Word Processing—

- |                                    |        |                                    |        |
|------------------------------------|--------|------------------------------------|--------|
| <input type="checkbox"/> Wordstar  | \$445. | <input type="checkbox"/> Supersort | \$225. |
| <input type="checkbox"/> Mailmerge | \$135. | <input type="checkbox"/> Spellstar | \$225. |

#### Accounting Plus—price/module \$629.

- |   |  |  |
|---|--|--|
| <input type="checkbox"/> General Ledger | <input type="checkbox"/> Inventory     | <input type="checkbox"/> Sales Order     |
| <input type="checkbox"/> Payables       | <input type="checkbox"/> Payroll       | Entry                                    |
| <input type="checkbox"/> Receivables    | <input type="checkbox"/> Point of Sale | <input type="checkbox"/> Purchase Orders |

#### Data Base Mgmt.—

- |                                   |        |                                   |        |
|-----------------------------------|--------|-----------------------------------|--------|
| <input type="checkbox"/> Datastar | \$315. | <input type="checkbox"/> Calcstar | \$265. |
|-----------------------------------|--------|-----------------------------------|--------|

### Yes. Please send me...

- |   |          |
|---|----------|
| <input type="checkbox"/> "The Competitor" | \$5,995. |
| <input type="checkbox"/> The Terminal     | 639.     |
| <input type="checkbox"/> The Printer      | 649.     |

Total enclosed \$ \_\_\_\_\_

Please add state sales tax, where applicable. Shipping charges will be billed to you.

Please check the components and software you want. Make check payable to Research Technology International. Prices are F.O.B. factory. Send your order to:



4700 Chase  
Lincolnwood, IL 60646

Name \_\_\_\_\_

Company \_\_\_\_\_

Address \_\_\_\_\_

City, State, Zip \_\_\_\_\_

Phone (\_\_\_\_\_) \_\_\_\_\_

In a hurry? Call RTI, toll-free, 800/323-7520. In Illinois, Alaska, Hawaii, or outside the USA, phone 312/677-3000.

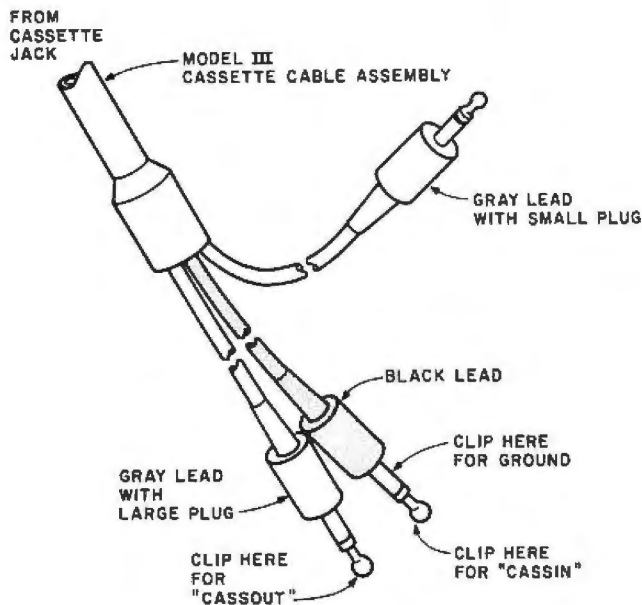

Figure 12: The existing cassette cable for the Model III may be used to connect the ADC to the computer system. Three clip leads connect all signals.

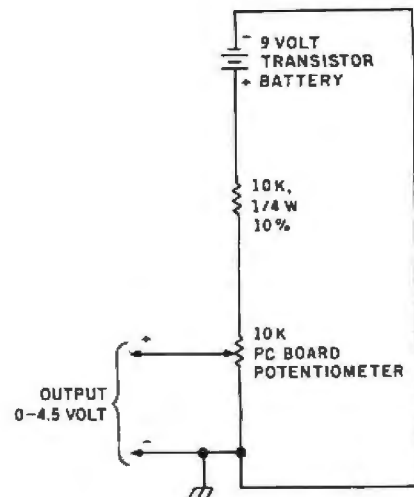

Figure 13: The ADC may be tested by a simple voltage divider made from a 9-V transistor battery, a 10k-ohm resistor, and a 10k-ohm printed-circuit-board potentiometer.

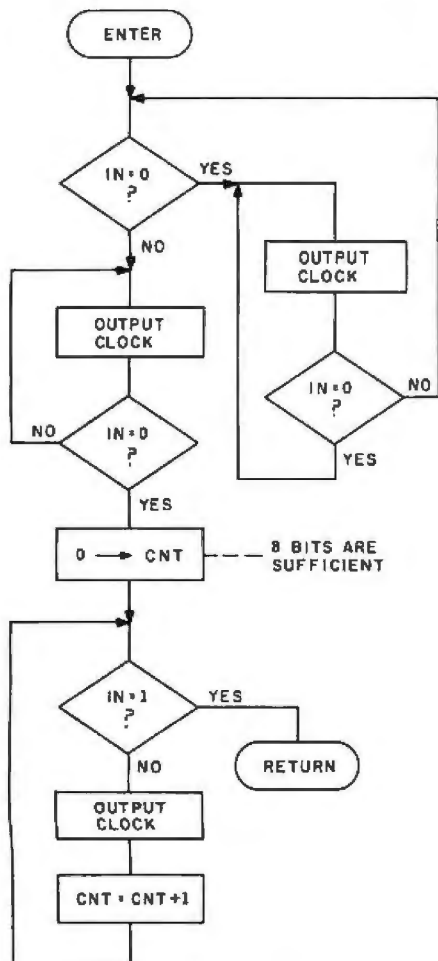

Figure 14: The ADC algorithm is straightforward. Starting from a known condition, the cassette input is sampled and the clock pulses are counted until the analog input voltage falls below the ramp voltage.

### The Software

The flowchart in figure 14 shows the basic scheme for measuring the duty cycle by counting clock pulses. The CASSIN signal is read from bit 0 of I/O port hexadecimal FF. This bit is a 1 when the analog input voltage is higher than the ramp voltage.

If the input is a 0 initially, the ramp voltage is higher than the analog input voltage. In this case, clock pulses are output (via CASSOUT) until the input bit goes to a 1 (i.e., the ramp voltage is lower than the analog input voltage).

If the input is a 1, clock pulses are output until the ramp voltage rises above the analog input. At this point a count is set to 0. The maximum count will be 128, which can be held in one byte.

Now, clock pulses are output until CASSIN goes to 1. The count is incremented for each clock-pulse output. When CASSIN goes to 1, the ramp voltage has fallen below the analog input voltage.

This algorithm is implemented in the assembly-language program shown in listing 1. Three subroutines are used: TSTIN, OUTCLK, and DELAY.

DELAY simply causes a pause for a fixed amount of time, about 200  $\mu$ s. It's called by OUTCLK to create a

fixed-width clock pulse of 200  $\mu$ s.

OUTCLK outputs one complete clock cycle to CASSOUT. The cassette toggle is first set one way by outputting a 2 to port hexadecimal FF. DELAY is then called. Next, the cassette toggle is set to the opposing voltage level by an output of 1. DELAY is called again.

The TSTIN subroutine is called by the main CONVRT program to test the state of the CASSIN line. The state of CASSIN is returned in the Z flag; Z is set (Z) if CASSIN is 0 or reset (NZ) if CASSIN is 1.

TSTIN also tests a "time-out" count in the DE register pair. The count is incremented; after 65,536 times, it will recycle to 0. When that occurs, TSTIN resets the stack and returns control to the calling (BASIC) program. Time-out occurs when CASSIN does not change state within a reasonable amount of time, and it is indicated by returning a count of -1.

The main driver portion of CONVRT implements the logic shown in the flowchart by calling TSTIN and OUTCLK. At the end of CONVRT, the count of clock pulses is held in the HL register pair and returned to BASIC by the standard return of "JP 0A9AH," which returns the HL register contents to a BASIC variable.

The assembly-language version of





**The Computer Book Club**  
has the latest titles  
on hardware, software,  
theory, and applications,  
**PLUS** ready-to-run  
tapes and disks at the  
lowest prices anywhere!

Select 6 fact-filled books  
for only **\$2.95** (total value up to \$111.70)



338 List \$14.95      1076 List \$12.95      1307 List \$16.95

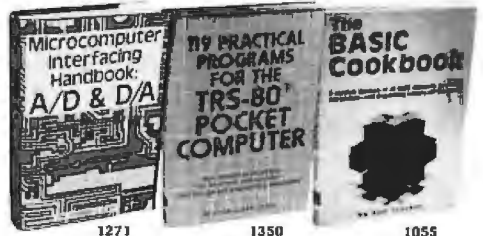

1271 List \$16.95      1350 List \$15.95      1055 List \$9.95



1466 List \$17.95      335 List \$14.95      1241 List \$12.95      1414 List \$15.95      1295 List \$16.95      1160 List \$13.95      1200 List \$11.95      1183 List \$14.95



1111 List \$15.95      1195 List \$12.95      1053 List \$13.95      334 List \$16.95      1406 List \$17.95      1301 List \$17.95      336 List \$14.95      1050 List \$10.95



1314 List \$15.95      1088 List \$13.95      337 List \$19.95      1380 List \$18.95      1330 List \$15.95      1398 List \$13.95      1062 List \$12.95      1473 List \$16.95

**Join The Computer Book Club! Get 6 Best Selling Books for only \$2.95 (VALUES TO \$111.70)**  
**Seven reasons why you belong in The Computer Book Club**

- You save money.** Save up to 75% on books and ideas sure to increase your know-how. You'll save even more because you'll be able to perform many tasks without calling in outside help.
- Your satisfaction guaranteed.** Any book you buy is returnable within 10 days without obligation.
- You receive news of new books and ideas.** About 13 times a year, you will get a Club News Bulletin with current book selections and bonus offers—dozens of up-to-the-minute titles you can pick from, each with exciting new ideas.
- You receive books automatically.** You will receive automatically a new book selected by the Computer Editorial Board as a Main Selection. But, you can choose another book or no book at all by mailing the business reply form contained in each News Bulletin.
- You get special bonuses.** The club has special sales and added-value promotions for members to increase your library of knowledge. And, after fulfilling your membership obligation, you will receive a dividend certificate with each book purchased to qualify for even greater discounts.
- You'll have a library of exceptional quality.** Each Computer volume is a full-length publisher's edition, filled with useful, up-to-the-minute information.
- You'll gain practical knowledge and confidence.** The Computer Book Club will add to your practical skills about jobs that you face every day. All books contain easy-to-understand language that will add to your confidence in completing almost any task.

**The Computer Book Club**  
Blue Ridge Summit, PA 17214

Please accept my membership in The Computer Book Club and send the 6 volumes circled below. I understand the cost of the books selected is \$2.95 (plus shipping/handling). If not satisfied, I may return the books within ten days without obligation and have my membership cancelled. I agree to purchase 4 or more books at reduced Club prices during the next 12 months, and may resign any time thereafter.

334 335 336 337 338 1050 1053  
1055 1062 1076 1088 1111 1160 1183 1195  
1209 1241 1271 1295 1330 1350 1380  
1391 1394 1396 1397 1406 1414 1466 1473

Name \_\_\_\_\_ Phone \_\_\_\_\_  
Address \_\_\_\_\_  
City \_\_\_\_\_  
State \_\_\_\_\_ Zip \_\_\_\_\_

(Valid for new members only. Foreign and Canada add 20%. Orders outside U.S. or Canada must be prepaid with international money orders in U.S. dollars).  
This order subject to acceptance by The Computer Book Club BY-982

Listing 1: The A-to-D conversion program for the Model III, which implements the algorithm for measuring the duty cycle by counting clock pulses.

```

7F00      00100      ORG      7F00H      ;CHANGE THIS AS REQD
          00110      ;*****
          00120      ;* A TO D CONVERSION PROGRAM FOR MODEL III      *
          00130      ;* INPUT: NONE      *
          00140      ;* OUTPUT:(HL)=CONVERSION COUNT OR -1 IF TIME OUT *
          00150      ;*****
7F00 110000 00160 CONVRT LD      DE,0      ;TIME OUT COUNT
7F03 CD2B7F 00170 CON005 CALL   TSTIN      ;LOOK FOR 1
7F06 200A    00180      JR      NZ,CON020 ;GO IF 1
7F08 CD3B7F 00190 CON010 CALL   OUTCLK     ;0; WAIT 'TIL 1
7F0B CD2B7F 00200      CALL   TSTIN      ;TEST
7F0E 28F8    00210      JR      Z,CON010  ;GO IF STILL 0
7F10 18F1    00220      JR      CON005    ;RESTART
7F12 CD3B7F 00230 CON020 CALL   OUTCLK     ;NOW LOOK FOR 0
7F15 CD2B7F 00240      CALL   TSTIN      ;TEST
7F18 20F8    00250      JR      NZ,CON020 ;GO IF STILL 1
7F1A 210000 00260      LD      HL,0      ;INITIALIZE CONVERT CNT
7F1D CD2B7F 00270 CON030 CALL   TSTIN      ;NOW LOOP 'TIL 1
7F20 2006    00280      JR      NZ,CON090 ;GO IF 1
7F22 CD3B7F 00290      CALL   OUTCLK     ;PULSE
7F25 23      00300      INC     HL      ;BUMP COUNT
7F26 18F5    00310      JR      CON030    ;TRY AGAIN
7F28 C39A0A 00320 CON090 JP      0A9AH     ;RETURN WITH ARG
7F2B 13      00330 TSTIN  INC     DE      ;BUMP TIME OUT CNT
7F2C 7A      00340      LD      A,D      ;TEST FOR DE=0
7F2D B3      00350      OR      E      ;
7F2E 2006    00360      JR      NZ,TST010 ;GO IF NO TIME OUT
7F30 21FFFF 00370      LD      HL,-1     ;SET ERROR FLAG
7F33 D1      00380      POP     DE      ;RESET STACK
7F34 18F2    00390      JR      CON090    ;RETURN
7F36 DBFF    00400 TST010 IN      A,(0FFH) ;READ CASS IN
7F38 E601    00410      AND     1      ;GET 1500 BAUD BIT
7F3A C9      00420      RET      ;RETURN
7F3B 3E02    00430 OUTCLK LD      A,2      ;ONE WAY
7F3D D3FF    00440      OUT     (0FFH),A ;OUTPUT
7F3F CD4A7F 00450      CALL   DELAY     ;DELAY ABOUT 200 MICS
7F42 3E01    00460      LD      A,1      ;OPPOSITE WAY
7F44 D3FF    00470      OUT     (0FFH),A ;OUTPUT
7F46 CD4A7F 00480      CALL   DELAY     ;DELAY 200 MICS
7F49 C9      00490      RET      ;RETURN
7F4A 0619    00500 DELAY  LD      B,25     ;ABOUT 200 MICS
7F4C 10FE    00510 DEL010 DJNZ   DEL010
7F4E C9      00520      RET      ;RETURN
0000      00530      END
000000 Total errors

```

CONVRT executes at location hexadecimal 7F00. Listing 2 shows a BASIC driver program that calls CONVRT and also incorporates the machine-language code of CONVRT as a series of DATA statement values. The code is moved to the hexadecimal 7F00 area before execution of the BASIC program.

The BASIC driver for CONVRT converts the count returned from CONVRT to a voltage level, predi-

cated upon a +5 V supply for  $V_{cc}$ . The iteration count is displayed in the middle of the screen along with the voltage value.

When  $V_{cc}$  is exactly +5 V, the allowable analog input can be +1.25 V through +3.75 V, for a total range of 2.5 V. Because there are 128 steps, each step represents 2.5/128 V, or about 0.01953 V. The actual voltage read from the analog input is expressed as:

$$V = (+3.75) - (CNT - 1) \cdot 0.01953$$

and this value is calculated and displayed on the screen.

### Using the ADC

Connect all power leads to the ADC and turn on the +5 V and -6 V DC. Make the obvious "smoke tests"; none of the chips should feel hot to the touch.

Connect a voltage source to the

# 16 Bit 8086 Multi-User Microcomputer System

FOR **MP/M-86™**

**\$7595**  
**FOUR**  
**USER**  
**SYSTEM**

**ONLY**  
**\$1899\***  
**PER**  
**USER**

THE  
**TEC 86M**



**1/2 MEGABYTE**  
**OF MEMORY**  
**TWO 8 INCH D.D.**  
**FLOPPY DISKS**

## STANDARD FEATURES

- 16 BIT 8086 CPU** - Processor performance is the most critical element in a Multi-User System. Speed, power and the increased throughput of our 16 Bit 8086 CPU are just a few of the reasons why our TEC 86M Multi-User Systems really perform.
- 1/2 MEGABYTE OF MEMORY** - The second most important factor which affects system performance is available user memory. Our 1/2 Megabyte, four user system gives each user well over 100K Bytes of memory, eliminating program size compromises which lead to poor Multi-User system performance.
- MP/M-86™ COMPATIBILITY** - The TEC 86M includes a ROM Boot for MP/M-86™ and is designed to provide optimal support for MP/M-86™. The MP/M-86™ Operating System is available separately from Tecmar for \$600. See Software Options listed below for important MP/M-86™ features.
- FULLY INTERRUPT DRIVEN** - The TEC 86M provides terminal and disk I/O interrupts to MP/M-86™, allowing for maximum system performance in Multi-User operation.
- TWO 8 INCH DOUBLE DENSITY FLOPPY DISK DRIVES** - The two Double Density floppy disks total 1.2 Megabytes of storage. Options include double sided floppy disk drives and Winchester drives.
- FOUR SERIAL USER PORTS** - Four serial user ports are provided. Each port can be independently set for speeds from 50 to 19200 Baud.
- MULTIPLE PARALLEL PORTS** - Parallel ports are provided for operating printers as well as other parallel devices.
- EASILY EXPANDABLE** - The modular design of the Tec 86 and Tec 86M assures you of continued system expandability. All options are easily field installable. Available options include: Memory 64K and 256K, additional users, double sided floppy disks, Winchester 31 Megabyte hard disk, terminals, and printers.
- ATTRACTIVE DESKTOP ENCLOSURE** - Tecmar Single and Multi-User systems come in your choice of an attractive desk top enclosure with wood grained side panels to blend nicely into your office surroundings, or an industrial quality cabinet for more hostile environments. Rack mount enclosures are available as options.
- ONE YEAR WARRANTY** - Tecmar Systems are fully assembled and thoroughly tested. All Tecmar Components carry a full One Year Warranty.

## SOFTWARE OPTIONS

- MP/M-86™** - Multi-User interrupt driven Operating System for the 16 Bit 8086 TEC 86M Microcomputer System.
  - FILE PASSWORD PROTECTION** - Access to user files can be restricted to require proper passwords prior to access.
  - CONCURRENT FILE ACCESS** - Files may be accessed by multiple users, each reading and/or writing the same file, with protection provided at both the file and the record level.
  - FILE TIME AND DATE STAMPING** - Files contain creation, and modification Times and Dates for ease and accuracy in determining the latest or most useful file versions.
  - PRINT SPOOLER** - Files may be submitted to the System Spool file for printing. This frees the user terminal to continue operation during the independent printing function.
  - LANGUAGES** - BASIC-86™ FORTRAN-86™ PASCAL-86™ CBASIC/86™ CIS-COBOL™ PASCAL/M86™ FORTH
- \*NOT INCLUDING MP/M-86 and User Terminals.

## OTHER FINE S100 and APPLE PRODUCTS AVAILABLE, INCLUDING:

- ANALOG to DIGITAL CONVERTERS** (12, 14, 16 bit accuracy; 30, 40, 100, 125 KHz Conversion rates; 16 to 256 Channels; programmable gain; timer/counters).
- DIGITAL to ANALOG CONVERTERS** (12 bit accuracy, 3 microsecond conversion rate). 8086 CPU Board, I/O Boards 64K/256K Memory Boards, Real-time Video Digitizer and Display. Complete Systems also available for Data Acquisition, Video Digitization, and General Purpose Applications.

REQUEST OUR CATALOG FOR COMPLETE LISTING, AND SPECIFICATIONS ON THE ENTIRE TECMAR PRODUCT LINE.

**TECMAR**  
INC. →

DEALER INQUIRIES INVITED

23600 Mercantile Rd. • Cleveland, OH 44122

**TECMAR, INC.**  
(216) 464-7410

CP/M-86 and MP/M-86 are registered trademarks of Digital Research Inc. BASIC-86, FORTRAN-86 and PASCAL-86 are registered trademarks of Microsoft Inc. PASCAL/M86 is a registered trademark of SYBEX. CBASIC/86 is a registered trademark of Computer Systems Inc. CIS-COBOL is a registered trademark of Microsoft Inc.  
CANADA: Our Ontario Distributor is OCTANT COMPUTER SERVICES INC., 146 Front Street West, Suite 485, Toronto, Ontario M5J 2L7 (416) 598-1046

**Listing 2:** A BASIC driver program that calls the program CONVRT and incorporates the machine-language code of CONVRT as a series of DATA statement values.

```

100 ' MODEL III TL507C A TO D CONVERSION DRIVER
110 DATA 17,0,0,205,43,127,32,10,205,59,127,205,43,127,40,248
120 DATA 24,241,205,59,127,205,43,127,32,248,33,0,0,205,43,127
130 DATA 32,6,205,59,127,35,24,245,195,154,10,19,122,179,32,6
140 DATA 33,255,255,209,24,242,219,255,230,1,201,62,2,211,255
150 DATA 205,74,127,62,1,211,255,205,74,127,201,6,25,16,254,201
160 FOR I=32512 TO 32590
170 READ A: POKE I,A
180 NEXT I
190 DEFUSR0=&H7F00
200 CLS: I=0
210 A=USR0(0)
220 IF A=-1 THEN PRINT @ 512+20,"OUT OF RANGE"           ":GOTO 210
230 I=I+1
240 A=(.75*5)-(A-1)*(2.5/128)
250 PRINT @ 512+20,I,INT(A*100)/100;"
260 GOTO 210

```

analog input, which can be the circuit shown in figure 13 or simply a 1.5 V battery connected between ground and the input lead.

Connect the cassette leads either by clip leads or specially wired cable to the cassette DIN jack at the rear of the Model III.

Protect the hexadecimal 7F00 RAM (random-access read/write memory) area and enter the BASIC program. Double-check the DATA statements for correct values. Execute the BASIC program. You should see a slight pause as the machine-language code is moved from the DATA statements to the hexadecimal 7F00 area. The screen should clear, and you should then see the iteration count followed by the voltage value on the screen.

If you do not see a conversion voltage immediately, recheck the power and wiring connections. If the

analog input is not properly connected, you should see the "OUT OF RANGE" message.

The ADC components and timing are not critical, and if you experience trouble, chances are it's in the wiring or machine-language code. You may troubleshoot the circuit by outputting pulses by the following BASIC code:

```

100 OUT 255,1
110 OUT 255,2
120 PRINT @ 512+20,INP(255)
    AND 1
130 GOTO 100

```

This code outputs clock pulses at a very low data rate but one still sufficient to cycle the ADC through the ramp voltages in a few seconds. The input should alternate between 0 and 1, depending upon the analog input voltage.

### How Does It Work?

Damn fine! All kidding aside, this is one of those projects that works extremely well, thanks to the specifications of the TL507C chip. The values in table 2 show the output obtained from various analog inputs. Inputs above +3.75 V and below +1.25 V are considered out of range, but all other inputs are measured very accurately.

The number of samples (conversions) per second is about 6. Actually, each sample should take anywhere from about 2 clock pulses (1 millisecond [ms]) to a worst case of about 256 clock pulses (128 ms), corresponding to a range of 1000 to 7.8 samples per second. However, the sluggish BASIC interpreter reduces the number of samples per second to about 6, regardless of the analog input voltage. This conversion rate could

The **HOME BRAIN™** is a dedicated microcomputer system in a stand-alone package. **HOME BRAIN'S™** I/O potential exceeds 300 channels.

## ACHIEVE TOTAL HOME CONTROL

- Energy Management
- Home Security
- Lighting Control
- Safety Monitoring
- Appliance Control

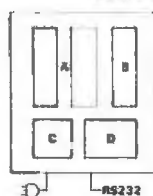

- A - 32 Channels Buffered Input
- B - 8 Relay Output
- C - Uninterruptable Power Supply
- D - CPU, Communications, 256 Channel AC Wireless Control

## THE HOME BRAIN™ IS

### the First Total Home Control Computer

- Communicate with the **HOME BRAIN™** using your personal computer RS232 interface
- **HOME BRAIN™** controls your home using your define logic sequences
- Logic diagrams, timers, counters, alarm clocks, calendars, are directly implemented by the **HOME BRAIN™** microprocessor
- **HOME BRAIN™** logs controlled operating times for the month

The **HOME BRAIN™** operates totally independent of your personal computer. Crashing your computer will not crash **HOME BRAIN™** leaving your home defenseless.

## EVALUATE THE HOME BRAIN™

Order Now By Calling Toll-Free

**1-800-228-2028**

**EXT. 332**

Lines Open 8 AM To 6 PM G.S.T.



Just give us your Name, Shipping, Address and Visa or MasterCard number and we will charge the \$850.00 purchase price, plus \$20.00 shipping (N.J. residents add 5% sales tax) to your account. Or, **SEND\*** your **CHECK\*** or **MONEY ORDER\*** to

**HYPERTEK, INC**  
**30-4 FARM ROAD**  
**SOMERVILLE, NEW JERSEY 08876**

\*Sending your check will qualify you for an **INTRODUCTORY REBATE** of 10%

Allow 6-8 weeks for delivery

# SUPER-WAND

A FULL COLOR GRAPHIC LIGHTPEN SYSTEM FOR THE APPLE

## THE FACTS:

1. The Best Low Resolution Lightpen on the Market
2. Complete Demo Program Standard
3. Store to Disk; Recall from Disk. Any Picture Any Time
4. Hard Copy Printout Using ASCII Characters to Represent Colors
5. Keyboard Color Editor Standard — Erase or Change Any Color Any Time
6. Easy to Understand User Prompts
7. Extensive Professionally Written User's Guide and Quick Reference Card for All Keypress Commands
8. 30-Day Warranty
9. You get Lightpen, Disk and User's Guide
10. Will work on either Black and White or Color Monitors/TV Sets

## THE NEEDS:

1. Apple II or Apple II+
2. Firmware Applesoft and 20K or Language Card (48K)
3. Interger Version Available (20K)
4. 1 Disk Drive
5. (Optional) 80 Column ASCII Printer

THE COST  
**\$88.00**  
COMPLETE!

# INSTASORT

THE MOST VERSATILE, POWERFUL SORT PROGRAM FOR MICRO'S — PRICED UNDER \$100<sup>00</sup>

## I. CAPABILITIES

- A. Create user defined file formats consisting of records up to 128 characters long. Will allow up to 1000 records per file.
- B. Allows user to select up to 7 keys from fields within the record, thereby automatically sorting the file in 7 different ways.
- C. Single item search on any key
- D. Partial listing of file according to any key in either ascending or descending order.
- E. Complete list of file according to any key in either ascending or descending order. This means the capability to do 14 different listings of the same file — 28 different listings if you include the partial listing capabilities.
- F. Allows correction of records, addition and deletion of records
- G. Allows limited arithmetic manipulation (Addition & Subtraction) of selected numeric fields.
- H. Allows user to merge separate but identically formatted files to form a single file of up to 1000 records.
- I. Allows complete listing of file in the original order.
- J. Multiple nested key searches
- K. Complete Professional written User Guide included.

## II. HARDWARE LIMITATIONS

- A. Requires minimum of 48K main memory
- B. Requires 2 disk drives (500 records max [single density], 1,000 records max [double density])
- C. CP/M Operating System

## III. SOFTWARE LIMITATIONS

- A. Maximum of 1000 records per file.
- B. Limited Arithmetic operations.
- C. No more than 7 keys all of which must be complete fields (no possibility of splitting keys into smaller fields for use as a key)

THE COST  
**\$95.00**  
COMPLETE!

	PRICE	QUANTITY	AMOUNT
SUPER-WAND	\$88.00		
INSTASORT	\$95.00		
Shipping and Handling			\$4.95
<b>TOTAL</b>			

## ORDER TODAY!

### MAIL TO:

Data-Rite Industries, Inc.  
P. O. Box 976, Spokane, WA 99210  
Include Check or Money Order  
Payable to Data-Rite Industries, Inc

### OR CALL:

Data-Rite Industries, Inc.  
Inside Wash. (509) 455-9147  
Outside Wash. 1-800-541-9001  
Visa or Master Card  
accepted on Phone Orders

NAME \_\_\_\_\_

ADDRESS \_\_\_\_\_

CITY/STATE/ZIP \_\_\_\_\_

# North Star has the Advantage over IBM and Apple.

Before you buy a desktop computer, compare these important North Star features with both the IBM PC and the Apple III. Priced from \$3599, the North Star Advantage gives you more than twice the disk storage per dollar of either the IBM PC or the Apple III.

**Only North Star offers both 8 bit and 16 bit power.**

With our new Advantage 8/16, you can run industry standard 8 bit CP/M<sup>™</sup> software plus new 16 bit software (including software available for the IBM PC).

**Better business graphics.**

The North Star Advantage comes complete with graph preparation software, and its screen precision beats both IBM and Apple.

**Low-cost expandability and service.**

The North Star Advantage provides cost-effective expandability to meet your growing needs: from 8 bit to 16 bit power, from single user to multi-user networks and from floppy disk to higher capacity Winchester storage. And only North Star offers you a choice of carry-in or on-site service. For the name of the North Star dealer nearest you, call toll-free

## 1-800-447-4700

(Illinois 1-800-322-4400).



FOLLOW THE STAR

### NorthStar<sup>™</sup>

14440 Catalina Street,  
San Leandro, California 94577

CP/M is a registered trademark of Digital Research Inc.

Digital Voltmeter	Screen Value
< 1.26	OUT OF RANGE
1.30	1.30/1
1.40	1.42
1.50	1.50/2
1.60	1.58/9
1.70	1.69/70
1.80	1.79/80
1.90	1.89/91
2.00	1.99/2.01
2.10	2.09/1.11
2.20	2.18/9
2.30	2.28/9
2.40	2.40
2.50	2.48/9
2.60	2.59
2.70	2.67/9
2.80	2.79
2.90	2.89/90
3.00	2.98/9
3.10	3.08/9
3.20	3.18
3.30	3.28/9
3.40	3.37/8
3.50	3.47/9
3.60	3.57/9
3.70	3.69
3.74	3.73/5
3.76	3.75
> 3.76	OUT OF RANGE

Table 2: Test results show an excellent linearity for analog input voltages from  $.25 \times V_{cc}$  through  $.75 \times V_{cc}$ .

be "cranked up" by increasing the clock-frequency output on CASSOUT.

The accuracy of the conversion is unaffected by such system functions as real-time-clock interrupts because the program counts directly each clock pulse.

### ADC Applications

In my project presented in the January BYTE article, I used transducers to convert light and temperature to voltage levels, which were then read by an ADC and input to the computer as digital information. There are many different types of transducers that convert other physical quantities into voltage levels. This simple and inexpensive ADC can be used to monitor the outputs of such devices and send them to the Model III for recording and processing. In the next two articles of this series, I'll look at simple and inexpensive transducers and show you how to use ADCs for the Model I, Model III, and Color Computer. ■

# Not Even These Guys Can Promise Complete Protection

## Does your insurance?

It's a startling fact, but most homeowners insurance doesn't cover home computers with business uses. That means your valuable investment could be unprotected even while you read this. Exposed to the risks of fire, theft, even accidental damage.

## SAFEWARE™ does

Introducing SAFEWARE. The new insurance designed to protect your valuable investment when others won't. Re-

gardless of use, SAFEWARE provides for full replacement coverage after a low \$50 deductible. That includes all your hardware, media, even purchased software.

## For just pennies a day

You can insure the average system for just pennies a day. Find the value of your system in the table below and see just how low the price for SAFEWARE protection really is. If you need higher limits, call us toll free for a low-cost quote.

## Columbia National General Agency

New SAFEWARE insurance is underwritten by the American Druggists' Insurance Company, and is offered exclusively by Columbia National General Agency. Both companies are members of the Armco Insurance Group, one of the nation's leading property and casualty insurers.

## For immediate coverage

No matter what the application, you can get immediate coverage for your system with the coupon below. Mail to: Columbia National General Agency, 88 East Broad Street, Columbus, Ohio 43215. 614/224-7235. Or call the toll free number for coverage today! 800/848-0598.

# CNGA

COLUMBIA NATIONAL  
GENERAL AGENCY



Amount of Insurance	Annual Premium
Up to \$2,000	\$ 35
\$ 2,001-\$ 5,000	\$ 60
\$ 5,001-\$ 8,000	\$ 75
\$ 8,001-\$11,000	\$ 90
\$11,001-\$14,000	\$105
\$14,001-\$17,000	\$125

Not avail. in AL, AK, AZ, AR, DE, DC, GA, HI, IL, KY, LA, ME, MS, MT, NV, SC, SD, or WY

Name \_\_\_\_\_  
 Street \_\_\_\_\_  
 City \_\_\_\_\_  
 State \_\_\_\_\_ Zip \_\_\_\_\_  
 System value \$ \_\_\_\_\_  
 Check enclosed     VISA     MasterCard  
 Card # \_\_\_\_\_ Exp \_\_\_\_\_  
 Send additional information

BY

# The Case of the Purloined Object Code: Can It Be Solved?

## Part 1: The Problems

*A specialist in software and high-technology law explains why new laws are necessary.*

---

Richard H. Stern  
Stern & Roberts  
2555 M St. N.W.  
Washington, DC 20037

---

Three recent decisions of federal tribunals on whether object code in read-only memories (ROMs) is protectable under the U.S. copyright laws show that copyright protection against competitive unloading and duplication of ROMs is insecure. The three decisions suggest that unless and until a more satisfactory software protection law is enacted, software proprietors' exclusive rights to ROMs and other important forms of software will remain doubtful. Devising a proper software law is not a simple matter, however, for conflicting interests pull in different directions and accommodation of these interests is difficult.

This two-part article reviews the problems in using copyright law to

protect object code and other software, focusing on the unloaded-ROM problem and using the three ROM cases to illustrate the difficulties faced. The article then comments briefly on the unsatisfactory and inappropriate protection that present patent, contract, and trade-secret laws provide for software, particularly object code. Next month, I will discuss some of the questions that would have to be answered before a well-considered law on protecting ROMs, object code, or other software could be written. The conclusion is that we can solve the case of the purloined object code, but only after answering some difficult questions about software policy.

### The ROM Cases

The three unloaded-ROM decisions go very different ways, partly because of their facts, but at least as much because of the extraordinary difficulty of the legal issues. In one case, the court held that unloading and duplicating a ROM was not a copyright infringement. In another, the court held the opposite. The third tribunal refused to decide the question because it was too difficult.

**The Compuchess Case:** The first U.S. decision on whether the federal copyright laws protect object code or ROMs involved the Compuchess hand-held calculator game. When Data Cash marketed Compuchess in 1977, it unwisely believed that it was technologically infeasible to unload a ROM. Accordingly, Data Cash took no special legal or technical steps to protect the object code in the ROMs of its games. This turned out to be a serious mistake. A competitor brought a lower-priced knockoff game on the market, containing a ROM unloaded from the Compuchess ROM. This set the stage for the first lawsuit over purloined object code. (*Data Cash Systems, Inc. v. JS&A Group Inc.*, 480 F. Supp. 1063 [N.D. Ill. 1979], aff'd on other grounds, 628 F. 2d 1038 [7th Cir. 1980].)

The software proprietor lost when the trial court held that object code was not a "copy" of the copyrighted source code, as far as the definition of "copy" under the copyright laws was concerned. A copy of source code would have to be source code, not object code, and definitely not a mechanically utilitarian device such

---

### About the Author

*Richard H. Stern is a lawyer specializing in intellectual property and antitrust law. As Chief of the Justice Department's Intellectual Property Section, he tried and supervised the government's patent and antitrust litigation, including the computer software patent cases in the Supreme Court. He is now in private practice in Washington, DC, dealing with the problems of high technology and computer software. Mr. Stern also has a degree in electrical engineering.*

---



# NO WAITING



## Now, with Microfazer you can compute while you print.

Time is money. You own a computer system because you know that it can save you money by simplifying office procedures and reducing the time involved in payrolls, accounting, word processing and those other wonderful things we all must do. Time is an important resource which should not be wasted. Even though your system seems efficient, you could be wasting valuable time if you ever wait for your printer to finish printing before more information can be entered into your computer.

**NO WAITING.** Now with Microfazer by Quadram there will be no more waiting.

The Microfazer is an inexpensive universal printer/buffer that can be used with all popular micro-computers and parallel printers. Microfazer receives information from the

computer at up to 4000 characters per second (your computer thinks the printer is printing this fast), holds it until your printer can handle it, and then sends it on to the printer. Controlled by a custom LSI, Microfazer uses standard centronics signals and is powered by the printer or an inexpensive external AC adapter. Buffering of 8K, 16K, 32K or 64K is available.

**EASY INSTALLATION.** The Microfazer is in a small case (3.5" x 7" x 1"). It is engineered to be plugged directly into the input port of the Epson and other similar printers. Installation can be completed in less than 60 seconds. How's that for not wasting time! Most other centronics compatible printers can be attached by using an adapter cable.

**FLEXIBLE.** If you should purchase a faster printer later, just unplug and add to your new printer. Changing Computers? Microfazer is not computer dependent. Want to add more buffer? No problem. Microfazer is

user-expandable up to 64K. No other buffers came close in flexibility.

**LOW PRICE.** Only \$159 for 8K buffer, \$199 (16K), \$225 (32K) and \$299 for full 64K. Serial-to-Parallel and Serial-to-Serial versions are available at slightly higher prices.

**QUADRAM QUALITY.** The Microfazer was designed with performance and reliability in mind. With a one year warranty, you get Quadram Quality at a surprisingly low price.

**ASK YOUR DEALER.** If you are currently wasting time waiting on your printer, see your local personal computer dealer. If your dealer is not currently stocking Quadram products, have them call us at (404) 923-6666.

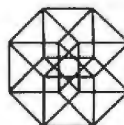

**QUADRAM**  
CORPORATION

4357 Park Drive/Norcross, Ga. 30093

## The Protection of Video-Game Displays

*This article does not attempt to explore in depth a different aspect of copyright law relating to computer programs—the protection of video-game displays, apart from the programs used to generate them. I will briefly touch on the point in this text box, but the issues are too complex (and too peripheral to those discussed in this article) to do them justice. Accordingly, in a subsequent article, I will describe how the courts have recently begun to protect the audiovisual images associated with particular subroutines in computer code used to generate output displays in the video monitors of video-game machines.*

*A pervasive issue is how close one game's "characters" and "plot" can come to that of another game before there is an infringement, assuming that the second game is not just an unloaded-ROM copy of the first. In one puzzling decision, which probably goes further than any other, the court protected Pac-Man against K. C. Munchkin, an enhanced version of Pac-Man. In another case, however, the court refused to protect Asteroids*

*against the enhanced version Meteors. Other pending cases involve the issue of "speed-up" kits—whether the seller of a video-game machine can stop a customer from putting enhancement ROMs into the machine.*

*A few tribunals have been persuaded that the video game itself constitutes some kind of audiovisual work of authorship, or that the fixed subroutines within it do. See e.g., Atari, Inc. v. North Amer. Phillips Consumer Elec. Corp., 672 F.2d 607 (7th Cir. 1982); Stern Electronics, Inc. v. Kaufman, 523 F. Supp. 635 (E.D.N.Y. 1981), *aff'd*, 669 F.2d 852 (2d Cir. 1982). The International Trade Commission seems initially to have rejected the argument, but later to have accepted it. In this view, the copyright registration based on filing a video tape of a play mode performance containing audiovisual image subroutines 1 through n confers protection against performance of any permutation of any number of the n audiovisual image subroutines.*

*I find this theory difficult to believe, but video-game manufacturers have in*

*some way persuaded several courts to believe it. Accordingly, there must be something to the argument.*

*It should be noted that the argument, good or bad, would appear inapplicable to data processing and other ordinary computer applications. Video games contain continuous audiovisual real-time output displays made up of permutations of the image subroutine displays, such as the explosion image display sequence of the Galaxian game, with each part or image subroutine (or else their aggregate) claimed to be an audiovisual "work." But the output of a data-processing program would seem to be only a printout of tabulated data or the like. It would seem difficult to find anything in the data-processing output that corresponds to subroutines in the program and that could be characterized as a "work." The only work of authorship in sight, in a data-processing context, is the program itself, not the output. Perhaps some pie-chart graphics or the like could be considered a work of visual or graphic arts.*

as a ROM. In so ruling, the court relied on prior cases holding that such physical objects as buildings and dresses were not infringing copies of the blueprints or patterns for those buildings or dresses. In addition, the court expressed its opinion that object code, when physically embodied, is not directly or indirectly protectable under the copyright laws. Therefore, unloading object code from a ROM (or, presumably, from a tape or disk) is not infringement of a copyright on any form of the program.

The second point raises a fundamental problem with use of copyright to protect ROMs, disks, and tapes. The copyright laws were enacted under the Copyright Clause of the U.S. Constitution, which authorizes Congress to pass laws protecting the rights of "authors" to their "writings." A program written in a high-level language is generally recognized as a literary work and the writing of an author. It meets the

general test of being a means of communicating ideas or emotions from one person (the author) to another (the reader, viewer, listener, etc.). Perhaps assembly code is in the same category. But a program in object code is generally unintelligible to human beings (the vast majority of whom are unable to read object code). Probably more important, object code is not intended for a reader, viewer, or listener. Rather, it is intended to be a utilitarian object—to operate a processor in response to data inputs with which it coacts to produce outputs. The outputs may be intelligible and communicate ideas or emotions, but the outputs are not the object code—they are something else, a third thing.

The problem with object code, as the court in the Compuchess case saw it, is that it is not a medium of human-to-human communication. As the court said, "The 'source program' is a writing while the 'object

program' is a mechanical tool or machine part." The ultimate rationale for the second point made in the Compuchess case is that the copyright laws are intended to protect media of human communication and not functional, utilitarian objects. It is unclear, however, whether the court was talking only about ROMs themselves or also about printouts or "dumps" of ROMs. The logic appears to apply to both.

**The Galaxian Case:** The second purloined-object-code case involved coin-operated video games. A major U.S. distributor of arcade game machines, Midway, secured exclusive U.S. rights to the Galaxian video game from its Japanese originator. The game machine contains a microprocessor that combines player signal inputs (lever and button signals) with program information from a ROM (or several ROMs) to drive the video display.

# WILD HARE AND DATA GENERAL IN TRIUMPHANT FINISH!



## GREAT NEWS FOR DATA GENERAL USERS!

Win in the race for productivity by teaming up with Wild Hare. Our TSS software enhancer makes your system as productive as a rabbit.

Wild Hare's operating system enhancement gives Data General NOVA<sup>®</sup> and ECLIPSE<sup>®</sup> users the most from their system. TSS allows you to transform RDOS, ICOS (CS/COBOL) and INFOS<sup>®</sup> into true multi-lingual, multi-user Time Sharing Systems.

This state-of-the-art system accommodates up to 26 users. Each user can independently edit, compile and execute programs using the

language of his choice, like FORTRAN, ALGOL, BASIC, COBOL, Pascal, Assembler and more.

TSS combines RDOS, INFOS<sup>®</sup> and ICOS compatibilities with AOS capabilities at a mere fraction of the cost.

In the race for productivity, Wild Hare gives you the edge by multiplying the capabilities of your Data General system. So start things hopping with a 30-day trial run. Remember, slow and steady could eventually win the race. But it takes a Wild Hare in the program for a truly productive finish.



wild hare  
COMPUTER SYSTEMS INC.

## The Structure of the Galaxian Game Machine

The Galaxian video-game machine has two printed-circuit boards, a motherboard, and a piggyback memory board. The motherboard has a Z80 microprocessor, two 24-pin sockets for the piggyback memory board, and two character ROMs. The character ROMs contain the code for the various images displayed on the screen.

The piggyback memory board has five program ROMs and two sets of 24 pins that fit into the sockets on the motherboard. The program ROMs contain code for the sequence of positions assumed by the images derived from the character ROMs and code for the responses to and interactions with the signals derived from player inputs.

The microprocessor produces signals for the output video display that are derived from (1) the signals coming from player inputs and (2) the code in the ROMs.

When Midway introduced the game machine into the U.S. market and it became a commercial success, importers began to sell competing versions of the game machine with duplicated ROMs. Midway sought to stop this by complaining to the U.S. International Trade Commission (ITC), a federal agency charged with preventing unfair acts and practices and unfair competition in U.S. import trade. The ITC does so by issuing orders prohibiting the importation of products that infringe U.S. patents, trademarks, copyrights, and the like.

The software proprietor sought copyright protection on two aspects of the Galaxian game's display. Midway filed two video tapes with the U.S. Copyright Office, which issued copyright registration certificates to Midway on them as "audiovisual works." The two tapes showed, respectively, output displays of the Galaxian game machine during

(1) the "attract mode" and (2) the "play mode." (Midway did not attempt to register the source program or the object code.)

The "attract mode" of a coin-operated video-game machine is designed to attract customers. It is a short, repeating sequence of a simulated game, similar in effect to a film loop. It fixes as stored data the interaction, on one short occasion, of a skilled player and the code in the ROM. For copyright purposes, what is important is that the attract mode is not input-dependent, but fixed and unvarying in terms of its total content and the sequence in which images appear.

The "play mode" of a video-game machine is the actual game-play sequence, which supersedes the attract mode in a game machine whenever a quarter is inserted into the machine. The play mode display is never quite the same twice, after the first several seconds, for no two player-input signal sets are ever identical. Within any total play mode sequence, however, are certain recurrent subroutines. Any time that an alien insect image contacts the image of the player's Earth-defender rocket ship anywhere on the video screen, an explosion image sequence occurs. This is a set audiovisual display of the mutual destruction of the two images. A similar subroutine is carried out when a player's missile image contacts (hits) an insect image. Moreover, if the game has a background landscape or a maze on which the action is superimposed, that may be a fixed sequence. Games with "characters," such as a protagonist, may have them as fixed sections of code stored in one place.

By way of analogy, to compare the two modes for copyright law purposes, consider an ordinary video tape of *Casablanca*. No matter how many times anyone plays the tape, Rick never gets on the plane to Lisbon, he always shoots Major Strasser, Louis always calls for a roundup of the usual suspects, and Rick and Louis always go off to join the Free French Forces. That is how the attract mode operates. Now, im-

## MicroShell™ conducts your CP/M™ computer with more power than ever before!

### What is MicroShell?

- A normal CP/M program which adds a powerful set of commands to all programs running under CP/M.

### What will MicroShell do?

- Automatic Disk and User Management - Finds your programs from another drive or user number - automatically! Save time and precious disk space.
- Powerful Redirection Capability - Send screen output to a file or printer. Send printer output to a file. Take program input from a file instead of the keyboard.
- Much More - Multiple commands on a line, more powerful and faster "submit" capability, user-definable prompt and many more features.

### Dealers - MicroShell gives you:

- A user-friendly interface to the computer.
- Automatic execution of an application program at startup.
- Self-running demonstrations of your favorite software packages.

### Will MicroShell run on my computer?

- Requires CP/M 2.2. Available on 8" and 5" disks (North Star, Heath, Apple-CP/M, Osborne, SuperBrain and IBM-PC w/Baby Blue.

CP/M™ TM Digital Research, UNIX™ TM Bell Labs, Wordstar™ TM MicroPro, Baby Blue™ TM Xerox, dBase™ TM Ashton Tate

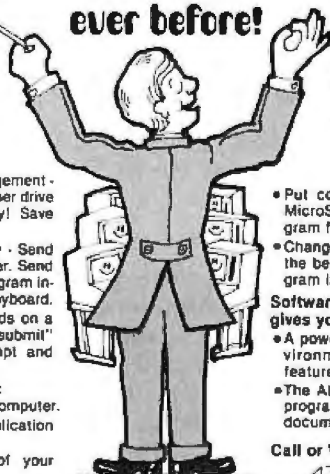

**MicroShell**  
MicroShell \$150.00  
Manual Only \$25.00  
VISA, MC accepted  
VA residents add 4%  
Overseas orders add \$20.00  
for air mail

### Give me some examples!

- Run Wordstar or dBase II from any disk drive or user area.
- Save the screen from a program for later use or to edit into a report. Save printer output in a file.

- Put commands into a file and have MicroShell supply them to the program from the file.
- Change MicroShell's prompt to sound the bell on your terminal when a program is done!

### Software Developers - MicroShell gives you:

- A powerful UNIX-like development environment for CP/M with some features that even UNIX doesn't have!
- The Ability to collect the output of a program in a file and ease the documentation chore.

### Call or Write Today!

**NEW GENERATION SYSTEMS, inc.**

2153 Golf Course Drive  
Reston, Virginia 22091  
Phone: (703) 476-9143

ORDER LINE 800-368-3359

Chances are, when you bought your first disk drive, it was an Apple. Now that you're ready for a second, take a look at Quentin.

Our Apple\*-Mate™ 5¼" Disk Drive is fully software transparent with Apple's DOS 3.3 operating system in full and half track operation.

Add it to your present drive for greater capacity and faster access. Just plug it in and go to work.

And the Apple-Mate has these High Performance advantages:

#### **ON TRACK HEAD SEEK**

A precision lead screw positions the head onto the correct track. Time-consuming retries and disk-to-disk copying errors are virtually eliminated.

#### **SIEMENS† DISK DRIVE**

The apple-beige unit is built around the highly reliable

Siemens system with over 10,000 lifetime hours. Shielded connecting cable also attached.

#### **LONG TERM DEPENDABILITY**

MTBF (Mean Time Between Failures)—8,500 power-on hours, and the unit has a one-year warranty.

#### **COUNT ON QUENTIN FOR QUALITY**

Quentin Research was building disk systems for the computer industry when Apple was a little bud on the big computer tree. We're known for product reliability and stand behind every system we sell you.

But the best news may be the price—only \$335.00 (40 tracks).

A special introductory offer when you order Apple-Mate directly from us.

So when you're ready to boost the juice on your Apple, add-on the Quentin Apple-Mate.

To order: Check, money order, Visa or Mastercard number. Calif. residents add 6% sales tax. Allow one week delivery.



19355 Business Center Drive  
Northridge, California 91324  
(213) 701-1006

# MORE JUICE FOR YOUR APPLE®



**Special  
Introductory  
Price:  
\$335.00**

® Apple is a registered trademark of Apple Computer, Inc.  
†Siemens is a trademark of Siemens Corporation.  
\*Apple-Mate is a trademark of Quentin Research, Inc.,  
which does not manufacture Apple computers.

Circle 395 on Inquiry card.

agine an "interactive" *Casablanca*, an art form of the future, dependent on viewer input. Sometimes Rick gets on the Lisbon plane with Ilsa, sometimes Strasser shoots him first, sometimes Louis arrests Rick, perhaps sometimes Strasser gets Ilsa, and so on. But some recurrent subroutines are also in this *Casablanca*; wherever Rick says, "Play it again, Sam," Sam will always oblige by playing "As Time Goes By" on his piano, and after any shooting, Louis will always say, "Round up the usual suspects." That is how the play mode of a video game may operate.

Midway claimed copyright protection against the importers under both copyright registrations. The ITC agreed that the copyright on the Galaxian attract mode "audiovisual work" had been infringed because the importers simply unloaded and reloaded the whole ROM without bothering to identify and vary the fixed data stored in the attract mode portion of the ROM. This caused the importers' machines to duplicate or perform the very same attract mode performed by Midway's machines, which was infringement of Midway's copyright on the attract mode. But the ITC refused to rule on whether Midway could also gain protection on the basis of the importers' unloading and reloading the play mode's program data (object code) from the ROM. (*Certain Coin-Operated Audio-Visual Games and Components Thereof*, ITC Docket No. 337-TA-87, Opinion of June 26, 1981.)

First, the ITC said that registering a video tape of a single play mode performance of the Galaxian game is not a registration of every other possible Galaxian game performance. Since there are millions of possible Galaxian play mode performances, allowing registration of one performance to confer protection for the entire set of possible performances would be the equivalent of copyrighting the idea of the Galaxian game itself. But the copyright laws do not allow games or other ideas to be protected as such. In short, although the ITC did not put it in these terms, registering one com-

puter run of a program or one output display does not constitute registering a claim of copyright on all runs, all displays, or the algorithm (or program) for all runs.

Second, the ITC said that the human player is perhaps a coauthor of the Galaxian play mode performance or output. The ITC asked: Can a work coauthored by a person and a computer (the Galaxian game machine with its processor, ROM, etc.) be protected by the computer owner's copyright? The ITC refused to answer this difficult question because it believed that the narrow basis on which it had decided to dispose of the case permitted it to avoid the issue.

---

**It is unfair to duplicate object code because doing so violates the spirit of the copyright laws even though not their letter.**

---

The ITC found a way to decide the case that made it possible not to rule on such difficult legal questions as whether the program for the Galaxian play mode or ROM had been, or could in any way be, copyrighted or infringed. The importers had all copied the attract mode, which was protected as a copyrighted audiovisual work. Their machines could therefore be excluded from the U.S. on that ground alone. The other more difficult questions could, if necessary, be decided in subsequent cases involving other video games. (One such case is now pending before the ITC.)

Finally, the ITC noted that its disposition of the Galaxian case made it unnecessary to reach an issue urged upon it by the present writer. This was whether it was unfair to unload and reload program data (object code) from a ROM even though it was not copyright infringement to do so. In the view that the writer urged, it is unfair to duplicate object code (as the ITC statute uses the term "unfair") because doing so violates

the spirit of the copyright laws even though not their letter. Understandably, the ITC may have felt reluctant to fill in a gap in the copyright laws when Congress had failed to do so. Despite its avoidance of many important issues, the ITC's opinion in the Galaxian case is perhaps the most perceptive and instructive one in the whole object code/unloaded-ROM field.

**The TRS-80 Case:** The latest lawsuit over object code involves the input/output (I/O) interpreter program for the TRS-80 microcomputer. (*Tandy Corp. v. Personal Micro Computers, Inc.*, 524 F. Supp. 171 [N.D. Calif. 1981].) Tandy's TRS-80 microcomputer includes an I/O program stored in a ROM. The TRS-80 I/O program interprets BASIC source code into machine-intelligible object code. This interpretation process is essential to the use of the computer, the trial court noted, because human beings using the TRS-80 cannot understand and communicate object code, while machines cannot understand (by that term, the court meant cannot be directly operated by means of) a human-intelligible, high-level language such as BASIC source code. Of course, the same principle applies to the I/O program itself. It, too, must be transformed into object code before the computer can understand and use it. Tandy therefore compiled the I/O program and loaded it into a ROM, which was placed in its TRS-80s. This was a ROM whose silicon chip's physical pattern corresponded to the object-code form of the I/O program. (Presumably, this was a custom ROM, not a PROM, but that does not seem material to copyrightability.)

Tandy had apparently registered the program for copyright as a source program. Tandy sued the defendant, also a manufacturer of microcomputers, when it discovered that the defendant had unloaded the ROM and was using the program in its microcomputers. Tandy's I/O program was presumably copyrightable when it was written out in BASIC source code or another human-

# PERSYST

FOR THE **IBM**® PERSONAL COMPUTER

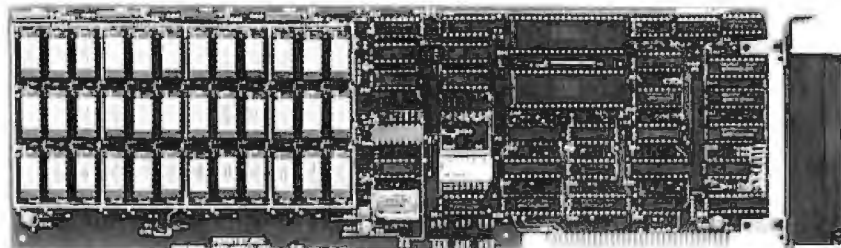
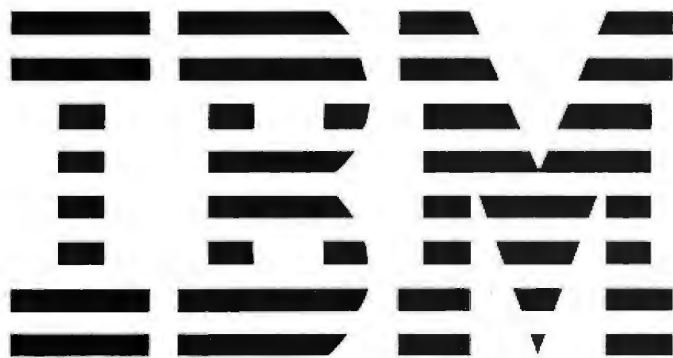

**SPECTRUM**  
Multifunction  
Board

**FOUR**  
**FUNCTIONS**  
**INDEPENDENTLY**  
**UPGRADEABLE**

## Memory Expandable RAM

- Expandable from 64 to 256K Bytes
- Parity generate and check
- Base address switch-selectable for any 64K boundary
- No wait states

## Expandable Parallel Printer Port

- Supports Centronix, Data Products or IDS interface
- Switch selection of printer port I/O address
- Selectable Interrupt level
- Adjustable flat cable clamp (strain relief)

## Two Expandable Asynchronous Communication Ports

- Single or Dual Channel, RS 232-C
- DCE/DTE selectable
- 3 wire interface support
- Full modem support
- Programmable Baud rates from 50 to 19,200
- Selectable Interrupt levels
- Programmable character length, stop bits and parity
- Single line configuration addressable as COMM 1 or COMM 2

**PERSONAL SYSTEMS TECHNOLOGY, INC.**

22957 LA CADENA LAGUNA HILLS, CA. 92653 (714) 859-8871

## Object Code, Piano Rolls, and Sanskrit

Some programmers claim to be able to read object-code printouts. It is unclear, under copyright law, how many people must be able to read a message for it to be deemed a copyrightable "writing" or a "copy." In one case, now of questionable authority, the U.S. Supreme Court held that perforated player-piano rolls were not "copies." Thus, they were not infringements of copyrighted sheet music, even though some persons skilled in making piano rolls claimed to be able to read them as others read ordinary musical staff notation. The Court pointed out that, in any event, a piano roll is not intended to be read like sheet music. Moreover, it noted, extending similar protection to piano rolls as "copies" would require extending similar pro-

tection to music-box cylinders and other mechanical objects, an extension of copyright law that the Court considered improper.

On the other hand, it is generally believed that a book written in Sanskrit or a listing of a source program in FORTRAN or APL may be copyrighted, even though relatively few persons can read them. Copyright protection has even been granted to a book of meaningless five-letter "words" intended for use as cable code, where the users were supposed to supply their own arbitrary meanings for the "words."

Opinions probably differ widely among lawyers as to whether intelligibility of the message to a large number of persons is a requisite of copyright.

intelligible language. But the defendant had duplicated the ROM, not the source code. This raised the question, as in the Compuchess case, whether Tandy's or the defendant's ROM chip was a "copy" (as the copyright statute uses that term) of the copyrighted TRS-80 I/O program. The defendant moved for a pretrial summary judgment in its favor on the ground that regardless of whether its ROM duplicated Tandy's ROM it was not a "copy" of Tandy's copyrighted I/O program.

The court rejected the motion, refused to dismiss Tandy's complaint, and said that the case must go to trial. Its reasoning was as follows:

•The statute says that works can be "fixed" by embodying them in any "tangible medium of expression, now known or later developed, from which they can be perceived, reproduced, or otherwise communicated, either directly or with the aid of a machine."

•A silicon chip is a "tangible medium of expression" within the meaning of the copyright statute.

•"The imprinting of a computer program on a silicon chip, which then allows the computer to read the program and act upon its instructions, falls easily within this definition" of "fixed."

•Therefore, the copyright laws protect a program fixed in the form of a ROM chip. Unloading and reloading a ROM is copyright infringement of the copyright on the source program.

The court recognized that in the Compuchess case the trial court had held the opposite. But it simply disagreed with that court's reasoning and refused to follow it.

The court's conclusions in the TRS-80 case about copying ROMs do not seem to follow properly. There appear to be some gaps in the court's logic, which it has filled with unstated and perhaps incorrect assumptions. The court's remarks about the program being "fixed" in the ROM chip ignore (1) the statute's requirement that a "copy" of the program be made before an infringement can be found, and (2) the problems stemming from the fact that the statutory definition of "fixed" parallels the statutory definition of "copies," so that the various legal problems do not go away by focusing only on "fixed."

## SOFTWARE COMPATIBLE MACHINES CP/M and TRSDOS

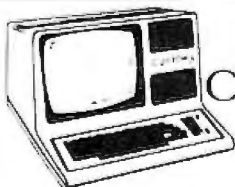

Custom 3

MOD III & CP/M SOFTWARE COMPATIBLE  
DUAL 40 TRACK 5¼" DISK DRIVES  
8" DRIVE CONTROLLER  
1 YEAR WARRANTY

48K .....\$2,233.00  
64K ..... 2,449.00

OTHER DRIVE CONFIGURATIONS AVAILABLE INCLUDING INTERNAL HARD DISK

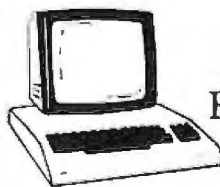

LNW  
Research

MOD I & CP/M SOFTWARE COMPATIBLE  
DUAL 40 TRACK 5¼" DISK DRIVES  
8" DRIVE CONTROLLER—HI-RES &  
COLOR GRAPHICS 4 Mhz SPEED—Z80A  
PROCESSOR—FAN

48K .....\$2495.00  
96K ..... 3095.00  
48K without  
CP/M ..... 2295.00

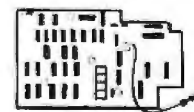

Freedom  
Boards

CP/M CONVERSION BOARDS FOR  
THE TRS-80 AND LNW COMPUTERS  
FROM FREEDOM TECHNOLOGY  
INTERNATIONAL

Freedom Option ....\$222.00  
Freedom Plus ..... 444.00  
-adds 16K of RAM

## MERIDIAN

119 N. 18th Street Phila., PA 19103  
(215)-569-2420

Tandy Corp.—TRS-80, TRSDOS Digital Research—CP/M



# SHOPPER STOPPERS

MAIL COMP HAS THE PRICE, SELECTION  
AND FAST DELIVERY ON MAJOR BRANDS,  
ACCESSORIES AND SOFTWARE!



APPLE SPECIALS	
* SPELLGARD BY INNOVATIVE SOFTWARE	\$ 195
UPPER LOWER CASE ROM	19
16K MEMORY CARD	76
PARALLEL INTERFACE CARD	55

\* Requires Z80 Card by Microsoft or Z Card by Innovative Software

ATARI	
ATARI 400 (16K)	349
ATARI 800 (16K)	675
ATARI 810 DISK DRIVE	445
ATARI 850 INTERFACE	169

TEXAS INSTRUMENTS	
TI 99/4	399
TI SOLID STATE PRINTER	299
TI 10" COLOR MONITOR	342

NEC	
PC-801A CPU	839
PC-8012A I/O	535
PC-8033A DISK I/O	150
PC-8031A DUAL DISK	839

FRANKLIN ACE 100	CALL
XEROX B20	CALL

PRINTERS	
OKIDATA 80A	\$ 360
OKIDATA 82A	529
OKIDATA 83A	749
OKIDATA 84	1,089
OKIDATA 84S	1,149
EPSON MX70	349
EPSON MX80 W/ GRAFTRAX	470
EPSON MX80FT W/ GRAPHICS	569
EPSON MX100FT W/ GRAPHICS	729
NEC 3510/3830	1,750
NEC 7710 7730	2,350
NEC 8023 W/TRACTORS	489
DIABLO 630	1,995
AMADEK 9501	1,290
C ITOH PROWRITER PARALLEL	499
C ITOH PROWRITER SERIAL	649
C ITOH COMET II PARALLEL	795
BROTHER HR-1 D/W PARALLEL	CALL
BROTHER HR-1 D/W SERIAL	CALL
IDS PRISM 80 W/O COLOR	919
IDS PRISM 80 W/COLOR	1,385
IDS PRISM 132 W/COLOR	1,889

MONITORS/TERMINALS	
AMDEK 12" GREEN	\$ 199
AMDEK 12" COLOR	379
AMDEK COLOR II	769
AMDEK COLOR III	475
TELEVIDEO 910	575
TELEVIDEO 912	695
TELEVIDEO 925	729
TELEVIDEO 950	925
NEC 12" COLOR	325
NEC 12" GREEN	169
ADDS VIEWPOINT GREEN	649
ADDS VIEWPOINT 60	695
HAZELTINE ESPRIT	585
HAZELTINE ESPRIT II	849
SANYO 12" B/W	249
SANYO 12" GREEN	259
SANYO 13" COLOR	425
SANYO 13" COLOR RGB	985
BMC 12" GREEN	95
BMC 12" HI RES	145
BMC 14" RGB COLOR	339

MODEMS	
NOVATION CAT	\$ 145
NOVATION O CAT	155
NOVATION AUTO CAT	209
NOVATION APPLE CAT	299
HAYES SMARTMODEM	245
HAYES MICROMODEM II	279
HAYES MICROMODEM 100	325
HAYES CHROMOGRAPH	225
LEXICON II MODEM	125

ACCESSORIES	
* 16K MEMORY CARD	\$ 76
* 32K MEMORY CARD	139
* 16 32 EXPANDABLE MEMORY CARD	119
* UPPER LOWER CASE ROM	19
* SERIAL I/O CARD	99
* PARALLEL INTERFACE CARD	69
* PROM II™ EPROM	99
* TFMAC PARALLEL INTERFACE W/ GRAPH	84
* GRAFTRAX PARALLEL INTERFACE W/ GRAPH	98
* OKIGRAPH OPTION FOR 82A 83A	49
* GRAFTRAC II	20
EPSON RS 232 INTERFACE BOARD	88
EPSON RS 232 INTERFACE W/ 2K	125
EPSON IEEE 488 INTERFACE BOARD	69
EPSON TS 80 EXP INTERFACE CABLE	69
* Z 80 SOFTCARD BY MICROSOFT	269
* ROM WRITER	130
* THE CLOCK	225
* CPS MULTIFUNCTION	185
* RAMPLUS 16K	136
* RAMPLUS 32K	152
* MUSIC SYSTEM	319
* Z-CARD FOR APPLE II	275
* SUP R MOD II TV INTERFACE	36
SUP R TERMINAL & COL VIDEO BOARD	318
* APPLE PRINTER INTERFACE CARD	88
* APPLE PARALLEL INTERFACE CABLE	29
ROLL PAPER HOLDER FOR MX 80	21
* AMDEK DVM INTERFACE BOARD FOR APPLE II	189
* MICROBUFFER II 16K FOR APPLE II	199
* MICROBUFFER II 32K FOR APPLE II	239
8K SERIAL BUFFER FOR EPSON PRINTER	129
16K PARALLEL INTERFACE FOR EPSON	129

\* For Apple II

APPLE II SOFTWARE	
VISICALC	\$ 185
VISIFILE	185
VISIPLOT	155
VISITREND VISIPILOT	225
VISITERM	75
VISIDEX	185
VISISCHEDULE	235
DESK TOP PLAN II	185
VBI-PACK	549
* VPROSTAR	195
* SPELLSTAR	125
* DATASTAR	192
* MAILMERGE	80
* SUPERSORT	125
* CALCSTAR	129
OLYMPIC DECATHLON	26
BASIC COMPILER	315
FORTRAN 80	165
COBOL 80	595
TASC	189
SELECT W/P BY SELECT	359
SUPERCALC BY SORCIM	185
CCA DATA MANAGEMENT SYSTEM	79
TYPIST TUTOR I	25
ADVENTURE	18
ms MATH ms SIMP 80	200
M SORT	156
A.L.D.S	88
SOFTCARD PREMIUM SYSTEM	599
TIME MANAGER	140
d BASE II	493
SPELLGARD	195
DATA FAX	139
STEP BY STEP (TAPE)	59
DATA CAPTURE	45

\* Requires Z80 Card by Microsoft or Z Card by Innovative Software

CP/M SOFTWARE	
SUPERCALC BY SORCIM	\$ 195
WORDSTAR	289
CALCSTAR	189
DATASTAR	225
SUPERSORT	169
MAILMERGE	80
SPELLSTAR	149
BASIC 80	280
BASIC COMPILER	319
COBOL 80	595
FORTRAN 80	368
MACRO 80	169
ms MATH ms SIMP 80	219
ms LISP ms STAR 80	175
PL I-80 BY DIGITAL RESEARCH	435
ACCOUNTING PLUS	CALL
dBASE II	499
CROSSTALK	109
QUICKSCREEN	125
THE WORD	65
SPELLBINDER	249
T MAKER II	195
SUPERVIZE	69
CONDOR II	449
SELECT WORK PROCESSOR	369
TIM II	408
M SORT	156

ATARI SOFTWARE	
VISICALC DISK	\$ 189
PACMAN CART	35
CENTPEDE CART	35
WORK PROCESSING DISK	119
CAVERNS OF MARS DISK	31
PERSONAL FINANCIAL MANAGEMENT DISK	55
ENTERTAINER KIT - CART	79
PROGRAMMER KIT - CART	55
EDUCATOR KIT - CART	125
COMMUNICATOR KIT - CART	335
DOW JONES INVESTMENT DISK	99
ASTEROID by ONLINE DISK	29
APPLE PANIC by BUDGECO DISK	23
ZORKII by INFOCOM DISK	29
RASTER BLASTER by BUDGECO DISK	23
BUG ATTACK by CAVALIER	23

IBM SOFTWARE	
SUPERCALC	\$ 195
SELECT WORK PROCESSOR W SUPERSPELL	359
VISICALC 256K VERSION	185
WORDSTAR	249
MAILMERGE	80
DATASTAR	225
CALCSTAR	189
TIM II	408
SPELLGARD	195
CONDOR II	449
EASYSPELLER	125
EASY WRITER II	249
CROSSTALK	109

WE ACCEPT

- PERSONAL CHECK (allow 10 days to clear)
- VISA MASTERCARD (add 2%)
- CASHIERS or CERTIFIED CHECK
- MONEY ORDER
- BANK WIRE TRANSFERS
- COD

Add 3% for shipping, handling & insurance (85 min) Cash residents add 8% tax. All equipment is new comes with manufacturers guarantees. PLUS we guarantee it for 30 days and pay shipping charges on any returns. All equipment subject to price change & availability without notice. Check quantity discounts.

\* APPLE II IS A REGISTERED TRADEMARK OF APPLE COMPUTER, INC.  
\* CP/M IS A REGISTERED TRADEMARK OF DIGITAL RESEARCH.

FREE CATALOG

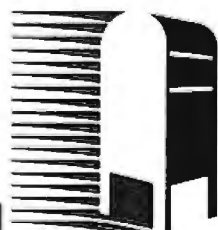

mail  
comp

Circle 280 on inquiry card.

Mailcomp, Inc.  
8380 Miramar Road, Suite 200  
San Diego, CA 92126  
FREE SHIPPING (ON PRE-PAID CASH ORDERS)  
Call Collect: 714-578-1033



# SUPERBRAIN™

The super performing, super reliable microcomputer from Intertec Data Systems features twin double-density 5¼" drives with 350K or 700K of disk storage – expandable to 10 megabytes. A CP/M\* Disk Operating System, 64K of dynamic RAM and more.

## \$ SUPER PRICE

Because we're a nationwide distributor of SuperBrain, CompuStar, and the CompuStar 10-Megabyte Disk Storage System, we can offer the absolute lowest prices in the business.

## ⚡ SUPER SERVICE

Better yet, we offer you a great deal of service and support because we want your business tomorrow as well as today.

- We'll burn-in your SuperBrain for 72 hours before we deliver it
- We'll help with installation and configuration
- We'll repair equipment at our service center and replace modules when necessary
- We'll fill your software needs or help you develop your own
- We'll match your SuperBrain with a super printer

For more information call 609-424-4700 or 215-629-1289. To order call toll-free 800-257-5217. In NJ call 609-427-4700.



2 Keystone Avenue  
Cherry Hill, NJ 08003

\* Registered trademark of Digital Research Inc. SuperBrain and CompuStar are trademarks of Intertec Data Systems.



Worst of all, the court seems to have badly confused itself with its metaphors. The court speaks of a computer's "reading" or "understanding" object code, and "act[ing] upon its instructions," analogously to a person's reading or understanding a source program or other literary work. But the court mistakes its figure of speech for reality. Computers and other machines do not *read* books or *understand* them in the same sense as a person does. Yet, the court's reasoning assumes this. Thus, "perception" by a machine or "communication" to a machine is assumed to be covered by the statute. But that needs to be decided, not assumed. The terms "perceived" and "communicated" in the statutory definitions of "copies" and "fixed" may well contemplate nothing of the kind. Probably, the opposite assumption would be sounder.

This flushes out the basic issues in the unloaded-ROM cases:

- whether under the present statute, "human intelligibility" is a requirement for copyright
- whether copyright can be used to protect objects intended to perform a utilitarian function rather than to act as a medium for communicating ideas

Those are the real points of difference, whether well articulated or not, between the two courts in the *Compuchess* and *TRS-80* cases, and they underlie the issues that the ITC considered too troublesome to decide in the *Galaxian* case.

### Protecting Software Under Present Law

If one had to choose only among expanding the laws governing copyrights, patents, trade secrets, or contracts, copyright would probably be the best of a bad lot. But it is a poor second to a specific software law based on the broader power of Congress to regulate commerce than to regulate "writings." Perhaps the best way to understand this is to briefly survey the concepts and structures of those respective bodies of law, focusing first on how they apply to software and then on specific software problems that are not dealt with

satisfactorily. The purpose of the following overview is to show how the structure and concepts of copyright, patent, trade secret, and contract law relate to the things they were evolved to deal with, and how they much less satisfactorily relate to software.

### What Does the Copyright Act Do for Software?

The three unloaded-ROM cases indicate that the copyright laws furnish object code with little protection, debatable protection, or no protection at all. The present copyright statute, despite two amendments, has probably bungled the protection of object code. Despite optimistic claims that "the copyright problem was resolved by the Computer Software Copyright Act of 1980" and "object code is now clearly subject to copyright laws" (see *BYTE*, May 1981, pages 130, 138), the reality is that "subsequent revision (most particularly the Computer Software Copyright Act of 1980) continues to provide inadequate protection" (*BYTE*, May 1981, page 138).

**Copies:** True, the 1980 Act contains a definition of "computer program" that at least arguably includes object code (see *BYTE*, May 1981, page 130). But the Act stops there and does not go on to say that unloading a program from a ROM or otherwise electronically duplicating a program (specifically, object code) constitutes unlawful copyright infringement or the making of a forbidden "copy." That further step is essential to our having secure copyright protection for object code if the following analysis is correct.

The copyright statute is a maze—or certainly a very complex network. The copyright statute has a key node through which every important signal must pass. This is the definition of "copy." Only a "copy" of a work can be protected; only a "copy" of a work is an infringement. The statute defines a "copy" of a program or other work as a stable, tangible embodiment of the work from which the work "can be perceived . . . or otherwise communicated." The quoted words may well compel the conclu-

**LOOK!**  
 14.4 MEGABYTES  
 UNFORMATTED  
 11.3 MEGABYTES  
 FORMATTED



**LOOK!**  
 \$2495  
 Complete  
 Subsystem

### INEXPENSIVE MASS STORAGE

Gallium 10, 20, 30 & 40 megabyte disk systems are the **MOST** cost-effective winchester disk systems for your Apple® II computer.

The Gallium-10 is available in a 10 Mbyte configuration for an introductory price of **\$2495**.

### GALLIUM IS VERY ECONOMICAL

For the price of 4 disk drives you can have the capacity of 72 diskettes and our Volumes are 3 Apple diskettes' capacity. That means you can have over 400 kilobytes files without segmenting your data base.

With our intelligent controller you can expand to 40 megabytes with the addition of 3 more 10 Megabyte drives.

We use proven winchester disk technology to assure you of the finest quality disk drive your money can buy. The disk drive operation is **NOISE-FREE** for office and home environments.

### GALLIUM SOFTWARE

The Rom-resident software interfaces to DOS 3.3, Apple Pascal (optional) and CP/M (optional). All operating systems remain unmodified so there is no need to change anything in your programs to use the Gallium-10.

Utilities provided include programs to copy from floppy to Gallium and from Gallium to floppy, format volumes, and a demo program to show you how your disk can be used.

### SERVICE

Gallium-10 disk drives come with a 90-day parts & labor warranty. An extended warranty is available

at extra cost. Gallium disk systems require no preventive maintenance.

### SPECIFICATIONS:

#### DATA ORGANIZATION

Capacity (Megabytes)  
 Unformatted ..... 14.4 Megabyte  
 Formatted ..... 11.3 Megabyte

#### DISKS

Number ..... 3  
 Data Surfaces ..... 6  
 Diameter (Inches/cm) ..... 5.25/13.33

#### PERFORMANCE

Access Time Track To Track (3 milliseconds)  
 Disk Rotational Speed ..... 3600 rpm  
 Peak Transfer Rate ..... 5 MB/S

#### UTILITIES

Format ..... Formats All Surfaces  
 Volume Initer ..... Initializes With An "EMPTY" File  
 A Given Number Of Volumes  
 File Finder ..... Finds All Volumes On Which  
 Any Given File Is Resident  
 File Runner ..... Finds & Runs The Given File  
 From The First Volume On  
 Which It Is Resident  
 Partition ..... Partitions The Disk For DOS 3.3,  
 CPM & PASCAL Allocating  
 The Required Number Of Sectors  
 For Each Given Operating System  
 CPM Boot ..... Permits Booting  
 In CPM Operating System  
 PASCAL Boot ..... Permits Booting In PASCAL  
 Connect ..... Connects Gallium To DOS  
 If Booted From Floppy Disk

\* Apple is a registered trade mark of Apple Computer Co.

# XITENSYSTEMS

16815 Hawthorne Blvd. • Lawndale, CA 90260 • (213) 370-3966  
 (800) 421-1947

# As your introduction to **The Library of Computer and Information Sciences**

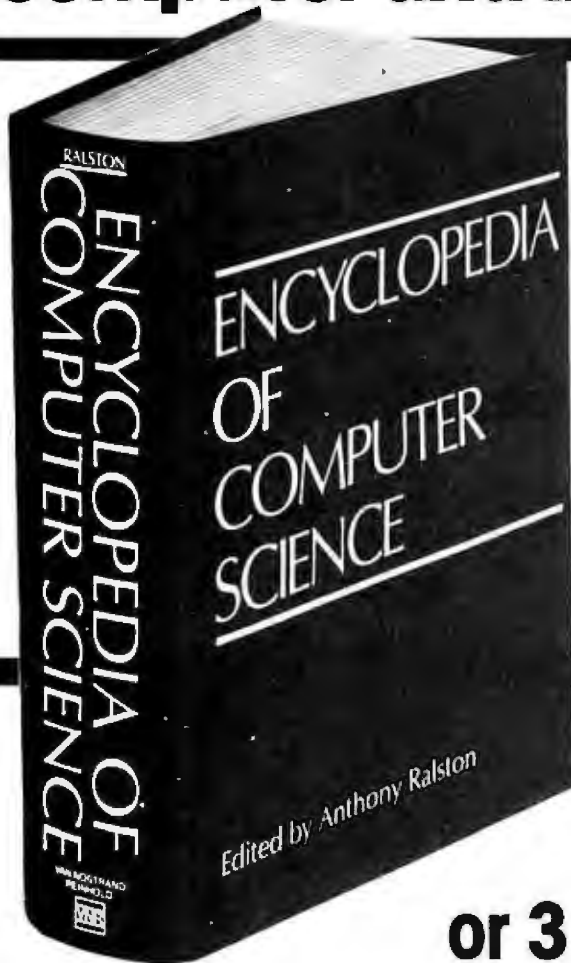

## Take this

# \$60.00 classic for only \$3.00!

### ENCYCLOPEDIA OF COMPUTER SCIENCE

Edited by Anthony Ralston. More than 1550 oversized pages of information on every aspect of computer science—from algebra to automata theory, from basic terminology to string processing languages. 470 articles by 208 experts. Over 700 charts, tables, graphs, and diagrams.

## or 3 other books for only \$1 each (values to \$74.95)

You simply agree to buy 3 more books—at handsome discounts—within the next 12 months.

(Publishers' Prices shown)



**58811. LOGICAL CONSTRUCTION OF SYSTEMS.** Jean-Dominique Warnier. Covers every aspect of system design, from the specification of data to the final dialogue between designers and users. **\$22.95**



**42000-2. DESIGN AND STRATEGY FOR DISTRIBUTED DATA PROCESSING.** James Martin. Coverage of the impact of DDP on the ultimate users of a system, the office-of-the-future concept and much more. Counts as 2 of your 3 books. **\$37.50**

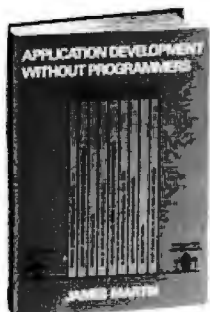

**34133-2. APPLICATION DEVELOPMENT WITHOUT PROGRAMMERS.** James Martin. A look at major changes in which "packaged" routines deliver application software to order. Counts as 2 of your 3 books. **\$32.50**



**32485. ALGORITHMS + DATA STRUCTURES = PROGRAMS.** Niklaus Wirth. "A valuable, novel contribution to the computing science literature." — Edsger Dijkstra. **\$20.95**

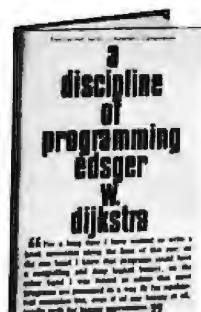

**42303. A DISCIPLINE OF PROGRAMMING.** Edsger W. Dijkstra. Program derivation and composition, common mistakes plus numerous other examples. **\$25.00**

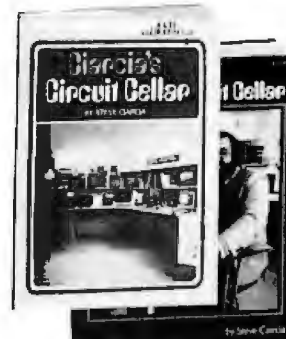

**37980. CIARCIA'S CIRCUIT CELLAR: Volumes I and II.** Steve Ciarcia. Over a year's worth of Ciarcia's most popular microcomputer articles from BYTE. Softcover. **\$20.95**

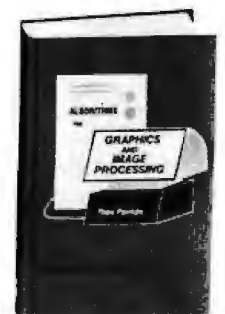

**32487-2. ALGORITHMS FOR GRAPHICS AND IMAGE PROCESSING.** Theo Pavlidis. A comprehensive handbook covering everything from pattern recognition to image segmentation packed with charts, diagrams, and equations. Counts as 2 of your 3 books. **\$26.95**

## The Library of Computer and Information Sciences

Please accept my application for trial membership and send me the three volumes indicated, billing me only \$1.00 each. I agree to purchase at least three additional Selections or Alternates over the next 12 months. Savings range up to 30% and occasionally even more. My membership is cancelable any time after I buy these three books. A shipping and handling charge is added to all shipments.

**3 books for \$1.00 each.** Indicate by number the books you want.

--	--	--

A few expensive books (noted in the book descriptions) count as more than one choice.

**No-Risk Guarantee:** If you are not satisfied—for any reason—you may return your 3 books within 10 days and your membership will be canceled and you will owe nothing.

Name \_\_\_\_\_

Name of firm \_\_\_\_\_  
(if you want subscription sent to your office)

Address \_\_\_\_\_

City \_\_\_\_\_

State \_\_\_\_\_ Zip \_\_\_\_\_

(Offer good in Continental U.S. and Canada only. Prices slightly higher in Canada.)

Byte 9/82

7-8K3

## The Library of Computer and Information Sciences

Please accept my application for trial membership and send me the three volumes indicated, billing me only \$1.00 each. I agree to purchase at least three additional Selections or Alternates over the next 12 months. Savings range up to 30% and occasionally even more. My membership is cancelable any time after I buy these three books. A shipping and handling charge is added to all shipments.

**3 books for \$1.00 each.** Indicate by number the books you want.

--	--	--

A few expensive books (noted in the book descriptions) count as more than one choice.

**No-Risk Guarantee:** If you are not satisfied—for any reason—you may return your introductory books within 10 days and your membership will be canceled and you will owe nothing.

Name \_\_\_\_\_

Name of firm \_\_\_\_\_  
(if you want subscription sent to your office)

Address \_\_\_\_\_

City \_\_\_\_\_

State \_\_\_\_\_ Zip \_\_\_\_\_

(Offer good in Continental U.S. and Canada only. Prices slightly higher in Canada.)

Byte 9/82

7-BM3



NO POSTAGE  
NECESSARY  
IF MAILED  
IN THE  
UNITED STATES

**BUSINESS REPLY CARD**

FIRST CLASS PERMIT NO. 230 RIVERSIDE, N J

POSTAGE WILL BE PAID BY ADDRESSEE

**The Library of Computer  
and Information Sciences**  
Riverside, New Jersey 08075



NO POSTAGE  
NECESSARY  
IF MAILED  
IN THE  
UNITED STATES

**BUSINESS REPLY CARD**

FIRST CLASS PERMIT NO. 230 RIVERSIDE, N J

POSTAGE WILL BE PAID BY ADDRESSEE

**The Library of Computer  
and Information Sciences**  
Riverside, New Jersey 08075

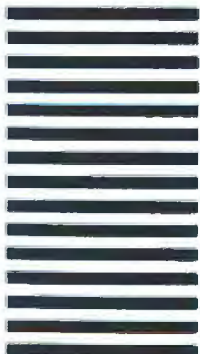



**54425. IDA: A User's Guide to the IDA Interactive Data Analysis and Forecasting System.** Ling and Roberts. An essential handbook that explains how to use the IDA package. **\$12.50**



**45043. AN END-USER'S GUIDE TO DATA BASE.** James Martin. An excellent primer for the lay person by the world's best-selling computer author. **\$23.00**



**76120. THE SCIENCE OF PROGRAMMING.** David Gries. Complete methodology for program development in such areas as: propositions, semantics of small language and more. Soft-cover. **\$19.80**

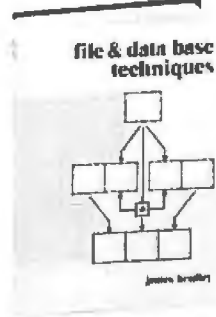

**48496-2. FILE & DATA BASE TECHNIQUES.** James Bradley. Includes everything from file handling to CODASYL data base standards, from hierarchical data base design to cost benefit analysis of a data base structure. Counts as 2 of your 3 books. **\$26.95**

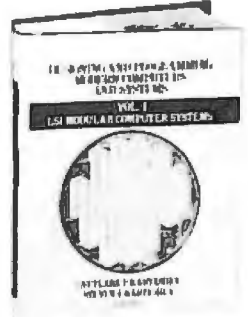

**42057-2. DESIGNING AND PROGRAMMING MODERN COMPUTERS AND SYSTEMS, Volume I.** Svetlana and Steven Kartasher. This comprehensive volume spells out the effects of large scale integration methodology and technology on design thinking. Counts as 2 of your 3 books. **\$37.50**

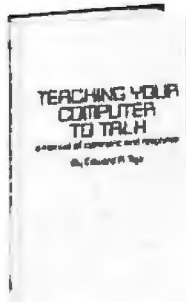

**82522. TEACHING YOUR COMPUTER TO TALK.** Edward R. Teja. A fact-filled guide to voice equipment for computers. **\$15.95**

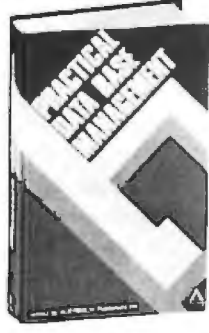

**69747. PRACTICAL DATA BASE MANAGEMENT.** Ed. by Auerbach Publishers, Inc. A comprehensive look at how to deal with everything from basic requirements planning to fine-tuning an existing data base, and much more. **\$24.95**

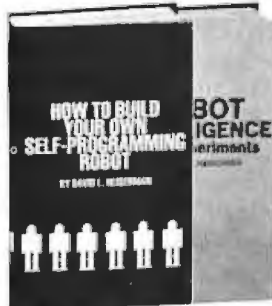

**53677-2. HOW TO BUILD YOUR OWN SELF-PROGRAMMING ROBOT IN TELLIGENCE... WITH EXPERIMENTS.** David L. Heiserman. Two books which count as 2 of your 3 books. **\$29.90**

## Plus more books to choose from

**41628-2. DATABASE: Structured Techniques for Design, Performance and Management.** S. Aitre. Spells out how to plan, design and maintain a large data base for batch and on-line operations. 444 pages. Counts as 2 of your 3 books. **\$29.95**

**51955-2. A GUIDE TO THE SUCCESSFUL MANAGEMENT OF COMPUTER PROJECTS.** Hamish Donaldson. Provides invaluable advice on project management and documentation, systems design strategy, and programming. Counts as 2 of your 3 books. **\$34.95**

**79155. SOFTWARE INTERPRETERS FOR MICROCOMPUTERS.** Thomas C. McIntire. How to design a reliable software interpreter for any microcomputer system. **\$23.95**

**40045-2. CONVERSATIONAL LANGUAGES.** Kupka and Wilsing. Includes interactive program development, languages based on JOSS, syntax and design of conversational languages and more. Counts as 2 of your 3 books. **\$27.75**

**53679. HOW TO DESIGN, BUILD AND PROGRAM YOUR OWN ADVANCED WORKING COMPUTER SYSTEM.** Robert P. Haviland. A practical construction and design guide. **\$16.95**

**42420. THE DISTRIBUTED SYSTEM ENVIRONMENT: Some Practical Approaches.** Grayce M. Booth. Covers horizontal and hierarchical distributed structures, networking and much more. **\$21.95**

**58634. LISP.** Winston and Horn. Shows basic LISP functions, definitions, conditions, and scoping, recursion and iteration. Soft-cover. **\$15.95**

**85723. USING THE UNIX SYSTEM.** Richard Gauthier. A guide to the many program development features of the UNIX system. **\$18.95**

**49355. FUNDAMENTALS OF DATA STRUCTURE.** Ellis Horowitz and Sartaj Sahm. A practical handbook outlining the principles of data structure design and manipulation. Includes in-depth coverage of file organizations, indexing techniques, internal and external sorting and tree structures. With detailed illustrations. **\$23.95**

**48494. FILE TECHNIQUES FOR DATA BASE ORGANIZATION IN COBOL.** Johnson and Cooper. Includes technical considerations in choosing a file structure, data structures and more. **\$20.95**

**81857. SYSTEMATIC PROGRAMMING.** Niklaus Wirth. A classic work on programming as an exercise in constructing algorithms by the noted author. **\$23.95**

**40060-2. COMPUTER SYSTEMS ARCHITECTURE.** Jean-Loup Baer. Looks at everything from stack architectures to orthogonal instruction sets, from hierarchic systems to distributed systems and more. Counts as 2 of your 3 books. **\$26.95**

**63214. MULTI-NATIONAL COMPUTER SYSTEMS: An Introduction to Transnational Data Flow and Data Regulation.** Harry S. Katzman, Jr. A look at how we can balance growing technology with human rights in the international arena. **\$16.95**

**39965. COMPUTER CAPACITY: A Production Control Approach.** Melvin J. Strauss. Provides the formulas and the strategies necessary to make accurate estimates of computer usage demands. **\$24.95**

**51980. A GUIDE TO STRUCTURED COBOL WITH EFFICIENCY TECHNIQUES AND SPECIAL ALGORITHMS.** Pacifico A. Lim. Methods, short-cuts, and approaches to more efficient coding techniques. **\$18.95**

If the reply card has been removed, please write to The Library of Computer and Information Sciences Dept. 7-BK3, Riverside, N.J. 08075 to obtain membership information and application.

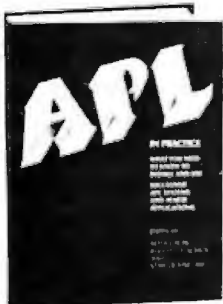

**34115. APL IN PRACTICE.** Edited by Allen J. Rosen et al. Covers such topics as writing maintainable APL codes, evaluating telecommunications networks, using APL for construction accounting and more. **\$25.00**



**73246. QUEUEING THEORY: A Problem Solving Approach.** Leonard Gorney. Covers Stochastic, Markov and Poisson processes, queue structure, discipline, length and more. **\$21.95**



**36957-2. BUILD PROGRAM TECHNIQUES.** John G. Rice. Provides a framework for the design, development and implementation of Automatic Software Generation Systems (ASGS). Counts as 2 of your 3 books. **\$29.95**

## 4 Good Reasons to Join

**1. The Finest Books.** Of the hundreds of books submitted to us each year, only the very finest are selected and offered. Moreover, our books are always of equal quality to publishers' editions, never economy editions.

**2. Big Savings.** In addition to getting either the Encyclopedia of Computer Science for \$3.00, or 3 books for \$1.00 each when you join, you keep saving substantially, up to 30% and occasionally even more. (For example, your total savings as a trial member, including this introductory offer, can easily be over 50%. That's like getting every other book free!)

**3. Bonus Books.** Also, you will immediately become eligible to participate in our Bonus Book Plan, with savings up to 70% off the publishers' prices.

**4. Convenient Service.** At 3-4 week intervals (16 times per year) you will receive the Book Club News, describing the Main Selection and Alternate Selections, together with a dated reply card. If you want the Main Selection, do nothing and it will be sent to you automatically. If you prefer another selection, or no book at all, simply indicate your choice on the card, and return it by the date specified. You will have at least 10 days to decide. If, because of late mail delivery of the News, you should receive a book you do not want, we guarantee return postage.



**70230. PRINCIPLES OF SOFTWARE ENGINEERING AND DESIGN.** Marvin F. Zelkowitz et al. A practical guide which shows you how to handle everything from small programs all the way through the design of large, complex software systems. **\$24.50**

## Disassembling Object Code and Copyrighting Chairs

An argument for intelligibility of object code could be made on the basis of reverse-compiling. In principle, object code can be disassembled and converted into an intelligible form if proper parameters are known. For example, programs are available to convert (disassemble) object-code versions of programs for various microprocessors into assembly code. The assembly code is widely human-intelligible, at least in the software trade. It can be used to develop, and perhaps even computer-generate, high-level source code, which is generally recognized as both human-intelligible and copyrightable. Obviously, the same thing could be done for ROMs, although it is not clear that the end product of this process will always be the very same source program as that initially compiled to generate the object code.

The argument based on reverse-

compiling is that although object code may not be directly intelligible to most people, with the aid of a computer and program it can be put into an intelligible form. It is unclear, however, whether the fact that unintelligible symbol set A can be converted into intelligible symbol set B, by a transformation process, is the full equivalent of the copyright law's statutory concept that set A is a material object from which the underlying work (which may be equated here to intelligible symbol set B) can be "perceived or otherwise communicated." It is one thing to perceive a video tape of Casablanca with the aid of a TV set. It may be quite another thing to perceive a transformation of object code with the aid of a computer.

For one thing, the video tape of Casablanca is intended to be used primarily as an object of communica-

tion, while the ROM is intended to be used primarily as an object to operate a machine. This point was noted in several early piano-roll copyright decisions. Second, the transformation argument seems to prove too much and thus leads to unacceptable results. Buildings and chairs are clearly not writings. Thus, they are not copyrightable. Yet, either can be subjected to an optical-scanning process and, with the aid of a computer, be made to generate a set of intelligible and copyrightable blueprints. If a ROM is copyrightable simply because it can be made to generate source code or its equivalent, so too is a building or chair. The latter is clearly not the law, which suggests that something must be wrong with the argument. The argument based on the possibility of reverse-compilation is thus probably unsound.

sion that the potential of sapient perception and communication is essential to copyright protection. That is, the alleged copy of a program or other work must be intelligible to human perceivers and communicatees. It is not enough that it be machine-readable, for machines do not perceive works and one cannot communicate works to them except in a metaphorical sense. That is not the commonsense usage of "perceive" and "communicate." The alleged copy (object code), to be a "copy," thus would have to communicate something to humans in terms of idea or emotion, and they would have to be able to perceive it. Yet, even in its most communicable form (hard copy rather than ROM or disk), object code is a string of 0s and 1s unintelligible to most, even if not all, potential readers. In its ordinary physical form, such as a ROM, it is even less of a means of communication. (See the text box Disassembling Object Code and Copyrighting Chairs.)

**Further Amendments:** To be sure, we could try still another amendment of the copyright law to overcome the

problem. We could say, in so many words, that unauthorized electronic duplication of any information stored in a tape, disk, ROM, or other product capable of being encoded with program information (in the form of object code or otherwise) constitutes copyright infringement, irrespective of whether the information encoded is intelligible to persons. That is the cheap and dirty solution, usually favored heretofore, but it is unwise for several reasons.

First, if the trial court in the *Compuchess* case was right, there remains a constitutional problem. Object code may be protectable under a statute regulating interstate and foreign commerce, but not under one regulating "writings." The concept of "writings" in the Constitution may require substantial human-intelligibility of the alleged writing. It also may require that the alleged writing be intended as a medium of communication, rather than intended primarily to serve as a utilitarian object.

Second, copyright law is unsuitable and inappropriate for software. It is a worse vehicle for protecting software

than COBOL is for doing advanced mathematical calculations. Copyright law is the result of the evolution of a system to prevent book printers from copying books that were first published by other book printers. When copyright remedies and procedures are applied to other kinds of things, mass-produced products that any claimant wants to protect, those remedies and procedures do an inept job. Copyright now does an awkward and clumsy job of protecting lamp bases, junk jewelry, fabric designs, belt buckles, and toys. It will do no better for code in ROMs, disks, and tapes.

Even without the problems highlighted by the unloaded-ROM cases, copyright law is ill-suited to protecting software. The May 1981 issue of *BYTE* contains several surveys of the copyright law and other laws protecting software. They describe what follows in more detail and from a different perspective.

**Subject Matter of Copyright:** Copyright protects particular "expressions" (specific formulations or embodiments) of ideas, suiting copy-



# SPECIAL SALE!!

**MOST ECONOMICAL SOURCE TO BUY FLOPPY DRIVES — FROM ONE OF THE LARGEST DEALERS IN THE WORLD! NOW YOU CAN BUY TANDON, QUME, TEAC, SHUGART, MPI, SIEMENS, REMEX, YANKEE, APPLE, EPSON, DEC, CDC, CIPHER, NEC, TALLY, ALTOS, ATARI, DATAPRODUCTS, IBM AND MORE . . .**  
**... AT LOW COST!! IMMEDIATE SHIPPING!!**

**APPLE** DISK-DRIVE for APPLE II ..... **\$289.00**  
 100% Compatible (Runs DOS 3.2 and 3.3) ..... **INTRODUCTORY PRICE**  
 Z80 Card and 80 Column Card Available  
 5MB Winchester / Controller / Cables / Software ..... **\$1795.00**  
 10MB Winchester / Controller / Cables / Software ..... **\$1995.00**

**ATARI** **Computers/Video Games**  
 Models 410, 820, 822, 830, 850 available  
**ATARI SPECIAL**  
 DSDD Drive ..... **\$649.00**  
 Add on ..... **\$399.00**

800 Computer ..... **\$659.00**  
 400 Computer ..... **\$339.00**  
 810 Disk Drive ..... **\$449.00**  
 825 Printer ..... **\$629.00**  
 VIC20 ..... **\$249.00**

**IBM** **TANDON TM100-1 SSDD**  
 Disc Drive ..... **\$208.00**  
**TANDON TM100-2 DSDD**  
 Disk Drive ..... **\$274.00**  
 CS111-5 Disk Drive, TM100-1 Compatible . . . **\$199.00**  
 CS211-5 TM100-2 Compatible Drive . . . **\$259.00**

**IBM - MEMORIES**  
 64K ..... **\$189.00** 128K ..... **\$289.00**  
 256K ..... **\$499.00** 512K ..... **\$799.00**  
 5 and 10MB Winchesters available

## CABINETS / POWER SUPPLY

Dual 8" Disk Drive, Cabinet with Power Supply **\$249.00**  
 Cabinet/Power Supply for Single 8" Drive ..... **\$179.00**  
 Dual 5 1/4" Disk Drive, Cabinet with Power Supply **\$99.00**  
 Single 5 1/4" Disk Drive, Cabinet with Power Supply **\$69.00**  
 2 Single Side Double Density 8" Disk Drives,  
 Cabinet Power Supply ..... **\$895.00**

## PRINTERS / TERMINALS

**OKIDATA**  
 82A ..... **\$459.00** 83A ..... **\$730.00**  
 84AP ..... **\$989.00** 84AS ..... **\$1049.00**

**EPSON** ..... **MX-80** ..... **\$469.00**  
 MX-80 FT ..... **\$569.00** MX-100 ..... **\$769.00**

**BROTHER HR1** ..... **\$799.00**  
**SMITH CORONA TP1** ..... **\$599.00**

Call for C.ITOH, NEC, TELEVIDEO,  
**ADDS TERMINALS PRINTERS.**

**ALL FLOPPIES**  
**Repaired Quickly**  
**at LOW COST**

## DRIVES / COMPUTERS

**QUME DT-5 DSDD 5 1/4" Drive** ..... **\$285.00**  
**QUME DT-8 DSDD 8" Drive** ..... **\$479.00**  
**TANDON:** TM100-1 ..... **\$208.00**  
 TM100-2 ..... **\$274.00**  
 TM100-3 ..... **\$274.00**  
 TM100-4 ..... **\$399.00**  
 TM848-1 SSDD 8" Thin Line ..... **\$459.00**  
 TM848-2 DSDD 8" Thin Line ..... **\$549.00**  
 TM602-5 Winchester 5MB ..... **\$999.00**  
 TM603-10 Winchester 10MB ..... **\$1149.00**

**SIEMENS:** FDD 100-5 SSDD 5 1/4" ..... **\$189.00**  
 FDD 100-8 SSDD 8" ..... **\$349.00**  
 FDD 200-8 DSDD 8" ..... **\$449.00**

**SHUGART:** SA400 ..... **\$215.00**  
 SA450 ..... **\$279.00**  
 SA800 801 ..... **\$379.00**  
 SA850 851 ..... **\$535.00**

**TEAC:** FD50A ..... **\$199.00**  
 FD50B ..... **\$299.00**  
 FD50E ..... **\$299.00**  
 FD50F ..... **\$399.00**

**MITSUBISHI:** M2894-63 8" DSDD ..... **\$459.00**  
**NEC Computer PC 8000** ..... **Call**  
**XEROX Computer 820** ..... **Call**

FRANCHISE INQUIRIES WELCOMED

PRICES SUBJECT TO CHANGE WITHOUT NOTICE

## COMPU SHACK

Computers Video Games  
 A SUBSIDIARY OF POS Inc.  
 2630-H Walnut Ave.  
 Tustin, CA 92680

• 24 HOUR ORDERING SERVICE •

TOLL-FREE TELEPHONE NUMBERS

Outside California: (800) 854-8428

Inside California: (714) 730-7207 or (408) 973-1444

Telex: 18-3511 Answer Back CSMA

right more or less to protection of source code and documentation from outright duplication. But copyright law does not protect ideas, formulas, processes, and the like, as such. Accordingly, it cannot protect algorithms or the concepts on which programs are based.

**Infringement and Remedies:** Making and selling a "copy" of a copyrighted work is "copyright infringement," for which the standard remedies are:

- destruction of all offending copies
- award of damages to the copyright owner for the profits that would have been made on sales of copies diverted from the owner
- award of the infringer's profits on sales (if this is a separate, nonoverlapping item)
- an injunction against further copying

The copyright laws do *not* deal, however, with *use* of copyrighted

material. Moreover, the copyright laws do not contemplate intermediate remedies, such as mandatory reasonable-royalty licensing. Finally, they have no express or formal means for dealing with the severe problems of innocent purchasers who wish to resell the product.

Mere ownership and personal use of an infringing copy of a copyrighted work is not itself an infringement, but its resale is. Thus, even if copyright law protected ROMs, it would not prevent a customer from using an unlawfully copied ROM that had been purchased, or require the payment of damages for using the ROM. But it would prevent resale of the ROM or a microcomputer in which the ROM was an essential part. It is unclear whether the owner of the copyright on a ROM could get a court order for the destruction of the ROM when it is in the hands of a purchaser.

**Plagiarism:** The concept of non-duplicative copying or "plagiarism" is recognized in copyright cases involv-

ing books, plays, and music. But the concept in the software field is virtually undefined and prior copyright precedents are of almost no value. It is therefore unpredictable when a court will call one program a copy of another when the two are not identical. The inevitable importation of concepts developed for books and plays must add a very substantial random element to the decision process.

### Patent Law

Patent law is in many ways theoretically or conceptually more suited than copyright to software. But it too has severe problems. First, it is clear that algorithms and concepts of programs, as well as pure programs considered in isolation, are unpatentable under the present patent law. Programs in the matrix or setting of a machine system, however, may be patentable. For example, a machine system for molding and curing rubber is patentable even though the central elements of the system are a ROM-stored program and microprocessor designed to cooperate with other elements to cause the mold to open after an optimum heat history. Data-processing applications may run into more problems.

A patent is granted only for new and unobvious subject matter. Improvements in programs seldom meet this difficult test. Moreover, 70 percent of all issued patents that reach appellate courts are held invalid. A new kind of ROM as such could be patented as a new machine, but an old ROM with a new program encoded in it could not. It would be considered like trying to patent an old player piano with a new piano roll in it.

The remedies of the patent system are generally similar to those of copyright, although more suited conceptually to software. Thus, using a patented product or process without authorization is patent infringement, unlike unauthorized use of a copyrighted work. Moreover, the concept of patent infringement is much more definite than copyright infringement because a patent has "claims" specifi-

# I-Queue™

...the intelligent buffer that frees your IBM Personal Computer from the time-consuming printing function.

I-Queue accepts data at processor speed (over 4000 characters per second) and sends it to the printer\* at whatever speed the printer can accept.

I-Queue can store 16K of RAM, which is approximately 7 pages of average printout (optionally expandable to 65K for storage of 28 average pages). Standard features include complete pagination and formatting capabilities, a reprint buffer, a clock/calendar and many other design enhancements usually found only in sophisticated word processors.

Available direct or from participating PC dealers. Distributor and dealer inquiries invited. For new brochure, write, or call our 800 number.

\*Fully compatible with IBM printer and all Centronics interface printers.

IBM Personal Computer is a trademark of IBM.

AVAILABLE FROM STOCK -  
WITH CLOCK/CALENDAR &  
COMPLETE DEMO PROGRAMS: \$495  
65K MEMORY EXPANSION OPTION: \$175

**PERIPHERX Inc.**  
149 Palmer Road  
Southbury, CT 06488  
800-221-0732 In NY: (212) 961-2103



## Introducing THE Pineapple™

### 48K Color Computer Kit

Easy to assembly! All components are clearly silk screened on the circuit board. Kit includes predrilled double sided PC Board, all integrated circuits, sockets, professional high-impact plastic casing, keyboards, connectors and switching power supply.

- Features • Numeric key pad • Game paddle jacks on both sides •
- Speaker volume control on the back • Expansion slots •

**\$645<sup>00</sup>** per kit

No C.O.D. orders

Dealer Inquiries Invited.

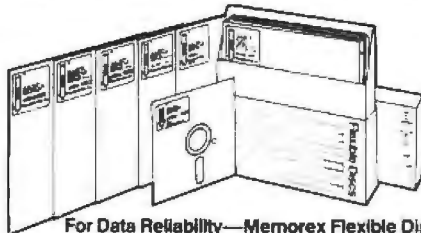

For Data Reliability—Memorex Flexible Discs

### 5 1/4" Flexible Disc Sale

Why buy other brands when you can buy MEMOREX disc for much less and backed by 1 year factory warranty.

#### \*PRICE BREAK-THRU ON APPLE® DRIVE!

100% APPLE Compatible  
5 1/4" Floppy Disc Drive



**\$295.00** Each  
**\$375.00** Each  
(with controller)

PART #	DESCRIPTION	PRICE
3481	5 1/4"SSDD Soft Sector w/Hub Ring	10 for \$250 ea.
3483	5 1/4"SSDD 10 Hard Sector w/Hub Ring	Call for our low prices on larger quantities.
3485	5 1/4"SSDD16 Hard Sector w/Hub Ring	

#### \*16K RAM BOARD KIT

Upgrade your Apple computer to 64K with this easy-to-build kit. Includes 8 ea. 4116 memory chips and all necessary I.C.s and components. Gold plated fingers.  
**only \$59.95 per kit.**

VISA

**PHONE ORDERS ONLY 1-800-672-8758 CALL TOLL FREE**



#### MICROPROCESSOR COMPONENTS

Z80.....	8.75	Z80A-DMA..	28.50	2708.....	5.95
Z80A.....	9.25	2102.....	1.50	2716.....	9.60
8080A.....	5.50	21L02.....	1.50	2516.....	11.95
Z80-PIO.....	7.50	2114.....	2.95	2732.....	15.95
Z80A-PIO.....	8.50	2114L.....	2.95	2532.....	16.95
Z80A-SIO.....	29.50	4116.....	3.00	2764.....	49.95
Z80A-CTC.....	8.50	1702A.....	4.95		

#### SANYO MONITORS

MODEL NO.	DESCRIPTION	LIST	SALE
VM4509	9" B&W, 10 MHz	\$190.00	\$169.00
DM5109	9" Green 10 MHz	\$200.00	\$180.00
DM 8012	12" B&W, 18 MHz	\$250.00	\$225.00
DM 8112	12" Green, 18 MHz	\$260.00	\$235.00
DMC 6013	13" Color	\$470.00	\$425.00
DMC 6113	13" RGB Color	\$995.00	\$895.00

#### IC SOCKETS

LP	WW	LP	WW
8-pin	5/1.75	22-pin	5/1.62
14-pin	5/1.00	24-pin	5/1.80
16-pin	5/1.20	28-pin	5/2.10
18-pin	5/1.35	40-pin	5/3.02
		20-pin	5/1.52
			5/4.55

#### NEW! 16K RAM CARD KIT FOR YOUR APPLE® COMPUTER \*

Kit includes: High Quality P.C. Board • 8 ea. 4116 (200ns) • All the IC's & parts • 16-pin Dip wire • Easy to assemble. You can do it in less than 30 minutes!

**\$59.95** per kit  
(Limited Quantity)

\* Apple is a registered trademark of APPLE COMPUTERS, INC.

SHIPPING AND HANDLING CHARGES  
Under \$50.00 Purchase: Over \$50.00 Purchase

Inside California	10%	5%
Outside Calif (Incl. Mexico & Canada)	15%	10%
Overseas	25%	20%

Minimum Order \$10.00 / Calif. Residents add 6.5% Sales Tax. Phone Orders Accepted on VISA or MC ONLY. NO C.O.D.'s. Prices subject to change without notice.

Circle 198 on inquiry card.

**STORE HOURS**  
MON-FRI — 10-7  
SAT — 10-6

# CP/M® Users: Access IBM with ReformatTer™

ReformatTer conversion software lets you read and write IBM 3740 diskettes\* on your CP/M or MP/M system.

ReformatTer is ideal for CP/M users who want

- Access to large system data bases
- Distributed data processing
- Offline program development
- Database conversion

With ReformatTer, you have the ability to

- Bidirectionally transfer complete files between CP/M and IBM
- Automatically handle ASCII/EBCDIC code conversion
- Display and alter IBM 3740 directory and data

Enjoy the same advantages of mainframe access that other ReformatTer users have. Customers like Upjohn, M&M/Mars, The United Nations, Arthur Young & Co., Sandia Labs, FMC Corp., and Stanford University all use ReformatTer. So can you.

Other versions of ReformatTer conversion software include

CP/M ↔ DEC (RT 11)

TRSDOS Mod. II ↔ CP/M

TRSDOS Mod. II ↔ DEC (RT 11)

Order ReformatTer today for only \$249.

\*IBM 3740 basic data exchange format. ReformatTer requires one 8" floppy drive.

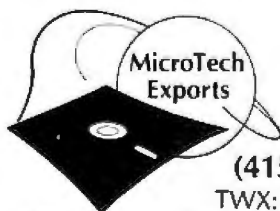

(415) 324-9114

TWX: 910-370-7457

467 Hamilton Av., Suite 2, Palo Alto, CA 94301

CP/M is a reg. trademark of Digital Research

Please send complete information on the following versions of ReformatTer:

Please send ReformatTer CP/M ↔ IBM. My check for \$249 (plus \$5 shipping, Cal. Res. add 6½% sales tax). Charge to my  VISA  MasterCard.

# \_\_\_\_\_ exp. date \_\_\_\_\_

Signature \_\_\_\_\_

Name \_\_\_\_\_

Company \_\_\_\_\_

Street \_\_\_\_\_

City \_\_\_\_\_

State \_\_\_\_\_ Zip \_\_\_\_\_

Mail to MicroTech Exports, Inc.  
467 Hamilton Ave., Palo Alto, CA 94301

cally defining its coverage. For example, if someone could legitimately claim inventorship of the idea of subroutines and if the patent laws would somehow (under an amended law) reach such things, it would in principle be possible to write a patent and patent claim covering GOSUB. Of course, that is not how the copyright laws operate, and one could not, even in principle, copyright GOSUB.

### Trade Secret and Contract Law

Trade secrets, and contractual arrangements tied in with reliance on trade secrets, are the most widely used form of software protection in the United States at this time. (In large part that reflects the inadequacy of present copyright law and patent law.) Since this body of law is nonfederal, unlike patents and copyrights, it varies widely from state to state. Ideas can be protected under contract law. Therefore, difficulty with algorithms and program concepts does not apply here. By the same token, parties can contractually bind *themselves* (but not others) not to unload ROMs or other forms of object code. The only limits to contracts are set by public policy and by the limitations of drafting ability.

The real problem, however, is with third parties. A contract or duty of secrecy between Tom and Dick does not bind Harry. Unless Harry knowingly induces Dick to breach a secrecy agreement with Tom, Tom probably has no remedy against Harry. Thus, Harry may buy or borrow Dick's machine with Tom's ROM, or lease it from Dick, or foreclose on it, and then unload the ROM with impunity. Even if Dick lends, leases, or sells to Harry in violation of Dick's contract with Tom not to do so, Tom has no right against the unknowing (and therefore innocent) Harry. There may be ways to minimize these risks, by restrictive agreements or leases, but they are impractical and/or impossible with such mass-marketed products as those involved in the three ROM cases discussed above.

The secrecy of a trade secret is fragile. Contract rights are ineffective against third parties. Restrictive

agreements may also fail if the trade secret becomes public. In combination, trade secrets and contracts probably protect software proprietors better than present copyright law does, but they probably give less protection than an amended copyright or patent law could furnish. None of these different systems, however, is capable of protecting software effectively because of their main commitments in other directions.

The problem with using these several forms of law to protect software is that it takes too much creativity and energy to persuade the courts to apply them sensibly to software. These other kinds of law have evolved acceptable solutions for the problems with which they ordinarily deal. It makes good sense not to protect mere ideas under copyright and patent law. It makes good sense to protect plans and blueprints, but not buildings or machines, under copyright law. It makes good sense not to bind third parties to the contracts of others. It makes good sense to protect trade secrets only when they are not widely known. But none of this deals properly with the interests at stake in software and the kind of fact patterns characteristic of software ownership and use controversies.

### Dealing with the Special Problems of Software

A proper system for protecting software from misappropriation would have to:

- accommodate the conflicting interests of the various groups concerned with the use and protection of software
- devise remedies tailored to deal with the different ways in which software can be appropriated
- be structured for ease of access to the system and ease of administration
- generally encourage development of new software without discouraging the use of software or the growth of the industry

The second part of this article, which will appear in next month's issue, will address those issues. ■

# TIM<sup>®</sup> III

## The Non-Programming Approach to Data Base Management

### Data Base Management

Data management packages were created to save time and money in the development of software solutions to information problems. Many have been designed to accomplish just that, although most have only the programmer in mind. Sure they would save time in the long run, but what of the initial investment in time and effort required to learn the new language? What about the non-programmers in the world who would like an easy yet powerful applications generator? The solution is one of the most highly acclaimed software packages of our time, T.I.M. III.

### What is T.I.M.?

T.I.M. is **Total Information Management**. Programmers love it due to its original solutions to classic data management problems. Non-programmers adore it since they can use it to achieve the same results as with other more complicated programming-like packages.

### What Makes T.I.M. So Simple to Use?

We at Innovative Software, Inc. designed T.I.M. from day one with the end user in mind. Maybe he is a programmer who doesn't have time to learn a new language. Or perhaps a neophyte who fears coding pads and lines numbered by tens. We felt that a data

management package should be able to be used by anyone from a systems analyst to a secretary. That's why T.I.M. takes a full *menu-driven* approach, uses multiple *HELP* screens, and has a manual that sets a new standard in documentation.

### Features of T.I.M.

T.I.M. has all of the features one has come to expect from a data management package, as well as many new ones. For example, a *word processing* interface that allows you to merge information from a T.I.M. file with letters or other documents created by a word processor. Now you can automatically send personalized letters to hundreds or thousands—quickly and easily. T.I.M.'s *Select* command enables you to pull specific information from a file. For example, "All customers who live in a certain ZIP code, whose last name begins with the letter A to L, whose balance due is less than \$50.00." A sophisticated *report generator* and even a *list generator* are also included.

How powerful is T.I.M.? With a maximum record size of 2400 characters and the ability to keep up to forty fields sorted properly at all times, T.I.M. is powerful enough to handle just about any application. T.I.M. can handle over 32,000 records per file, and two files can be linked together for reports if your application requires a many-to-one relationship. T.I.M. also includes all of the same editing commands as your word processor, thus making data entry and

editing a snap. You can also pull selected records from one file to place them into another. Files may be restructured to add or subtract fields and/or change field lengths or types. T.I.M. even has its own utility for backing up hard disks onto floppies.

### The Manual

Many people believe that the manual is just as important as the software itself, a view that we at Innovative Software, Inc. tend to share. The manual for T.I.M. is divided into two sections, the Reference section and the Primer. The Reference section describes all of T.I.M.'s commands and subcommands. This is done in English, not in technical terms or in our own language. Even if you have never seen a computer before in your life, you'll be able to read and understand our manual immediately. The second section is a primer which goes through several examples for you, again in plain English. These true-to-life examples take the beginner by the hand and instruct him what to do and when. You will be able to see for yourself that T.I.M.'s only limitation is the imagination of the user.

### Where to Find T.I.M.

T.I.M. is available from many fine computer dealers across the country. Or you may purchase from us direct by calling 913/383-1089. Either way you will have the finest data management program available.

Available for CPM,\* and IBM PC DOS.\*\*

CPM version—\$695. IBM PC version—\$495.

TIM is a Trademark of Innovative Software, Inc.  
\*CPM and MP/M are Trademarks of Digital Research  
\*\*Trademarks of IBM



Innovative Software, Inc.  
9300 W. 110th Street, Suite 380  
Overland Park, Kansas 66210 USA  
913/383-1089

# A Comparison of Five Compilers for Apple BASIC

*Speed isn't the only criterion to consider when choosing a compiler.*

---

Joseph H. Taylor and Jeffrey S. Taylor  
272 Hartley Ave.  
Princeton, NJ 08540

---

The BASIC language, in the form commonly available on personal computers, has been a great boon to the spreading popularity of these machines. BASIC is easy to learn, usable in a wide range of applications, efficient in memory usage, and inexpensive to incorporate into hardware. The enormous success of computers such as the Apple II, the Commodore PET, and the Radio Shack TRS-80 is, we think, largely a result of their friendly implementation of BASIC—a high-level language stored in ROM (read-only memory).

However, the BASICs used in nearly all personal computers suffer from one serious drawback: they are slow. This is largely a result of BASIC being present in the form of an interpreter, a machine-language program that supervises the execution of the user's BASIC program. The supervision is

accomplished by sequentially scanning the text lines that make up the program at the time the BASIC program is running (that is, at execution time). Each line is decoded to determine the numerical or logical operations desired, and the interpreter calls

lines written by the programmer) is stored in the computer's memory at execution time. The program can run much faster than it could under the control of an interpreter because the scanning and decoding is done only once, at compilation time.

In this article, we review five different compilers designed for use on the Apple II computer, all of which were first marketed during the past year. One of them, the Integer BASIC Compiler by Galfo Systems, works only with programs written in Apple Integer BASIC. Although this language subset is not suitable for some applications—especially those involving extensive calculations or “number crunching”—it is eminently useful in others and produces extremely fast and compact code when used with the Galfo compiler. In some time-critical applications, this speed advantage (typically 10 times faster than interpreted Integer BASIC and 15 or more times faster than Applesoft) might be very important.

The other four compilers reviewed are Applesoft Compiler (Hayden Book Company), TASC (which stands for The Applesoft Compiler,

---

**Our primary yardstick for comparing the five compilers was execution speed, and we used the speed of the Applesoft Interpreter as the standard reference point.**

---

appropriate subroutines (within its own program code) to carry out the indicated operations.

A much more efficient scheme, used in nearly all serious computer applications, is to use a compiler to translate the program's logical structure into code directly executable by the computer hardware. This object code (rather than the source code

---

#### About the Authors

*Joseph H. Taylor is a professor of physics at Princeton University and uses computers (from microcomputers to mainframes) in his research work on pulsars and other phenomena in astrophysics. His son Jeffrey is a student at Princeton High School and carried out most of the tests of the compilers described in this article.*

**NEW**

# 512KB WITH RS232-C PORT IBM PERSONAL COMPUTER MEMORY!

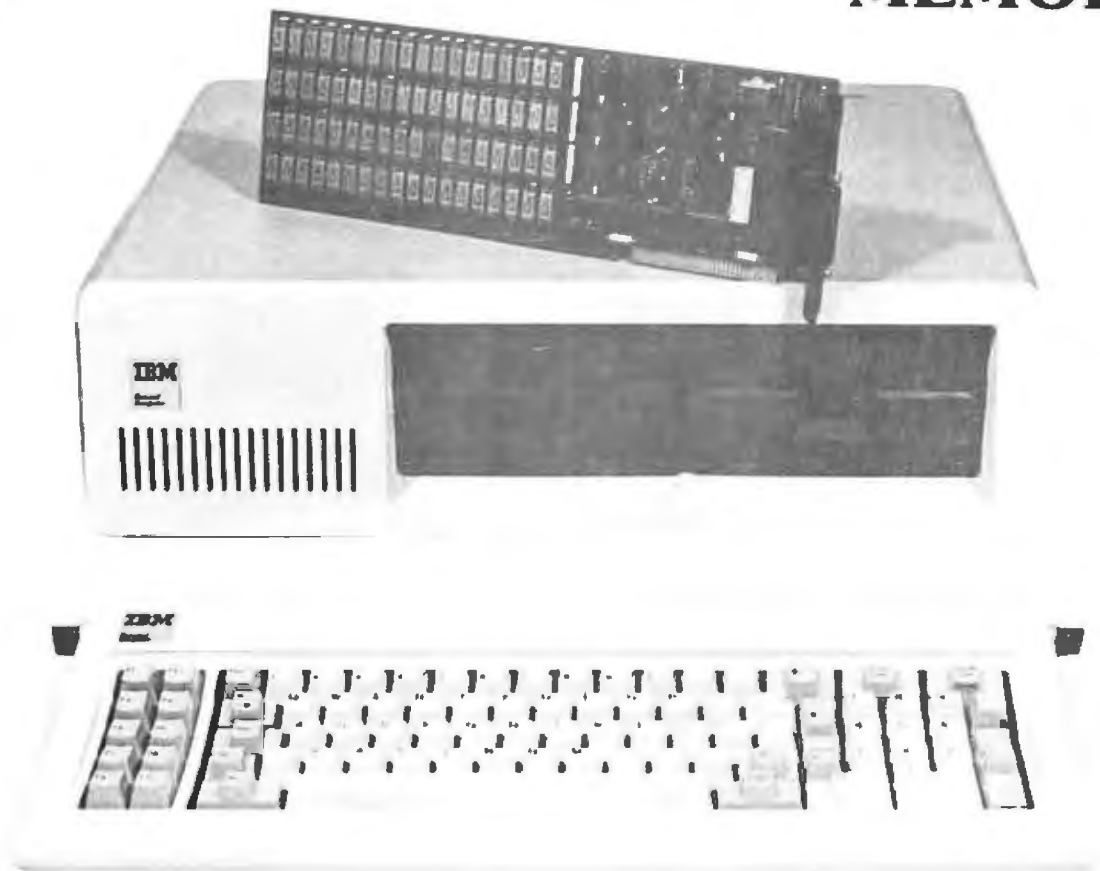

## SINGLE BOARD 512KB WITH RS232-C IBM PERSONAL COMPUTER MEMORY

Designed Specifically for IBM's PERSONAL COMPUTER is Chrislin Industries newest CI-PCM+ and CI-PCM Memory Modules.

- Pin-to-pin compatibility.
- Full one year parts and labor warranty.
- On-board parity with interrupt on parity error.
- Off the shelf deliveries.
- Addressable as a contiguous block in 64KB increments thru 1 megabyte.

CI-PCM without RS232-C	CI-PCM+ with RS232-C
256K x 9 ..... \$475.00	512K x 9 ..... \$895.00

**DON'T ASK WHY WE CHARGE SO LITTLE, ASK WHY THEY CHARGE SO MUCH.**



### **Chrislin Industries, Inc.**

31352 Via Colinas • Westlake Village, CA 91362 • 213-991-2254  
TWX 910-494-1253 (CHRISLIN WKVG)

## At a Glance

Name	Applesoft Compiler	TASC	Expediter II	Speed Star	
<b>Type</b>	Compiles Integer BASIC. These products compile programs written in Applesoft BASIC.				
<b>Manufacturer</b>	Galfo Systems 6252 Camino Verde San Jose, CA 95119	Hayden Book Co. 50 Essex St. Rochelle Park, NJ 07662	Microsoft 400 108th Ave. NE Bellevue, WA 98004	On-Line Systems 36575 Mudge Ranch Rd. Coarsegold, CA 93614	Southwestern Data Systems 10761, Suite E, Woodside Ave. Santee, CA 92071
<b>Price</b>	\$150	\$175	\$160	\$100	\$135
<b>Format</b>	Two 5¼-inch floppy disks (16 sector)	5¼-inch floppy disk (13- and 16-sector available)	5¼-inch floppy disk (13-sector, can be copied to 16-sector)	5¼-inch floppy disk (13- and 16-sector copies provided)	5¼-inch floppy disk (16-sector); hardware key plugs into paddle port
<b>Language</b>	6502 machine language	6502 machine language	Compiled Applesoft (source not provided)	6502 machine language	6502 machine language
<b>Computer</b>	Apple II or II Plus, with 32K or 48K bytes of memory and one disk drive. Integer BASIC required in ROM or in the Language Card at compile time.				
<b>Documentation</b>	30 pages; soft binder	27 pages; three-ring binder	97 pages; two-ring padded binder	16 pages; paper cover	54 pages; three-ring padded binder
<b>Warranty</b>	Money-back guarantee	Damaged disk replaced for \$20 fee	If defective, will replace within 12 months of purchase	Free replacement, if necessary, within 90 days	Unconditional replacement or refund within 30 days
<b>Audience</b>	Anyone writing programs in BASIC for the Apple II computer and needing improved execution speed or security of source code				

from Microsoft), Expediter II (On-Line Systems), and Speed Star (Southwestern Data Systems). All of them compile programs written in Applesoft, a widely used BASIC dialect with good string-handling and graphics capabilities and full floating-point support. The object code produced by these compilers generally runs 2 to 10 times faster than the respective programs being executed under the Applesoft interpreter.

### The Compilers and the Tests

Each of the compiler systems is furnished in machine-language form on one or two 5¼-inch floppy disks. The Applesoft compilers are usable on any Apple II or II Plus computer with 48K bytes of RAM (random-access read/write memory) and one or more disk drives; the Applesoft interpreter must also be present, either in ROM, the Language Card, or another 16K-byte RAM card. The Integer

BASIC Compiler requires 32K bytes of RAM and at least one disk drive, and the Integer BASIC interpreter must be present in ROM or in the Language Card at compilation time. The interpreter is not required at execution time, so compiled programs can be run on machines without Integer BASIC.

Our primary yardstick for comparing the five compilers was execution speed, and we used the speed of the Applesoft interpreter as the standard reference point. We wrote (or adapted from the literature) eight benchmark programs, chosen to evaluate different features of the BASIC language. Brief descriptions of each of the eight test programs are given in table 1, and full listings are presented in listings 1 through 8. Some trivial changes in syntax were required, of course, in copying the programs from Applesoft into Integer BASIC, but otherwise the identical programs

were run under each interpreter and compiler. The first five programs test integer arithmetic, loops, magnitude comparisons, and array shuffling. The last three programs assess features not implemented in Integer BASIC: The ALPHA program tests string-array handling and string comparisons, and MATINV and FFT test multidimensional array manipulation and some relatively complicated floating-point "number crunching." Our experience shows that the exact choice of benchmark programs is not very important. The better compilers were superior (or at least comparable to the others) for all of the programs tested.

Other criteria besides execution speed are of interest to some users because of particular needs. One of the most important of these is the size of the resulting object-code program. In most cases, the compiled code is larger than the BASIC source pro-



# AMX

## Real-Time Multitasking Executive

for  
8080, Z80  
and 6809

### Gives your application a head start

AMX can save you time and money. You can capitalize on our years of multitasking experience. Start your application using a software executive proven with three years of fault-free operation.

Professional software designers use AMX as the starting point for their product and system designs. AMX shields them from the difficulties of managing the micro, freeing them to concentrate on their application.

#### SIMPLE OPERATION

Complex control programs are divided into a number of separate, more manageable programs, called *tasks*, each designed to do one job. Tasks are written and tested separately and then combined to form a reliable, finished system.

AMX supervises the orderly execution of these tasks, assuring that the most important jobs always get done first. Tasks appear to be executing simultaneously. It's almost like having a separate CPU for each task!

#### HARDWARE INDEPENDENCE

AMX does not require a particular hardware configuration. *You* control

your environment. *You* pick the I/O method. *You* decide the preferred interrupt service technique for your system. AMX will support your choice.

AMX is fast, compact, and ROMable. Even though the AMX nucleus is less than 1400 bytes in size, it features multiple task priorities, intertask message passing with priority queuing, external event synchronization, and interval timing.

Interface modules are available to allow AMX to be used with C, PASCAL, PL/M, FORTRAN and assembler.

Access to CP/M\* disk files in real time is possible using the AMX I/O Supervisor.

#### COMPLETE DOCUMENTATION

AMX can be judged by the quality of our documentation.

We deliver AMX source on diskette to permit AMX to be moved to the software development system of your choice. Our liberal license agreement permits binary (object) distribution without royalties.

#### HOW TO ORDER

A specification sheet and price list are available, free. Your check or money order for \$75 will purchase the AMX Reference Manual for immediate evaluation (specify 8080, 8085, Z80 or 6809 processor). Add \$25 for postage and handling outside USA and Canada. The standard AMX Multitasking Executive package, including source code, is \$800.

AMX is the choice of professionals the world over. Make it yours, today.

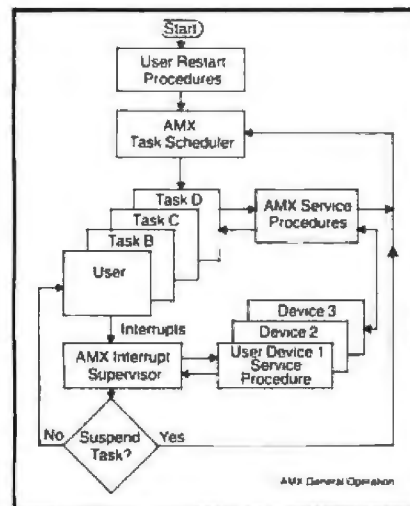

CP/M is a trademark of Digital Research Corp  
Z80 is a trademark of Zilog Corp



## KADAK Products Ltd.



206-1847 W. Broadway Ave., Vancouver, B.C., Canada V6J 1Y5 Phone: (604) 734-2796 Telex: 04-55670

gram and, therefore, requires more disk space and memory. In addition, each compiler system requires a run-time library of support routines to be present in RAM at execution time. The run-time libraries range from approximately 2K to 4K bytes in size. For very long programs these code expansion considerations may be of paramount importance.

Each of the compilers provides a number of options from which the user can choose through a question-and-answer dialogue or "active remark" (REM) statements included in the source code itself. (These active REM statements will be ignored, of course, by the BASIC interpreter; they are used to provide information to the compiler only.) Most of the options serve to control the addresses of the object code and run-time library at execution time—for example, to avoid interference with Apple's high-resolution graphics pages or to allow several compiled programs to share some common variables and a single copy of the run-time library. As another option, TASC permits an active REM to declare any or all of the program's numeric variables to be integers, without having to append the otherwise obligatory percent signs (%) throughout the source program. Because TASC (like the Hayden Applesoft Compiler, but unlike Expediter II, Speed Star, and the BASIC interpreter) evaluates integer expressions using efficient 16-bit integer arithmetic, an integer declaration for all quantities used as integers can speed up program execution considerably.

### Ranking by Execution Speed

The results of our execution speed comparisons are presented in figure 1. In all cases, the relative speed for a given compiler was obtained by dividing the Applesoft Interpreter execution time (given in table 1) by the time required to run the same program after compilation. As figure 1 indicates, Galfo Systems' Integer BASIC Compiler was the clear winner for the five programs that it was able to compile. Its generated code ran 1.5 to 8 times faster than that of any of the other compilers, 8 to 12

Program Name	Applesoft Interpreter Execution Time (seconds)	Brief Description of Program
PRIME1	16.9	Generates all prime numbers less than 1000, using the "Sieve of Eratosthenes" algorithm (see "A High-Level Language Benchmark" by Jim Gilbreath, September 1981 BYTE, page 180).
PRIME2	28.2	Generates all prime numbers less than 1000, using the algorithm given by Charles Porter (see "Some More on Performance Evaluation" by Carl Helmers, July 1980 BYTE, page 216).
SIGAV	44.2	Signal-averager program, as might be used in a laboratory data-acquisition system. Uses integer arithmetic.
KBAUD7	46.3	BASIC benchmark used by Rugg and Feldman (Kilobaud, October 1977, page 20).
SORT	24.8	Sorts a list of numbers into ascending order.
ALPHA	15.4	Sorts a list of words into alphabetical order.
MATINV	40.2	Inverts a 10 by 10 matrix.
FFT	22.6	Computes the discrete Fourier transform of a 64-point complex array.

Table 1: Programs used in execution time comparisons. The times given are derived using interpreted BASIC.

Listing 1: PRIME1 program computes all prime numbers from 1 to 1000.

```

100 REM *****
110 REM * PRIME1 *
120 REM *****
130 HOME :MAX = 1000
140 SIZE = INT ((MAX - 1) / 2)
150 B$ = CHR$(7)
160 DIM FL$(500)
170 INPUT "READY ? ";A$
180 PRINT "START" + B$
190 COUNT = 0
200 FOR I = 0 TO SIZE
210 FL$(I) = 1
220 NEXT I
230 FOR I = 0 TO SIZE
240 IF FL$(I) = 0 THEN 330
250 PRIME = I + I + 3
260 K = I + PRIME
270 IF K > SIZE THEN 310
280 FL$(K) = 0
290 K = K + PRIME
300 GOTO 270
310 COUNT = COUNT + 1
320 REM "PRINT PRIME" HERE IF DESIRED
330 NEXT I
340 PRINT B$ + "STOP"
350 PRINT COUNT;" PRIMES"
360 END

```

# Are you looking for a DATA BASE?



THE **BEST** DATA BASE SYSTEM

# GBS

IS READY TO DO **YOUR** JOB

GBS™	\$300
QUICK GEN™	\$125
REPORT GEN™	\$150
MENU GEN™	\$ 75
CONVERT	\$ 60

## IF YOU AREN'T A PROGRAMMER . . .

. . . our program generator, **QUICK GEN**, is ready to help you. With **QUICK GEN** almost anyone — even those unsophisticated about computers — may generate powerful business programs. In a short time, you can create a program and a data file that allows an operator, using menu choices, to selectively . . .

**review records    add records**  
**edit records        delete records**  
**update records    print out records**

**QUICK GEN** guides you through the following easy steps. When you finish, you will have created a **GBS** program and a data file.

1. Create a screen of labels and headings using a full-screen editor
2. Define data fields, including type and format
3. Position data fields on the display by moving the cursor
4. Write equations that perform calculations on the displayed data

Also of help to the non-programmer is our report generator **REPORT GEN**. With it you may create programs that can produce a wide range of customized reports. Check out these features of **REPORT GEN**:

**Complete file printout**  
**Summary printout to your specifications**  
**One line per record, or Multiple lines per record**  
**Print from up to three related files**  
**Compute subtotals and totals**

Finally, there is **MENU GEN**. It ties all of your programs together and permits an operator to work exclusively from menus. **QUICK GEN**, **REPORT GEN**, and **MENU GEN** all require **GBS** to operate.

## IF YOU ARE A PROGRAMMER . . .

. . . you need **GBS**. It is a powerful, fully programmable, relational database management system. You can access 3 different files simultaneously, and work with as many files as you need within a single program. Use one-to-one, one-to-many, or many-to-one relationships. **GBS** allows data files to span four disk drives. Up to ten indexes may be used simultaneously with each data file, and they are automatically updated when records are added or indexed fields are changed.

**GBS** uses disk space well by compressing screens and program tables, and by requiring only 24K of disk space to index a data file of 5000 records. When you run applications, **GBS** need not be available on disk, thus freeing often valuable disk space and avoiding tedious overlays of program code.

When you program **GBS**, all the tools are immediately available. You may program and test without requiring an outside editor, assembler, or compiler. Thus, changes may be made and tested in seconds.

You program **GBS** by making table entries using a full screen editor. The tabular structure allows **GBS** to execute your applications and those created using the **GENerator** programs extremely rapidly.

You may construct screens with a full screen editor. Later, your programs will display these screens with a single instruction. You may use subroutines to shorten and organize your programs. The fields in a record may be referenced like an array. And for those learning to use **GBS**, there are valuable **HELPS** available on call.

## START USING GBS NOW.

**GBS** is up and running on most popular **CP/M\*** based computers, like those made by Apple, Tandy, Xerox, Sharp, NEC, Osborne, Televideo, Hewlett Packard, Vector, Toshiba, Altos, and more.

If you are now using an older, slower data base management system, you can move up to the power of **GBS** and adapt your current data files with the help of our optional utility **CONVERT**.

You can order **GBS** with confidence because **we guarantee it!** If **GBS** isn't all we say it is, and more, simply return it within 30 days for a full refund. This offer is for a limited time only, so please act immediately. Discuss these terms with your local computer store manager — he may be a participating **GBS** dealer.

### Call Today

Contact us today for additional information or to take advantage of our special 30-day Money Back Guarantee.



**GBS** — it's the best business decision you can make, for today and for the future.

**QUALITY SOFTWARE**

6660 Reseda Blvd., Suite 107  
Reseda, CA 91335 (213) 344-6599

\*CP/M is a registered trademark of Digital Research

**Listing 2:** PRIME2 also computes all prime numbers from 1 to 1000.

```

100 REM *****
110 REM * PRIME2 *
120 REM *****
130 HOME :L = 1000
140 B$ = CHR$(7)
150 INPUT "READY ? ";A$
160 PRINT "START" + B$
170 DIM A%(1001)
180 FOR I = 2 TO L
185 A%(I) = 1
190 NEXT I
200 X = 2
210 IF 2 * X > L GOTO 230
220 FOR I = 2 * X TO L STEP X
222 A%(I) = 0
224 NEXT I
230 X = X + 1
240 IF X = L THEN 270
250 IF A%(X) = 0 THEN 230
260 GOTO 210
270 PRINT B$ + "STOP"
280 FOR I = 2 TO L
290 IF A%(I) < > 0 THEN PRINT I
300 NEXT I
310 END

```

**Listing 3:** SIGAV generates a simulated periodic waveform and, using integer arithmetic, computes the average shape of the wave.

```

100 REM *****
110 REM * SIGAV *
120 REM *****
130 HOME
140 PRINT "GENERATING DATA"
150 DIM D(4096),P(20)
160 FOR I = 1 TO 4096
170 D(I) = 0: NEXT I
180 FOR I = 3 TO 4096 STEP 7
190 D(I) = D(I) + 1
200 NEXT I
210 B$ = CHR$(7)
220 INPUT "READY ? ";A$
230 PRINT "START" + B$
240 GOSUB 1000
250 PRINT B$ + "END"
260 FOR I = 1 TO 7
270 PRINT P(I)
280 NEXT I
290 END
1000 REM *****
1002 REM * SIGNAL AVERAGER *
1004 REM *****
1010 FOR I = 1 TO 7
1020 P(I) = 0
1030 FOR J = 0 TO 4089 STEP 7
1040 P(I) = P(I) + D(I + J)
1045 NEXT J
1050 NEXT I
1060 RETURN

```

**Listing 4:** KBAUD7 tests BASIC operations including integer arithmetic, subroutine call, and magnitude comparison.

```

100 REM *****
110 REM * KBAUD7 *
120 REM *****
130 HOME
140 B$ = CHR$(7)
150 INPUT "READY ? ";A$
160 PRINT "START" + B$
170 K = 0
180 DIM M(5)
190 K = K + 1
200 A = K / 2 * 3 + 4 - 5
210 GOSUB 280
220 FOR L = 1 TO 5
230 M(L) = A
240 NEXT L
250 IF K < 1000 THEN 190
260 PRINT B$ + "STOP"
270 END
280 RETURN

```

**Listing 5:** SORT performs a sort of numbers into ascending order.

```

100 REM *****
110 REM * SORT *
120 REM *****
130 HOME
140 INPUT "READY ? ";A$
150 B$ = CHR$(7)
160 PRINT "START" + B$
170 DIM A(41)
180 X = 17
190 FOR I = 1 TO 40
200 X = X * 37
210 X = X - 100 * INT(X / 100)
220 A(I) = X
230 NEXT I
240 N = I
250 S = 0
260 FOR I = 2 TO N
270 IF A(I - 1) < = A(I) THEN 320
280 Z = A(I - 1)
290 A(I - 1) = A(I)
300 A(I) = Z
310 S = 1
320 NEXT I
330 IF S = 1 THEN 250
340 PRINT B$ + "STOP"
350 K = 0
360 FOR I = 1 TO N
370 PRINT TAB(12 * K + 1);A(I);
380 K = K + 1: IF K < 3 GOTO 410
390 K = 0
400 PRINT
410 NEXT I
420 END

```

# END THE PAPER CHASE.

Now you can computerize your business forms and input screens without all that tedious, time consuming programming.

With ZIP,<sup>™</sup> it's going to seem almost too easy.

## Just "paint" the screen.

To prepare an input screen or output form, just move the cursor around the screen and type in text, prompts and data field names exactly where you want them. Use "@" to print or display values, use ";" for input fields.

When the screen looks like the format you want, type "/S" and what you see is what you'll get. In seconds, ZIP writes all the program code to recreate the format on the screen or on paper.

And you can use the ZIP code immediately just by adding a single line to your main program: GOSUB xxxxx in BASIC, DO Formname in dBASE II.

## ZIP is quick and friendly.

ZIP runs on virtually every 8-bit micro known to man, and your terminal continues to work the way it did (tab, arrows, etc.), so you don't have to learn or unlearn anything about your equipment.

Commands are typed (no control codes), so you or your secretary can breeze through input screens and output forms up to 88 lines long and have ZIP whip out the BASIC or dBASE II code.

The ZIP Talker,<sup>™</sup> a line at the bottom of the screen, always tells you exactly where you are. And Help is just two keystrokes away.

## Now MBASIC really ZIPs.

The MBASIC version goes further and gives your programs the same screen handling characteristics that ZIP has, by writing a piece of itself in MBASIC so that you can use it in any of your programs.

The operator can use the arrows, etc. during data entry and conveniently jump back and forth between the input fields.

You can specify field lengths, or let ZIP default to the available space. Either way, text and prompts are protected no matter what kind of terminal you have, so the operator can't write over the fields and prompts.

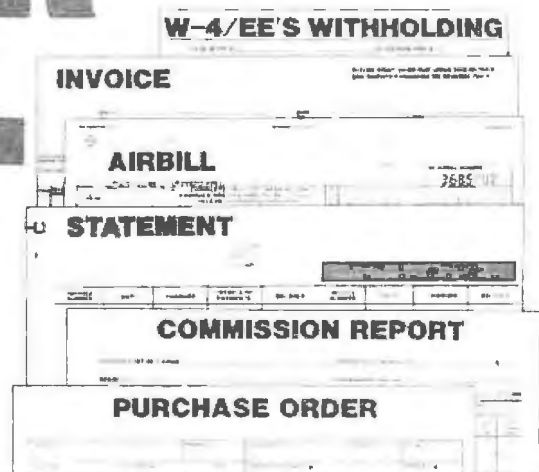

```
.....
NEW CUSTOMER
.....
CUSTOMER NAME: ;Customer$          DATE: @Date
MAIL ADDRESS: ;Addr1$;30
CITY: ;Addr2$
STATE: ;Addr3$      ZIP: ;Zip1;5
SHIP ADDRESS: ;Addr4$;30
CITY: ;Addr5$
STATE: ;Addr6$      ZIP: ;Zip2;5
DISCOUNT CATEGORY: ;Rate!
THE CODE FOR THIS NEW CUSTOMER IS @CustCode.
↓
Row 17, Col 36
```

You get the MBASIC code for a "Talker" that you can use to pretty up your program prompts. And easy, one-line data validation is built in.

## Join thousands of users ZIPPING along.

All you need is an 8-bit micro with CP/M or MP/M, 48k of memory and a 24x80 ASCII or ANSI terminal (Osborne I and 56k Apple okay, too).

The MBASIC and CBASIC versions are \$160 each (\$225 for both) plus \$7 shipping (VISA, MasterCard or money order). The dBASE II version is available alone from Ashton-Tate (213-204-5570), or we'll sell you dBASE II with ZIP for \$650. For more information, contact Nexus, 5455 Wilshire, Suite 802, Los Angeles, CA 90036.

Or if you'd like to end the paper chase sooner, just call 800-227-3747. (In California, call 213-937-0554, add 6% tax.)



from **Nexus**  
The man-machine connection.

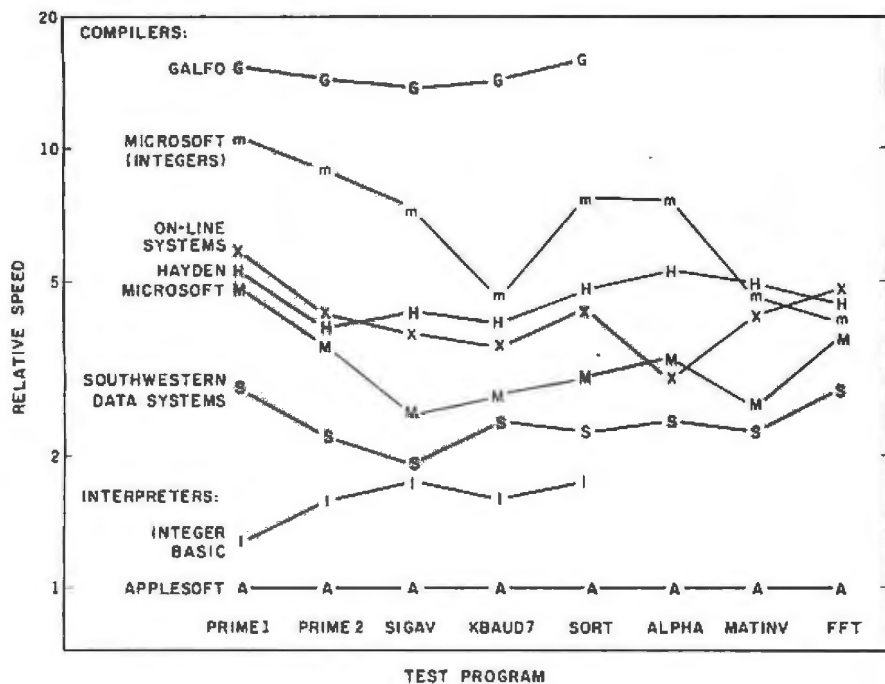

Figure 1: Relative speed of eight test programs when run directly with the Apple computer interpreters and after compiling them with each of five compilers. The speeds are normalized to a value of 1.0 for the Applesoft interpreter. Two sets of data are given for the Microsoft compiler; those denoted by lowercase m were obtained by including an Integer declaration for all numeric variables used as integers.

times faster than interpreted Integer BASIC, and 14 to 18 times faster than interpreted Applesoft BASIC. On the other hand, Integer BASIC does not allow string arrays and cannot be used easily for such purposes as inverting a matrix, computing a Fourier transform, or handling accounts-receivable-type functions. Such techniques as these, used frequently in scientific, statistical, and business applications, are better dealt with by Applesoft BASIC.

Of the Applesoft compilers, Microsoft's TASC produced the fastest code by a substantial margin for those programs with which its Integer option could be used effectively. The Hayden Applesoft Compiler and Expediter II were closely grouped in second and third place, followed by TASC (without invoking the Integer option) and Speed Star. For programs requiring floating-point calculations (such as MATINV and FFT), the performance of the compilers was more uniform, largely because all of them

Text continued on page 454



## SA2 ROBOT

\$999

The SA2 is a robot developed for the educational market, and has been designed to meet a requirement for a robot which will emulate, in behaviour and physical attributes, larger industrial robots.

The arm can access 360° with a reach of 18 inches and a maximum lift of 1/2 lb.

## The Syntheasy

A low cost speech unit complete with Votrax speech output chip, unlimited vocabulary, power supply, speaker and case, all for only-

\$120



For further information contact  
**INTELLIGENT ARTEFACTS LTD.**  
 19205 Parthenia St., Suite H  
 Northridge, CA 91324 Tel (213) 993-4803

FREE SHIPPING



**our TRS80<sup>®</sup> - MOD III**  
 48K, 2 TANDON 5 1/4"  
 DISK DRIVES (No. RS232)

\$1735

RS232 - \$99.95



**APPLE II Compatible Disk**  
 DRIVE - w/Cabinet & Cable - \$375  
 16K RAM CARD FOR APPLE - 75

**IBM/TRS 80 Disk Drive**  
 w/Cabinet and P/S  
 (TM100-1 TANDON) - \$260





**EPSON PRINTERS**

MX80 - \$435  
 MX80F/T - 535  
 MX100 - 685

SMITH-CORONA TP-1  
 LETTER QUALITY-DAISY WHEEL - \$635

**DATA-MAIL**  
 P.O. Box 818 Reseda  
 Calif 91335

VISA, MASTERCARD (\$100 Min. Add 2%) Or  
 Certified Check. Ninety Day Warranty.  
 Parts & Labor. TPS is a Registered Trademark.  
 Tandy Corp. Prices Subject to Change  
 Without Notice. **FREE SHIPPING IN**  
**CONTINENTAL U.S. (TRS MOD II EXCEPTED)**  
 (213) 993-4804

# DON'T PAY MORE

THAN YOU HAVE TO FOR YOUR  
**CP/M® AND IBM® SOFTWARE!**  
**AND GET TOLL-FREE TECHNICAL  
 SUPPORT TO BOOT!**

## CP/M

## IBM

<b>dBASE II</b> <b>CALL</b> ASHTON-TATE	<b>WORDSTAR</b> <b>\$279</b> MICROPRO	<b>SUPERCALC</b> <b>\$199</b> SORCIM	<b>CROSSTALK</b> <b>\$119</b> MICROSTUF
<b>QUICKCODE</b> <b>\$229</b> FOX & GELLER	<b>MAILMERGE</b> <b>\$89</b> MICROPRO	<b>THE WORD</b> <b>\$59</b> OASIS	<b>C BASIC 2</b> <b>\$99</b> DIGITAL RESEARCH
<b>SPELLBINDER</b> <b>\$279</b> LEXISOFT	<b>T/MAKER II</b> <b>\$209</b> LIFEBOAT	<b>SUPERVYZE</b> <b>\$65</b> EPIC	<b>CONDOR 20-II</b> <b>\$509</b> CONDOR

<b>SPELLGUARD</b> <b>\$239</b> I.S.A.	<b>WORDSTAR</b> <b>\$279</b> MICROPRO	<b>SUPERCALC</b> <b>\$199</b> SORCIM
<b>EASYSPELLER</b> <b>\$139</b> I.U.S.	<b>MAILMERGE</b> <b>\$89</b> MICROPRO	<b>CONDOR 29-II</b> <b>\$509</b> CONDOR
<b>EASYWRITER II</b> <b>\$289</b> I.U.S.	<b>CROSSTALK</b> <b>\$119</b> MICROSTUF	<b>TIM III</b> <b>\$399</b> I.S.I.

### ACCOUNTING PLUS®

General Ledger	
Accounts Payable	
Accounts Receivable	
Payroll	
Inventory	
Sales Order Entry	
Purchase Order Entry	
Point of Sale	
1 MODULE	\$ 400
2 MODULES	750
3 MODULES	1109
4 MODULES	1465
5 MODULES	1820
6 MODULES	2140
7 MODULES	2440
8 MODULES	2720

### DIGITAL RESEARCH

MAC	85
SID	65
ZSID	90
TEX	90

DESPOOL	\$ 45
PL/1-80	449
BT-80	175
PASCAL MT+	425
CB-80	419
CBASIC 2	99

### FOX & GELLER®

Quickscreen	139
dUTIL	69

### LIFEBOAT®

T/MAKER II	209
GRAFTALK	399
RBTE-80	649

### MICRO - AP®

S-Basic	269
Selector IV	399

### MICROCRAFT®

Legal Billing	495
Time Billing	495
Legal Billing Demo	75
Time Billing Demo	75

### MICROPRO®

Wordstar	\$279
Mailmerge	89
Spellstar	159
Datastar	249
Calcstar	219
Supersort	199
Customization Notes	349
Wordmaster	119

### MICROTECH EXPORTS®

REFORMATTER	199
CP/M - IBM	
CP/M - DEC	

### MICROSOFT®

Basic 80	284
Basic Compiler	325
Fortran 80	345
Cobol 80	569
Macro 80	144
Edit 80	84
MU Math/MU Simp	219
MU Lisp/MU Star	165
M-Sort	129

### PICKLES & TROUT®

CP/M	\$179
CP/M (Hard Disk)	259

### SORCIM®

Supercalc	239
-----------	-----

### DATA BASE®

FMS-80	649
CONDOR 20-I	249
CONDOR 20-II	509
CONDOR 20-III	839
CONDOR 20-R	249
CONDOR 20-Q	149

### XEROX 820 ACCESSORIES®

DUAL DENSITY BOARD	395
SERIAL PRINTER DRIVER	99
SMARTERM	129
PARALLEL PRINTER SOFTWARE	129

### ORDER INFO.

MASTERCARD, VISA, C.O.D.

3% DISCOUNT ON PREPAYMENT  
 MADE BY CHECK  
 (SOFTWARE ONLY)

ALL ITEMS SUBJECT TO AVAILABILITY  
 AND PRICE CHANGE

## standard software CORPORATION OF AMERICA

10 MAZZEO DRIVE, RANDOLPH, MA. 02368

**617-963-7220**

**800-343-0852**

Hours:

Mon.-Fri. 8 a.m.-8 p.m. E.S.T.

Sat. 9 a.m.-4 p.m.

PURCHASE ORDERS ACCEPTED

FROM QUALIFIED CORPORATIONS AND INSTITUTIONS.



CP/M® is a Trademark of Digital Research



# MuSYS gives S-100 the best in networks...

## with TurboDOS\*

With CP/M\* compatible TurboDOS and MuSYS network slave boards you can turn any Z80-based, S-100 system into a superior multi-processor, multi-user network.

TurboDOS is faster than CP/M for system functions. TurboDOS supports larger files (134 MB) and disks (1048 MB) and, unlike CP/NET\*, it's compatible with nearly all 2.2 applications software. Many features which are optional, extra cost or not available at all in CP/M are standard with TurboDOS. Add a MuSYS NET/82\* and you've got a complete, hardware isolated network slave including Z80A CPU, two serial ports and many other advanced features. For special applications an additional bank of 64K memory is available.

Expand your S-100 system economically with MuSYS now! Ask for all the facts on TurboDOS and our expanding line of network slave boards.

(Generous quantity/dealer discounts available.)

\*TurboDOS is a trademark of Software 2000, Inc. CP/M and CP/NET are trademarks of Digital Research, Inc. NET/82 is a trademark of MuSYS Corp.

**MuSYS**  
CORP  
Specialists in Multi-user Microsystems

1451 Irvine Blvd., Suite 11  
Tustin, CA 92680  
(714) 730-5692  
TWX: 910-595-1967  
CABLE: MUSYSTSTN

**Mini/Micro**

Computer Conference and Exhibition / September 14-16,  
Disneyland Hotel / Anaheim, California

See us at Booths 5013, 5015

Listing 6: ALPHA performs a string comparison and sort.

```

100 REM *****
110 REM * ALPHA *
120 REM *****
130 HOME
140 B$ = CHR$(7)
150 INPUT "READY ? ";A$
160 PRINT "START" + B$
170 DIM A$(40)
180 FOR I = 1 TO 40: READ A$(I)
190 IF A$(I) = "ZZZ" GOTO 210
200 NEXT I
210 N = I
220 S = 0
230 FOR I = 2 TO N
240 IF A$(I - 1) < = A$(I) THEN 290
250 Z$ = A$(I - 1)
260 A$(I - 1) = A$(I)
270 A$(I) = Z$
280 S = 1
290 NEXT I
300 IF S = 1 THEN 220
310 PRINT B$ + "STOP": PRINT
320 K = 0
330 FOR I = 1 TO N
340 PRINT TAB(12 * K + 1);A$(I);
350 K = K + 1: IF K < 3 GOTO 380
360 K = 0
370 PRINT
380 NEXT I
390 END
400 DATA NOTE, THAT, THE, ORDER, OF
410 DATA SORT, CAN, BE, CHANGED, FROM
420 DATA ASCENDING, DESCENDING, BY
430 DATA MAKING, GREATER, THAN, TEST
440 DATA IN, LINE, LESS, ALSO, SAYS
450 DATA REPEAT, LOOP, FOUR, TIMES
460 DATA FIVE, DUE, FACT, LOOKS, AHEAD
470 DATA ONE, STEP
480 DATA ZZZ

```

Listing 7: MATINV inverts a 10 by 10 matrix.

```

100 REM *****
110 REM * MATINV *
120 REM *****
130 REM
140 DIM A(15,15), B(15,15), C(15,15)
150 DIM IK(15), JK(15)
160 B$ = CHR$(7)
170 HOME : NN = 10
180 PRINT "GENERATING 10 X 10 MATRIX"
190 FOR I = 1 TO NN: FOR J = 1 TO NN
200 A(I,J) = RND(1)
210 B(I,J) = A(I,J): NEXT J
220 NEXT I
230 INPUT "READY ? ";A$
240 PRINT "START" + B$
250 GOSUB 10000
260 PRINT B$ + "STOP"
270 PRINT "CHECKING RESULTS ..."
280 FOR J = 1 TO NN: FOR K = 1 TO NN
290 S = 0
300 FOR M = 1 TO NN
310 S = S + A(J,M) * B(M,K): NEXT M
320 C(J,K) = S
330 NEXT K: NEXT J

```

Listing 7 continued on page 452

← Circle 333 on inquiry card.



**YOU CAN MAKE A FORTUNE IN MICROS!**

# THE MICRO COMPUTER BUSINESS WILL GROW FROM \$10 TO \$100 BILLION IN THE NEXT EIGHT YEARS! ARE YOU READY TO CASH IN?

The micro computer business is predicted to grow from its present \$10 billion to \$100 billion before 1990! Imagine the possibilities this opens for you! No matter where you live, if you're starting up or presently in business, no other industry offers you more opportunities!

Now, finally, all the inside information you need to secure a prosperous future in this dynamic industry is available in one place - **THE COMPUTER ENTREPRENEUR MANUAL!** - An immense information source, compiled by our inquisitive research team, aided by a panel of experts and business people from all areas of the computer industry!

We present the inside story of more than 100 lucrative computer businesses you can enter, where you'll find the real opportunities for the eighties: from one man operations like **Programming Author, Word Processing Center or Consulting, to Systems House, Service Bureau, Computer Store** etc! Many at little or no investment! All the invaluable facts and figures: **How to start, Capital needs, Profit estimates and Margins, How to Sell and Market, How missing technical or business experience need not stand in your way, Source of Suppliers,** etc! Details that could take years to find out on your own!

We'll show you **inside tricks**, like how to never again pay retail for computer products and consumer electronics, even for one item - right now, while you're starting your business! How to get free merchandise and trade show invitations, etc. This alone will more than pay for the manual! You'll read actual case histories of other computer entrepreneurs, so you can learn from their mistakes, and profit from their success stories! Where you'll be one year from now depends on your actions today! Let us show you how to take the first crucial steps!

Order now and take advantage of our limited introduction special, **THE COMPUTER ENTREPRENEUR MANUAL**, and a six month subscription to **THE COMPUTER ENTREPRENEUR REPORT/NEWSLETTER** (so you're always up-to-date with the industry), both for only **\$29.95!** You must be convinced on how easy you can strike it rich in the micro computer business - or you may return the manual for a full refund within thirty days! **USE OUR TOLL FREE NUMBER TO ORDER!**

## EVERYTHING YOU NEED TO KNOW TO SUCCEED IN THE COMPUTER BUSINESS IS ALL IN THIS MANUAL!

**THE COMPUTER ENTREPRENEUR MANUAL** has the answers to all your questions about selecting, starting and successfully running a computer business! There has never been such a comprehensive collection of know-how and information about this business in one place! All the facts you need to plan and achieve your goals in easy-to-follow, step-by-step instructions!

These are some of the 100-plus businesses covered in **PART ONE** of the manual, with the facts on **How to start and run, Start-up Cost** (Even how to operate on a shoestring), **What profits to expect, Wholesale prices, Mark-ups, Suppliers, future outlook, case histories** for each, etc:

**Systems House, Software Author** (who to sell to and who to avoid), **Service Bureau, Software Publisher** (How to find programs that sell, **Word Processing Service, Consulting and Consultant Broker** (use your skills or those of others, make \$150 - \$1000 a day!), **The Incredible Games Business, Computer Store** (Franchises, Pro and Contra, or a low inventory store in your home!), **OEM, Hardware Mfg, Data base and Teletext Service** (big prospects!), **Used Computers, Repairs, Rent-A-Computer, Promote Fests and Trade Shows, Turnkey Systems,**

**Bartering, Mail Order, Compile and rent mailing lists, Specialized Data Headhunting and Temp Help Service, Tech Writer Shop, Custom Engineering, The highly profitable Seminars and Training Business,** and many more!

Many new ideas and ground floor opportunities! Interviews and success stories on companies of all sizes! **Privy info on the profits made:** How some computer store operators net \$100 - \$250,000! Little known outfits that made their owners millionaires, one of these low-key companies, making simple boards, went from nil to \$20,000,000 and 100 employees in four years! Programmers that make \$300,000. Thousands of micro millionaires in the making, etc!

Whatever your goal is - **Silicon Valley Tycoon, or just a business at home** - we guarantee you'll find a business to suit you - or your money back!

**PART TWO** of the manual is loaded with the know-how and "streetfighting" savvy you need, both as a novice or business veteran, to get started, to stay and to prosper in the micro computer business! A goldmine of information in clear and easy-to-use instructions! **How to prepare your Business Plan, Outside financing, The mistakes you must avoid, How to hire and manage employees, Incorporation** (when, and how to do it cheaply), **Surviving bad times, Record Keeping, how to estimate your market before you start, Use multiple locations to maximize profits, how to promote and stay steps ahead of the competition!** How to get free advertising, free merchandise, free advice, **Power negotiating** with suppliers to double your profit margins, etc! Even how to keep a present job while starting a business part time!

Don't miss this opportunity to be part of this great industry - the next success story could be your own! Order the manual today! Part one and two, bound in a deluxe ring binder, where you can also collect our newsletter (free for six months with the manual - a \$32.50 value!) - all for only \$29.95!



### THE COMPUTER ENTREPRENEUR NEWSLETTER - ALL THE LATEST INSIDE BUSINESS NEWS! NOW! SIX MONTHS FREE WITH YOUR MANUAL!

You're always attuned to the industry and your manual kept up-to-date, with our newsletter! Each issue has the latest business news, ideas, new suppliers, our indispensable "watchdog" column on profits, discounts (don't miss mfg's promos, like recently when top video moni for sold at \$80 - that's half wholesale, one third of the retail price!), the competition, the big deals, etc! Feature stories with start-up info and case histories on new micro businesses!

You'll get invitations to trade shows and conventions the usage of our advisory service and our discount buying service for your purchases!

You'll find many items in our newsletter that will save you the cost of your manual many times over!



**CALL TOLL FREE! CHARGE IT!**  
Credit Card Orders (MC, VISA only) accepted 24 hours/day  
1-800-227-3800  
Ask for extension 1136  
In California call 1-800-792-0990



Order by phone (Credit cards only), or use the coupon:

Mail to **THE COMPUTER ENTREPRENEUR PUBLISHING CO.**  
PO BOX 5543, Grand Central Station, New York, N.Y. 10017  
Please send me **THE COMPUTER ENTREPRENEUR MANUAL**, and the six month free subscription to **THE COMPUTER ENTREPRENEUR REPORT/NEWSLETTER**. All for only \$29.95, plus \$3 for postage/handling (NY residents: add \$2.64 for sales tax) If I decide not to keep the manual, I may return it within 30 days for a full refund.

NAME: \_\_\_\_\_  
ADDRESS: \_\_\_\_\_  
CITY, STATE, ZIP: \_\_\_\_\_  
 Check or M.O. enclosed Charge to  VISA  MC  
CARD# \_\_\_\_\_  
Exp. Date: \_\_\_\_\_  
SIGNATURE: \_\_\_\_\_

B91



# AIMING TO PLEASE

If you know anything at all about Computer Furniture and Accessories, you know that we bend over backwards to make our customers happy. That's why we'll modify our standard line of computer desks and accessories to meet your special requirements. With custom tops and desk configurations, special data shelves, micro shelves, risers, keyboard recesses, cable cut-outs and paper slots, as well as custom paint and top laminate colors. At CF&A you get all this plus durable construction, reasonable cost, and personal service. More than ever, CF&A is aiming to please.

# CF&A

**Computer Furniture and  
Accessories**  
515 West 132nd Street  
Gardena, CA 90248  
(213) 327-7710

**Houston Warehouse:**  
Hamilton and Associates  
8050 El Rio  
Houston, TX 77054  
(713) 741-1505

Listing 7 continued:

```

340 PRINT : PRINT "DIAGONAL OF PRODUCT:"
350 FOR I = 1 TO NN
360 PRINT I; TAB( 6);C(I,I)
370 NEXT I
380 END
10000 REM *****
10010 REM * MATINV SUBR *
10020 REM *****
10030 DET = 1
10040 FOR K = 1 TO NN
10050 AM = 0
10060 FOR I = K TO NN
10070 FOR J = K TO NN
10080 IF ( ABS (AM)) > ABS (A(I,J)) GOTO 10120
10090 AM = A(I,J)
10100 IK(K) = I
10110 JK(K) = J
10120 NEXT J: NEXT I
10130 IF AM < > 0 GOTO 10150
10140 PRINT "ZERO MATRIX -- ABORT": END
10150 I = IK(K)
10160 IF I = K GOTO 10220
10170 IF I < K GOTO 10060
10180 FOR J = 1 TO NN
10190 S = A(K,J)
10200 A(K,J) = A(I,J)
10210 A(I,J) = - S: NEXT J
10220 J = JK(K)
10230 IF J < K GOTO 10060
10240 IF J = K GOTO 10290
10250 FOR I = 1 TO NN
10260 S = A(I,K)
10270 A(I,K) = A(I,J)
10280 A(I,J) = - S: NEXT I
10290 FOR I = 1 TO NN
10300 IF I = K GOTO 10320
10310 A(I,K) = - A(I,K) / AM
10320 NEXT I
10330 FOR I = 1 TO NN
10340 FOR J = 1 TO NN
10350 IF I = K GOTO 10380
10360 IF J = K GOTO 10380
10370 A(I,J) = A(I,J) + A(I,K) * A(K,J)
10380 NEXT J: NEXT I
10390 FOR J = 1 TO NN
10400 IF J = K GOTO 10420
10410 A(K,J) = A(K,J) / AM
10420 NEXT J
10430 A(K,K) = 1. / AM
10440 DET = DET * AM: NEXT K
10450 FOR L = 1 TO NN
10460 K = NN - L + 1
10470 J = IK(K)
10480 IF J < = K GOTO 10530
10490 FOR I = 1 TO NN
10500 S = A(I,K)
10510 A(I,K) = - A(I,J)
10520 A(I,J) = S: NEXT I
10530 I = JK(K)
10540 IF I < = K GOTO 10590
10550 FOR J = 1 TO NN
10560 S = A(K,J)
10570 A(K,J) = - A(I,J)
10580 A(I,J) = S: NEXT J
10590 NEXT L
10600 RETURN

```

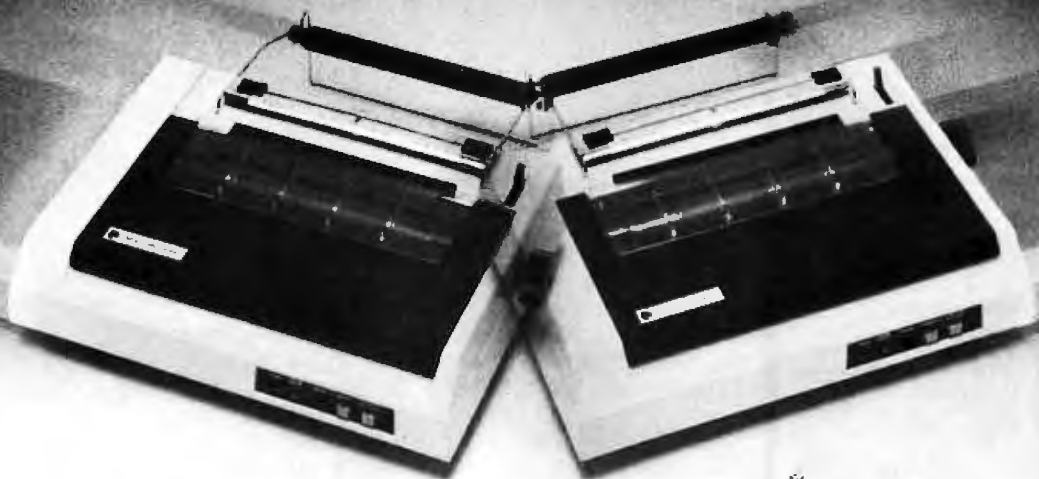

## PRINTS LIKE A DAISY... COSTS LIKE A MATRIX.

Integral Data Systems introduces the only low-cost dot matrix printer on the market that features Maisey™ printing. Maisey printing is a technique that allows you to produce correspondence-quality text approaching that of more expensive daisy-wheel printers, but at much faster speeds.

How fast? With Microprism Printer's™ dual speed capability, you can output at 75cps in correspondence-quality and 110cps in high-speed data mode. And it also features sharp, high-density graphics in an 84 x 84 dpi format.

You'll get cleaner, crisper output than you ever thought possible in a single pass.

Other standard features of the Microprism include proportional

spacing, text justification and, of course, software compatibility with our more expensive Prism Printer™ line.

The Microprism Printer is the perfect system mate that can handle all of your printing requirements... it's the best of both worlds. So if you've been waiting for the price of daisy-wheel printers to come down, or the quality of dot matrix to go up, now is the time to check out the exciting new Microprism Printer from Integral Data Systems.

Stop in at your local dealer today and ask for a demonstration. If you need the name of the dealer nearest you, call us toll-free at (800)258-1386.

Or write Integral Data Systems, Milford, NH 03055.



Integral Data Systems, Inc.

Microprism Printer, Prism Printer and Maisey are registered trademarks of Integral Data Systems, Milford, NH.

Circle 237 on inquiry card.



keeps you in step with the fast-paced, dynamic world of COMPUTERS!

**55 Advanced Computer Programs In BASIC**

A comprehensive collection of ready-to-run programs for the TRS-80 Level II with 16K and other BASIC computers: mathematics, business, personal management, game, and simulation programs. 252 pp., 78 illus. Hardbound. Publisher's List \$16.95. Order No. 1295.



**Programming Your Apple II™ Computer**

A must-have sourcebook for every Apple II owner or prospective owner. Contains all the how-to's for getting the most performance out of your machine with the least amount of time and programming effort. 300 pp., 39 illus. Hardbound. Publisher's List \$15.95. Order No. 1394.



**Microprocessor Interfacing**

Complete and up-to-date guide to the newest configurations in microprocessor/microcomputer design; shows how to apply digital techniques for a wide range of electronic purposes. For experimenters and programmers. 252 pp., 263 illus. Hardbound. Publisher's List \$13.95. Order No. 1396.



**How To Get Started With CP/M**

Practical introduction to Control Program/Monitor (CP/M), a system that provides more efficient management of your software and hardware resources... shows you how to get programs from disk, tape, or paper into the computer where you can use them! 140 pp., 12 illus. Hardbound. Publisher's List \$14.95. Order No. 336.



Free Catalog Available  
Dealer Inquiries Invited

**TAB** TAB BOOKS Inc.  
Blue Ridge Summit, PA 17214

Send the following books:  
No. \_\_\_\_\_ No. \_\_\_\_\_ No. \_\_\_\_\_ No. \_\_\_\_\_  
Check enclosed in the amount of \$ \_\_\_\_\_  
For Charge orders, call Toll Free:  
800-233-1128 (Pennsylvania, Alaska,  
Hawaii, call direct: 717-794-2191)  
\_\_\_\_\_ Visa \_\_\_\_\_ Mastercharge  
Acct. No. \_\_\_\_\_ Expires: \_\_\_\_\_  
Signature \_\_\_\_\_  
Name \_\_\_\_\_  
Address \_\_\_\_\_  
City \_\_\_\_\_  
State \_\_\_\_\_ Zip \_\_\_\_\_

BYDM-982

Listing 8: FFT computes the discrete Fourier transform of a 64-point complex array.

```

100 REM *****
110 REM * FFT *
120 REM *****
130 DIM D(1024):IS = - 1
140 HOME : PRINT "GENERATING DATA"
150 B$ = CHR$( 7)
160 NZ = 64: PRINT "LENGTH:";NZ
170 P = 8: PRINT "PERIOD:";P:NF = NZ / P
180 FOR I = 1 TO NZ:J = I + I - 1
190 D(J) = SIN (6.283185307 * (I - 1) / P)
200 D(J + 1) = 0: NEXT I
210 INPUT "READY ? ";A$
220 PRINT "START" + B$
230 GOSUB 10000: REM CALL FOUR1(D,NZ,IS)
240 PRINT B$ + "STOP"
250 FOR I = 1 TO NZ / 2 + 1
260 J = I + I - 1
270 A = D(J)
280 B = D(J + 1)
290 PRINT I; TAB( 4);A; TAB( 20);B
300 NEXT I
310 END

10000 REM *****
10010 REM * FOUR1 *
10020 REM *****
10030 REM
10040 P0 = 2:P3 = P0 * NZ:R3 = 1
10050 FOR I3 = 1 TO P3 STEP P0
10060 IF I3 > = R3 GOTO 10100
10070 TR = D(I3):TI = D(I3 + 1)
10080 D(I3) = D(R3):D(I3 + 1) = D(R3 + 1)
10090 D(R3) = TR:D(R3 + 1) = TI
10100 P1 = INT (P3 / 2)
10110 IF R3 < = P1 GOTO 10140
10120 R3 = R3 - P1:P1 = INT (P1 / 2)
10130 IF P1 > = P0 GOTO 10110
10140 R3 = R3 + P1: NEXT I3
10150 P1 = P0
10160 IF P1 > = P3 THEN RETURN
10170 P2 = P1 + P1:TH = 6.283185307 / (IS * P1)
10180 S = SIN (0.5 * TH):ZR = - 2 * S * S:ZI = SIN (TH)
10190 WR = 1.0:WI = 0.0
10200 FOR I1 = 1 TO P1 STEP P0
10210 FOR I3 = I1 TO P3 STEP P2
10220 J0 = I3:J1 = J0 + P1:TR = WR * D(J1) - WI * D(J1 + 1)
10230 TI = WR * D(J1 + 1) + WI * D(J1):D(J1) = D(J0) - TR
10240 D(J1 + 1) = D(J0 + 1) - TI:D(J0) = D(J0) + TR
10250 D(J0 + 1) = D(J0 + 1) + TI
10260 NEXT I3
10270 TR = WR
10280 WR = WR * ZR - WI * ZI + WR
10290 WI = WI * ZR + TR * ZI + WI
10300 NEXT I1
10310 P1 = P2: GOTO 10160
    
```

Text continued from page 448:

call on subroutines within the Apple-soft interpreter for floating-point operations and especially for evaluating functions such as SQR, SIN, and LOG. For programs that use these functions, Hayden and Expediter II came out in the lead, marginally ahead of TASC, with Speed Star again bringing up the rear.

Compiled versions of very long programs, particularly if many vari-

ables are used, will generally exhibit an even faster relative speed, compared to the interpreted BASIC versions. This is because interpreters have to search through tables for variable names and line numbers whenever they are encountered during program execution. The compilers, on the other hand, perform the necessary lookups only at compilation time, inserting the appropriate addresses into the object code. We

# Are your operators making computer errors with their feet?

As they walk and move about, your operators build up a static charge.

Just by taking a couple steps across the floor in a well air-conditioned room, they can generate 5,000 volts or more.

Or, in the wintertime, 10,000 volts or more.

Static can also be generated just by sitting down in a chair.

And if the operator's next move is to touch one of your terminals, the result can be a blank screen, erratic data, spewing paper, or an altered memory.

Another result can be annoyed customers.



*3M Static Control Floor Mats create an island of protection.*

But, for less than the cost of a single service call, you can effectively control static at every terminal, every word processor and microprocessor-based unit.

*With 3M Static Control Mats, you keep static from coming between you and your customers.*



3M Static Control Floor Mats and Runners create inexpensive islands and pathways of protection around and between sensitive areas. Static charges drain harmlessly from operators and other personnel as they walk, stand or sit.

Available in a choice of colors, and in many sizes, 3M Static Control Mats are carefully engineered for performance, comfort, durability, ease of

cleaning and safety. For standing and sitting applications.

**Send the coupon for a free catalog and more information.**

Send coupon to: Data Recording Products Division/3M, 223-5N, 3M Center, St. Paul, MN 55144. Or, if you've already put up with static problems too long, call this toll-free number for the name of a distributor or dealer near you: 1-800-328-1300.



*Free catalog shows 3M's complete selection of mats and runners.*

3M Please send free catalog and other information on Static Control Mats and Runners

NAME \_\_\_\_\_

COMPANY \_\_\_\_\_

ADDRESS \_\_\_\_\_

CITY STATE ZIP \_\_\_\_\_

Mail to: Data Recording Products Division/3M,  
223-5N 3M Center,  
St. Paul, MN 55144

**3M Hears You...**

# 3M

## HOT PRICES! FAST SERVICE!

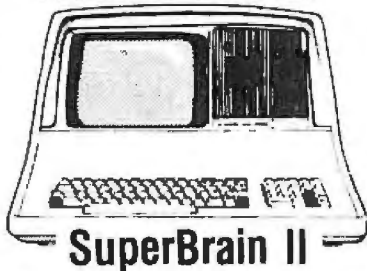

### SuperBrain II

Model	List	Our Price
SB II 350K byte	\$2495	\$1875
SB II QD 750K	\$2995	\$2250
SB II SD 1 mb	\$3495	\$2750

## NEC

- Low prices, big features
- Color output
- Real time clock
- CP/M compatible • 5 function keys

Model	List	Our Price
PC8001A Computer	\$995	\$735
PC8012A I/O with 32K	\$649	\$475
PC8031A Dual 5 1/4" drives	\$995	\$735
ALTOS Computers	Call for Price	
NORTHSTAR Computers	Call for Price	

## PRINTERS

Model	List	Our Price
NEC 8023A	\$795	\$479
Dkidata Microline 82A	\$649	\$474
Dkidata Microline 83A	\$995	\$724
Dkidata Tractor Option	\$65	\$59
C. Hoh 8510 ProWriter	\$795	\$530
C. Hoh F-10 40cps	\$1995	\$1449
NEC 3510 or 3530	\$2295	\$1869
NEC 7710 RS232 55cps	\$3085	\$2375
NEC 7730 parallel 55 cps	\$3085	\$2375

## MODEMS

Model	List	Our Price
Hayes Micromodem II I/Apple	\$379	\$290
Hayes Smartmodem	\$279	\$219
CAT Acoustic	\$190	\$149
D CAT direct connect	\$199	\$159

## TERMINALS

Call for Prices

Wordstar for Apple	\$220
Wordstar for CP/M	\$295
MailMerge	\$89
CalcStar	\$175
SuperCalc	\$195
VisiCalc for Apple	\$185
dBase II	\$475
Spellguard	\$157

## APPLE ITEMS

Z-80 Softcard w/CP/M & manual	\$285
16K RAM Card	\$139
80-column Card (Videoterm)	\$225

To Order Call (206) 362-3398

Mail & telephone orders only. Mastercharge, VISA add 3%. Sorry, No COD

# PACIFIC COMPUTERS

Division of Mickel & Assoc.

11056 Palatine N.  
Seattle, WA 98133

note, however, that the relative speed rankings among the compilers is approximately the same because each compiler gains equally from this inherent advantage over the interpreters.

It is interesting to comment on two apparently anomalous dips shown in the data of figure 1; they reveal peculiarities of the TASC and Expediter II compilers. TASC (with the Integer option enabled for all variables) was not outstanding when running the KBAUD7 benchmark, compared to most of the other test programs, because KBAUD7 includes a division operation. As described in the TASC manual, all integer divisions are done by converting to floating point and back again. Therefore, in integer divisions, the program does not gain the speed advantage of true integer arithmetic. Expediter II performed relatively poorly in executing program ALPHA, which tests string handling. Unlike the other compilers, Expediter II allocates space for strings statically (at compilation time) rather than dynamically (at execution time), and its string-handling algorithm appears to be inefficient. (For those interested in details, Expediter II's performance on program ALPHA improved only slightly when its default string size of 40 characters was explicitly reduced to 10.)

### Operation and Documentation

We found that all of the compilers were very easy to use on short programs. We had little difficulty in making them perform as advertised when compiling the benchmarks. Longer and more complicated programs may be a different matter, though. A compiled language has some intrinsic differences from an interpreted one—such as static, rather than dynamic, allocation of variable space and static definition of functions. In addition, cassette-tape operations are not supported by the compilers, in general, and Expediter II and Speed Star have not implemented the RESUME command. You should expect to have to make at least small changes in some programs to make them compile properly.

**Galfo Systems' Integer BASIC Compiler:** This compiler is furnished on two floppy disks. The "system" disk is in the standard DOS (disk operating system) 3.3 format and contains the 3.5K-byte run-time library and various utility programs. The second disk is in a nonstandard, copy-protected format and contains the compiler itself. Normal operating procedure begins with booting the Galfo system disk, which runs an appropriate Hello program and leaves the computer under control of the Integer BASIC interpreter. You then load the source program to be compiled (which must be an Integer BASIC file) and type "BRUN IBC" to begin the compilation process. On a one-drive system, you will be prompted appropriately for disk swaps.

IBC then asks three questions to establish compilation-time options. The most important of these options permits you to generate object code optimized either for fastest execution or for minimum program size. This feature is very nice; the fast code is very fast indeed but may be up to three times as long as the source program. In contrast, the compact code may actually be shorter than the source program. In our tests, the compact code executed only 10 to 20 percent more slowly than the fast code, though in some cases the speed penalty may be greater.

When compilation has finished, you can use the BSAVE command to save in binary format the object code on any standard DOS 3.3 disk. To run the compiled program, you use the BLOAD command to load in binary format the run-time library (if it is not already in memory) and then use the BRUN command to run in binary format the object file. Both the compiled code and the run-time library are relocatable by page and can be saved together as a single file if desired.

The Galfo instruction manual is thorough and complete, though not ornamentally packaged. (The 27 pages were reproduced from a dot-matrix printout.) An extensive section describes some very useful exten-

**New mbp  
COBOL  
Compiler  
for  
CP/M-86**

# Cuts run-time 75%! Or your money back!

Compared to interpreters, mbp's new COBOL Compiler for CP/M-86\* cuts 16-bit micros' program run-time 75%! With it, in one hour you can now run programs that used to take four. Put another way—it's like having four computers for the price of one. The dollar savings are obvious—and, awesome!

#### How is it possible?

An interpreter translates and executes a program one statement at a time—every time the program runs. But, the mbp COBOL Compiler translates an entire program just once; then the translated program can be executed as often as you want—*WITHOUT RETRANSLATION!* It's at least four times faster.

**We guarantee it**—or return the compiler and manual within 30 days for a complete refund.

#### And, it's COBOL—

the language for commercial and administrative applications. Standardized and maintained like no other language, COBOL opens up a whole range of benefits to business micro users that previously only mainframe and mini users enjoyed.

**mbp COBOL Compiler features:** meets ANSI '74 Standard ■ offers access to a vast selection of existing application software ■ real executable machine code—run-time and memory efficient ■ user-friendly (example: more than 500 error messages) ■ maximum portability protects software investments.

For application software developers, the run-time package is reasonably priced and available separately.

**Available now** for CP/M-86, iRMX-86,\* and ISIS;\* soon for OASIS-16,\* and MS-DOS.\*

With twenty-five years worldwide system software experience, for more than twelve years mbp has specialized

in custom COBOL implementations for mainframes and minis. Now, the mbp COBOL Compiler for CP/M-86 makes this valuable experience available to micro users. To take advantage of it, just send the coupon—or call Dieter Moenig, 415/632-1555—today.

Hardware required: 96K memory, hard disk & 8" floppy  
\*CP/M-86 is a Digital Research TM, iRMX-86 & ISIS, Intel TMs; OASIS-16, Phase One Systems TM; MS-DOS, Microsoft TM.

**mbp**  
SOFTWARE AND  
SYSTEMS TECHNOLOGY INC.

7700 Edgewater Drive, Suite 626  
Oakland, CA 94621

Phone 415/632-1555

Please send me

mbp COBOL Compiler for CP/M-86 (manual included): \$1400.  
I understand the compiler will cut my COBOL program execution time 75%, or I may return it (and manual) within 30 days for a full refund.  Manual only, \$95.

Free compiler information.  OEM information.

Check enclosed  UPS C.O.D.  VISA  Mastercharge  
(Add \$3 for shipping. California residents add sales tax.)

Card # \_\_\_\_\_ Exp. date \_\_\_\_\_

Signature \_\_\_\_\_

Name \_\_\_\_\_

Title \_\_\_\_\_ Company \_\_\_\_\_

Address (no PO Box #) \_\_\_\_\_

City \_\_\_\_\_ State \_\_\_\_\_ Zip \_\_\_\_\_

Visit us at Mini-Micro Anaheim

# WIRESMASTER

## A COMPILER FOR HARDWARE

Whip your wire wrap and PC layout problems with WIRESMASTER



● **WIRESMASTER** is a software tool to aid in the design, layout, and construction of electronic hardware. Although intended primarily for wire wrap, it is also highly useful in the layout, error checking, and trouble-shooting of PC boards.

● Inputs are easily derived directly from the schematic diagram and fed to **WIRESMASTER** in a CP/M\* text file. Outputs include a network map that graphically shows all pins and wires (no plotter required), a wire list sorted by lengths and levels, a parts list, signal and pin cross-references, and wrap count and continuity checklists which ensure a perfect wiring job.

● **WIRESMASTER** checks for syntax errors, wires that go nowhere, and duplicated pins. Network lengths are minimized, and wire lengths are calculated and sorted in descending order so that the shorter wires on top hold down the longer wires beneath for a neat wiring job.

● The resulting information is then used for wiring, PC board layouts, error-checking, component stuffing, and system debugging. This makes a complete and easily updated documentation package. Although it runs on small computers, **WIRESMASTER** can handle large projects.

● **WIRESMASTER** locates parts with a precision of .001 inch, keeps track of your schematic page numbers and includes them in the outputs, and can handle twisted pair and shielded wire.

● **CHANGEMASTER**, a companion program, eliminates the confusion and loss of control caused by changes to a board during debugging and modification. It outputs a map of all networks which have been added, deleted, or modified, and automatically generates REMOVE and ADD lists so an old board can easily be brought into exact conformance with the latest design.

● **WIRESMASTER** runs on any Z80\* CP/M system of 47K or larger, including S-100 systems, TRS-80\* Model II and Apple II\* with SoftCard\*. The diskette also includes a SORT utility, a pagination and multi-column printing program, and FIX, a program which finds all bad spots on a disk, tells you which files they are in, places the bad sectors in a single file, and recovers erased files.

● Post-processors for numerically controlled wire wrap machines such as the Gardner Denver SP-29 and others are available by special arrangement.

**WIRESMASTER** plus **CHANGEMASTER**... \$200  
Manual only... \$ 20  
Update to current version... \$ 25

Discount to computer club members

Versions for 8080/8085, CPM 86, CDOS, and IBM PC available soon.

### AFTERTHOUGHT ENGINEERING

7266 Courtney Drive  
San Diego, California 92111  
(714) 279-2868

\*Digital Research trademark

sions to Integer BASIC. One of the nicest extensions is a set of high-resolution graphics commands similar in effect, though not identical in syntax, to those used in Applesoft. These features, together with its speed, would seem to make Galfo-compiled Integer BASIC an attractive language to use for developing high-speed graphics and game-playing programs.

**Hayden Book Company's Apple-soft Compiler:** Furnished on a single 16-sector floppy disk (a 13-sector version is also available), the software is copy-protected and written to disk in nonstandard format. To use the compiler, you boot the disk; the program then asks for the name of an Apple-soft source file and prompts you to swap disks (if necessary for single-drive systems). It then requests an object filename, suggesting a default by preceding the source filename with BIN., as in BIN.PRIME1. Compilation then begins, the system agreeably keeping you posted on what it is doing by displaying flashing messages such as LOADING COMPILER, PARSING, SAVING OBJECT, and so on. The automatically saved object file includes a copy of necessary routines from the 3.3K-byte run-time library. To execute the program you press Reset, reboot the system, and use the BRUN command to run the saved object file.

The Hayden compiler has some useful features that help to streamline its generated code. Expressions and even subexpressions with integer operands are evaluated as far as possible with 16-bit arithmetic routines. Also, the compiler generates array-lookup vectors for multidimensional arrays, thereby avoiding many time-consuming multiplications when array elements are referred to at execution time. Several source programs can be compiled separately. They then call each other as modules or are called by interpreted Applesoft programs. However, the mechanism for sharing variables between programs is somewhat cumbersome and error prone.

The Hayden instruction book is professionally packaged in an attrac-

tive three-ring binder. The documentation is clear and informative, though perhaps somewhat sparse.

**Microsoft's TASC:** This compiler is furnished on a single 13-sector floppy disk. With a DOS 3.3 system, you must use the program Muffin to copy the five TASC files onto your own standard 16-sector disk. If you have only a single disk drive, you than have the desirable advantage of being able to put everything (compiler files, run-time library, source files, and object files) on the same disk, so that no swapping is required.

To compile a program, you type "RUN TASC." You will be asked for a source filename (e.g., PRIME1) and an object filename (which defaults, in this case, to PRIME1.OBJ). The compiler asks two questions that permit nonstandard memory-address assignments for the object code and nonstandard options concerning listings, error handling, and so on and then proceeds to compile the program. TASC is the slowest compiler we tested; very long programs required 10 minutes or more to compile. To run the compiled code, you must use the BLOAD command to load the run-time file and then use the BRUN command to run the object file.

Microsoft's instruction manual is superb. It is packaged in a handy loose-leaf binder and is 97 pages long. Chapters are arranged in order of increasing complexity, starting with a tutorial on what compilers can do. The manual gives detailed examples using TASC with a graphics demonstration program on the disk and covers advanced programming considerations such as optional use of the very powerful Integer declarations. The final chapter describes in detail the internal workings of the TASC compiler, including the interesting information that TASC was written in Applesoft and used to compile itself! (No, the source code is not included on the disk.) The Microsoft manual is the only one of the five to include an extensive index. It is a very professional piece of work.

**On-Line Systems' Expediter II:** Both 13- and 16-sector versions are furnished on a single floppy disk and

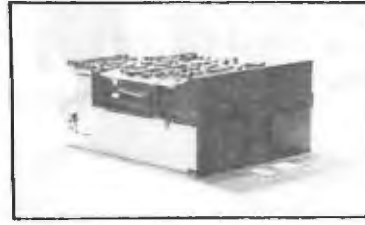

**NEW! Lowest Prices Anywhere . . .****SMITH  
CORONA  
-TP1****\$639.****\$299.****IBM PC<sup>TM</sup>  
INTERNAL  
FLOPPY  
DRIVES****TWO-SIDED  
320 K****LETTER QUALITY  
ELECTRONIC TEXT PRINTER**

An advanced microprocessor controlled daisy wheel printer — Fully formed letter quality printing — Speed—120 words per minute — Simple — Reliable — User "friendly" operator controls — Available with parallel or serial data interface — 10 or 12 characters per inch — Six fonts for each pitch — Handles single sheets or continuous forms up to 5 parts — Tractor optional — Noise level—63dB or better — 117 VAC or 240 VAC — 50/60 Hz.

**We'll  
beat  
any  
price!**

**SOFTWARE  
COMPATIBLE  
WITH IBM PC-DOS**

Also Available 1 sided 160-K . . .  
\$249.00. Tested, assembled, burned-in  
and re-tested before shipping.  
Ask about our external drives.

**To Order, Write . . . or Call Toll Free: 800-523-1449. in PA (215) 644-6341**

Terms of sale: bank wire transfer, certified or cashier's check, or money order. Please include telephone number with order. PA residents add 6% sales tax. Advertised price is for pre-paid orders FOB shipping point. Price subject to change without notice. Manufacturer's warranty only.

**IBM PC<sup>TM</sup> Trademark of IBM****SPECTRA MARKETING**

600 Swedesford Rd. Berwyn, PA 19312

**APPLE SPEAKS  
INTELLIGENTLY!**

The people who dared to teach Atari to talk are again challenging the microcomputer establishment with the VOICEBOX Speech Synthesizer for Apple. This low cost intelligent peripheral can speak thousands of words unassisted, generated directly from its firmware ROM dictionary located on its plug-in card. This means that speech, with variable intonation and speed, can be used in any of your apple programs without ever having to bother loading a disk. And, in case you want to expand your dictionary to include unusual words or words in foreign languages, you can easily define them with our 64 phonemes and store them by the thousands on one of the six special dictionaries provided for on our disk.

In addition your VOICEBOX for Apple can be easily coded to sing on key with uniform barlengths and you can store (record) your songs on disk, retrieving and modifying sections whenever you want. With the disk system, you'll also enjoy an educational random sentence generator and graphic speech animation! The VOICEBOX for Apple will run on 32K Apple II with Applesoft or Apple II Plus systems equipped with sixteen-sector disk drives. VOICEBOX for Apple comes with loudspeaker and disk. The Alien Group also makes a less expensive VOICEBOX for Apple with all features (including expandable disk dictionary), but excluding firmware ROM and singing capability. Speaker is optional on this unit.



For Atari users, the VOICEBOX for 16K and up Atari plugs directly into the serial port. No extra cables are needed and no speaker is needed since the speech comes directly over your TV monitor. This unit has all speech synthesis features except singing and firmware ROM.

AL-3001 VOICEBOX for Apple. With firmware ROM, singing capability and speaker \$215.00  
AL-3501 VOICEBOX for Apple. Without firmware ROM, singing capability and speaker \$139.00  
AL-4001 Speaker for AL-3501 (the AL-3501 will also work with any other speaker) \$15.00  
AL-5001 VOICEBOX for Atari \$169.00

All mail orders are on a 10 day moneyback guarantee if you're not completely satisfied. When ordering enclose check or money-order or state VISA or MASTERCARD number. Send mail orders to:

THE ALIEN GROUP	or Telephone orders
27 West 23rd Street	from 10 AM to 6 PM
Dept BT-3	New York time
New York, New York 10010	(212) 924-5546

ALSO AVAILABLE AT LEADING COMPUTER STORES  
THROUGHOUT THE WORLD.

written in a nonstandard format. To compile a program, you boot any standard DOS disk, load the desired Applesoft program, and type "BRUN EXPEDITER," changing disks if necessary before pressing Return. The compiler asks whether you want to accept the default compilation-time options and allows you to change them if desired. It then proceeds to compile the program. When compilation is finished, the Applesoft program has been replaced in memory by a single-line program, a CALL instruction to the starting address of the compiled code. The program can be run immediately or saved on disk if desired. The saved program will appear in a DOS catalog display as an Applesoft program, but actually it contains the single CALL statement together with the binary object code and the 2.3K-byte run-time library.

The Expediter II manual is paper covered, printed on gray stock, and adequate but not extensive. It contains little tutorial material, though we believe a first-time user will probably be able to understand it.

**Southwestern Data Systems' Speed Star:** This compiler comes on a 16-sector standard-format disk. Operation requires that a hardware key be plugged into the Apple paddle port. (The paddles can still be connected, piggyback style, because the key has a socket on its top.) To use Speed Star, you boot the disk or type "BRUN SPEEDSTAR." The compiler is loaded into memory, the HIMEM pointer is reset to protect the compiler, and you are left with standard DOS and the Applesoft interpreter in command. You may then load or otherwise enter any Applesoft program; to compile it you type the ampersand character (&), optionally followed by parameters specifying nonstandard addresses, etc. For programs of modest size, everything can be in RAM—Speed Star itself, the program to be compiled, and the generated object code—so no disk accesses are required, and compilation is extremely fast. These programs compile in a second or two! Very long programs may not compile at all, however, because of memory limita-



## EMPLOYMENT OPPORTUNITIES

### Software Engineers

**if...** a byte and a nibble don't make you think of food . . . peripheral is something other than vision . . . a system is not necessarily something you beat . . .

**and...** when you have a problem with "async" you don't call a plumber . . . a NAK is something you don't put on a shelf with a nik . . . going from half-to-full duplex doesn't mean doubling the rent . . .

**then...** you should bring your knowledge of telex/data communications and your software expertise (PDP 11/34, 11/44, MACRO or micro assembly language on 8086,68000 and Z80 based systems) to this fast-paced, hi tech non-commercial environment. Databit is the leading supplier of TDM concentrators/switching equipment for the telex marketplace and we're presently expanding into communication controllers. Forward your resume including salary history to: Manager, Professional Staffing, Databit Incorporated, 110 Ricefield Lane, Hauppauge, N.Y. 11788

An Equal Opportunity Employer m/f

## Databit INCORPORATED

For only . . .

# \$768

your recruitment ad in this 4" space will reach 290,000 qualified readers just like yourself.

To place your ad call 212-997-2556, or send your copy to the address below.

### BYTE

P.O. BOX 900, NY 10020

### WANTED: Simulation Engineers

If you are experienced in computer systems, programming, software configuration, flight simulation, avionics, tactics, EW, ECM, visual autopilot, nav/comm systems or flight aerodynamics we urge you to send us your resume in confidence. Link offers excellent salary, relocation, benefit plans and exceptional career growth potential at our upstate New York headquarters.

**Link**  
FLIGHT SIMULATION DIVISION

Send your resume to  
Steve Rowan, Dept. 8Y  
Link  
Flight Simulation Division  
Binghamton, NY 13902  
(607)772-3163  
E O Employer M F

Let  
**McGraw-Hill's**  
**Classified**  
**Ads Work**  
**For You**

# Systems Programmers

## Many things fly, maneuver and run on software at Kearfott. Including careers.

Whatever your software specialty, you have a choice of career paths at Kearfott—in operating systems...commercial applications...and scientific programming. Right now we're engaged in many of the most difficult, stimulating, and ultimately rewarding technological undertakings imaginable. And all of our dozens of on-going projects depend on strategic software advances in communications, logistics, MIS and guidance systems.

At our Data Center, one of the country's most sophisticated information services where

Kearfott's rarefied environment a very solid basis—you'll run the gamut. Accounting. Finance. Payroll. Inventory and manufacturing controls. All involve COBOL programming, CICS, MVS, IMS, and data base design and Telecommunications.

Scientific programming offers yet another challenge. Have strengths in simulation? Linear systems? Firmware for software validation? Kalman filtering or Fortran? Let us tell you about our firmware projects and resources.

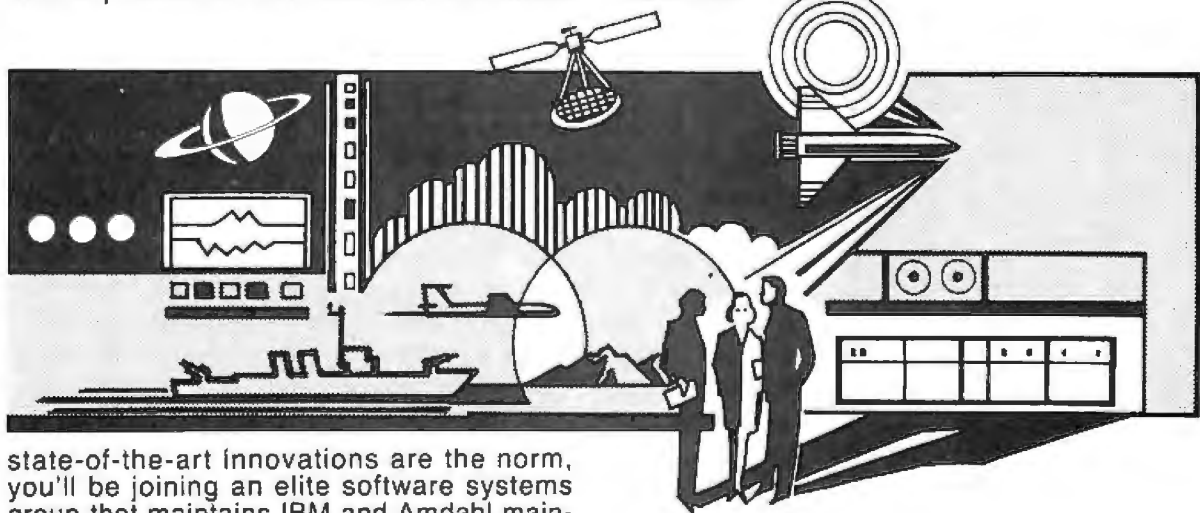

state-of-the-art innovations are the norm, you'll be joining an elite software systems group that maintains IBM and Amdahl mainframe computers with supporting software that includes MVS/SE-2, SE/A, JES 2, IMS DB/DC, CICS, TSO, WYLBUR, ACF/VTAM, ACF/NCP, SAS, information systems. This Center is tied in to all our plants via an on-line computer and provides an instant interchange of technical data. Here you'll have the opportunity to develop user-friendly software and become involved with educating company users and consulting on, and resolving, daily problems.

In MIS—the expanding sphere that has helped give

# Kearfott

a division of The SINGER Company

The path of the future for software professionals can begin with Kearfott if you have the minimum of 3 years experience in a large-scale IBM or HP 2100 MUX environment that we require.

Find out why software careers fly higher at Kearfott by sending your resume to: Carol Batte, Singer Company, Kearfott Division, 1150 McBride Avenue, Little Falls, NJ 07424.

An equal opportunity employer, m/f, who creates opportunities

## FOR TRS-80 MODEL I OR III IBM PERSONAL COMPUTER

- ★ **MORE SPEED**  
10-20 times faster than interpreted BASIC
- ★ **MORE ROOM**  
Very compact compiled code plus VIRTUAL MEMORY makes your RAM act larger. Variable number of block buffers. 31-char.-unique wordnames use only 4 bytes in header!
- ★ **MORE INSTRUCTIONS**  
Add YOUR commands to its 79-STANDARD-plus instruction set!  
Far more complete than most Forths: single & double precision, arrays, string-handling, clock, graphics (IBM low-res. gives BW and 16 color or 200 tint color display)
- ★ **MORE EASE**  
Excellent full-screen Editor, structured & modular programming  
Word search utility  
THE NOTEPAD letter writer  
Optimized for your TRS-80 or IBM with keyboard repeats, upper/lower case display driver, full ASCII!
- ★ **MORE POWER**  
Forth operating system  
Concurrent Interpreter AND Compiler  
VIRTUAL I/O for video and printer, disk and tape (10-Megabyte hard disk available)  
Full 8080 or 8086 Assembler aboard  
(Z80 Assembler also available for TRS-80)  
Intermix 35- to 80-track disk drives  
IBM can read, write and run M 3 Disks  
M 3 can read, write and run M 1 disks

# MMS FORTH

### THE PROFESSIONAL FORTH SYSTEM FOR TRS-80 & IBM PC

(Thousands of systems in use)

MMSFORTH Disk System (requires 1 disk drive 32K RAM)  
V2 0 For Radio Shack TRS-80 Model I or III \$129.95\*  
V2 1 For IBM Personal Computer (80-col screen) \$249.95\*

#### AND MMS GIVES IT PROFESSIONAL SUPPORT

Source code provided  
MMSFORTH Newsletter  
Many demo programs aboard  
MMSFORTH User Groups  
Inexpensive upgrades to latest version  
Programming staff can provide advice, modifications and custom programs. To fit YOUR needs

MMSFORTH UTILITIES DISKETTE includes FLOATING POINT MATH (BASIC ROM routines plus Complex numbers, Rectangular-Polar coordinate conversions, Degrees mode, more), a powerful CROSS-REFERENCER to list Forth words by block and line, plus (TRS-80) a full Forth-style Z80 assembler requires MMSFORTH V2.0, 1 drive & 32K RAM! \$39.95\*

FORTHCOM: communications package provides RS-232 driver, dumb terminal mode, transfer of FORTH blocks, and host mode to operate a remote FORTHCOM systems (requires MMSFORTH V2.0, 1 drive & 32K RAM) \$39.95\*

THE DATAHANDLER a very fast database management system operable by non-programmers (requires MMSFORTH V2.0, 1 drive & 32K RAM) \$59.95\*

FORTHWRITE fast, powerful Word Processor w/easy keystrokes, Help screens, manual & demo files. Full proportional w/abs., outdenting. Include other blocks, documents & keyboard inputs—ideal for form letters (requires MMSFORTH V2.0, 2 drives & 48K RAM) \$175.00\*

MMSFORTH GAMES DISKETTE real-time graphics & board games w/source code includes BREAKFORTH, CRASH-FORTH, CRYPTOQUOTE, FREEWAY (TRS-80) OHELLO & TICTACFORTH (requires MMSFORTH V2.0, 1 drive & 32K RAM) \$39.95\*

Other MMSFORTH products under development

#### FORTH BOOKS AVAILABLE

MMSFORTH USERS MANUAL - w/o Appendices \$17.50\*  
STARTING FORTH - best! \$15.95\*  
THREADED INTERPRETIVE LANGUAGES - advanced, analysis of FORTH internals \$18.95\*  
PROGRAM DESIGN & CONSTRUCTION - intro. to structured programming, good for Forth \$18.95\*  
FORTH-79 STANDARD MANUAL - official reference to 79-STANDARD word set, etc \$13.95\*  
FORTH SPECIAL ISSUE, BYTE Magazine (Aug. 1980) - A collector's item for Forth users and beginners \$4.00\*

\* ORDERING INFORMATION Software prices include manuals and require signing of a single computer license for one-person support. Describe your Hardware. Add \$2.00 SH plus \$3.00 per MMSFORTH and \$1.00 per additional book. Mass orders add 5% tax. Foreign orders add 20%. UPS COD, VISA and MC accepted, no unpaid purchase orders or refunds

Send SASE for free MMSFORTH information  
Good dealers sought

Get MMSFORTH products from your  
computer dealer or

**MILLER MICROCOMPUTER  
SERVICES (89)**

81 Lake Shore Road, Natick, MA 01760  
(617) 653-6136

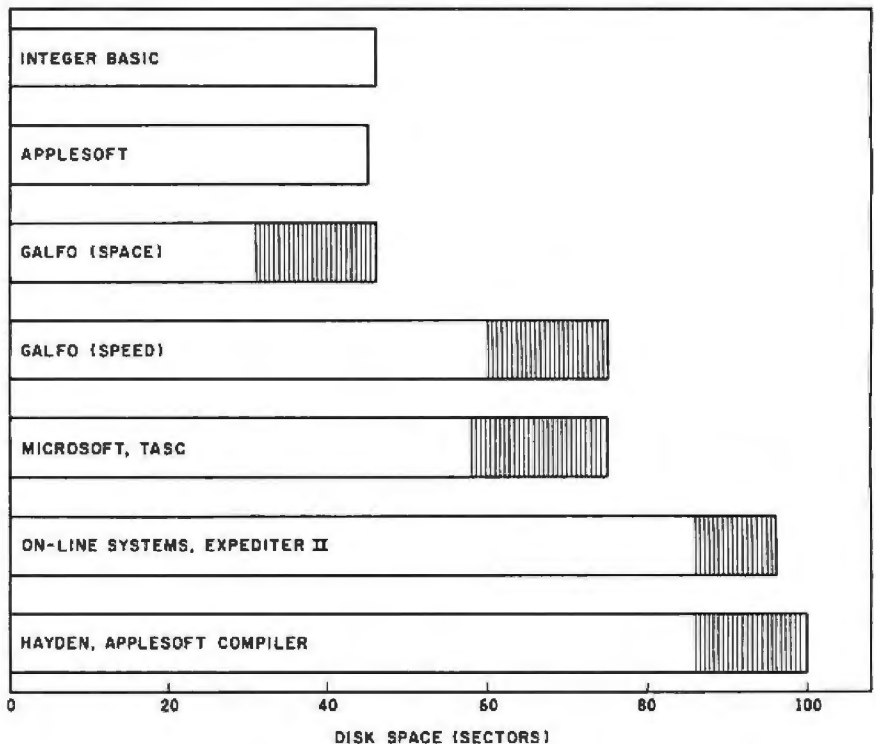

Figure 2: Comparison of disk storage requirements for a version of the Yahtzee game, using the two interpreted BASICs and four of the five compilers. Shaded segments of the bars represent the run-time libraries required by each system. Both the fastest-execution and the minimum-program-size options for Galfo Systems' Integer BASIC Compiler are shown. As described in the text, the test program was too long to be compiled by Speed Star.

tions. This problem can be reduced by using a compile-to-disk option or by using a memory-efficient segmented version of the compiler (see following section). With the segmented version, compilation speed is comparable to that of the other compilers. To run a compiled program already in memory, you simply call the starting address of the object code. The object program may be saved in binary format in the usual way, either with or without the run-time library.

### Code Expansion

In order to make an objective comparison of the memory requirements for code produced by the different compilers, we used a game similar to Yahtzee, which was programmed originally in Integer BASIC and translated directly into Applesoft. Except for small syntax differences, the two versions were essentially identical; a player could not tell which one he was using. As shown at the top of figure 2, the two versions of

the BASIC source code have nearly identical disk-storage requirements: 46 sectors for Integer BASIC and 45 sectors for Applesoft. We produced compiled versions of the program, tested each one for correct execution, and then checked the length of the object code. The results are shown in figure 2.

The clear winner of the race to produce compact code was the Integer BASIC Compiler of Galfo Systems, using its optimize-for-space option. Its object code required only 31 sectors, exclusive of the necessary 15-sector run-time library. When optimized for execution speed, the object code nearly doubled to 60 sectors (plus 15 for the library); however, the other Applesoft BASIC compilers took up equal amounts or more of memory. TASC required 75 sectors, Expediter required 96, and the Hayden compiler needed 100 sectors!

We were unable to compile Yahtzee using Speed Star. Even when using the segmented version of the compiler together with the compile-to-disk op-

# MACRO OPERATIONS FOR MICRO SYSTEMS

## Microcomputer Disk Techniques

by Paul Swanson

## Microcomputer Operating Systems

by Mark Dahmke

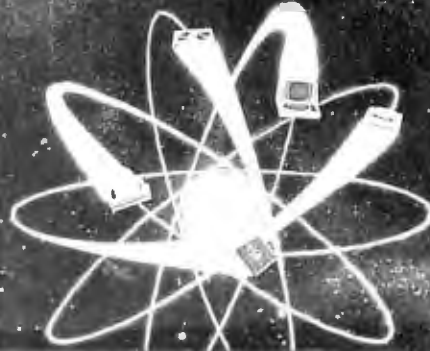

### Microcomputer Disk Techniques *by Paul Swanson*

Rarely has so much useful information been presented as clearly and logically as it is in *Microcomputer Disk Techniques*. The author shows how sophisticated methods used on larger computers may be implemented on a personal computer. Building from a basic introduction, Paul Swanson goes on to detail random-access, sequential, and key files, parameter-driven sub-routines, and, finally, the art of programming itself. This volume will help both novices and experienced computer users squeeze every bit of use out of a disk system.

Price \$15.00  
ISBN 0-07-062582-4

### Microcomputer Operating Systems *by Mark Dahmke*

A uniquely helpful volume, *Microcomputer Operating Systems* details the structures and capabilities of the operating systems that link the computer user to the hardware itself. The author explains small systems and their monitors, larger systems with terminals and disk storage, and the function of command languages. Data and memory management, multi-processing, user interference, multiuser environments, and system design are among the more specific topics included in this comprehensive guide. Two particular operating systems—CP/M and Unix—are covered in appendices.

Price \$15.95  
ISBN 0-07-033356-4

Please send \_\_\_\_\_ Microcomputer Disk Techniques \$15.00  
\_\_\_\_\_ Microcomputer Operating Systems \$15.95

Call Toll-Free 800/258-5420

Name \_\_\_\_\_  
Address \_\_\_\_\_  
City \_\_\_\_\_ State \_\_\_\_\_ Zip \_\_\_\_\_ Expiration Date \_\_\_\_\_

Check Enclosed

Bill Visa/  
MasterCard # \_\_\_\_\_

BYTE Books 70 Main Street Peterborough, N.H. 03458

Please add .75 per book to cover shipping cost.



# Sinclair Owners... Expand Yourself! I/O Capability for Your ZX-80, ZX-81.

■ **8 Port I/O Board**  
Special adapter cable mates to Sinclair edge connector.  
Feed-thru accepts Sinclair 16K memory module.  
Buffered address lines.  
Separate power supply.  
I/O command with one line of BASIC.  
8-Port bus. **I/O \$109**

■ **A/D and D/A**  
16-pin cable connects to micro developments I/O bus.  
2 channels; A/D, 0-5V input—  
D/A, 0-5V output. **AD \$99**

■ **Clock**  
16-pin ribbon cable connects to micro developments I/O bus.  
Switchable 0.1 or 1 sec resolution.  
Manual or computer control.  
Beeper. **SC \$75**

Educational documentation, applications and applications programs are provided with each board. All programs run on 1K RAM. \$5.00 handling charge on all orders.

■ **CALL TOLL FREE**  
**800-227-1617**  
operator 641  
(CA, 800-772-3545  
operator 641)

These numbers are for credit card orders only.  
For information, write us at:

Box 1140  
2000 Center Street  
Berkeley, CA 94704

**micro developments**

tion and after reducing the source code size to 38 sectors (by removing the game's instructions and many REM statements), we were confronted by out-of-memory compiler errors. Speed Star could probably handle Yahtzee if you divided the game program into two or more separately compiled segments, as described in the next section.

## Chaining and Overlays

Each of the compilers allows some kind of chaining from one program segment to another to permit very long programs to be run even though all of the object code cannot fit simultaneously into memory. Variables can be preserved, if desired, to allow access by the next chained program segment. The ease of accomplishing this task varies quite a bit among the compilers. Galfo's Integer BASIC, Hayden's Applesoft Compiler, and Southwestern Data Systems' Speed Star all allow you to disable the variable-clearing function when a new segment starts executing. However, with these compilers, all of the program's variables are, in effect, in a "global" common area, stored in the order in which they are used in the program. It is your responsibility to keep the desired equivalences straight, and this is not always an easy job. Expediter II and TASC, on the other hand, provide active REM statements that allow you to declare particular variables as "global" and others as "local." This procedure makes chaining much easier. Speed Star has a nice feature that makes it easy to call a compiled module from an interpreted Applesoft program and to pass parameters to it in a very convenient way. Unfortunately, only simple variables can be passed—not arrays—and the transfer path is a one-way street. Moving results back to the interpreted program is considerably more complicated.

In summary, by putting effort into reading the manuals and trying things out, you can accomplish almost any kind of overlaying or chaining of modules with any of these compilers, but only Expediter II and TASC make the job easy.

## Conclusions

All of the compilers perform essentially as advertised, and all provide very worthwhile improvements in execution speed. Our overall recommendations can be summarized as follows:

- Galfo Systems' Integer BASIC Compiler is the execution speed champion, by a significant margin, and also produces the most compact object code. It is our first choice for all applications where its (extended) Integer BASIC can be used.

- For more general use and for all applications in which floating-point operations are essential or desirable, our first choice is Microsoft's TASC. Its easy-to-use integer declaration makes some programs execute significantly faster than they do with any of the other Applesoft compilers. In addition, its compiled code is significantly more compact, and its user's manual is outstanding. Other less quantitative features also seem to favor TASC, including the obvious convenience of its global common declarations and its standard, unprotected disk format.

- Both Hayden's Applesoft Compiler and On-Line Systems' Expediter II each produced the fastest code in at least one of our tests, and both are very serviceable products. We fault them primarily for being somewhat less convenient to use than TASC, requiring much disk swapping on a one-drive system and (for the Hayden Compiler) requiring a system reboot before every compilation. It is worth noting that at the present list price of \$100, Expediter II is an excellent buy.

- It is a pity that Speed Star's object code is not faster; its convenience for modest-sized programs is second to none. Speed Star can reside in your Apple's memory in a more or less transparent way and can do its job on demand in just a few seconds. However, for most of our benchmark programs, its execution speed is only 2 or 3 times faster than interpreted Applesoft BASIC, as compared to 4 to 10 times for the other compilers. In some applications, the relatively poor speed ranking might be outweighed by the desirable convenience factors. ■

# PUT THE BYTE ON YOUR COMPUTER WITH 10 Mbyte STORAGE

EVOLUTIONARY ELECTRONICS INC. GIVES YOU WINCHESTER TECHNOLOGY WITH A  Shugart SA 600 HARD DISK DRIVE

10 Mbytes IN THE ROOM OF A 5 1/4 IN MINIFLOPPY™

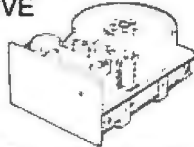

AS A FALL SPECIAL WE HAVE IN STOCK THE SA 600 FOR \$1,695 OR THE NEW LSI 801 8inch DRIVES FOR \$325 ALSO 4116 DYNAMIC MEMORY CHIPS

- KEY FEATURES**
- 10 Mbyte (unformatted) storage capacities
  - Same mounting as Shugart Minifloppy™ drives
  - Electronic damping
  - Proprietary FasFlex™ band actuator
  - 5.0 Mbits/second transfer rate
  - Same DC voltages as Shugart's Minifloppys™

WE HAVE THE FULL LINE OF SHUGART HARD AND FLOPPY DISK DRIVES CALL WEEKDAYS FROM 8 a.m. - 8 p.m.

1-503-289-3988

EVOLUTIONARY ELECTRONICS, INC. 433 N.E. LOMBARD PORTLAND, ORE 97211

© 82 SK/A

THEY SAY IT ALL... WE DO IT ALL!



## ANNOUNCING THE C86™ C COMPILER — THE COMPILER THAT SPEAKS THE LANGUAGE OF THE FUTURE!

Kernighan and Ritchie's book, *The C Programming Language*, is the key source for C. Just as fundamental is the C86™ C Compiler.

The C86™ C Compiler is especially designed for the IBM® Personal, IBM® Display Writer, CP/M-86® and MS-DOS®

For further information on the C programming language and the C86™ C Compiler, please contact:



Computer Innovations, Inc.  
75 Pine Street  
Lincroft, New Jersey 07738  
Telephone: (201) 530-0895

C86 is a trademark of Computer Innovations, Inc. CP/M 86 is a trademark of Digital Research, Inc. and MS-DOS is a registered trademark of International Business Machines, Inc.

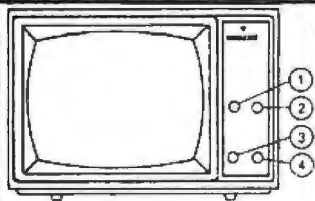

1. CONTRAST
2. POWER-BRIGHT
3. V-HOLD
4. H-HOLD

**VIDEO 100**  
12" Black & White MONITOR  
**\$89.50**  
by AMDEK

### Fourth Dimension Systems FLOPPY DISK DRIVE FOR APPLE® COMP.

The unit features a track zero micro-switch and read/write electronics DOS 3.2.1., DOS 3.3, PASCAL or CP/M.  
**\$329.95**

**DISKETTES**  
5 1/4" BULK "OEM" PACK FOR YOUR APPLE  
**\$149**  
Box of 100

### BROAD BAND MICROWAVE RECEIVER SYSTEM 1.8GHZ to 2.4 GHZ

only **\$295.00**

- RANGE Line of sight to 250 miles.  
SCOPE Will receive within the frequency band from satellites, primary microwave stations, and repeater microwave booster stations  
CONTENTS: Packaged in 19"x19"x4 1/2" corrugated carton complete with
- 24" Dish
  - Feed-Horn Receiver
  - Mounting Bracket
  - Mounting Clamp
  - Instructions
  - 300 Ohm to 75 Ohm Adapter
  - 750 Ohm to 300 Ohm Adapter
  - 60 Feet Coax Cable with Connectors
  - 3 Feet Coax Cable with Connectors

### VISION-80® 80x24 Video Display Card **\$269**

Vista Computer Company's new Vision-80 board is a sophisticated yet easy to use video display card for the Apple™ computer.

**SUPER BUY!**  
16K RAM EXPANSION CARD For Your APPLE®  
LANGUAGE TRANSPARENT ALL NINE RAMS INSTALLED!  
**\$79.95**



TERMS OF SALE: Cash, checks, credit cards, C.O.D. Calif. residents add 6% sales tax.

"HAVE YOU KISSED YOUR COMPUTER LATELY?"  
**Components Express, Inc.**

1380 E. Edinger • Santa Ana, Calif. 92705 • 714/558-3972 TWX 910-595-1565



# Digital Troubleshooting with Signature Analysis

*A look inside Hewlett-Packard's HP-5004A.*

Steven C. Piubeni  
83 Beaumont St.  
Springfield, MA 01108

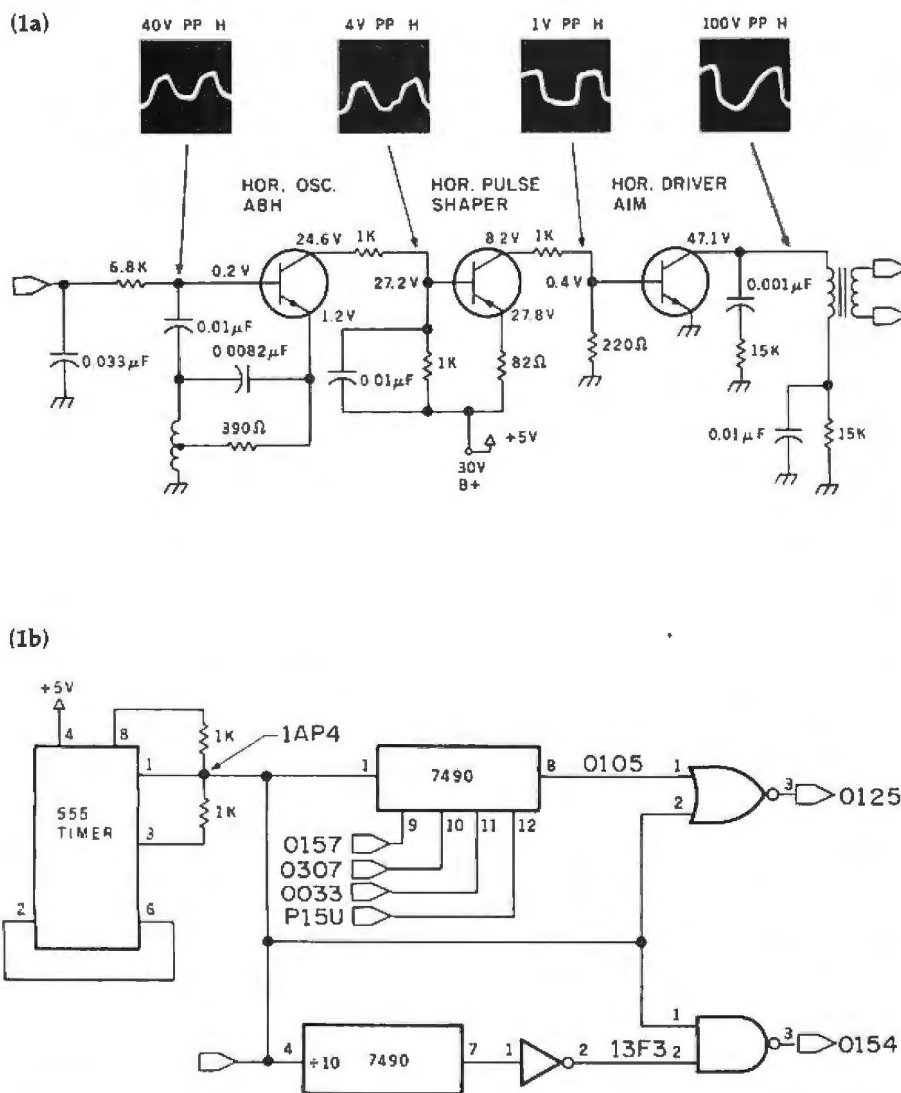

In the earlier days of electronics, signal tracing was the most common method of troubleshooting analog circuits. Most of the schematics had pictures of the expected waveforms at various test points (see figure 1). This allowed a technician with limited exposure to the product to recognize a faulty signal and repair the problem quickly. With the birth of digital electronics, however, came the complex data streams associated with bus-oriented computers. The complexity of these waveforms (often it is the timing relationship between a number of signals that is important) makes it impossible to give the inexperienced technician a visual indication of what the signals are supposed to look like.

Because of these complex circuits, most repairs made in the field have involved "board swapping." This is an expensive method of troubleshooting systems because a large inventory of boards must be kept on hand, and shipping them back to the manufacturer drives up the cost and also increases repair time.

The Hewlett-Packard HP-5004A Signature Analyzer offers a solution to all the problems discussed above. It allows the manufacturer to revert back to the simple yet efficient troubleshooting method of signal tracing. The analyzer looks at the data stream and displays a 4-bit hexadecimal signature (see figure 1b).

A signature is used to verify that



# Rave reviews



Getting them from the boss may be the best reason to switch to Opus.

Buying products that perform well is one of the yardsticks by which your own performance is measured. So we make sure you take center stage as soon as we get in on the act. For starters, we guarantee Opus performance. As well as 48-hour delivery turnaround time. Call 800/321-9330, or write to Computer Resources, Inc., 4650 West 160th Street, Cleveland, OH 44135.

## OPUS®

Quality Flexible Diskettes, Single-Disk Cartridges, Multi-Level Disk Packs, and Magnetic Tape.



### Stackworks Forth Means...

**Fast Development** As fast as compiled Fortran, as easy to use as interactive Basic. A complete approach to micro systems software development.

**Fast Debugging** A full, extendable interpreter-compiler with immediate testing capability. Ideal for robotics, process control, hardware development, videogame design.

**More than a Language** Simple, self-contained, stack oriented with compact production code, high speed, high level coding, on-the-spot debugging, in-line assembly code capability.

### Stackworks Forth Version 2.0

**\$80.88** IBM-PC DOS or CP/M-86. Complete software development package includes file editor, debugger, tutorial.

**Z80** Systems with full CP/M I/O compatibility from \$45.00.

**stack  
works**

1414 E University Box 1596 Bloomington IN 47402  
800/457-4544 812/336-1600  
MasterCard Visa Amex

## MICRO-SCI HAS THREE WAYS TO GROW A BETTER APPLE\* COST, CAPACITY, COMPATIBILITY

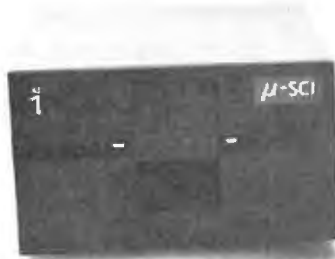

Micro-Sci has three disk drives and two controllers so you can configure your Apple II™ or Apple II Plus™ system to fit your individual budget and performance requirements.

**A2**—The new A2 is the price/compatibility substitute for the Disk II,™ intended as the second drive on an existing controller, or as a full A2 subsystem. The A2 drive or A2 subsystem is an ideal choice when the drives will be primarily used for prepackaged software programs.

The A2 comes with a unique new controller that also offers jumper selectable DOS 3.2 or 3.3. This controller supports any combination of A2s or Disk IIs, you have complete flexibility.

**A40**—The A40 is a price/performance alternative to the Disk II. With 40 tracks, you



get an additional 20K bytes, and faster track-to-track access. The A40 is intended for use in dedicated DOS, CP/M and Pascal applications, and as a companion drive for the A70. The A40 is Micro-Sci's most cost-effective disk subsystem for the Apple IIs.

**A70**—The A70 is the price/capacity Apple alternative. At over a quarter million bytes per drive, the A70 has the capacity of two Disk IIs or an eight-inch floppy, but costs only slightly more than a single Disk II. One A70 supports a DOS file as large as 270K, a CP/M file up to 254K, and 560 blocks in Pascal.

**Micro-Sci's Controllers**—The A40 and A70 share a common controller. Mix A40s and A70s in any fashion, one A40 with one A70.



two A40s or two A70s— all on the same controller.

You can have a Disk II or A2 controller with Disk II or A2 drives and still add an A40 or A70 subsystem. That's full system-level compatibility.

Versatility, reliability, capability are assured. Whatever your need, DOS 3.2, 3.3, Pascal, CP/M prepackaged software, Micro-Sci has the drive. All Micro-Sci products are backed by a full 120-day warranty (parts and labor).

Our complete line of Apple compatible products makes us the dealer's choice. We're always looking for good dealers.

International dealer inquiries:  
International Markets Co  
Telex: 277782-ROBY UR

TM, Registered Trademarks of Apple Computers, Cupertino, California

**μ-SCI**  
MICRO-SCI

Micro-Sci is a Division of Standun Controls, Inc. • 2158 South Hathaway Street • Santa Ana, California 92705 • (714) 662-2801

the data stream is correct. For example, if a signature at a particular point in a circuit is known to be 12PU; and if when a malfunctioning circuit board is probed, the signature at that point reads 3256, the problem with that board lies somewhere in that circuit path. If, when that test point is probed, the signature reads 12PU, that circuit is correct, and the problem lies somewhere else.

### Hewlett-Packard's Analyzer

The HP-5004A Signature Analyzer

weighs 5.5 lbs. The case is constructed of white "high-impact" plastic and has a 4-digit nonstandard hexadecimal display. A pouch on the top of the case is used for storing the *signal pod* and the *data probe*. The hexadecimal display's character set is: 0, 1, 2, 3, 4, 5, 6, 7, 8, 9, A, C, F, H, P, U. Hewlett-Packard claims this nonstandard hexadecimal character set is used to provide clarity between characters. I see it, however, as a cost-reducing measure because 7-segment displays are less expensive than true

hexadecimal displays. The display provided is adequate and, I must admit, the approach is clever.

The signal pod is made up of four wires with special "terminal-grabbing" connectors. Each wire is color coded for easy identification. The four pod leads hook onto the unit being tested. These leads carry the signals Start, Stop, Clock, and Ground. Start and Stop determine the period for which the signature is to be taken. Clock strobes the data into the analyzer synchronously. Ground provides a reference between the analyzer and the unit being tested. The analyzer uses a single hand-held data probe to obtain the signatures. Since the probe contains an LED (light-emitting diode), it can double as a logic probe.

The front panel of the analyzer has six push-button switches: Line, Start, Stop, Clock, Hold, and Self Test. Line is used to turn the analyzer on or off. The Start, Stop, and Clock switches set up triggering on either rising or falling edges. Pressing the Hold switch causes the analyzer to sample only the first available signature. This is similar to using an oscilloscope in the single-sweep mode. Self Test is used to determine if the analyzer is functioning properly.

### The Construction of a Signature

Signature analysis provides no diagnostic information; it is simply a comparison method of troubleshooting. Two popular theories concern implementing signature analysis. One is *transition counting*; the other is *pseudorandom-number generation*. Both methods require a Start, Stop, and Clock for proper control of the signature. (Clock is required to strobe the data stream into the counting circuitry in a synchronous fashion.)

In transition counting, a counter is initialized with a count of 0. The count will be incremented by 1 every time the Clock signal occurs *and* the data bit present on the probe differs from the data bit present during the previous Clock signal. Looking at how transition counting works, we see a situation in which a count could be ambiguous: when a string of 3 bits has complementary values on each

**We'll take  
a hard look  
at your  
software**

We're Entex.

A company that markets on an international scale.

A leader in electronic games.

And looking for software.

All kinds of software.

Games, entertainment, finance, education, anything.

As long as it's good—and marketable.

The rewards can be highly beneficial.

Sound interesting?

Then call for a product submittal form.

**213/637-6174. Ask for Ms. Ann Ruitt.**

Or write Entex Industries, Inc., 303 W. Artesia Blvd., Compton, CA 90220. Attn: Marketing.





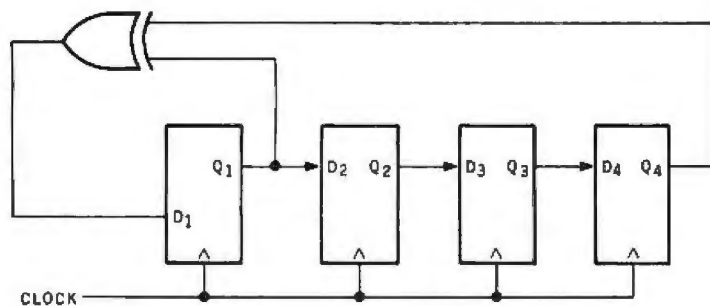

**Figure 2:** Model pseudorandom binary-number generator. This circuit produces the sequence of binary numbers shown in table 1, with just a simple shift register and an Exclusive OR gate.

Initial count→	Q1*	Q2	Q3*	Q4	D1 = Q1 + Q4
T0	1	0	0	0	1
T1	1	1	0	0	1
T2	1	1	1	0	1
T3	1	1	1	1	0
T4	0	1	1	1	1
T5	1	0	1	1	0
T6	0	1	0	1	1
T7	1	0	1	0	1
T8	1	1	0	1	0
T9	0	1	1	0	0
T10	0	0	1	1	1
T11	1	0	0	1	0
T12	0	1	0	0	0
T13	0	0	1	0	0
T14	0	0	0	1	1
Pattern repeats→	T15	1	0	0	1

\*Feedback taps

**Table 1:** The states of the various bits of the shift register in figure 2.

end. For example, let's compare the counts produced by the binary bit-stream sequences 001 and 011.

As previously mentioned, the count will be incremented every time the previous bit differs from the present bit. Let's assume that the sequences are synchronized with the clock. The analyzer looks at the first bit of sequence 001 and compares it to the second. Because the first 2 bits are different, the count is incremented. The analyzer will then proceed to look at the second and third bits. Since they are identical, the count will remain at 1. Now let's look at sequence 011: the analyzer looks at the first and second bits. Since they are identical, the count will remain at 0. The analyzer will now look at the second and third bits and see that they are complementary. The count will

be incremented to 1. Notice that the two sequences produced the same signature. This method leads to ambiguity, and thus should not be implemented.

### Pseudorandom Binary Sequences

Robert Frohwerk (who did the design work for Hewlett-Packard on signature analysis) came up with an alternate choice called PRBS (pseudorandom binary sequences). Although the term sounds quite complicated, it is relatively easy to understand with the aid of figure 2.

Only two different types of components are required to implement PRBS signature analysis: the Exclusive OR gate and the D-type flip-flop. The Exclusive OR gate acts as a modulo-2 adder; the flip-flop performs the function of a shift register

when hooked in series with other D-type flip-flops.

By taking the outputs of different flip-flops, Exclusive ORing them together, and feeding the result back into the shift register, we produce a pseudorandom sequence. Initially, the shift register must be preset to 0001. This enables the PRBS generator to run freely. If the count were set to 0000, there would be no feedback, and the generator would not run.

In table 1, we see the output of a PRBS generator in free-running mode. After one clock cycle, the first bit is loaded into the shift register. If the outputs of each flip-flop were visible, we would see (in order) 1000. On the next clock cycle, the output of the first flip-flop will be passed along to the second. The input of the first flip-flop will now be determined by the output of the Exclusive OR gate.

Checking table 1, we see that at T1 the output of bit 1 is 1 and the output of bit 4 is 0. Therefore, the feedback loop will load a 1 into the first flip-flop of the shift register. After the sixteenth clock pulse (T15), the pattern repeats, providing us with a cyclic counter capable of compressing large data streams and providing an accurate signature.

### How Is It Really Done?

Now that we have looked at a model PRBS generator, let's discuss the PRBS generator circuit used in the HP-5004A. The HP-5004A uses a 16-bit shift register. This allows for plenty of accuracy, which will be discussed shortly. The four feedback taps are from bits 7, 9, 12, and 16 of the shift register. (Most microprocessors and other digital equipment use data related by powers of 2. By spacing the taps unevenly, we guarantee picking up the maximum number of errors. See table 2.)

When first looking at the circuit detailed by Hewlett-Packard (see figure 3), it would appear as though the four feedback taps are fed into a four-input Exclusive OR gate. After checking several data manuals published by Texas Instruments, Signetics, National Semiconductor, and Fairchild, I could not find such an integrated circuit. I constructed an

# BDOS ERROR ON B:BAD SECTOR

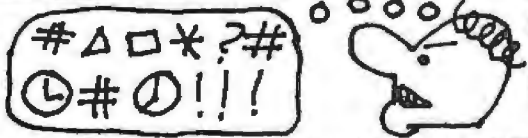

Before disk errors ruin your work again order BADLIM.

- BADLIM assures the reliability of your CP/M computer.
- You can use your disks 10 times longer without losing your data AND your time.
- BADLIM checks thoroughly your disk marking all the blocks which have defective sectors. The operating system will know that those sectors should be skipped.
- BADLIM is the only program that gives protection for soft and hard errors.
- The first time BADLIM will list which files in your disk are on bad sectors, so you can take action to correct it.
- But thereafter the bad areas in your disk will be automatically by-passed.
- For CP/M 1.4 single density and for CP/M 2.xx of any format and density. It is a must for Winchester as the media cannot be replaced.

BADLIM cost only \$73. Whatever the reason you have to use a computer you need BADLIM. Contact your dealer or call us today

BLAT R&D Corp., 8016 188th. St SW, Edmonds WA 98020. Phone: (206) 771-1408

DEALER INQUIRIES INVITED. **BADLIM**

# POWER-LINE FILTERS

These filters protect any sensitive electronic equipment from power line transient damage and radio frequency interference. Both models offer surge suppression for power line "spikes", RF interference is suppressed using both inductive and capacitive components. Ideal for computers, test equipment, or TV.



LF2—A duplex outlet, 120V, 8 amps . . . \$39.95

LF6— Three separately filtered duplex outlets, 120V, total fused capacity 15 amps, power switch and indicator lamp . . . \$69.95

Add \$2.50 shipping and handling per order. Send check with order and provide street address for UPS shipment. Ohio residents add Sales Tax. Charge card buyers may call toll-free:



**1-800-543-5612**

In Ohio, or for information, call: **1-513-866-2421**



## R. L. DRAKE COMPANY

540 Richard Street, Miamisburg, Ohio 45342

INSTITUTIONAL AND DEALER INQUIRIES INVITED

# BUILD YOUR COMPUTER BREADBOARDS & INTERFACES FASTER AND EASIER WITH NEW VECTOR PLUGBOARDS

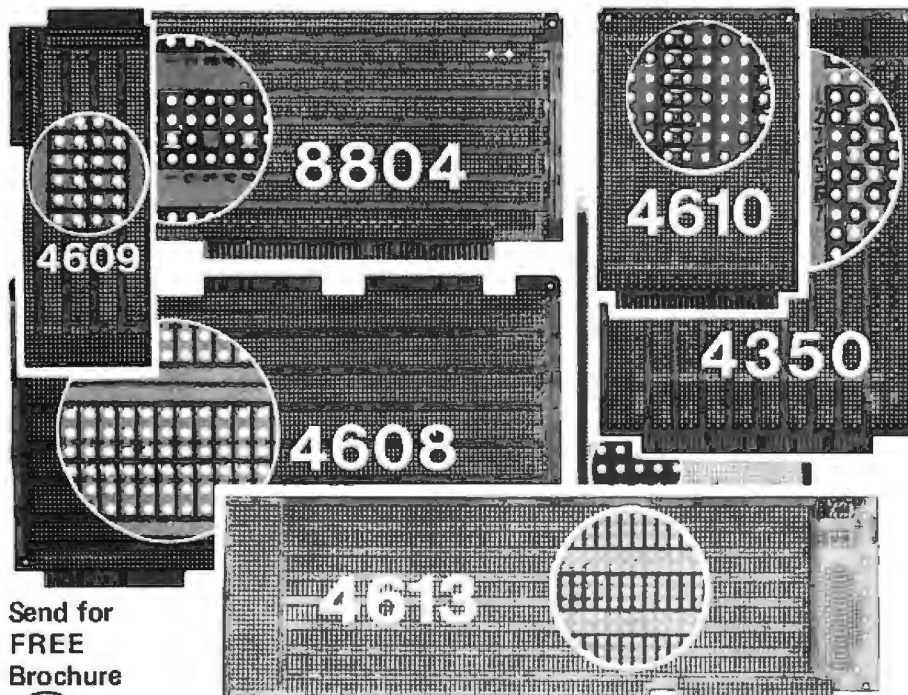

Send for  
**FREE**  
Brochure



VECTOR ELECTRONIC COMPANY, Inc., 12460 Gladstone Ave., P.O. Box 4336, Sylmar, CA 91342-0336; (213) 365-9661 748207

Circle on inquiry card: 472 for 4613, 473 for 4610, 474 for 4608, 475 for 8804, 476 for 4609, 477 for 4611, and 478 for 4607 and 4350.

New 4613 series — for IBM Personal Computer. Three models available.

4610 series — for STD-BUS-WW, solderable and unpatterned models.

4608 series — for Intel/National SBC/BLC 80-WW solderable, or unpatterned.

8804 series — for S-100. Five models available.

4607 — for DEC LSI-11/PDP8-11, Heath-11.

4609 — for Apple II, Super-Kim, Pet Commodore with Expandamem.

4350 — for TI 980 Computer.

4611 series — for Motorola Exorciser,™ Rockwell AIM65 expansion.

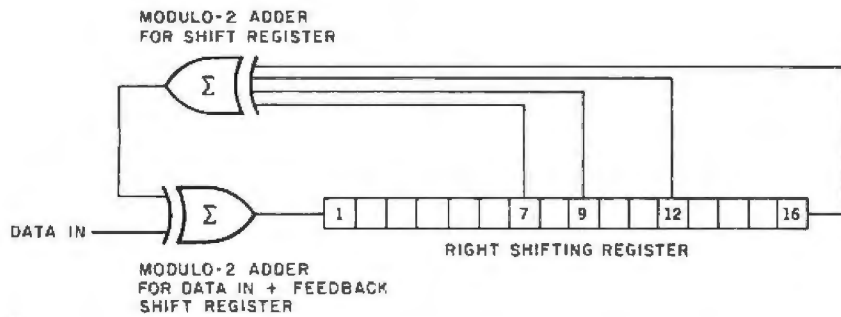
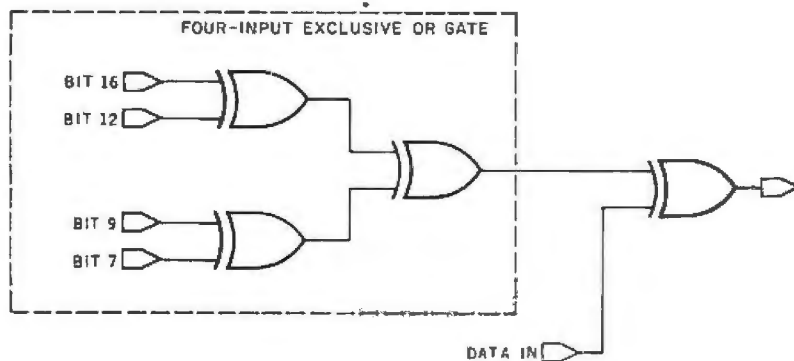

Figure 3: Pseudorandom-number generator as used by Hewlett-Packard in its HP-5004A Signature Analyzer. The four-input Exclusive OR gate is made from a parity generation/checking device.

(4a)



(4b)

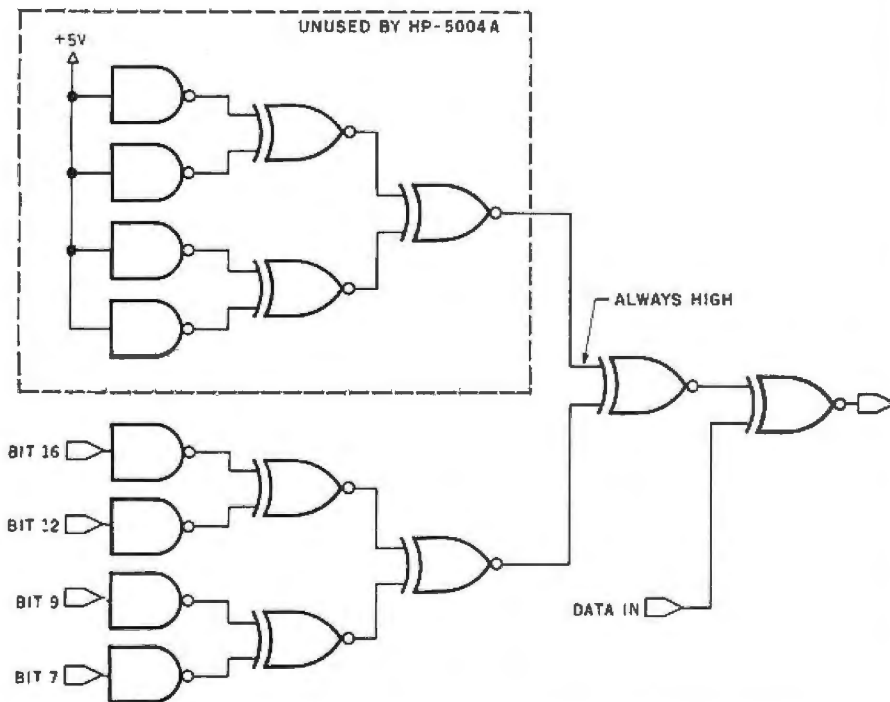

Figure 4: Two methods of using a four-input Exclusive OR device. Figure 4a is the equivalent of figure 3, with the internal architecture displayed. Figure 4b shows the insides of the 82562 device used by Hewlett-Packard.

equivalent circuit employing a 7486 two-input Exclusive OR gate (see figure 4a).

When I checked the actual HP-5004A circuit board, I found that an 82562 parity generator/checker was being used as a four-input Exclusive OR gate and a two-input Exclusive OR gate. In figure 4b, I show the architecture for implementing the four-input Exclusive OR gate. An advantage to using this device is that the data can also be Exclusive ORed with the modulo-2 sum of the feedback taps from the shift register. Although you may find the use of one integrated circuit as opposed to another insignificant, it is interesting to note the engineering involved in obtaining the maximum performance at the minimum cost.

Because of the unique design of the circuit, the PRBS generator will always pick up a single-bit error. To calculate the chance of the generator missing multiple bits, the following equation can be used:

$$\text{Prob} = (1/2)^n$$

Prob is the probability of an error not being detected;  $n$  is the number of bits in the PRBS generator. For the HP-5004A, with 16 bits arranged in a PRBS design, the error rate is 16 ppm (parts per million), or 1 in 65,535. This is certainly acceptable for most applications.

### Analyzing Signatures

Up to now, we have discussed the need for signature analysis, what a signature actually is, and the different methods of obtaining a signature. We will now briefly focus on using signature analysis, an overview of the HP-5004A, and how signature analysis will affect the microcomputer market.

The signature analyzer has very little hardware and software. Therefore, it depends upon diagnostic test programs running on the system being tested. These programs are usually stored in ROM (read-only memory). The diagnostic program toggles all the address lines, data lines, I/O (input/output) ports, and different enable lines. With the test

## Look what YOU can do with Badge-A-Minit

Create enthusiasm, build morale, reinforce training, identify employees and visitors, enforce security, promote special events, stimulate sales, etc. In just a matter of minutes using the simple, compact Badge-A-Minit system you and your staff can make professional pin-back badges to carry any slogan, design or message in an exciting, highly visible way for instant reaction!

**Starter Kit Includes Everything You need only \$19.95**

**FREE!** Colorful 64-page catalog and idea book you can use for imaginative classroom instruction.

**HOW AT ONLY \$19.95** the lowest price available by far for a complete badge-making system... our **Complete Starter Kit** contains sturdy Lexan die press, color-coded dies, quality pin-back badge parts, simple but thorough instructions... everything you need to get started.



Badge-A-Minit, Ltd. Dept. BY 9/82  
Box 618 Civic Industrial Park, LaSalle, IL 61301

- Please send me the Badge-A-Minit Starter Kit for only \$19.95 plus \$1.75 shipping fee. (If I live in Illinois, I'm including \$1.00 sales tax.)
  - My check or money order is enclosed.
  - Use my charge card checked below.
    - VISA  MasterCard  American Express  Diners Club
  - Credit Card No. \_\_\_\_\_ Exp. Date \_\_\_\_\_
  - Interbank No. \_\_\_\_\_ (VISA and MasterCard only)
  - Send me the FREE 64-page, full color illustrated Badge-A-Minit catalog.
- Name \_\_\_\_\_ Address \_\_\_\_\_  
City \_\_\_\_\_ State \_\_\_\_\_ Zip \_\_\_\_\_

**UNCONDITIONAL MONEY-BACK GUARANTEE**

# START YOUR OWN COMPUTER CO.

**HOW TO START YOUR OWN SYSTEMS HOUSE** \$36.  
7th edition, November 1981

Written by the founder of a successful systems house, this fact-filled 220-page manual covers virtually all aspects of starting and operating a small systems company. It is abundant with useful, real-life samples, contracts, proposals, agreements and a complete business plan are included in full, and may be used immediately by the reader. Proven, field-tested solutions to the many problems facing small turnkey vendors are presented.

**HOW TO BECOME A SUCCESSFUL COMPUTER CONSULTANT** \$28.  
by Leslie Nelson, 4th revised edition, December 1981

Independent consultants are becoming a vitally important factor in the micro-computer field, filling the gap between the computer vendors and commercial/industrial users. The rewards of the consultant can be high, freedom, more satisfying work and doubled or tripled income. This manual provides comprehensive background information and step-by-step directions for those interested to explore this lucrative field.

**FREE-LANCE SOFTWARE MARKETING** \$30.  
by B. J. Korites, 3rd edition, June 1980

Writing and selling computer programs as an independent is a business where you can get started quickly, with little capital investment you can do it full time or part time the potential profits are almost limitless. This best-seller by Dr. Korites explains how to do it.

**HOW TO START YOUR OWN WORD PROCESSING SERVICE** \$39.50  
by Leslie Nelson, May 1982

Turn a small investment into a steady money making business that adds \$10,000, \$50,000 or \$100,000 to your income. Detailed start-up, marketing and operations plans are included.

Send check, money order, VISA, Master Charge or American Express and exp. date. Publisher pays 4th class shipping. Add \$1.00 per book for UPS shipping (USA only). NJ residents add 5% sales tax. For faster shipment on credit card orders call (201) 783-6940.

**ESSEX PUBLISHING CO.** Dept. 2  
285 Bloomfield Avenue • Caldwell, N.J. 07006

## PRODUCTS FOR YOUR RADIO SHACK

**NEW!**

# COLOR COMPUTER

## MACRO-80C

## YOU NEED COLOR FORTH!!

The Micro Works is pleased to announce the release of its disk-based editor, macro assembler and monitor, written for Color Computer by Andy Phelps. THIS IS IT — The ultimate programming tool!

The powerful 2-pass macro assembler features conditional assembly, local labels, include files and cross referenced symbol tables. MACRO-80C supports the complete Motorola 6809 instruction set in standard source format. There are no changes, constraints or shortcuts in the source language definition. Incorporating all of the features of our Rompack-based assembler (SDS80C), MACRO-80C contains many more useful instructions and pseudo-ops which aid the programmer and add power and flexibility.

The screen-oriented text editor is designed for efficient and easy editing of assembly language programs. The "Help Key" feature makes it simple and fun to learn to use the editor. As the editor requires no line numbers, you can use the arrow keys to position the cursor anywhere in the file. MACRO-80C allows global changes and moving/copying blocks of text. You can edit lines of assembly source which are longer than 32 characters.

DCBUG is a machine language monitor which allows examining and altering of memory, setting break points, etc.

The editor, assembler and monitor — as well as sample programs — come on one Radio Shack compatible disk. Extensive documentation included. MACRO-80C Price: \$99.95

**SDS80C** — Our famous editor, assembler and monitor in Rompack. Complete manual included. Price: \$89.95

**PARALLEL PRINTER INTERFACE** — Serial to parallel converter allows use of all standard parallel printers. You supply printer cable. **PI80C** Price: \$69.95

**MICROTEXT** — Get printouts while using your modem! Also download to cassette. General purpose terminal Rompack. Price: \$59.95

Why?

- Forth is faster to program in than Basic
- Forth is easier to learn than Assembly Language
- Forth executes in less time than Basic

Forth is a highly interactive language like Basic, with structure like Pascal and execution speed close to that of Assembly Language. The Micro Works Color Forth is a Rompack containing everything you need to run Forth on your Color Computer.

Color Forth consists of the standard FORTH Interest Group (FIG) implementation of the language plus most of FORTH-79. It has a super screen editor with split screen display. Mass storage is on cassette. Color Forth also contains a decompiler and other aids for learning the inner workings of this fascinating language. It will run on 4K, 16K, and 32K computers. Color Forth contains 10K of ROM, leaving your RAM for your programs! There are simple words to effectively use the Hi-Res Color Computer graphics, joysticks, and sound. The 112-page manual includes a glossary of the system-specific words, a full standard FIG glossary and complete source listing. **COLOR FORTH ... THE BEST!** From the leader in Forth, Talbot Microsystems. Price: \$109.95

## GAMES

**Star Blaster** — Blast your way through an asteroid field in this action-packed Hi-Res graphics game. Available in ROMPACK; requires 16K. Price: \$39.95

**Pac Attack** — Try your hand at this challenging game by Computerware, with fantastic graphics, sound and action! Cassette requires 16K. Price: \$24.95

**Barsark** — Have fun zapping robots with this Hi-Res game by Mark Data Products. Cassette requires 16K. Price: \$24.95

**Adventure** — *Black Sanctum* and *Calixto Island* by Mark Data Products. Each cassette requires 16K. Price: \$19.95 each.

**Cave Hunter** — Experience vivid colors, bizarre sounds and eerie creatures in hot pursuit as you wind your way through a cave maze in search of gold treasures. This exciting Hi-Res game by Mark Data Products requires 16K for cassette version. Price: \$24.95

**THE MICRO WORKS**

Also available: Machine language Monitor ★ 2-pass Disassembler ★ Books ★ Memory Upgrade Kits ★ Parts and Services ★ Call or write for information

California Residents add 6% Tax  
**Master Charge/Visa and COD Accepted**

P.O. BOX 1110 DEL MAR, CA 92014

714-942-2400

SEPT. SPECIAL SALE ON PREPAID ORDERS  
(CHARGE CARDS, C.O.D OR P.O.'S NOT AVAILABLE)  
MUST MENTION AD FOR SPECIAL PRICES  
WAMECO CRT - 1 WITH MIKOS PARTS.

KIT ..... \$199.95  
WAMECO MEM - 3 WITH MIKOS PARTS LESS RAM.  
KIT ..... \$85.95



CALIFORNIA COMPUTER SYSTEMS

**\$100**

2032 32K STATIC RAM A & T 200NSEC \$468.00  
2065 64K DYNAMIC RAM A & T \$351.00  
2200 S-100 MAIN FRAM A & T \$500.00  
2422A FLOPPY DISC WITH CP/M 2.2\* \$372.50  
2810A Z80 CPU A & T \$281.25  
2710A 4 SERIAL 1/0 A & T \$291.95  
2501A 12 SLOT MOTHER BOARD ..... \$180.00  
2720A 4 PARALLEL A & T \$214.95  
PROTO BOARDS WW \$39.95

**APPLE PRODUCTS**

7114A 12K ROM/PROM \$99.95  
7424A CALENDAR/CLOCK \$106.95  
7440A PROGRAMMABLE TIMER \$106.95  
7470A A TO D CONVERTER \$105.95  
7490A GPIB (IE 488) INTERFACE \$182.00  
7710A ASYNC SERIAL \$125.95  
7712A SYNC SERIAL \$148.50  
7720A PARALLEL STANDARD \$105.00  
7720B PARALLEL CENTRONICS \$105.00  
7811B ARITHMETIC PROCESSOR W/DISC \$325.00  
7811C ARITHMETIC PROCESSOR W/ROM \$325.00  
7520A EXTENDER ..... \$23.50  
7300A APPLE CLIP ..... \$8.00



MICROCOMPUTER PRODUCTS

**\$100 PRODUCTS**

CB-2 280 PROCESSOR BOARD  
KIT \$198.95 A & T \$269.95  
VBIC 64 x 16 VIDEO PCBD \$32.95  
KIT \$153.95 A & T \$199.95  
VB3 80 CHARACTER VIDEO 4MHZ  
KIT \$345.95 A & T \$425.95  
ID4 2 PARALLEL 2 SERIAL PCBD \$32.95  
KIT \$160.95 A & T \$199.95  
PB-1 2708. 2716 PROGRAMMER BOARD  
KIT \$140.95 A & T \$189.95

**APPLE PRODUCTS**

A10 - II SERIAL/PARALLEL INTERFACE  
A & T ..... \$178.00  
AS10 SERIAL I/O  
A & T ..... \$115.95  
AP10 PARALLEL I/O W/O CABLES  
A & T ..... \$87.95



WAMECO INC.

**BOARDS WITH MIKOS PARTS**

MEM-3 32K STATIC RAM PCBD \$36.95  
KIT LESS RAM \$95.95 A & T \$135.95  
CPU-2 Z80 PROCESSOR PCBD \$32.95  
KIT LESS ROM \$109.95 A & T \$149.95  
CRT-1 36 OR 24 x 80 VIDEO BOARD, PCBD .. \$38.95  
KIT ..... \$249.95, A & T, ..... \$299.95  
FPB-1 FRONT PANEL PCBD \$48.50  
KIT \$144.95, A & T \$184.95  
MEM-4 65K RAM/ROM BOARD, PCBD ..... \$38.95  
KIT LESS MEMORY, ..\$99.95, A & T LESS MEMORY \$129.95

**MIKOS**

MONDAY-FRIDAY, 8 00 TO 12 00, 1 00 TO 5 30  
THURSDAYS, 8 00 TO 9 00 P M  
(415) 728-9121

P.O. BOX 955 • EL GRANADA, CA 94018  
PLEASE SEND FOR IC, XISTOR AND COMPUTER PARTS LIST  
VISA or MASTERCARD. Send account number, interbank  
number, expiration date and sign your order. Approx. postage will  
be added. Orders with check or money order will be sent post paid  
in U.S. If you are not a regular customer, please use charge,  
cashier's check or postal money order. Otherwise there will be a  
two-week delay for checks to clear. Calif. residents add 6 5% tax.  
Money back 30-day guarantee. We cannot accept returned IC's  
that have been soldered to. Prices subject to change without  
notice. \$20.00 minimum order. \$2.00 service charge on orders less than  
\$20.00.

Bits Clock	1	2	3	4	5	6	7*	8	9*	10	11	12*	13	14	15	16*
T20	0	0	1	0	1	0	0	1	0	1	0	1	1	0	1	0
T19	0	1	0	1	0	0	1	0	1	0	1	1	0	1	0	0
T18	1	0	1	0	0	1	0	1	0	1	1	0	1	0	0	1
T17	0	1	0	0	1	0	1	0	1	1	0	1	0	0	1	1
T16	1	0	0	1	0	1	0	1	1	0	1	0	0	1	1	1
T15	0	0	1	0	1	0	1	1	0	1	0	0	1	1	1	0
T14	0	1	0	1	0	1	1	0	1	0	0	1	1	1	0	0
T13	1	0	1	0	1	1	0	1	0	0	1	1	1	0	0	0
T12	0	1	0	1	1	0	1	0	0	1	1	1	0	0	0	0
T11	1	0	1	1	0	1	0	0	1	1	1	0	0	0	0	0
T10	0	1	1	0	1	0	0	1	1	1	0	0	0	0	0	0
T9	1	1	0	1	0	0	1	1	1	0	0	0	0	0	0	0
T8	1	0	1	0	0	1	1	1	0	0	0	0	0	0	0	0
T7	0	1	0	0	1	1	1	0	0	0	0	0	0	0	0	0
T6	1	0	0	1	1	1	0	0	0	0	0	0	0	0	0	0
T5	0	0	1	1	1	0	0	0	0	0	0	0	0	0	0	0
T4	0	1	1	1	0	0	0	0	0	0	0	0	0	0	0	0
T3	1	1	1	0	0	0	0	0	0	0	0	0	0	0	0	0
T2	1	1	0	0	0	0	0	0	0	0	0	0	0	0	0	0
T1	1	0	0	0	0	0	0	0	0	0	0	0	0	0	0	0
T0	0	0	0	0	0	0	0	0	0	0	0	0	0	0	0	0

\*Feedback taps

Table 2: The states of selected bits of the shift register in figure 3.

program adding about 2 percent of firmware to the system, the overhead is minimal.

When a computer system is down, the technician simply plugs in a test ROM and hooks the signature-analyzer pod to the designated terminals for Start, Stop, Clock, and Ground. All that's required now is to take signatures and compare them to the schematic. Once the erroneous signature is found, the signal path is traced back to the faulty component.

Another valuable use for a signature analyzer is to test ROMs out of a system. By building a counter equal to the number of addresses in the ROM, and allowing the counter to run, it will address each location and create a data stream in which signatures could be recorded. The questionable ROM signatures could be compared to the standard signatures to see if they coincide. This approach could also be applied to random-access read/write memory, if read/write circuitry was installed.

**Conclusions**

The application of signature analysis in the microcomputer market

will become more evident because it employs a nontechnical approach to troubleshooting complex circuits. By applying this technique on the manufacturing level, an untrained individual can do the job previously held by a highly skilled technician. The use of signature analysis could also eliminate the need for multiple, replaceable boards because field diagnostics could be made down to the component level. Both of these cost-reducing measures will help bring down the already falling price of computers, thus bringing more consumers into the marketplace.

In the years ahead, we will see signature analysis seeping into the computer market, just as we have seen the microprocessor become the standard of computer circuit design. ■

**References**

1. Frohwerk, Robert A. "Signature Analysis: A New Digital Field Service Method." *Hewlett-Packard Journal*, May 1977.
2. Gordon, Gary and Hans Nadig. "Hexadecimal Signatures Identify Trouble-Spots in Microprocessor Systems." *Electronics*, March 1977.
3. *Hewlett-Packard Operating and Service Manual*, March 1977.



## SEPTEMBER SPECIALS

	OUR SPECIAL CASH PRICE
SSM PB-1 PROM Burner Kit	129.00
SSM VB-3 80 x 24 Video Kit	339.00
Morrow Designs WUNDERBUS 8 slot - A & T	89.00
Calif. Comp. Systems 64K Dynamic Ram - A & T	299.00
Mullen TB-4 Extender Card w/ probe-kit	47.00
Godbout RAM 17-64K Static Ram - A & T	449.00
Qume DT-8 DS/DD 8" disk drive	479.00
Ithaca Intersystems FDC-II Disk Controller - A & T	483.00
North Star Advantage - A & T	2679.00
S-100's Dual 8" Drive box w/P/S & Cables	349.00
Seattle Computer Products Support board - A & T	263.00
S.D. Systems PROM 100 Kit	169.00

VISIT OUR SHOWROOM - Hrs. - 9:00 A.M. - 5:30 P.M. M-F

Subject to Available Quantities • Prices Quoted Include Cash Discounts  
Shipping & Insurance Extra.

We carry products from all Major Manufacturers



## NASHUA DISKETTES LIMITED TIME OFFER

**\$1.69** FROM EACH



Every NASHUA Diskette is tested at thresholds two to three times greater than systems requirements and THEN certified to be 100% ERROR-FREE!

**5 1/4" DISKETTES** (Specify 1, 10, or 16 Sectors)  
 No. 5A—One Sided, Single Density—\$1.69  
 No. 5B—One Sided, Double Density—\$2.22  
 No. 5C—Two Sided, Double Density—\$2.59

**8" DISKETTES** (Specify 1 or 32 Sectors)  
 No. 8D—One Sided, Single Density—\$2.02  
 No. 8E—One Sided, Double Density—\$2.49  
 No. 8F—Two Sided, Double Density—\$3.33  
 Minimum quantity: 100 Diskettes

Please send me \_\_\_\_\_ of No. \_\_\_\_\_ at \_\_\_\_\_  
QUANTITY TYPE SECTOR PRICE

Name \_\_\_\_\_

Address \_\_\_\_\_

City \_\_\_\_\_ State \_\_\_\_\_ Zip \_\_\_\_\_

Sales Tax must be added in New York, Florida and California.

Send C.O.D.  Enclosed is my check

**MANCHESTER EQUIPMENT CO. INC.**  
"The Computer Supply Experts"

30 MIDLAND AVENUE ■ HICKSVILLE, NEW YORK 11801  
 (516) 433-0613 ■ (212) 564-6065

# Micro Match solves the IBM PC expansion puzzle.

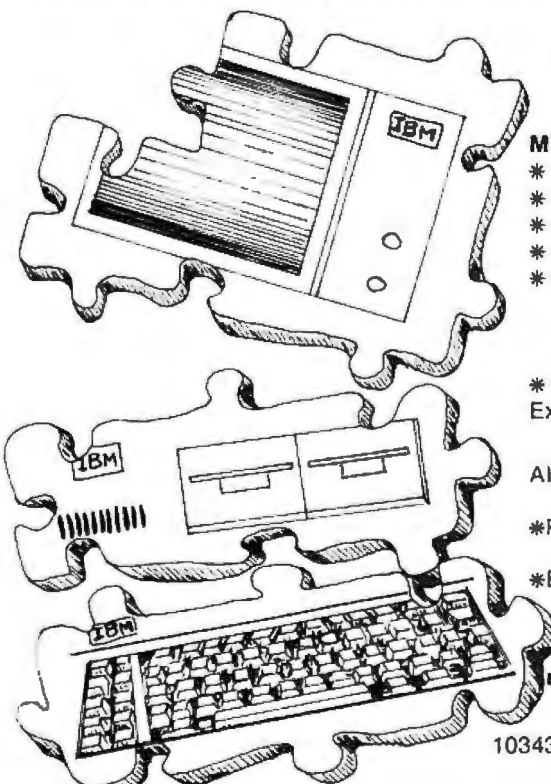

### MM64 MEMORY BOARD

- \* Expands in 64K increments
- \* Includes sockets for all RAM
- \* RAM test program included
- \* 5 year warranty
- \* Parity .... MM64-1 ( 64K) \$400.  
 MM64-2 (128K) \$510.  
 MM64-3 (192K) \$620.  
 MM64-4 (256K) \$730.
- \* 64K Expansion Kit (9 chips)  
 Expands MM64 memory ... \$108.

Also available:

- \* Prototyping Board ..... \$50.
- \* Extender Board ..... \$45.

### TANDON DISK DRIVES FOR YOUR IBM PC.

- \* Installation instructions included
- \* IBM PC compatible
- TM100-1 (Single Sided 160K byte storage) ..... \$225.
- TM100-2 (Double Sided 320K byte storage) ..... \$295.

\* Send for our free Catalog

To order: Send check or Money Order (US only). Add \$3.50 for Shipping and Handling. California residents add 6% sales tax. Master Card/VISA accepted.

**MICRO MATCH** Quality Products  
 Personal Computer

10343 Commerce Ave. Dept. B • Tujunga, CA 91042 • (213) 353-5929

# Program Your Own Text Editor

## Part 1: Avoid Complex Commands by Using Instant Updating

---

Richard Fobes  
Creative Computer Services  
POB 1327  
Corvallis, OR 97339

---

The awkwardness of using traditional text editors is a constant source of frustration for many computer users. The use of special sequences of characters to manipulate and display text just isn't natural. It would be much easier to manipulate text if an editor duplicated the advantages of a typewriter; namely, the text is always visible in its latest form and each press of a key is a complete operation. This two-part article presents such a text editor and it is a dramatic improvement over traditional text editors.

Text editing, which is nothing more than the creation and modification of textual material (such as computer programs, letters, and manuscripts), is the cornerstone of computer applications. But it is unfortunate (and ironic) that the text editor is often the most awkward program to use. Fortunately, improvements in the convenience of editing are practical and are becoming common. Such improvements increase productivity, reduce frustration, and make computers more accessible to the average person. The text editor presented here offers these advantages.

I call my text editor the Video-Display-Oriented Text Editor (VDO text editor). Part 1 of this article describes

the design and use of this editor and part 2 contains the listing of the program source code (in assembly language for Z80- and 8080-based microcomputers). The comments within the listing will allow readers to implement it on their systems. Also included in part 2 are sample I/O (input/output) routines that interface the program with the peripheral devices of the author's system.

---

**This text editor  
makes computers more  
accessible to the  
average person.**

---

### A Brief Description

The most important feature of the VDO text editor is that, in the normal editing mode, the video-display screen contains only the text. There is no need for instructions to appear on the screen because pressing a single key immediately changes the text both internally and on the screen. Although this concept is simple, its practicality is impressive. Consider

what it would be like to have 16 or 24 lines of text visible on your screen and to see the text updated *as soon as you press a key*.

In order to make this scheme practical, it must be easy to quickly repeat the editing operations any number of times. The most convenient way of doing this is to hold down the appropriate key while the editor quickly repeats the indicated operation and release the key when it has been repeated enough. To differentiate between a one-time operation and a repeated operation, a time delay is included between the first execution of the operation and the beginning of the fast repetitions. This feature (included in some computer terminals and electric typewriters) is referred to here as the *automatic repeat feature*.

The automatic repeat feature is of central importance to the use of the VDO text editor, so I will explain its operation from a user's point of view. When a key is initially pressed, the appropriate editing operation is executed. If the key is released within one second, nothing further happens. However, if the key is still depressed one second after it was first pressed, the editor automatically repeats the same operation at a fast rate—say 10 times per second. As the repetitions

**SAVE**



**TRS-80's™**  
FULL LINE  
and  
**Hewlett  
Packard**  
85, 87, 125

WE PAY SHIPPING in the 48 continental states on prepaid orders of \$100.00 or more.  
NO TAXES are collected on out-of-state shipments.  
WE ACCEPT Visa, MasterCard and American Express, or you can save additional money by paying cash.

TOLL FREE ORDER NUMBER 800/531-7466

**Pan American  
Electronics**

1117 Conway • Dept. B  
Mission, Texas 78572  
Phone 512/581-2766  
Telex Number 767339

FORT WORTH BRANCH  
2912 N. Main  
Ft. Worth, Texas 76106  
Phone 817/625-6333  
Telex Number 794836



**Hewlett-  
Packard**

85, 87, 125

TM — Trademark of Tandy Corporation

# TELEPHONE VOICE RESPONSE

The V100 interactive voice synthesizer with telephone interface is an Apple II® or IBM Personal Computer® compatible, low-cost, solution to remote data base access arrangements.

**\$39500**  
V100-A

- Direct telephone connection, auto-dial/answer
- Touch-tone® generation and detection
- Includes 300 word, LPC vocabulary
- Software for sentence/library construction
- Expandable with 1300 (\$495) high quality LPC words

For a demonstration call toll free (800) 538-7002  
In California call (408) 942-1595

**VYNET  
CORPORATION**

2405 Qume Dr., San Jose, CA 95131 (408) 942-1037



# WHAT'S ECC?

ECC (Error Correctin Code) is a polynomial derivative which is used to detect and correct errors. In simpler terms, this means that the computer will detect and automatically correct data errors sometimes generated spuriously in the equipment.

VR Data's RAM BOARD has this feature. If your system will abend or die during a data error or if you must always have the correct data for your functions, ECC is a

necessity. This feature has filtered down from the larger computer systems and is now used by manufacturers of superior micro computer products.

**IMAGINE IBM PC RAM BOARD  
WITH THE FOLLOWING  
FEATURES FROM  
ONLY \$429.**

- 0 to 192K dynamic 150 ns RAM
- 1 bit error correction
- 2 bit error detection
- address bank switch selectable
- 64K increments
- 192K RAM \$699.

VR Data offers this superiority along with competitive pricing.

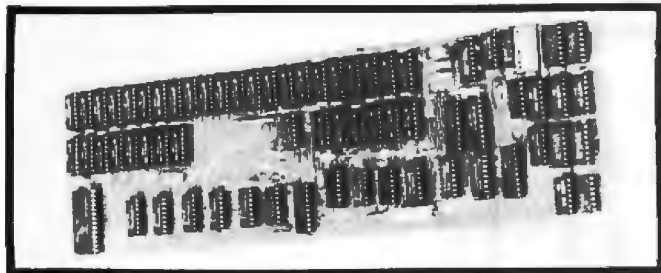

ONLY FROM

**VRdata**

777 Henderson Boulevard N-6  
Folcroft, PA 19032  
(215) 461-5300 (800) 345-8102

## EDGE-86

AN INDUSTRIAL QUALITY  
8086 OEM SYSTEM

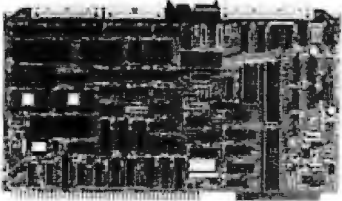

- **HARDWARE**
  - A Multibus<sup>™</sup> COMPATIBLE 8086 CPU BOARD WITH DMA FLOPPY CONTROLLER, INTERRUPT CONTROLLER, PROGRAMMABLE TIMERS, 3 SERIAL PORTS, TWO PARALLEL I/O PORTS, AND 8K BYTES OF PROM WITH BOOT STRAP LOADER FOR CPM 86<sup>™</sup>
  - 128K BYTES DYNAMIC RAM BOARD.
  - 2 SLOT MULTIBUS CARD CAGE, WITH COMPLETE DOCUMENTATION AND SCHEMATICS. ALL FOR \$1250
- **SOFTWARE**
  - CPM 86 OS WITH COMPLETE UTILITIES \$250.
  - OFF THE SHELF DELIVERY—

**EDGE MICRO SYSTEMS**  
195 W. EL CAMINO REAL, SUNNYVALE, CA 94086  
TELEPHONE: 408-738-4729

\* Multibus<sup>™</sup> is Intel<sup>™</sup> and CPM 86<sup>™</sup> are Digital<sup>™</sup> Register<sup>™</sup>

Circle 178 on Inquiry card.

## DAISY WHEEL PRINTER

NEW



**LETTER  
QUALITY**

- RS232C Serial Interface
- Parallel Interface
- Smith Corona TPI

**\$599**

**MICRO TECHNOLOGY**  
7817 Ivanhoe Ave  
La Jolla CA 92037  
(714) 457-2149

Circle 313 on Inquiry card.

## 5 Meg Hard Disk \$600.<sup>00</sup>

In introductory Offer — expand to Winchester Technology at 1/2 price.

Shugart SA1002 8" Hard Disk Drive. Optional controllers for IBM, S-100, STD BUS and others available.

Call Dave Starr at:  
**COMPUTER DYNAMICS, INC**  
(803) 877-7471  
105 S. Main St. Greer, S.C. 29615

Circle 105 on Inquiry card.

# wabash<sup>®</sup>

When it comes to  
Flexible Disks, nobody  
does it better than  
Wabash.

MasterCard. Visa Accepted  
Call Free: (800) 235-4137



**PACIFIC  
EXCHANGES**  
100 Foothill Blvd  
San Luis Obispo, CA  
93401 (In Cal call  
(805) 543-1037)

Circle 356 on Inquiry card.

## ZENITH/**Heath Users**



Double Your  
5 1/4" disk storage  
capacity without adding a drive.

Get twice as much from your H88 or H89 microcomputer. Our FDC-880H floppy disk controller, in conjunction with your 5 1/4" drives, for example, expands memory capacity from 256 bytes to 512 bytes per sector.

And it handles single and double-sided, single and double-density, 8" and 5 1/4" drives — simultaneously.

Call 714/275-1272 today or write for details.



**C.D.R. Systems Inc.**  
Controlled Data Recording Systems, Inc.  
7667 Vickers St., San Diego, CA 92111

Circle 79 on Inquiry card.

## GRAPHIC SOFTWARE ON CP/M FOR ENGINEERING & BUSINESS SYSTEMS

ON PLOTTERS, CRT'S, DOT MATRIX, AND W.P. PRINTERS  
MULTI-MEDIA FILE SYSTEMS  
MULTI-MEDIA FILE SYSTEMS

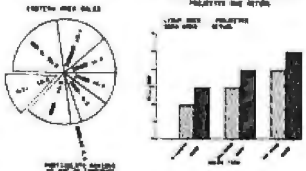

**PLOTWARE-Z**  
TRY IT OUT AND BUY  
FROM YOUR DEALER, OR CALL  
THE ENERCOMP COMPANY

P.O. BOX 28014  
LAKESIDE, CA 92039  
13033988 1644

PLOTWARE-Z GIVES YOU MAXIMUM RESOLUTION GRAPHICS. NOT A "BLOCKY" MESSY MAPPED DRAWING WITH BOXES. INTERACTIVE MENU DRIVEN. SORT, REVERSE, ROTATE, SCALE, OR ASCII DATA FILES. ON PLOTTERS, PRINTERS, SCREENS, ETC. WCPLOTTER .DEL FILES. \*CRIS-TEXT (R)3, SCREEN, ETC. HEATH USER INTERFACE. \*P.P. PRINTERS (S)3-DIGIT. PLOTTER. \*SOFTWARE UPWARD COMPATIBLE (ENR)COMP. \*DISP (L)3. \*MULTI-MEDIA UPWARD COMPATIBLE (P)PLOT. \*PROM (S)3. \*8086 DRAWING QUALITY CHECKER (S)1 (SHOW) HEATH OR COMPLEX. \*SCRIPT. \*ITALICS. \*GRAPHIC SYMBOLS OR "HIDE YOUR OWN" !! \*320 COMPLETE. \*325 MANUAL ONLY. \*VISA. \*M.C. \*THIS IS A BONUS JOINING BY PAPER AND OR SUPPLY AND S.

Circle 188 on Inquiry card.

continue, they become even faster—to a limit. Finally, when the key is released, the repetitions stop.

A major advantage of the automatic repeat feature is that there is no need to count the number of times an editing operation needs to be done—it's as simple as holding down a key until you see that the text has been changed to your liking. If the repetitions are too fast for the key to be released at the right moment, the key can be released early and a few extra taps of the key complete the change.

### Compared to Traditional Editors

Let's now compare its use with traditional text editors. Unlike traditional editors, the VDO text editor does not require a "command line" of characters to indicate what operations are to be done, how many times they are to be repeated, and what portion of the text is to be displayed. This greatly reduces the number of keystrokes (don't forget those "delimiters" normally needed), eliminates the need to remember special codes, eliminates the need to count characters or lines, eliminates the need to choose unique character strings (used to locate specific areas of the text), and eliminates the need to remember what mode the editor is in. There is also no need to remember where the cursor is and what changes have already been made.

With such distinct advantages, why hasn't this type of text editor become more common? The first reason is that the need to frequently and immediately redisplay a full page of text consumes a great deal of extra computer time and requires that the editing program be given first priority in situations where multiple tasks are being executed. This makes it unacceptable for timesharing systems. Another reason is that the speed of the display device must be great enough to handle a full-screen update within a fraction of a second, making all serial terminals and some micro-computer display devices unacceptable. But many microcomputer do not have these limitations.

So why didn't this form of text editing become prominent on micro-computers earlier? Apparently an

assumption is often made that microcomputers are simply scaled-down versions of larger computers, suitable only for scaled-down versions of traditional software. But by breaking away from tradition, microcomputer users can benefit from unique advantages.

I don't want to speculate which microcomputers are compatible with this editor, but my Digital Group microcomputer accommodates it without any hardware modifications. Specific comments on the video-display and keyboard requirements are included later, but for now it is sufficient to say that this editor can be implemented on many microcomputers without any hardware modifications.

### Important Concepts

In order to have a more concrete understanding of what it is like to use this text editor, I will present a simple example; but first, it is necessary to briefly explain three additional concepts central to its operation.

As in all text editors, the *cursor* is important. The cursor is a *pointer* to any location in the text. In this editor, the cursor is a special symbol (a right arrow in my version). The importance of the cursor is that it points to the position in the text where insertions will occur if an insertion operation is used, or it indicates which part of the text will be erased if an erasure operation is used. Also, since the cursor is always visible, its location determines which part of the text appears on the screen.

This editor is *character-oriented* rather than *line-oriented*. A character-oriented editor is more convenient to use because it allows characters within a line to be manipulated in a straightforward manner. In contrast, the smallest unit a line-oriented editor can operate on is a full line—although the careful use of search-and-replace operations allows changes to be made within a line without retyping it. Another advantage of character-oriented editors is that carriage returns (end-of-line indicators) can be inserted and erased—especially useful when a portion of a line needs to be moved to an adjacent line.

So far, I have implied that all the editing operations are associated with their own keys. However, such an approach is not practical due to the limited number of keys available. Since some of the operations do not require use of the automatic repeat feature, they are accessed via a menu mode—which requires *two* keystrokes. The first key pressed is the ESC (escape) key. A menu of available options, including their associated letters or symbols, appears on the screen:

- T Top
- B Bottom
- L Load
- S Save
- H Start Here
- C Copy Part
- \* Erase Part
- ! Erase All
- P Print

(Note that the two erasure operations make use of shifted characters to reduce the chance of erasing large portions of the text accidentally.) Pressing one of these keys causes the associated editing operation to be executed immediately. When the operation is done, the text reappears. This method is convenient to use because visual feedback is provided when the ESC key is pressed and because the key assignments are visible when needed.

### An Example of Its Use

We will now venture through a simple example of text editing that illustrates both the concepts already presented and the use of the editing operations yet to be explained.

Upon entering the editor, the screen is blank except for the cursor in the upper-left corner of the screen. Since you wish to edit an existing file, start by pressing the ESC key. A menu of special operations appears on the screen, including the Load operation with an L in front of it. Pressing L produces a request for information identifying the file to be loaded (either the name of the file or the block numbers that contain the text). After entering the necessary information, the text file is loaded and

# NEW FROM NETRONICS AUTO-PATCH HARD DISK

With plug-in multi-user ports  
Automatically Installs Itself Into  
Your Present CP/M® 2.2 Operating  
system & Floppy Disk Hardware.  
It's Exclusive!

6 megabytes \$2995.00 12 megabytes \$3495.00



What's the big concern of S100 owners when they consider adding Hard Disks? They worry that it will be difficult to install, that it won't be compatible with their present software and hardware, and that it may cause down-time on their S100 system.

Worry no more — Netronics new AUTOPATCH Hard Disk Systems are here. AUTOPATCH installs in just one-two-three: (1) plug in the hard disk S100 card; (2) run three short programs supplied on disk; (3) disable the boot on your floppy controller and enable the boot on your hard disk controller (this step not required if you wish to continue to boot to your floppy drives).

And that's it! The AUTOPATCH feature automatically finds the end of your existing BIOS and then self-relocates and patches itself into the existing BIOS. A virgin copy of CCP and BIOS are loaded into memory. A customized SBOOT is added to the front of CCP and the whole memory image is written to the reserved tracks on your hard disk. You can add up to 4 hard disks to the controller supplied. The new BIOS will automatically rename any old devices as B; and C; and define the hard disk as drive A. All with the lift of one finger!! If your BIOS is large you may have to re-sysgen your system down 1 or 2 k. If this is necessary the AUTOPATCH program will prompt you to do so.

AUTOPATCH Hard Disk Systems are available in 6 and 12 megabyte models. Included in the system 6 or 12 megabyte Hard Disk Drive . . . Controller for up to 4 Hard Disk drives . . . S100 Hard Disk card with provisions for adding 8 additional I/O ports to be used when adding a multi-user operating system . . . Power Supply . . . Deluxe Steel Cabinet . . . All necessary cables . . . AUTOPATCH Programs supplied on either 8" or 5 1/4" IBM formatted single density diskettes (specify style required) . . . Complete installation instructions . . . Fully wired and tested, ready to go.

### SPECIFICATIONS

Unformatted Recording Capacity: 6.4 or 11.6 MB  
No. of tracks: 612 or 1380 Data Transfer Rate: 3 ms  
Bytes/sector format: 512 . . . Communication Port:  
DO (other ports available on special order) Programs supplied on 5 1/4" or 8" single density IBM formatted diskettes (North Star CP/M® version available on special order)

### 10 DAY MONEY BACK OFFER

Continental U.S.A. Credit Card Buyers Outside Conn

**CALL TOLL FREE 800-243-7428**

To Order From Connecticut Or For Tech Assist  
Call (203) 354-9375

**NETRONICS R&D LTD. Dept.**

333 Litchfield Road, New Milford, CT 06776

Please send the items checked below.

AUTOPATCH/6 Hard Disk System . . . \$2995.00

AUTOPATCH/12 Hard Disk System . . . \$3495.00

Additional 6-megabyte drive with power supply, cabinet, cables and necessary software . . . \$1995.00

Additional 12-megabyte drive with power supply, cabinet, cables and necessary software . . . \$2495.00

All plus \$15.00 P&I (postage & insurance) For Canadian orders, double the postage (\$30.00) Conn res

add sales tax

Total Enclosed \$ \_\_\_\_\_

Personal Check  Cashier's Check/M.O.

VISA  MasterCard (Bank No. \_\_\_\_\_)

Acct. No. \_\_\_\_\_ Exp. Date \_\_\_\_\_

Signature \_\_\_\_\_

Print Name \_\_\_\_\_

Address \_\_\_\_\_

City \_\_\_\_\_ State \_\_\_\_\_ Zip \_\_\_\_\_

## S-100 Boards from S. C. Digital

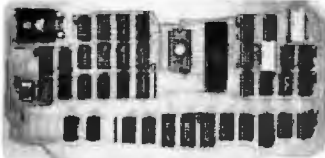

### NEW Z80B CPU BOARD

#### features: Model Z80 CPU

- 2, 4 or 8 Mhz clock, Sw selectable. • 22 bit addressing using memory mapping in 16K blocks making the addressable range to 4 mega bytes. • On board bank selectable 2KB or 4KByte of EPROM (not supplied) with Phantom disable.
- Jump on reset. • Provision to run two different CPU's on the same bus, such as forth coming 8086 board.

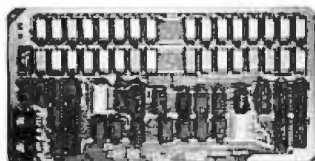

### 256K DYNAMIC RAM

#### features: Model 256KE

- 16 or 24 bit address. • 8/16 bit wide data • Transparent refresh with unlimited OMA, immune to Wait States, halts, resets. • Fast access time 180nsec from Smemr or Psync high, will run with Z80, Z8000 to 6mhz, 8080, 8085, 8086 to 8mhz without Wait States • Accepts 4116, 4164's.

### 32K STATIC RAM 'Uniselect: 3'

#### features: Model 32KUS

- Fully Static using 2k by 8 MOS chips. • 16 or 24 bit address. • 8/16 bit wide data. • Bank Select by port and bit in 32K block. • Two 16K block addressing with window capability in 2k increments. • EPROM can be mixed with RAM. • Fast access - 250nsec from address valid - will run with Z80, Z8000 to 4mhz, 8080, 8085, 8088, 8086 or 80000 to 8mhz without Wait States. • Provision for Battery Backup.

### Z80 CPU Board

#### features: Model CPU1 Z80

- 2 or 4mhz clock. • Jump on Reset. • 8 levels of prioritized vectored interrupts.

### I/O, MEMORY INTERFACE 'Interface'

#### feature: Model 3SPC

- 3 serials using UART, RS-232C or 20ma current loop.
- 1 parallel I/O with hand shakes. • 4K Ram, 4K EPROM (not supplied). Built in Kansas City Audio Cassette interface.
- Baud rates from 19.2K baud to 110 baud. Model 3SPC-N comes with less cassette, current loop, and ram, rom sockets.

### 2K Z80 Monitor Program

#### available for M:3SPC

features: many routines including breaker points, cassette record and play back . . . etc. Comes in 2 EPROMs and 1K RAM

All boards conform to IEEE896/S100 specifications, fully socketed, screened legends, masks, Gold contacts. Guaranteed One Full year

#### New price effective September 1, 1982

Model	Prices	with
Z80 CPU	\$340	Memory mapping 6MHz clock
256KE	\$895	256KB
256KE-128	\$895	128KB
32KUS	\$369	32KB with CMOS
32KUS-16	\$258	16KB with CMOS
32KUS-N	\$156	no memory chips
CPU1 Z80	\$219	with interrupt
3SPC	\$258	with cassette
3SPC-N	\$229	see above
2K Monitor	\$85	with source code

All boards come assembled and tested.

Delivery is within 3 to 5 working days MC, Visa or COD orders accepted. (Add \$8 for COD orders) Illinois residents add 5 1/2% sales tax.

O.E.M. & DEALER PRICING AVAILABLE

### S. C. DIGITAL

P.O. Box 906

1240 N. Highland Ave., Suite #4

Aurora, Illinois 60507

Phone: (312) 897-7749

the beginning of the text appears on the screen. The cursor is still in the upper-left corner.

Suppose a word used midway through the text needs to be changed. Press the PAGE | (page forward) key and hold it down. After pressing the key, the next page (full screen) of text replaces the first. A second later, the screen is repeatedly replaced with new pages of text at a rate of 10 pages per second until the key is released. Looking at the text presently filling the screen, you see that you have not reached the text area desired. A few taps of the PAGE | key bring the desired text into view.

To move the cursor to the line with the word, press the | (cursor down) key and hold it down. The cursor first moves to the beginning of the second line and then, after a one-second pause, quickly moves down the screen (always in the left column). Releasing the key at the right moment stops the cursor on the desired line.

Pressing the → (cursor right) key moves the cursor to the right (using the same automatic repeat feature) until it is almost to the word. A couple of extra taps of the same key and the cursor is to the immediate left of the word to be corrected, ready to make the change.

The process of replacing the incorrect word with the correct one requires use of the ERASE CHAR (erase character) key to erase the present word (again making use of the automatic repeat feature). Then, typing the desired word inserts it into the text at the proper location. As these changes occur, the portion of the line to the right of the cursor shifts left as the incorrect characters are erased, and it shifts right to make room for the inserted characters. Watching these changes take place is fascinating.

Although the explanation of finding and correcting the word in this example is lengthy, the time required to do it is only about 15 seconds. And, since the use of the operations is natural, editing requires less concentration than when using a traditional text editor, leaving you free to think about the text itself.

To move to the end of the text,

press the ESC key to enter the menu mode again and then press B (for Bottom). The screen is now filled with the last full screen of text and the cursor is at the end of the last line.

There is nothing special about adding characters to the end of the text; it is done simply by typing characters into the text at the end. At the end of a line, the carriage-return key is pressed to indicate the end of that line and the beginning of a new line.

When a character is incorrectly typed, the ← (cursor left) key is pressed once and normal typing is continued. Later, usually at the end of the line, the ERASE CHAR key with the automatic repeat feature, or the ERASE LINE key, is used to erase incorrect characters that have accumulated to the right of the cursor. This approach was chosen to reduce the number of keys needed. But if another key is available, a RUBOUT key (which erases the character just typed in) can easily be included. (However, I have seldom regretted the lack of a RUBOUT key.)

After the text has been modified, to save the updated version on floppy disk or tape, press the ESC key and then S (for Save). The editor will request information that indicates where you want it saved (as in the Load operation). After you have entered the information and the text has been saved, the first page of the text appears on the screen and the editor is ready for more editing.

### The Screen Format

Although the entire screen is available for displaying the text, only a portion of the text can appear on the screen at one time (unless the text is very short). Since the cursor must always be visible, only the text near the cursor can appear on the screen.

If the cursor is moved to a position not presently within view, scrolling takes place. *Vertical scrolling* changes the screen by shifting the lines up or down. In doing so, a new line appears at the top or the bottom of the screen and a line disappears at the opposite end.

Since lines can be longer than the display device can fit on a single line, *horizontal scrolling* allows the ends of

# RUSH THIS POSTAGE-PAID CARD FOR YOUR FREE CATALOG

NO SALESMAN WILL CALL

## NEW!

- Computer electronics with new TRS-80 Model III state-of-the-art computer
- TV/Audio/Video servicing with choice of computerized Heath/Zenith color TV, videocassette recorder, or stereo system
- Industrial Electronics for Instrumentation and Control technicians with TRS-80 Color Computer for hands-on training
- Electronic Design Technology with design lab program for creative circuit and equipment design



## CHECK ONE:

- Microcomputers and Microprocessors
- Color TV, Audio, and Video System Servicing
- Digital Electronics
- Electronics Design Technology
- Industrial Electronics
- Communications Electronics • FCC Licenses • Mobile • Aircraft • Marine
- Basic Electronics
- Small Engine Servicing
- Appliance Servicing
- Automotive Servicing
- Auto Air Conditioning
- Air Conditioning, Heating, Refrigeration, & Solar Technology
- Building Construction

Name \_\_\_\_\_ (Please Print) Age \_\_\_\_\_

Street \_\_\_\_\_

City \_\_\_\_\_ State \_\_\_\_\_ Zip \_\_\_\_\_

Accredited by the Accrediting Commission of  
the National Home Study Council

170-092

All career courses approved  
under GI Bill.  Check for facts.



NO POSTAGE  
NECESSARY  
IF MAILED  
IN THE  
UNITED STATES

**BUSINESS REPLY CARD**

FIRST CLASS PERMIT NO. 10008 WASHINGTON, D.C.

POSTAGE WILL BE PAID BY ADDRESSEE

**NRI Schools**

McGraw Hill Continuing  
Education Center  
3939 Wisconsin Avenue  
Washington, D.C. 20016





# Now NRI takes you inside the new TRS-80 Model III microcomputer to train you at home as the new breed of computer specialist!

NRI teams up with Radio Shack advanced technology to teach you how to use, program and service state-of-the-art microcomputers...

It's no longer enough to be just a programmer or a technician. With microcomputers moving into the fabric of our lives (over 250,000 of the TRS-80™ alone have been sold), interdisciplinary skills are demanded. And NRI can prepare you with the first course of its kind, covering the complete world of the microcomputer.

## Learn At Home in Your Spare Time

With NRI training, the programmer gains practical knowledge of hardware, enabling him to design simpler, more effective programs. And, with advanced programming skills, the technician can test and debug systems quickly and easily.



Training includes the TRS-80 Model III microcomputer, professional LCD multimeter, the NRI Discovery Lab, Computer Assisted Instruction programs and hundreds of demonstrations and experiments.

(TRS-80 is a trademark of the Radio Shack division of Tandy Corp.)



Only NRI gives you both kinds of training with the convenience of home study. No classroom pressures, no night school, no gasoline wasted. You learn at your convenience, at your own pace. Yet you're always backed by the NRI staff and your instructor, answering questions and giving you guidance.

## You Get Your Own Computer to Learn On and Keep

NRI training is hands-on training with practical experiments and demonstrations. You don't just program your computer, you go inside it...watch how circuits interact...interface with other systems...gain a real insight into its nature.

You also work with an advanced liquid crystal display hand-held multimeter and the NRI Discovery Lab,® performing over 60 separate experiments. Both microcomputer and equipment come as part of your training for you to use and keep.

## Computer Assisted Instruction

Your TRS-80 even helps train you. You receive 8 special lesson tapes in BASIC

computer language. Using them in your microcomputer, you "talk" to it as you progress. Errors are explained, graphics and animation drive home key points. Within a matter of minutes, you'll be able to write simple programs yourself.

## Send for Free Catalog... No Salesman Will Call

Get all the details on this exciting course in NRI's free, 100-page catalog. It shows all equipment, lesson outlines, and facts on other electronics courses such as Electronic Design, Industrial Electronics, TV/Audio/Video Servicing... 11 different career opportunities in all. Keep up with the latest technology as you learn on the latest model of the world's most popular computer. If card has been used, write to:



**NRI Schools**  
McGraw-Hill Continuing  
Education Center  
3939 Wisconsin Avenue  
Washington, D.C. 20016

We'll give you tomorrow.

Operation	Key(s) Used	Description of Operation	Special Cases in Which No Change Occurs
CURSOR UP	↑	If the cursor is already at the beginning of a line, the cursor is moved to the beginning of the previous line. Otherwise, it is moved to the beginning of the same line.	The cursor is already at the beginning of the text.
CURSOR DOWN	↓	The cursor is moved to the beginning of the next line.	The cursor is already at the end of the text.
CURSOR LEFT	←	The cursor is moved left by one character. If the cursor is at the beginning of a line, the cursor is moved to the end of the previous line.	The cursor is already at the beginning of the text, or there is no more room in memory (in which to expand compressed-space-bytes).
CURSOR RIGHT	→	The cursor is moved right by one character. If the cursor is at the end of a line, the cursor is moved to the beginning of the next line.	The cursor is already at the end of the text, or there is no more room in memory (in which to expand compressed-space-bytes).
PAGE FORWARD	PAGE ↑	A new full screen of text immediately below the presently visible text is displayed. The cursor is moved to the upper-left corner of the screen. If the end of the text is already on the screen, the cursor is moved to the end of the text.	The cursor is already at the end of the text.
PAGE BACKWARD	PAGE ↓	A new full screen of text immediately above the presently visible text is displayed. The cursor is moved to the upper-left corner of the screen.	The cursor is already at the beginning of the text.
TOP	ESC, T	The cursor is moved to the top (beginning) of the text.	The cursor is already at the beginning of the text.
BOTTOM	ESC, B	The cursor is moved to the bottom (end) of the text.	The cursor is already at the end of the text.
INSERT CHARACTER	Any character key	The appropriate character (indicated by the key that was pressed) is inserted into the text to the immediate left of the cursor.	There is no more room in memory.
INSERT CARRIAGE RETURN	CR	A carriage return is inserted to the immediate left of the cursor. (This creates a new line or divides an existing line into two lines.)	There is no more room in memory.
ERASE CHARACTER	ERASE CHAR	The character or carriage return to the right of the cursor is erased.	There is no text to the right of the cursor.
ERASE LINE	ERASE LINE	If the cursor is at the beginning of a line, the entire line is erased (including the carriage return at the end). Otherwise, the portion of the line to the right of the cursor is erased (without erasing the carriage return at the end).	There is no text to the right of the cursor or the cursor is at the end of a nonempty line.
ERASE ALL	ESC, !	The entire text is erased.	There is no text in the editor.
PRINT	ESC, P	The entire text is sent to the printer. (No changes are made in the text.)	There is no text in the editor.
LOAD	ESC, L	Text from the mass-storage device is inserted into the text to the immediate right of the cursor. (This operation is used both for combining text files and for initially loading a text file into the editor.)	There is not enough room available in memory.
SAVE	ESC, S	A copy of the entire text is saved on the mass-storage device. (The text remains in the editor.)	There is no text in the editor.

**Table 1: Editing operations for the VDO text editor. Except for the SHIFT operation, they can be classified in four basic categories: cursor-movement operations, insertion operations, erasure operations, and operations that transfer text to and from the peripheral devices (mass storage and printer). The operations that do not involve the use of the ESC key can be repeated quickly using the automatic repeat feature. Additional comments concerning the use of these operations are given in the text.**

START HERE	ESC, H	This operation defines the beginning of the portion of text to be used in the COPY or ERASE PART operations.	(Always has an effect.)
COPY	ESC, C	A copy of the portion of the text between the "START HERE" location and the present cursor location is saved on the mass-storage device. (The text is not changed.)	There is no text in the editor, or the cursor has been moved ahead of the "START HERE" location.
ERASE PART	ESC, *	The portion of the text between the "START HERE" location and the present cursor location is erased.	There is no text in the editor, or the cursor has been moved ahead of the "START HERE" location.
SHIFT	CTRL-A	If the character to the right of the cursor is an alphabetic (A-Z) character, it is shifted between UPPERCASE and lowercase (whichever is opposite). Also, regardless of whether the character was shifted, the cursor is moved right one character (equivalent to the CURSOR RIGHT operation).	There is no text to the right of the cursor.

long lines to be viewed whenever desired. Horizontal scrolling is analogous to vertical scrolling, except that the text (all of it) is shifted left or right. This approach was taken rather than using wraparound (in which a second line is used for displaying the extra characters) because the appearance of the text can be confusing with that approach and because the effect of the CURSOR UP and CURSOR DOWN operations would be erratic.

#### Explanation of Editing Operations

A full list of the operations implemented in this text editor is given in table 1. The operations were designed to be simple but powerful. With the exception of the shift operation, they are classified in four general categories:

- cursor-movement operations
- insertion operations
- erasure operations
- operations that transfer text between the peripheral devices and the editor

The information presented in table 1 clearly defines what these operations do, but explanations of how they are used are given below. (Since the information in the table is not repeated here, the table should be referenced while reading this section.)

To make the movement of the cur-

sor easy, eight cursor-movement operations are available. They move the cursor forward and backward by character (CURSOR RIGHT and CURSOR LEFT), by line (CURSOR DOWN and CURSOR UP), by page (PAGE FORWARD and PAGE BACKWARD), and to the ends of the

text (BOTTOM and TOP). In conjunction with the automatic repeat feature, they allow the cursor to be moved easily both short and long distances.

The only cursor-movement operations that have not yet been fully explained are the PAGE FORWARD

## Music and Art Cross Paths at the Computer

### DIGITAL HARMONY On the Complementarity of Music and Visual Art By John Whitney

BYTE Books is pleased to offer *Digital Harmony*, a major new work by John Whitney. *Digital Harmony* lays the foundation for the new field of audiovisual art made possible by microcomputers. Whitney, whose film art has been an influence on technological arts and cinematic special effects from STAR WARS to 2001: A SPACE ODYSSEY, explores the special union of music and computer graphics. Colorful illustrations as well as the program listings that generated them are included. The descriptions are sufficient for any composer or computer experimenter to transform the small computer into an ideal instrument for creating compositions in aural and visual art.

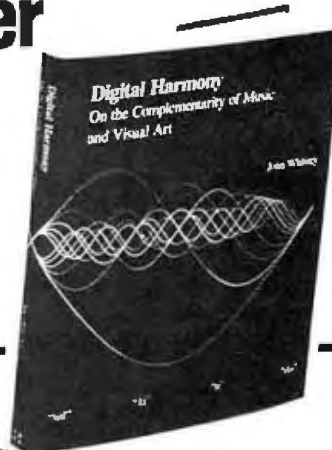

**BYTE  
BOOKS**

Please send me: \_\_\_\_\_ copies of DIGITAL HARMONY \$21.95

Add 75¢ per book to cover postage and handling. Please remit in U.S. funds or draw on a U.S. Bank.

Check enclosed in the amount of \$\_\_\_\_\_

Bill VISA Bill MasterCard

Acct No. \_\_\_\_\_ Expires \_\_\_\_\_

Name \_\_\_\_\_

Title \_\_\_\_\_

Company \_\_\_\_\_

Street \_\_\_\_\_

City \_\_\_\_\_ State \_\_\_\_\_ Prov \_\_\_\_\_ Code \_\_\_\_\_

Call our toll-free Number

**800-258-5420**

70 Main St.  
Peterborough, NH 03458



B9

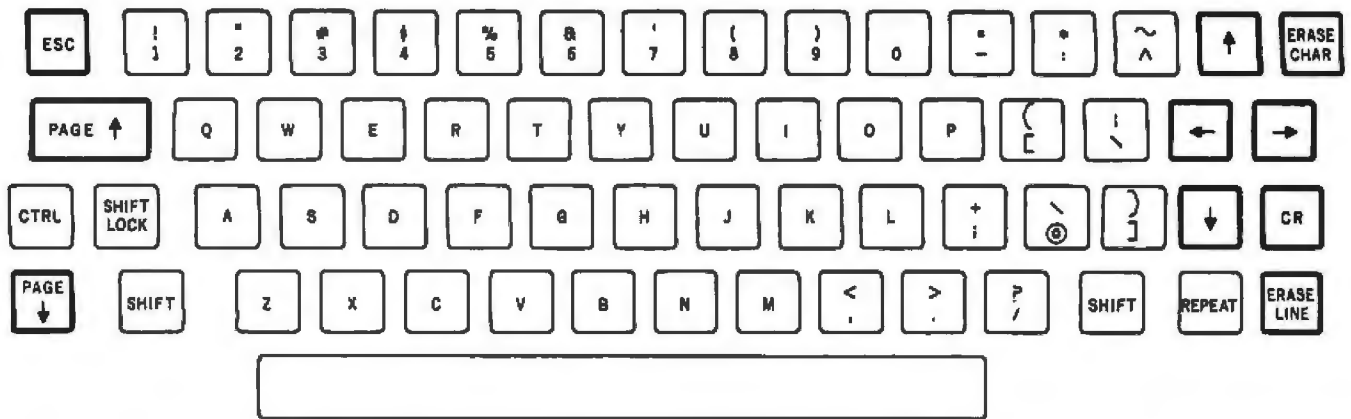

**Figure 1:** The keyboard layout on the author's system. The important noncharacter keys are outlined in boldface. Note the natural orientation of the four clustered cursor-movement keys (with the arrows). Pressing any character key causes that character to be inserted into the text. Except for the SHIFT operation (accessed by the SHIFT-A combination), the remaining editing operations are accessed by pressing the ESC (escape) key to enter the menu mode.

The author's keyboard is not standard with respect to the SHIFT and CTRL keys. Also, the REPEAT key is not used. The special editing keys shown here replace unneeded keys marked BREAK, LINE FEED, TAB, BACKSPACE, HERE IS, CLEAR, DELETE, and two unassigned keys.

and PAGE BACKWARD operations. Their effect is to display the full screen of text immediately following or preceding the text presently visible—analogue to flipping the pages of a book. The cursor is moved to the

upper-left corner of the screen in either case, regardless of where it was before. These operations are very useful for moving through the text quickly or for finding a specific area of the text.

The insertion operations—INSERT CHARACTER and INSERT CARRIAGE RETURN—allow letters, numbers, symbols, spaces, and carriage returns to be inserted into the text wherever desired. Pressing any character key or the carriage-return key causes the character or a carriage return to be inserted into the text to the immediate left of the cursor. This allows characters to be entered from left to right, the normal direction for typing.

Although the insertion of a carriage return is done the same as any other character, the effect is worth commenting on. If a carriage return is inserted into the middle of a line, it separates the line into two separate lines; but if a carriage return is inserted at the beginning or the end of a line, a new empty line is created wherever the cursor is, and the line can then be filled if desired.

The erasure operations—ERASE CHARACTER, ERASE LINE, and ERASE ALL—allow characters, lines, or the entire text to be erased. A fourth erasure operation, ERASE PART, is also available, but because it is often used in conjunction with one of the text-transfer operations, it will be discussed later.

The ERASE CHARACTER operation is straightforward. Whatever character is to the immediate right of the cursor is erased by this operation.

## INTRODUCING MORE REASONS FOR TRYING CONTROL DATA FLEXIBLE DISKS RIGHT NOW.

### 2 FREE IN EVERY BOX.

Here's two *more* reasons to try Control Data flexible disks. *Two free disks* in every specially marked box of 10. That's 12 disks, or 20% more in every box.

Control Data flexible disks are guaranteed error-free. We manufacture and test every disk to exacting standards.

Now both home and business users can enjoy Control Data quality—and at a 20% added value. Available in both 8-inch and 5¼-inch sizes, in a variety of formats. From now until Dec. 31, 1982 get two free just for trying them.



**COMPUTER PARTS EXCHANGE**  
19821 Nordhoff Street • Northridge, CA 91324  
PH: 213-709-4003 Telex 18-1537



In conjunction with the automatic repeat feature, it allows any short portion of the text to be easily erased. If the character to the right of the cursor is a carriage return (i.e., if the cursor is at the end of a line), this operation erases the carriage return, causing two lines to be combined into one longer line.

The effect of the ERASE LINE operation is that the remainder of the line containing the cursor, starting at the location of the cursor, is erased. However, the carriage return at the end of the line is erased only if the cursor is at the beginning of the line. This distinction provides two modes of operation that are both useful: in cases where all the characters on the line are to be erased, it is usually desirable to also erase the carriage return at the end. But in cases where the beginning part of the line is to remain intact, the carriage return is retained to avoid combining that line with the next line.

The final erasure operation, ERASE ALL, is self-explanatory in its effect, but there might be some question as to why it is needed. Unlike some editors, this editor does not have to be exited and reentered in order to finish editing one file and start editing a different file. Instead, the updated first file is saved, the ERASE ALL operation is used to eliminate that file from memory, and the second file is then loaded into the editor. This approach allows greater flexibility in manipulating the files on mass storage.

It should be noted that the text files referred to above must be short enough to fit into the main memory entirely. Although this type of text editor could be programmed to handle very large files (provided a disk drive is used as the mass-storage device), the additional programming effort needed to implement it would be substantial.

This editor accommodates two types of peripheral devices: a printer and some form of mass storage. Any of the usual mass-storage devices—audio-cassette tape recorders, digital-cassette tape drives, floppy-disk drives, or hard-disk drives—can be used for storing the text files.

The only operation that pertains to the printer is the PRINT operation. It sends the entire text to the printer to be printed. (This print operation does not have text-formatting capabilities—sometimes included in a text editor to form a word-processor program.)

Three operations can transfer text between the mass-storage device and the editor: the LOAD, SAVE, and COPY operations. The LOAD operation gets a file of text from the mass-storage device and inserts it into the text at the location pointed to by the cursor. This operation is used both for initially loading text into the editor when it is empty and for combining previously created text files. The SAVE operation stores the entire text file on the mass-storage device. It is used not only to save the final version of a text file, but also to store backup or intermediate versions of the text. Finally, the COPY operation saves just a portion of the text on the mass-storage device. It is usually used for making a copy of a portion of text needed elsewhere (either in the same file or another).

Since the COPY operation cannot be used by itself to indicate which part of the text is to be copied, the START HERE operation is used to indicate where the section to be copied begins. The COPY operation is then used to indicate the end of the section to be copied and it initiates the transfer operation. However, if the cursor is moved above the "START HERE" location before the COPY operation is used, the COPY operation will produce an error message (due to the potential for accidentally changing the starting point).

The COPY operation is also useful for moving (as opposed to just copying) portions of text to different positions in the file. To allow this to be done easily, the ERASE PART operation is included. When it is used immediately after the COPY operation, it erases the portion of text just copied. The copied portion of text can then be inserted elsewhere by using the LOAD operation.

If you are familiar with editors that incorporate special buffers for saving text, it may have occurred to you that

# Fancy Shmancy

Elaborate microprocessor development systems cost a lot of money, and they can close off your engineering options by locking you into just one or two kinds of chips. Sound familiar? Well, read on—we've got a better idea.

Use your desktop computer; anything that will run CP/M\* is fine. With our microprocessor cross-assemblers you can produce software for eleven of the most popular chip families, and more are on the way.

In two years on the market, our cross-assemblers have gained a reputation for quality, performance, and reliability. Hundreds of industrial R&D labs and several major semiconductor houses have found these products a fast, cost-effective way to develop their microprocessor software. We invite you to join them.

## CP/M CROSS-ASSEMBLERS

Extremely fast absolute assemblers, running under CP/M. Generate object file (Intel hex or Motorola S-record format) and listing from standard assembly language for the target processors listed. Features include comprehensive syntax checking, listing control, nested conditional assembly, and insertion of external source files. All versions listed have been thoroughly field-tested and are available now.

	XASM05 . . . . .	6805
	XASM09 . . . . .	6809
	XASM18 . . . . .	1802
	XASM48 . . . . .	8048/41
	XASM51 . . . . .	8051
	XASM65 . . . . .	6502
	XASM68 . . . . .	6800/01
NEW!	XASM75 . . . . .	NEC 7500
	XASMF8 . . . . .	F8/3870
NEW!	XASMZ8 . . . . .	Z8
	XASM400 . . . . .	COP400

Assemblers . . . . . \$200.00 each  
except XASM75 . . . . . \$500.00

Visa and Mastercard accepted. We ship on 8" single-density and Softcard + 5.25" diskettes. Ask us about other formats. OEM INQUIRIES INVITED.

\*Trademark of Digital Research  
+ Trademark of Microsoft



**AVOCET  
SYSTEMS INC.**

804 S. STATE ST., DOVER, DEL. 19901  
302-734-0151  
BY82

# Best Prices!

**hp HEWLETT  
PACKARD**  
**HP-41CV, \$237**  
**HP-41C, \$189**



HP-41 CARD READER ..... \$165  
HP-41 OPTICAL WAND ..... 99  
HP-41 PRINTER (82143A) ..... 289  
HP-IL INTERFACE MODULE ..... 95  
HP-IL PRINTER (82162A) ..... 375  
HP-IL DIGITAL CASSETTE DRIVE ..... 419  
HP-IL VIDEO INTERFACE ..... CALL  
HP-41 EXT. FUNC. MEMORY MOD. .... 62  
HP-41 EXT. MEMORY MODULE ..... 62  
HP-41 TIME MODULE ..... 62

HP-12 ] **\$115**  
HP-15 ] *Your Choice*  
HP-16 ]



**HP-11C . . . \$79**

**IBM** QUADBOARDS BY  
QUADRAM, CORP.  
MEMORY EXPANSION /CLOCK /PARALLEL  
INTERFACE /RS232 INT. *ON ONE BOARD!*  
QUADBOARD w/64K INSTALLED ..... \$495  
QUAD BOARD w/256 K INSTALLED ... \$795



**ATARI 800 \$649**  
**ATARI 400, \$259**

ATARI 810 DISK DRIVE .....  
ATARI 410 PROGRAM RECORDER ..... 79  
ATARI 16K MEMORY MODULE ..... 75  
ATARI 825.80 COLUMN PRINTER ..... 565  
ATARI 850 INTERFACE ..... 159

**Texas Instruments**  
**TI-99/4, \$298**

TI-58C ..... \$79 TI-59C ..... \$169  
TI-55 II ..... 36 TI-LCO PROGMR. 55  
TI-PC-100C PRINTER/PLOTTER ..... \$149

**Commodore**  
**VIC20 . . \$239**

VIC-20 DATASETTE ..... \$67  
VIC 1515 PRINTER ..... 339  
VIC MODEM ..... 69  
VIC SUPER EXPANDER ..... 59

**NEC** PC-8001 COMPUTER ... \$749  
PC-8031 DUAL DISK ..... 749  
PC-8023 PRINTER ..... 499

**SHARP**  
PC-1500 POCKET COMPUTER ... \$219  
CE-150 FOUR-COLOR PRINTER ... 185

APPLE II 48K ... Call  
APPLE III 128K ... Call  
MICROSOFT 16K RAM (for APPLE) ..... 145

MICROSOFT PREMIUM SYSTEM (for APPLE) .. 599  
AMDEK 13" COLOR MONITOR ..... 349  
ZENITH 121 GREEN PHOS. MONITOR. . . 119  
**NEW SMITH-CORONA  
DAISYWHEEL PRINTER, TP-1...\$649**

**Personal (315) 478-6800**  
**PCS** computer systems  
*All prices are  
subject to change  
without notice*  
P.O. Box 1073  
Syracuse, N.Y. 13201  
*Prices do not  
include shipping*

this scheme for storing and retrieving sections of the text on mass storage allows the same types of manipulations to be done, but without the complicated special commands needed to manipulate those special buffers. This ability to transfer text to and from mass-storage files allows virtually any manipulations of text to be done with a few simple operations.

As mentioned earlier, the use of the ERASE PART operation is not restricted to its use with the COPY operation, although it is most commonly needed there. In conjunction with the START HERE operation, it allows large portions of the text to be erased easily.

The explanation of the SHIFT operation has been left for last because it does not fit into any of the four basic categories. It transforms letters from uppercase to lowercase or vice versa, but it affects only letters (not numbers, symbols, etc.), and it moves the cursor right by one character. When alternately used with the CURSOR RIGHT key, it allows text to be easily changed to lowercase where needed, having been entered in uppercase only. I implemented this operation to allow the use of lowercase letters on my system (which has a keyboard that does not generate them); on most microcomputers, this operation is not needed.

That completes the explanation of the editing operations chosen for this editor. Although they are few and simple, they allow textual material to be manipulated easily according to normal needs. The only useful operations this editor lacks are the SEARCH and REPLACE operations. Although traditional editors would be impractical without them, they are optional on this editor. (They are particularly useful for changing the names of variables in a program or changing key words in a form letter. However, they are not needed in this editor for helping to move the cursor to a desired location or for manipulating characters within a line—their primary function in traditional editors.)

### Keyboard Requirements

Although it would be nice if all the

operations had their own keys, most keyboards do not have enough keys. The operations that should, if at all possible, have their own keys are the CARRIAGE RETURN, CURSOR UP, CURSOR DOWN, CURSOR LEFT, CURSOR RIGHT, ERASE CHARACTER, and ESC operations. If available, keys not otherwise used by the editor can be used for these operations. Otherwise, the SHIFT and CTRL (control) keys must be used in conjunction with particular character keys to control these and the remaining operations—although this significantly reduces the convenience of the editor. The other operations that must be accessed by unique codes (either by being assigned to their own keys or through the use of the SHIFT and CTRL keys) are the ERASE LINE, PAGE FORWARD, PAGE BACKWARD, and SHIFT operations. These operations require unique codes because they must be accessible via the automatic repeat feature. The key assignments for my keyboard are shown in figure 1.

Since the automatic repeat feature is implemented in software, there must be a software-testable connection to indicate when a key is being held down. The ASCII (American Standard Code for Information Interchange) code for the key being pressed must also be available to the computer, but it need not be supplied to the same input port as the key-pressed-status bit.

The subroutine to implement the automatic repeat feature pauses between repeated operations or waits for another key to be pressed after the key has been released. If this editor is implemented on a system without provisions for allowing the key-pressed-status to be checked, an extra connection must be added. Although other methods for implementing the automatic repeat feature are possible, they require significant changes to the program.

### Video-Display Requirements

The most critical hardware requirement for implementing the VDO text editor is that the entire video-display screen must be capable of being rewritten within about a tenth of a

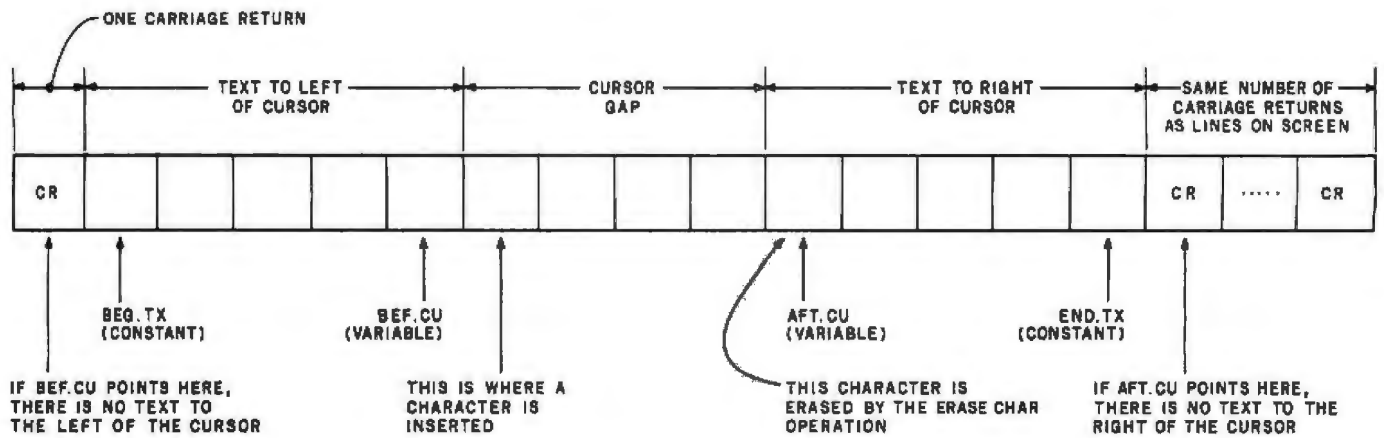

**Figure 2:** The structure of the text as stored in memory. Carriage returns are added to the ends of the text area to simplify the editor program, but they are not considered part of the text. The available text area extends from *BEG. TX* to *END. TX*, but the *BEF. CU* and *AFT. CU* pointers indicate how much of this area contains text; the unused portion constitutes the "cursor gap." The text code used for characters (except spaces) and carriage returns is ASCII, with the eighth bit set to 1. Spaces are represented when the eighth bit is set to 0, in which case the other 7 bits indicate the number of adjacent spaces stored at that location. In this diagram, memory-address numbers increase to the right.

second, preferably even faster. Thus, any display device connected via a serial line is too slow. The only display devices fast enough are those connected in parallel and those that are memory-mapped. (The memory-mapped type stores the characters in a special section of memory. The display circuitry repeatedly accesses those memory locations as they are needed for the display.)

In order to find out how fast your video-display device can be updated, write an assembly-language program to fill the screen 1000 times (with any characters) and then erase the screen. Measure the time between the first update and the time at which the screen goes blank. Divide the measured time (in seconds) by 1000, and that is the time required for up-

dating the screen once. For best results, the time for one update should be less than 0.05 seconds, since that leaves one-twentieth of a second for the computer to do the editing operation and determine which characters to display.

For purposes of comparison, my display device—a parallel-connected type with 16 lines of 64 characters—can be updated in 0.04 seconds. With the Z80 microprocessor running at 2.5 megahertz, the execution time for one update, including calculations, is about 0.08 seconds.

If your display device is not fast enough, the program will not be usable as written. However, a compromise form of text editor could be implemented by keeping only one line (or a few lines) of text visible, instead

of a full page. The PAGE FORWARD and PAGE BACKWARD operations could then be used to display a full screen of text each time they are used. The results are not as impressive, but they are preferable to many traditional editors.

There are only two operations that the text-editor program requires of the video-display device: to display a character in the next position on the screen, and to reset the display so the next character to be displayed will appear in the upper-left corner of the screen. There is no need for a carriage-return operation because the program assumes that a new line is automatically started when the right side of the screen is reached. The two subroutines that handle the display device can be written to handle most



## THE 488+3

### IEEE 488 TO S-100 INTERFACE

IEEE-488



S-100

- Handles all IEEE-488 1975/78 functions
- IEEE 696 (S-100) compatible
- MBASIC subroutines supplied; no BIOS mods required
- 3 parallel ports (8255A-5)
- Industrial quality; burned in and tested
- \$375

[Dealer inquiries invited]

## D&W DIGITAL

1524 REDWOOD DRIVE  
LOS ALTOS, CA 94022 (415) 966-1460

hardware configurations, but the presence of a visible "hardware cursor" may require some changes in the program itself.

### Internal Representation of Text

The code used for storing the text includes the standard ASCII 7-bit code. The extra (eighth) bit of each byte is used to distinguish between ASCII (indicated by the most significant bit set to 1) and a special representation of multiple-adjacent spaces (most significant bit set to 0). These "compressed-space-bytes" allow a

series of adjacent spaces to be combined into a single byte by using the 7 least significant bits as a binary number indicating the number of spaces represented (up to 127). This representation can significantly reduce the amount of memory required for storing textual material, especially when indentation is a dominant feature of the text—as in most computer programs. This special implementation of spaces complicates the editor program, but the saving in memory usage is worth it.

The editor recognizes ASCII car-

riage returns as end-of-line indicators, but it assumes that all other ASCII values are displayable characters. Therefore, control codes (such as Tab, Line Feed, and Backspace) are treated as characters if they get into the text. The one code that could cause the program to crash is the binary number 0 (which would otherwise represent 0 adjacent spaces). But as long as all the text is entered via this editor, problems do not arise since checks are made to avoid such insertions.

The text is stored in a single continuous block of memory located anywhere in programmable memory. Pointers are used to divide the area into three parts: the text to the left of the cursor, the text to the right of the cursor, and the cursor gap. (See figure 2 during this and the following explanations.) The two halves of the text, corresponding to the text to the left and right of the cursor, are stored near the ends of the available memory area, with the beginning of the text at the lower end and the end of the text at the higher end. The section of memory between the two halves of text is called the cursor gap and its contents are unimportant. The advantage of keeping the unused portion of memory at the cursor location is that insertions and erasures do not require the shifting of numerous characters, allowing the editing operations to be done quickly.

Four variables are used to point to the boundaries of these three areas: BEG.TX (begin text), BEF.CU (before cursor), AFT.CU (after cursor), and END.TX (end text). The locations they point to are best understood by referring to figure 2. As the figure indicates, the BEG.TX and END.TX pointers point to the first and last bytes of text, respectively, and the BEF.CU and AFT.CU pointers point to the bytes to the left and right of the cursor, respectively. The BEG.TX and END.TX pointers always point to the same memory locations despite changes in the text. But either or both of the BEF.CU and AFT.CU pointers change with almost every editing operation. As indicated in the figure, special considerations apply when the cursor is at either end of the text, or if

Whitesmiths, Ltd.  
is now shipping Pascal Compilers  
for 10 (count 'em ten) different  
operating system families:

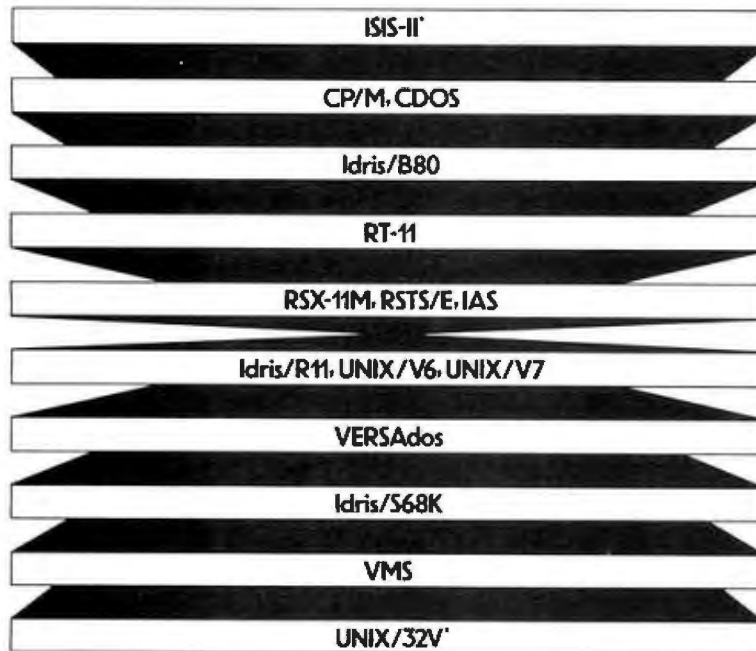

\*Available in source form only.

Idris is a trademark of Whitesmiths, Ltd. UNIX is a trademark of Bell Laboratories. CP/M is a trademark of Digital Research. RSX-11M, RSTS/E, RT-11, LSI-11, VAX, and VMS are trademarks of Digital Equipment Corporation. VERSA dos is a trademark of Motorola Inc.

All implementations support the full ISO Pascal (Level 0). All pass the Tasmanian Validation Suite with flying colors.

You can partition your Pascal program into separately maintainable files. You can write library functions to add to the extensive set we give you. And you can mix in modules written in other languages, like assembler or C.

In fact, a C Compiler comes with every Pascal Compiler we sell. Prices start at \$950.00. Write or call.

Distributors: Australia, Fawcett Pty Ltd. P.O.B 224 Hurstville NSW 2220 570-6100  
Japan, Advance Data Controls Corp. Chiyoda-ku, Tokyo 03263-0383  
United Kingdom, Real Time Systems, Newcastle upon Tyne 0632 733131

Whitesmiths, Ltd.

Parkway Towers, 'B', 485 US Route 1 So., Iselin, New Jersey 08830 (201) 750-9000 Telex: 645592



there is no text at all. (When there is no text to the left of the cursor, BEF.CU = BEG.TX - 1; when there is no text to the right of the cursor, AFT.CU = END.TX + 1.)

There are three basic ways in which the text can be modified:

- moving the cursor
- erasing text
- inserting text

These changes are made as follows: Cursor-movement operations are achieved by moving one or more of the bytes adjacent to the cursor gap to the opposite end of the cursor gap (keeping the bytes in the same order) and updating the BEF.CU and AFT.CU pointers to indicate the new structure. Erasure operations (for text to the right of the cursor) are achieved by increasing the value of the AFT.CU pointer. (Although no changes are made in the text area, some of the bytes of text are reclassified as being part of the cursor gap.) Finally, the insertion of text (to the left of the cursor) is done by storing new byte(s) at the lower-address end of the cursor gap and increasing the value of BEF.CU to point to the last byte of the inserted text. Although these three basic types of editing operations are simple in concept, complications arise because of the many special cases that can occur.

A final comment about the internal text format is that extra carriage returns are added to each end of the text area to reduce the number of special cases to be checked (see figure 2). However, these carriage returns are not considered part of the text being edited.

### Program Implementation

The source listing of the VDO text editor will be presented next month in part 2 of this article. It is written in assembly language for either 8080 or Z80 microprocessor-based computers and occupies less than 2.2K bytes of memory. The comments provide the documentation necessary for implementing it, but implementation does require a familiarity with assembly-language programming and an understanding of the operation of your

computer. Eight input/output subroutines, examples of which will be included next month, must be written to interface the program with either your input/output devices or your operating system. The comments also enable the program to be modified to fit specific needs or even to be translated into another machine's language. (In addition to the obvious reasons for including clear comments, I find that software is actually easier to write if clear comments are written at the same time the computer instructions are written.)

I am offering this program as a commented source listing to help other computer experimenters who cannot accommodate the commercially available editors of this type. However, the implementation of this program is not trivial, so if your system is compatible with a ready-to-use editor that offers the conveniences of this approach, you may be better off trying it instead. But whichever route you take, you can look forward to more enjoyable and productive editing sessions on your microcomputer. ■

## CP/M USERS LOOK OUT: THE BEST OF BOTH WORLDS INTRODUCING S/S-PASCAL BOTH IN NATIVE CODE AND P-CODE

S/S-PASCAL VERSION 3.0 (Native Code) AND 3.5 (P-Code)  
FOR 8080 - 8085 - Z80 — REQUIRE ONLY 32K OF MEMORY!

A bilingual compiler! S/S-PASCAL speaks English  
and French (or Spanish or German or Italian . . .)

**COMPILE FAST IN P-CODE**  
then when your program is ready  
**EXECUTE FASTER IN NATIVE CODE**

*Available in the following formats: 8" SD, North Star  
Osborne, Micropolis Mod II, Apple CP/M, Superbrain*

Write to get the whole story, or better send \$30.00 for  
Demo Discette and tutorial manual (150 pages)

Demo 1: Compiler without READ statements

Demo 2: Source limited to 50 statements

### COMPARE!

	Execute (seconds)	Total Size (bytes)
S/S-PASCAL (Native Code)	12.5	1300
PASCAL MT + *	19.0	3043
PASCAL/Z*	109	3328
S/S-PASCAL (P-Code)	120	13000
UCSD PASCAL*	239	8282
PASCAL/M*	450	21933

Re: BYTE, September 1981, page 180  
A high level language Benchmark  
\*TRADEMARK

### • Standard PASCAL features plus

- Generates optimized native code
- Compiles directly into .com file
- External assembler subroutines
- Random access files
- 14 digit BCD floating point reals
- Chaining and overlays
- Dynamic strings
- Powerful string manipulation
- Direct access to memory
- Address and size functions
- NEW, DISPOSE, MARK, RELEASE
- ASSIGN, RENAME, ERASE
- and more . . .

S/S-PASCAL NATIVE CODE & P-CODE	\$ 360.00
S/S-PASCAL NATIVE CODE ONLY	\$ 295.00
S/S-PASCAL DEMO DISCETTE (& MANUAL)	\$ 30.00

(Cdn. \$ in Canada, U.S. \$ outside Canada)

DEALER INQUIRIES WELCOME

P. O. Box 197  
Armdale, N.S.  
Canada B3L 4J9

**SCOTIA**  
**SOFTWARE**

(902)  
425-3879

## News and Speculation About Personal Computing

Conducted by Sol Libes

### Random Rumors:

Motorola's research-and-development group is rumored to be progressing nicely with a new 32-bit microprocessor design, and information on its specifications is being leaked. It will have a 4-gigabyte (4-billion-byte) direct-address range, a memory cache to increase throughput, and new instructions such as bit, field, and block moves; it will support ASCII (American Standard Code for Information Interchange) and bit-field data types. The device itself will be composed of 120,000 transistors and will consume 3/4 watt of power. Motorola is expected to start providing samples of the device before the end of next year. . . . Micropro is reportedly working on a full-color version of its Wordstar word-processor software for the IBM Personal Computer; the new version may run under MS-DOS. . . . Epson is expected to officially start shipping its personal computer system to dealers this month. . . . Wang Laboratories, the well-known word-processor manufacturer, is said to be readying an entry into the personal computer market.

### Sinclair Does It Again!

Clive Sinclair, the Englishman who shook up the microcomputer industry with the ZX80 and ZX81, is doing it again, namely, undercutting his competition. In England Sinclair Research Ltd. has introduced a new machine called the ZX Spectrum with a selling price equivalent to

about \$194. The machine sets a new high in its performance/price ratio that will shake up competitors such as Radio Shack, Atari, Commodore, and TI (Texas Instruments). It offers color, high-resolution graphics, sound generation, and more. The machine is an addition to the Sinclair computer line, so the current ZX81 will remain in production (in fact, its production is being increased to 150,000 a month). Do not expect the ZX Spectrum to become available in the United States until year-end, and even then it will be available by mail order only.

The new machine, which is about the same size as its predecessors, offers a keyboard with real keys, 16K bytes of memory (for an additional \$60 you can have a total of 48K bytes), and later this year Sinclair will introduce a 3-inch Microdrive (100K bytes storage per disk; 8 drives maximum) for less than \$80 per drive. Also expect a \$30 RS-232C interface for this machine; a small printer is already available.

The BASIC, which resides in ROM (read-only memory), is an extended version with full math, transcendental functions, and array-, string-, and graphics-handling capability. The keyboard and display offer both upper- and lowercase characters, and ASCII is used (there are 191 legends on 40 keys). The display format is 32 characters by 24 lines, with graphics resolution at 256 by 192 pixels, 8 colors, and features such as bright, flash, inverse, overprint, and user-defined characters.

With the upgrading of its machines to include larger memory, uppercase and lowercase, disk drives, and RS-232C, Sinclair is gradually shifting its focus from hobbyists to business users: people who use spreadsheets and other business software and are able to afford video terminals. When Sinclair introduces its flat-screen display, watch out!

**IBM Doings:** IBM has finally begun expanding its independent dealer organization; in June IBM appointed 16 independent computer-retailing operations, with a total of 62 outlets, as authorized IBM Personal Computer dealers. IBM is beginning to feel competitive pressure from suppliers of plug-compatible products. The result is that the company has dropped the price of its printer from \$755 to \$555 and that of its disk drive from \$570 to \$450.

IBM has also eliminated the ceiling on royalties from its contracts with independent software suppliers. The previous contract held a supplier's earnings to a maximum of \$100,000, thus discouraging many software developers. Under the new terms, percentages, advances, and duration of payment will be individually determined based on the program distributed, its documentation, and relevant business and technical factors. There will be an initial simple contract signed when a program is submitted for

evaluation by IBM, and a second contract will then be offered if and when the program is found acceptable for distribution by IBM.

Phase One Systems, Oakland, California, claims to have adapted its Oasis-16 multiuser operating system to run on the IBM Personal Computer and support up to three users. The firm claims that it is fully compatible with its Z80 version and that there are already over 400 business-application programs, written primarily in BASIC, available for it. The system allows private and shared files, with automatic record- and file-locking and optional password- and privilege-level protection. The system requires at least 128K bytes of memory and a 5-megabyte hard-disk system.

Telesoft, San Diego, has introduced an Ada compiler for the IBM Personal Computer. It provides a subset of Ada and utilizes the firm's proprietary ROS operating system.

IBM's Cambridge Scientific Center, Cambridge, Massachusetts, has disclosed that it is working on a research project to develop an easy-to-use, real-time editor-formatter, called Polite, similar to Xerox's Smalltalk operating system and language. It will also handle documents, images, data, graphics, and handwriting.

### Apple Happenings:

Apple Computer Inc. has filed suit against Franklin Computer Corporation of Pennsauken, New Jersey.

Apple alleges patent and copyright infringement by Franklin in designing its Ace-100 computer, introduced late last year. Specifically, Apple charges the company with copying Apple II programs on disk and in ROM.

Apple has also terminated its distributor in Japan and will set up its own marketing subsidiary in Tokyo. Apple reports that its sales volume in Japan doubled from fiscal year 1980 to fiscal year 1981.

Apple is rumored to be working on printers that use ink-jet and laser technologies at its accessory-products division in Garden Grove, California. Apple hopes to bring out printers using these technologies at prices substantially lower than those of other such printers. Apple is also believed to be working on a small flat-screen display at the same facility.

According to the police in Cupertino, California, several Apple employees allegedly helped direct the theft of \$1 million worth of Apple III computers in less than a year. Five people have already been arrested. According to the police, the allegedly stolen computers retail for about \$4500 and were sold for \$900, mostly to businesses.

**To Copy or Not to Copy:** Suppliers of Apple software, in an attempt to protect their copyrighted programs, use a number of techniques to prevent copying. This has encouraged software suppliers to sell "copying" software. Notable examples are the Locksmith and Nibbles Away 2 programs. No software supplier has yet devised an unbreakable software coding system.

Locksmith and Nibbles

Away 2 analyze the bit patterns and methods of encryption used on the disk to be copied and copy the bytes sequentially into the computer's memory and from there onto a new disk. It is claimed that over 15,000 copies of Locksmith have been sold since it was introduced in January 1981. It's worth noting that both Locksmith and Nibbles Away 2 use software protection against copying.

As yet no software supplier has taken the producers of Locksmith and other such programs to court. This is probably because the U.S. Copyright Act allows users to copy programs "for archival purposes only." And so far, unlike the record industry, no significant pirating for profit has developed.

Some software vendors require purchasers to sign a licensing agreement under which purchasers may be penalized if the vendor discovers an unauthorized copy of the software bearing the serial number of the purchaser's copy. Vendors have found that the combination of encryption and penalty clauses often has a negative effect on sales; hence some companies, including Apple Computer Inc., have given up on copyright protection.

Although copying by hobbyists has long been recognized as a problem, the copying that disturbs vendors the most is the copying done outside of the home. For example, a program vendor will find that a company or school may have tens or even hundreds of personal computers but buys only one copy of an application program and makes tens or hundreds of copies, one for use on each machine. Usually the purchaser has bought all these systems to run a specific application software program. But the software

## If You Have A Printer

You need our PRINTER OPTIMIZER. We have two gripes with computer printers: one, no matter how fast they print they're much slower than a computer. So here you are with all this processing speed, sitting there waiting for your printer to finish. Two, almost all printers offer a bunch of features like various type sizes, forms control, graphics, enlarged character sets, etc. - but how are you supposed to access these features? Oh sure, the printer manual says: "print an ESC character followed by a CONTROL "K" followed by a three digit value equal to the desired page length...", but how do you do this in the middle of your spreadsheet program? And how do you access all those extra symbols and graphics with a puny half-ASCII keyboard?



Before Mediamix grew into Applied Creative Technology Inc.,

the idea people there decided to develop the Cuisinart<sup>®</sup> of the computer industry - a "magic box" that features 64,000 to 256,000 characters of spooling printer buffer, total character retranslation capability including macros, a keyboard that lets you directly select complete printer control sequences with the ease of a pushbutton car radio, adapts serial printers to parallel computers and visa versa, plus many more imaginative features. So many useful features that regardless of the printer you own - our PRINTER OPTIMIZER will bring your printer "up to speed" with the rest of your system and let you take full advantage of it.

## If You Need A Letter Quality Printer



Consider our affordable alternative. For those of you who did not see the review of our product in the July issue of BYTE, we produce a little white box that converts an IBM Electronic Typewriter into a high quality Serial or Parallel computer printer. And now our ET1<sup>2</sup> (Electronic Typewriter Intelligent Interface) attaches to other brands of electronic typewriters. There are a number of arguments in favor of choosing this route over a mere computer printer and we have a brochure on the subject that you should read.

We apply technology creatively, and you'll find that not only can we communicate the results to you, but each product is better than anything else like it on the market. Call 1-800-433-5373 and we'll send you more information about our company and our products.

# APPLIED CREATIVE TECHNOLOGY, INC.

2723 Avenue E East, Suite 717  
Arlington, Texas 76011  
(817)-261-6905  
(800)-433-5373

company, who invested heavily in developing the program, feels that it receives a very small reward for its efforts while the hardware suppliers garner the real profits. Most software vendors specify that their software license is good only for use on a single machine and that additional licenses must be purchased for each machine the software is used on. However, few software purchasers abide by these terms.

**Word Processing and Office Automation:**

Word-processing programs are being greatly improved in their abilities to create, edit, and print text. Even more important are the features being added that will allow users to efficiently manage the office of the future. These features include the ability to store, copy, and merge documents; integrate variable and preformatted text; and perform mathematics, graphics, mailing, filing, appointment scheduling, and security-sensitive work.

Improved editing functions include automatic hyphenation

of words and operations that allow blocks of text to be copied, moved, deleted, printed, and written to a disk file. Several new word-processing programs allow linking and merging files to build boilerplate documents such as form letters. Printing enhancements include such features as optional automatic page headings and numbering, in Roman or Arabic numerals, in any location on the page or alternating between right- and left-hand corners for book-style formats. Some programs also allow the printing of partial, single, and multiple documents, often while editing another document. Another new feature is the placing of variable fields in documents and the filling of the fields automatically from a disk file or manually from the keyboard to personalize letters. Thus, the modern word-processor program may be told to recognize a zip code and automatically insert a phrase directed to people in that particular area.

More and more of the newer word-processor packages also include Visicalc-type functions, automatic in-

dex and table-of-contents generators, and spelling and syntax checkers and correctors. Features such as business graphics, phone index, appointment calendar, and card-file functions are being added. Some are also connected to a host network for electronic mail and accessing of document libraries with password protection. All of these features are leading the way from word processing to the office automation of the future.

**DEC Unveils Personal Computer Systems:**

"Better late than never" seems to be the DEC (Digital Equipment Corporation) maxim. Following in the footsteps of IBM and Xerox, the company has finally brought out four personal computer systems (described in the June 1982 BYTE Editorial), ranging in base price from \$3495 to \$4995: the Rainbow 100, the DECmate II, and the Professional 325 and 350. All use the same basic cabinetry except the 350, which has a larger box to house an internal Winchester-technology

hard-disk drive. The Rainbow 100 is basically a dual-processor 8088/Z80 system that will run CP/M, MS-DOS, and Pascal (the UCSD p-System). The DECmate II is a low-cost version of its PDP-8-based word-processor system. Its Professional models are 16-bit computers and use the P/OS operating system, derived from DEC's PDP-11 operating system. Options for the Professional systems will include Ethernet and DECnet support and plug-in CP/M cards.

The DEC systems will be sold through Computerland, Hamilton/Avnet, and DEC retail outlets. DEC currently has 25 outlets; it opened 27 outlets 3 years ago and then closed 2 of them after the first year. It is rumored that these DEC retail stores have yet to show a profit. Considering that Computerland stores already carry virtually every popular business-oriented personal computer system (e.g., IBM, Apple, Osborne, Fortune, etc.), and that DEC's personal systems do not offer anything new, DEC may have an uphill battle in entering the personal computer market.

**T.H.E. SMART TERMINAL<sup>®</sup>**



Software that turns your Atari 400 or 800 into a real smart terminal. Send and receive data from all popular data services. Works with cassette or disk for upload/download. 16K min. Available at Atari Dealers Worldwide or directly from Binary. VISA/MC/AMEX/COD/CHECK. Cassette \$49.95 Disk \$49.95 add \$2.50 P & H U.S., \$5.00 overseas.

**BINARY<sup>™</sup>**  
Computer Software  
3237 Woodward Ave.  
Berkley, MI 48072  
(313) 548-0533

BINARY CORPORATION

Circle 51 on Inquiry card.

 **BASF FlexyDisks<sup>®</sup>**

**5 1/4"**  
Specify soft,  
10 or 16 sector

	Price/10	Price/100
1 sided/double density	\$20.00	\$185.00
2 sided/double density	34.50	325.00

**8"** Specify soft  
or 32 sector

	Price/10	Price/100
1 side/single density	\$21.00	\$195.00
1 side/double density	29.50	275.00
2 sided/double density	34.50	325.00

Certified Check - Money Order - Personal Check  
Allow up to 2 weeks for personal checks to clear.  
Add \$1.50 to each order for U.P.S. shipping charges.

**DATA EXCHANGE, INC.**  
280 Dukas Parkway, P.O. Box 85  
Somerville, N.J. 08876 • (201) 725-6680

Circle 143 on Inquiry card.

 **ATARI**  
A Home Entertainment Company



800 (16K)	.....\$649.00
400 16K	.....279.00
400 YOURS to 32K or 48K	.....CALL
410 RECORDER	.....79.00
810 DISK DRIVE	.....449.00
850 INTERFACE	.....165.00
830 MODEM	.....149.00
825 PRINTER	.....375.00
481 ENTERTAINER KIT	.....79.00
484 COMMUNICATOR KIT	.....309.00
PRINTERS - Atari, Epson, Smith Corona	.....CALL

Prices subject to change without notice.  
Shipping extra. No tax out of state.  
Ca. residents add appropriate taxes.

WE ARE AN AUTHORIZED ATARI SALES AND SERVICE CENTER

**COMPUTERTIME, INC.**  
P.O. Box 216  
Kentfield, CA 94914  
CALL TOLL-FREE 800-227-2520  
In California 800-772-4064  
For product and price list: send \$2.00 for shipping.

Circle 120 on Inquiry card.

**Robotics News:** In Japan, Mitsubishi has introduced a robotics arm that can be connected to a micro-computer by way of a Centronics-type parallel port (not all the lines are used). Move Master software is provided that runs under CP/M. The cost in Japan is the equivalent of \$5000. The product is intended as a teaching aid and for sales promotion. There is no word on when it might be introduced in the United States. For information write: Mitsubishi, 2-3 Marunouchi 2-Chrome Chiyoda-Ku, Tokyo 100 Japan; or call: (218)2173.

**Find A Date With Your Computer:** The newest thing in computerized bulletin-board systems is the "Dial-A-Match" system. Several such systems are already in operation on personal computers connected to telephone lines and are operated as free public services (contributions are welcome). Although the software varies from system to system, the procedure is pretty much the same. Call the system via modem with your computer or a terminal. If it is your first time on the system you will be asked to complete a questionnaire. The system will then match you up with other callers and furnish you with information on the person or persons you are matched with. You can then exchange messages with anyone else on the system.

**Foreign Exchange:** My list of foreign computer bulletin-board systems is growing; here's an update: systems in England include Forum-80 Hull (04-828-59169), Forum-80 London

(01-747-3191), and Forum-80 Milton (09-085-66660). You might also try CBBS London (01-399-2136), Mailbox Liverpool (05-122-09733), or ACC (09-084-4262). In Holland there's Forum-80 (01-313-512-533), and based in Sweden are ABC-80 Stockholm (010-468-190522), University Research (010-468-23660; guest password: "66,66"), Elfa (010-468-7300706), and Tree Tradet (010-468-190522).

**Random News Bits:** Look for an R2D2-like robot kit to be introduced in the January Heathkit catalog. The 2-foot 2-inch 6808-based Hero 1 will have simulated eyes, ears, and a voice (using the Votrax SC-01 chip) and will be highly mobile. The kit will cost approximately \$1000; an optional \$100 manipulator (arm) will be available, as will a \$150 robotics course. . . .M.H.

Dataquest, a marketing research firm, reports that the Intel 8086 is still the leading 16-bit microprocessor, with an estimated 78% of the market, compared with 15% for the Motorola 68000 and 6.6% for the Zilog Z8000. Dataquest reports that last year 718,000 Intel 8086 processors were shipped, compared to 139,000 Motorola 68000s and 61,000 Zilog Z8000s. . . . Prices for single-board computers are dropping. Intel has dropped the price for its iSBC 88/25 (based on the Intel 8088) from \$1295 to \$790 (single unit) and \$520 (large quantity) to meet competition from DEC's Falcon 16-bit unit. . . . Texas Instruments will distribute 430 programs of Control Data Corporation's Plato software for its T1-99/4A home computer in 108 courses for kindergarten through high school levels. . . . Telegenix Corp., Cherry Hill, New Jersey, has in-

troduced a giant (measuring more than 10 feet diagonally) 80-character by 24-line neon planar-gas display panel and controller. Price is only \$52,500. . . . Perex Inc., San Jose, California, has introduced the first S-100 Ethernet interface (a two-board set). . . . Zilog has introduced an 8-user Unix-like system, called the System 8000, with a base price of \$13,000. . . . Vector Graphic Inc., Thousand Oaks, California, following in the footsteps of Apple, has terminated its supply contract with Computerland. Apparently sales slumped dramatically when Computerland took on the IBM Personal Computer, DEC, et al. Computerland, before these defections, carried 20 different computer lines. Vector Graphic stated that last year only 9% of its sales came through Com-

puterland. . . . Evotek Corp., Fremont, California, has announced a 5¼-inch Winchester-technology hard-disk drive with up to 50 megabytes of storage. . . . HP (Hewlett-Packard) has signed a \$30-million contract for Sony's new 3½-inch "micro-floppy," which has an unformatted storage capacity of 440K bytes. HP is the first company besides Sony to adopt the drive. . . . Hitachi Ltd., Tokyo, has unveiled an 8088-based system that it claims is compatible with the IBM Personal Computer.

**MAIL:** I receive a large number of letters each month as a result of this column. If you write to me and wish a response, please include a self-addressed, stamped envelope.

**Sol Libes**  
**POB 1192**  
**Mountainside, NJ 07092**

## New, Unique Products Alternate Energy, Telescopes, Optics, Weather, Magnets, Microscopes & More!

In One Giant FREE Catalog



### Biggest Catalog! Finest Quality!

Since 1941, thousands of engineers, craftsmen & hobbyists nationwide have been coming directly to the Edmund Scientific Catalog for quality products. . . fully guaranteed!

**FREE!** Simply fill in below, mail today, and your Edmund Scientific Catalog will be on its way to you.

Send FREE Catalog

Name \_\_\_\_\_

Address \_\_\_\_\_

City \_\_\_\_\_ State \_\_\_\_\_ Zip \_\_\_\_\_



**Edmund Scientific**

Dept. 8211 KH18 Edscorp Bldg.  
Barrington, N.J. 08007

No. 3484 ©1982 Edmund Scientific Co.

# Software Received

## Apple

**Adventure**, an implementation of the original adventure game. For the Apple II; floppy disk, \$10. Frontier Computing Inc., 666 North Main, POB 402, Logan, UT 84321.

**Automaniac System**, requiring an onboard clock card, this system can run a program or series of programs without supervision at a predetermined date and time. For the Apple II; floppy disk, \$100. Geegery Software Works, POB 8028, Des Moines, IA 50301.

**Chess Connection**, a telecomputing chess game that requires two computers equipped with modems for an interactive game. For the Apple II; floppy disk, \$35. Telephone Software Connection Inc., POB 6548, Torrance, CA 90504.

**Choplifter**, an arcade-type game. You control a helicopter in an effort to rescue hostages held captive in a foreign country. For the Apple II; floppy disk, \$34.95. Broderbund Software, Entertainment Software Division, 1938 Fourth St., San Rafael, CA 94901.

**Escape from Rungistan**, an adventure-type game. You must contend with cannibals, snakes, guerilla warriors, and a mad dictator's revenge while trying to escape from this interesting jungle nation. For the Apple II; floppy disk, \$29.95. Sirius Software Inc., 10364 Rockingham Dr., Sacramento, CA 95827.

**Fly Wars**, an arcade-type game. You maneuver a spider to trap the flies. For the Apple II; floppy disk, \$29.95. Sirius Software Inc. (see address above).

**Go-Moku**, a telecomputing version of the oriental board game go-moku. This program requires two computers equipped with modems for

an interactive game. For the Apple II; floppy disk, \$20. Telephone Software Connection Inc. (see address above).

**Graphics Processing System: Professional Version**, a graphics development system that lets you create, manipulate, and edit images. Includes zoom, two-dimensional rotation, and overlay functions. For the Apple II Plus; floppy disk, \$99.95. Stoneware Inc., 50 Belvedere St., San Rafael, CA 94901.

**Horse Racing Classic**, a highly detailed simulation of horse racing for one to nine players. You can check a horse's statistics, place bets, and watch the race. For the Apple II; floppy disk, \$36.95. Tasumi Software International Inc., 8 North Grosvenor Ave., Burnaby, British Columbia, V5B 1J2 Canada.

**Millionaire**, a stock-market game that lets you simulate investing in the stock market. You can examine company histories and buy stocks using a variety of options. For the Apple II; floppy disk, \$49.95. Micro-Z Applications, Suite 141, 22704 Ventura Blvd., Woodland Hills, CA 91364.

**Real Estate Models for the Eighties**, Visicalc templates for real-estate analysis. Using the Visicalc program, you can calculate figures for a wide variety of mortgages and amortization plans. For the Apple II and III; floppy disk, \$65. Commercial Software Systems, 7689 West Frost Dr., Littleton, CO 80123.

**Speed Reader**, a series of programs to help increase your reading speed. For the Apple II; floppy disk, \$70. Apple Computer Inc., 20525 Mariani Ave., Cupertino, CA 95014

**The Snapper**, an arcade-type game. You must travel around the grid collecting blots but avoiding the

Gamma Field and Whirlers. For the Apple II; floppy disk, \$32.95. Silicon Valley Systems, Suite 4, 1625 El Camino Real, Belmont, CA 94002.

**Statistics with Daisy**, a data-analysis and interactive-statistics package. You can sort, analyze, and plot data using simple, easy-to-learn commands. For the Apple II; floppy disk, \$79.95. Rainbow Computing Inc., 19517 Business Center Dr., Northridge, CA 91324.

**Super-Text**, a word-processing program that works with both 40- and 80-column screens. Instructions to make the shift key operational when used with a lowercase adapter are included. For the Apple II; floppy disk, \$175. Muse Software, 347 North Charles St., Baltimore, MD 21201.

**System/ASM 3A**, an assembly-language development system that features a two-pass assembler, full-screen editor, and disk-file management. For the Apple II Plus; floppy disk, \$35. Mike Piasek Co., 15401 Maple Park Dr. #11, Maple Heights, OH 44137.

**Tele-Gammon**, a telecomputing backgammon game. The program requires two computers equipped with modems for an interactive game. For the Apple II; floppy disk, \$35. Telephone Software Connection Inc. (see address above).

**Understand Yourself**, a series of nine tests to help you understand your feelings about marriage, sexual attitudes, and other aspects of your life. For the Apple II Plus; floppy disk, \$24.99. Huntington Computers, 1945 South Dairy Ave., POB 787, Corcoran, CA 93212.

**Wizardry: Knight of Diamonds**, the second scenario in the Wizardry game series. For the Apple II; floppy disk,

\$34.95. Sir-tech Software Inc., 6 Main St., Ogdensburg, NY 13669.

**Wizardry: Proving Ground of the Mad Overload**, a multiplayer fantasy and adventure game. You can develop your own characters in a Dungeon and Dragons-type game setting. For the Apple II; floppy disk, \$49.95. Sir-tech Software Inc. (see address above).

## Atari

**Alvin**, an arcade-type game. A reverse on the Missile Command format; you control the missiles trying to destroy a robot city. For the Atari 400 and 800; floppy disk or cassette, \$21.95 and \$17.95, respectively. Dynacomp Inc., 1427 Monroe Ave., Rochester, NY 14618.

**Frog Master**, a graphics program illustrating the use of operant conditioning. Through positive reinforcement, you train your frog to penetrate barriers and score goals for you. For the Atari 400 and 800; floppy disk or cassette, \$21.95 and \$17.95, respectively. Dynacomp Inc. (see address above).

**Golf Pro**, a simulation of a golf game using color and graphics. For the Atari 400 and 800; floppy disk or cassette, \$21.95 and \$17.95, respectively. Dynacomp Inc. (see address above).

**NYIndex**, a program that can store and plot up to three years of New York Stock Exchange information, from which you can determine the trend of the market based on past behavior. For the Atari 400 and 800; floppy disk, \$29.95. Dynacomp Inc. (see address above).

**Quintominoes**, a screen-based jigsaw game. For the Atari 400 or 800; floppy disk or cassette, \$16.95 and

\$12.95, respectively. Dyna-comp Inc. (see address above).

### Heath

**Space Odyssey I**, an arcade-type game. Retrieve your deep-space probes as you maneuver around or destroy asteroids, alien fighters, and mysterious objects. For the Heath H-8 and H-19 or H-89; floppy disk, \$21.50. Evryware, POB 60802, Sunnyvale, CA 94088.

**Y-Wing Fighter**, an arcade-type game. Pilot your fighter in a crucial mission to destroy the enemy's base. For the H-8 and H-19 or H-89; floppy disk, \$19.50. Evryware (see address above).

### IBM Personal Computer

**Millionaire** (see description above). For the IBM Personal Computer; floppy disk, \$49.95. Micro-Z Applications, Suite 141, 22704 Ventura Blvd., Woodland Hills, CA 91364.

**Real Estate Models for the Eighties** (see description above). For the IBM Personal Computer; floppy disk, \$65. Commercial Software Systems, 7689 West Frost Dr., Littleton, CO 80123.

**Speed Reader**, programs to help increase reading speed. For the IBM Personal Computer; floppy disk, \$74.95. Davidson and Associates, 6069 Groveoak Place #14, Rancho Palos Verdes, CA 90274.

### TRS-80

**ABE: Advanced BASIC Editor**, a BASIC programming editor that lets you list programs a page at a time, use global search and replace to modify a program, and write commands with a single key press. For the TRS-80 Model I; floppy disk, \$19.95. Interpro Corp., POB 4211, Manchester, NH 03108.

**Bounceoids**, an arcade-type game. Try to clear the

Bounceoid boulders from the screen while avoiding the Bounceoid creatures. For the TRS-80 Models I and III; floppy disk or cassette, \$19.95 and \$15.95, respectively. The Cornsoft Group, 6008 North Keystone Ave., Indianapolis, IN 46220.

**Co-Dir**, a cursor-oriented directory. Select programs from a directory by positioning the cursor next to the filename. For the TRS-80 Models I and III; floppy disk, \$19.95. Picotrin Technology, 3531 San Castle Blvd., Lantana, FL 33462.

**Copy-Tape**, a cassette tape-duplication program. For the TRS-80 Models I and III; cassette, \$11.95. Modtec, 4144 North Via Villas, Tucson, AZ 85719.

**IDM-X**, a database-management system. Features include a built-in sort and merge package and a fast key-access method for quick record access. For the TRS-80 Model II; 8-inch floppy disk, \$399. Micro Architect Inc., 96 Dothan St., Arlington, MA 02174.

**Interpro Flexible Mailing List**, a mailing-list program. You can custom program a mailing list to your exact specifications. Up to 1000 names per disk are possible. For the TRS-80 Models I and III; floppy disk, \$127. Interpro Corp. (see address above).

**Maxi CRAS: Check Register Accounting System**, a check writing and recording system. Using its menu-driven format, CRAS lets you set up income- and expense-account reports showing activity of one or more accounts over a period of time. For the TRS-80 Models I and III; floppy disk, \$99.95. Adventure International, 507 East St., POB 3435, Longwood, FL 32750.

**Personal File Manager**, a database-management program. Designed for everyday use, this program features format-free file structures

that accept almost any type of data. For the TRS-80 Color Computer; floppy disk, \$17.95. Home Information Systems, 4006 Ellicott St., Alexandria, VA 22304.

**Pocket Computer Primer**, companion software to the book of the same name. Includes a variety of programs for home and office use. For the TRS-80 Pocket Computer; cassette, \$8.95. Micro Text Publications Inc., Suite 27C, One Lincoln Plaza, New York, NY 10023.

**Pocket Magic**, companion software to the book of the same name. Includes a variety of simulations and games. For the TRS-80 Pocket Computer; cassette, \$8.95. Micro Text Publications Inc. (see address above).

**Records**, a student grades record-keeping system. This system can handle as many as 200 students and it provides

class rosters, evaluation scores, and final grades. For the TRS-80 Model III; floppy disk, \$69.95. Microsoftware Services, POB 776, Harrisonburg, VA 22801.

**Science and Engineering Sourcebook**, companion software to the book of the same name. Includes a variety of programs for professional use. For the TRS-80 Pocket Computer; cassette, \$8.95. Micro Text Publications Inc. (see address above).

**Spector of Kzirgla**, a graphics adventure game. Wind your way through the 13 floors of the maze as you slay monsters, collect treasures, fly a magic carpet, and even commit hari-kari if necessary. For the TRS-80 Color Computer; floppy disk or cassette, \$21.95. Rainbow Connection Software, 3514 6th Place NW, Rochester, MN 55901.

## AUTHORIZED SERVICE



Now you can get **FACTORY AUTHORIZED** service for your Commodore or Atari computer and peripherals at reasonable cost. Minimize your down time frustration and expense. Extended warranty available for most products, too!

## Micro Computer Service Center

**CALL 717-327-1450**  
477 E. Third St., Williamsport, PA 17701

# Disk-O-Tier

## STORES & PROTECTS 11 DISKETTES

Disk-O-Tier organizes and protects diskettes close at hand, and in minimum space.

Convenient, upright storage avoids "wipe-outs" caused by scratches, coffee spills, and cigarette ashes; plus, titles are easy to read.

Disk-O-Tier is molded of smoked, sturdy NAS plastic and safely files eleven 5 1/4" or 8" diskettes, in or out of jackets.

Priced at \$9.50 each, include \$2.00 postage or \$19.00 for twin-pack which includes postage. Ohio orders add 5 1/2%. Check or Money Order please. Non-U.S. orders add \$5.00.

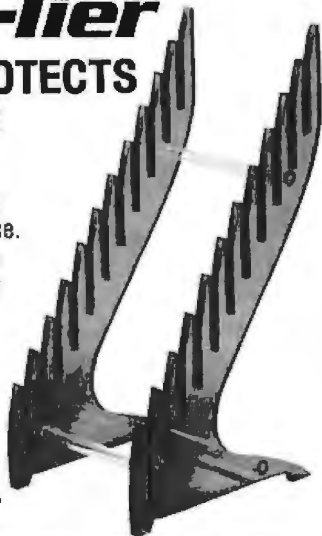

### ETS Center

Dept. 30 Box 651, 35026-A, Turtle Trail  
Willoughby, OH 44094 • (216) 946-8479

# SLUDER FOR ALL YOUR NEEDS

SOFTWARE, TERMINALS, PRINTERS, BOARDS  
SYSTEMS SHIPPED READY TO BOOT & RUN



#### BUDGET LINE

#### LUXURY LINE

6MHZ 8085/88, 64K, 801'S	\$2095	7/8MHZ 85/88, 64K,	\$4095
6MHZ 280, 64K, 801'S	2895	MPM 8-16, 256K, DT8'S	6645
8MHZ 8086, 80130, 64K	3450	10MHZ 8086, 80130	4495
10MHZ LIGHTNING 1, 128K	3195	10MHZ LIGHTNING 1	4095
8MHZ SEATTLE 86, MSDOS	3195	SEATTLE SYS II 128K	3135
MPM86 (TM) 8086, 256K, 8089	4350	SEATTLE SYS II, DRS	4785
MPM86, 512K, 10MB HD, 8086	8650	MPM 8-16, 256K, 10MB	9875
QUMES QN BUDGET ADD	200	QUMES STD EXCEPT SYS II	
GODBOU SYSTEM A, B, & C	AVAILABLE FROM SLUDER CALL		
GODBOU DISK 1 A&T	371	DISK II W/CP/M (TM)	596
GODBOU 8086 A&T	521	10MHZ 8086 (CSC)	638
INTERFACER 4 A&T	263	RAM 21 128K STATIC	1196
RAM 16 A&T 64K 8-16	488	CPU 8085/88 A&T	299
LOMAS RAM 47 128K CMOS	1194	LIGHTNING 1 8086 10M	520
LOMAS LDP72 DISK CONTR	220	CP/M 86 FOR LOMAS	195
LOMAS 128K DYNAMIC RAM	636	HAZITALL SUPPORT CRD	240
SEATTLE CPU SET, MSDOS	671	SEATTLE 64K 8-16 RAM	695
MORROW MICRO DECISION 1	949	MICRO DECIS. 2 DRS	1225
DMA DJ W/CP/M	366	MORROW 65K STATIC	404
DBASE II, WORDSTAR, SUPERCALC ONLY	\$895	OR W/SYSTEM	800
ALL CP/M & IBM PC SOFTWARE	SEATTLE RAM+192K	IBMPC	595
PRICES SUBJECT TO CHANGE	CP/M TM OF DIGITAL RESEARCH		
PO BOX 951, WESTMINSTER, CA	92483-0951	(714) 895-1746	

## Software Received

### Other Computers

Checkbook, Income Tax, and Budget Organizer, personal financial-management programs. For the ZX81; cassette, \$15. ZX-Panding Ltd., POB 25, Newton, NC 28658.

Flexfile, a database-management system that maintains a random-access database, including lists for mailing labels and accounting reports. For the PET/CBM; floppy disk, \$60. Total Control Software, 1038 Pine St., Philadelphia, PA 19107.

FORTH for Interact, a version of the FORTH language based on the FORTH Interest Group Model. For the Interact computer; cassette, \$12. Russell L. Schnapp, 8062 Gold Coast Dr., San Diego, CA 92126.

Improved Fixed Point Package, a replacement for Ithaca Intersystems fixed-point package. For the Ithaca Intersystems Pascal/Z; 8-inch floppy disk, \$50. Brom Microsystems Engineering Inc., POB 616, Winona, MN 55987.

Lattice 8086/8088 C Compiler, a compiler for the C language running under MS-DOS. For S-100-based systems; 8-inch floppy disk, \$500. Lifeboat Associates, 1651 Third Ave., New York, NY 10028.

Logical Analysis, a program to reduce any binary

state, multivariable equation to its minimum form. Written in BASIC; source code, \$5. Scientific Techniques, POB 8453, Greensboro, NC 27410.

MAC-00 and MAC-05, cross-assemblers for 6809-based systems. For SwTP (Southwest Technical Products) systems; 8-inch floppy disk, \$150 each. Rushmore Micro Systems, 622 East Tallent, Rapid City, SD 57701.

Real Estate Models for the Eighties (see description above). For the Hewlett-Packard HP-87 and HP-125; floppy disk, \$65. Commercial Software Systems, 7689 West Frost Dr., Littleton, CO 80123.

The Word Plus, an enhanced self-correcting spelling checker program. For CP/M-based systems; 8-inch floppy disk, \$150. Oasis Systems, 2765 Reynard Way, San Diego, CA 92103.

WP6502 Word Processing, a word-processing program. For the M/A-Com (Ohio Scientific) OS65D; 8-inch floppy disk, \$250. Dwo Quong Fok Lok Sow, 548 Broadway, New York, NY 10012.

WP6502 Word Processing (see description above). For the M/A-Com (Ohio Scientific) OS65U, 8-inch floppy disk, \$300. Dwo Quong Fok Lok Sow (see address above). ■

This is a list of software packages that have been received by BYTE Publications during the past month. The list is correct to the best of our knowledge, but it is not meant to be a full description of the product or the forms in which the product is available. In particular, some packages may be sold for several machines or in both cassette and floppy-disk format; the product listed here is the version received by BYTE Publications.

This is an all-inclusive list that makes no comment on the quality or usefulness of the software listed. We regret that we cannot review every software package we receive. Instead, this list is meant to be a monthly acknowledgment of these packages and the companies that sent them. All software received is considered to be on loan to BYTE and is returned to the manufacturer after a set period of time. Companies sending software packages should be sure to include the list price of the packages and (where appropriate) the alternate forms in which they are available.



# Clubs and Newsletters

## USUS(UK) Conference Report

Dr. J. Hoppe of ETH (Eidgenossische Technische Hochschule) in Zurich, Switzerland, was the guest speaker at a recent conference of the USUS(UK) (UCSD p-System Users Society). The conference included details on data-capture systems under UCSD and panel sessions on networking and educational software. Tony Addyman, committee chairperson of the ISO (International Standards Organization), spoke on ISO Standard Pascal. USUS(UK) membership details are available from Mark Woodman, Mathematics Faculty, The Open University, Walton Hall, Milton Keynes, MK76AA, United Kingdom; Tel: (0908) 74066.

## IBM PC Software Interchange

The IBM PC Software Interchange is a service that provides a means to obtain software inexpensively. Members can obtain most programs for \$5, plus handling. Program topics include mailing systems, electronic file sort, games, and finances. Each withdrawal requires an original program contribution. Membership fees are \$50 per year. For an informational packet, send \$3 to Miracle Computing, IBM PC Software Interchange, Dept. 10, 313 Clayton Court, Lawrence, KS 66044.

## PETs Strictly Allowed

*Strictly Commodore* is a monthly newsletter for Commodore PET, VIC-20, CBM, and SuperPET aficionados. It features articles with pro-

gramming hints and tips, evaluations of hardware and software, recreational and educational programs, news of happenings in the Commodore industry, information requested by readers, and a software exchange for owner-developed software. Subscription rates are \$18 per year. A sample issue is available for \$2. For more details, write *Strictly Commodore*, 47 Coachwood Place NW, Calgary, Alberta, T3H 1E1, Canada.

## Educational Software Evaluated

OECUP (Oklahoma Educational Computer Users Program) conducts evaluations of educational software by and for its members. Send a self-addressed, stamped envelope for application and further information to Richard V. Andree, OECUP, 601 Elm, Room 423, University of Oklahoma, Norman, OK 73019.

## Organization for Computer Consultants

The New York/New Jersey Chapter of the ICCA (Independent Computer Consultants Association) has more than 240 individuals on its mailing list. The ICCA is a nonprofit organization dedicated to promoting professionalism within the data-processing industry and supporting the independent computer consultant. ICCA has participated in the White House Conference on Small Businesses, and it serves the business community by providing a free referral service. Many ICCA members are qualified professionals on data-process-

ing subjects, and all abide by the ICCA Code of Ethics, which guarantees clients competence, integrity, objectivity, and confidentiality. The New York/New Jersey chapter is presently compiling an up-to-the-minute directory of its members. Further details are available from ICCA, POB 603, Middletown, NJ 07748, or call Harry A. Cozzi at (212) 430-6403 or (201) 862-4734.

## Osborne Group Blossoms in Ohio

The Central Ohio Osborne Users Group is a rapidly growing club in the Columbus area. Meetings are held at 7:30 p.m. on the second Monday of each month at the Ohio Institute of Technology, Alum Creek Dr., Columbus. The group is eager to learn every-

thing possible about the Osborne 1. A newsletter is being planned. Contact Newton Brokaw, Central Ohio Osborne Users Group, 2695 Donna Dr., Columbus, OH 43220, (614) 457-5716.

## Trilingual DAI Computer News

Each month the DAI-namic Personal Computer Users Club produces a 64-page trilingual magazine called *DAI-namic*. Written in Flemish, French, and English, it contains programs, letters to the editor, reviews of articles in other journals, graphics, tips, and information of interest to the DAI personal-computer user. For details, contact *DAI-namic*, Bruno Van Rompaey, Bovenbosstraat 4, 3044 Haasrode, Belgium. ■

# FREE <sup>56 page</sup> catalog

## Business Forms and Supplies for MICRO Computers

Standardized, continuous checks, invoices, statements and letterheads work with programs from over 200 software sources . . . or program forms with guides provided. Full color catalog also has stock tab paper, diskettes, other supplies.

- Quality products, low prices
- Small quantities
- No "handling charges"
- Money-Back Guarantee

Fast service by mail or PHONE TOLL FREE  
1 + 800-225-9550 (Mass. res. 1 + 800-922-8560)

NAME _____			
COMPANY _____			
STREET _____			
CITY, STATE and ZIP _____			
SOFTWARE BRAND	(To help us send correct info.)	PACKAGE #	<input type="checkbox"/> Do own programming
COMPUTER MAKE	MODEL		<input type="checkbox"/> Not Purchased
LINE OF BUSINESS			Number of Employees

**Neb's  
Computer Forms** CODE 11001

78 Hollis Street, Groton, Massachusetts 01471  
A division of New England Business Service, Inc.

# Books Received

*Advanced Baudot Radio Teletype for the TRS-80 Model I and Model III Micro-computer*, volume 5, Robert M. Richardson. Chautauqua, NY: Richcraft Engineering Ltd. (1 Wahned Industrial Park), 1982; 206 pages, 21 by 27 cm, softcover, ISBN 0-940972-06-9, \$20.

*Application Development Without Programmers*, James Martin. Englewood Cliffs, NJ: Prentice-Hall, 1982; 350 pages, 18 by 24.5 cm, hardcover, ISBN 0-13-038943-9, \$32.50.

*BASIC Faster and Better & Other Mysteries*, Lewis Rosenfelder. Upland, CA: IJG Computer Services, 1981; 288 pages, 21 by 27.5 cm, softcover, ISBN 0-936200-03-0, \$29.95.

*CAI Sourcebook*, Robert L. Burke. Englewood Cliffs, NJ: Prentice-Hall, 1982; 206 pages, 15.5 by 23.5 cm, hard-

cover, ISBN 0-13-110155-2, \$14.95.

*Computers and Computing. An Introduction Through BASIC*, Neill Graham. St. Paul, MN: West Publishing, 1982; 387 pages, 18 by 24 cm, softcover, ISBN 0-8299-0382-8, \$17.95. *Instructor's Manual to Accompany Computers and Computing*, 100 pages, 18 by 24.3 cm, softcover, ISBN 0-314-63242-5. Available to instructors free of charge.

*Computers That Think: The Search of Artificial Intelligence*, Margaret O. Hyde. Hillside, NJ: Enslow Publishers (POB 77), 1982; 126 pages, 14.9 by 24 cm, softcover, ISBN 0-89490-079-X, \$4.95.

*Data Entry Without Key-punching*, Martin D. Sorin. Lexington, MA: Lexington Books, 1982; 270 pages, 16.5

by 23.5 cm, hardcover, ISBN 0-669-02803-7, \$27.95.

*Design and Strategy for Corporate Information Services, MIS Long-Range Planning*, Larry E. Long. Englewood Cliffs, NJ: Prentice-Hall, 1982; 18 by 24.5 cm, hardcover, 180 pages, ISBN 0-13-201707-5, \$25.

*Exploring the World of Computers*, Donald D. Spencer. Ormond Beach, FL: Camelot Publishing, 1982; 102 pages, 15.3 by 22.9 cm, softcover, ISBN 0-89218-054-4, \$5.95.

*Hello, Mr Chips! Computer Jokes and Riddles*, Ann Bishop. New York: Lodestar Books, 1982; 64 pages, 15.2 by 23 cm, softcover, ISBN 0-525-66782-2, \$3.95.

*Information Systems Concepts for Management*, 2nd edition, Henry C. Lucas, Jr. New York: McGraw-Hill, 1982; 512 pages, 17 by 24.5 cm, hardcover, ISBN 0-07-038924-1, \$25.95.

*Inside CP/M: A Guide for Users and Programmers*, David E. Cortesi. New York: Holt, Rinehart, & Winston, 1982; 571 pages, 19 by 23.5 cm, softcover, ISBN 0-03-059558-4, \$22.95.

*Introduction to Business Data Processing*, 2nd edition, Lawrence S. Orilia. New York: McGraw-Hill, 1982; 683 pages, 19 by 24 cm, hardcover, ISBN 0-07-047835-X, \$21.95.

*Introduction to Microcomputers*, Erik Dagless and

David Aspinall. Rockville, MD: Computer Science Press, 1982; 233 pages, 15.5 by 23.5 cm, hardcover, ISBN 0-914894-25-0, \$19.95.

*Microcomputer Coloring Book*, Donald D. Spencer. Ormond Beach, FL: Camelot Publishing, 1982; 32 pages, 21.5 by 28 cm, softcover, ISBN 0-89218-052-8, \$2.90.

*Picture This: An Introduction to Computer Graphics for Kids of All Ages*, David D. Thornburg. Reading, MA: Addison-Wesley, 1982; 224 pages, 21.5 by 28 cm, spiral bound, ISBN 0-201-07768-X, \$14.95.

*Software and Its Development*, Joseph M. Fox. Englewood Cliffs, NJ: Prentice-Hall, 1982; 299 pages, 15.5 by 25.5 cm, hardcover, ISBN 0-13-822098-0, \$23.95.

*The Third Book of Ohio Scientific*, S. Roberts. Pomona, CA: Elcomp Publishing (POB 1194), 1982; 127 pages, 13.5 by 24 cm, softcover, ISBN 3-921682-77-0, \$7.95.

*What Computers Can Do*, 2nd edition, Donald D. Spencer. Ormond Beach, FL: Camelot Publishing, 1982; 368 pages, 15 by 23 cm, softcover, ISBN 0-89218-043-9, \$12.95.

*The Word Processing Book, A Short Course in Computer Literacy*, Peter McWilliams. Los Angeles, CA: Prelude Press, 1982; 235 pages, 15 by 22.5 cm, softcover, ISBN 0-931580-98-7, \$8.95. ■

## PRINTERS/SOFTWARE EXPANSION BOARDS

### PRINTERS

ADS-8001 .....	\$485.00
or C. ITOH 8510A .....	\$20.00
Dot Matrix Printers. Both printers have identical specs	
120 CPS w/Graphics, tractor and friction feed.	
C. ITOH 1550 (PRO WRITER II) Parallel interface .....	\$800.00
Parallel/serial combination .....	850.00
120 cps 15" wide carriage All other same as 8510A.	
C. ITOH F10/40 .....	\$1,550.00
Daisy wheel 40 cps	
Grappier .....	\$140.00

### DIGITAL PLOTTERS/ DIGITIZERS

#### HOUSTON INSTRUMENT HIPLLOT

DMP-3 .....	\$1,177.00
DMP-4 .....	1,262.00
DMP-6 .....	1,687.00
DMP-7 .....	1,857.00

#### PEN EXCHANGE KIT

DMP-442 6 Pen .....	\$356.00
DMP-593 8 Pen .....	456.00
HIPAD DT-11 .....	701.00
HIPAD DT-11A .....	723.00

#### STROBE

Strobe Plot .....	\$749.00
-------------------	----------



MICRO DATA TEK

A Division of International Antex, Inc.  
2630 California Street, Mountain View,  
California 94040 (415) 941-7914

### IBM PC

<b>256K RAM Expansion Card</b> (ADS-5001) expandable with 64K interval	
w/64K RAM on board .....	\$275.00
w/128K .....	425.00
w/192K .....	575.00
w/256K .....	725.00
<b>Disk Drive-Double sided/ double density .....</b>	
Single sided/double density .....	350.00
WordStar .....	297.00
MailMerge .....	90.00
Visicalc/256K .....	220.00
SuperCalc .....	220.00

### MICROPRO SOFTWARE

	CP/M	Apple
WordStar	\$297.00	\$225.00
MailMerge	90.00	75.00
SpellStar	150.00	120.00
DataStar	210.00	177.00
SuperSort I	150.00	120.00
CalcStar	177.00	117.00

### TERMINAL

BMC Green Terminal .....	\$105.00
--------------------------	----------

### APPLE BOARDS

16K RAM Card .....	\$75.00
Versacard .....	175.00
PRT-1 Parallel Int. ....	60.00
Smarterm .....	248.00
Z-Card .....	220.00

Showroom Hours: 8:30 to 5:30  
Saturday, 10:00 to 3:00

This is a list of books received at BYTE Publications during this past month. Although the list is not meant to be exhaustive, its purpose is to acquaint BYTE readers with recently published titles in computer science and related fields. We regret that we cannot review or comment on all the books we receive; instead, this list is meant to be a monthly acknowledgment of these books and the publishers who sent them.

## Putting Stock In Computers

Dear Steve,

I would like to use a computer for stock-market information. What software is available?

In addition to a list of stocks of my choice, I need to receive from a database charts of certain stocks that have outperformed others; e.g., the percentage of winners of the week as published in *Barron's*. I wish to be able to get a listing of certain stocks, for example:

- high cash
- high book value
- breakout of sideways movements

I may need to access up to 500 stocks each week and maintain a three-year log of historical data. Also, all disks must be on-line for automatic operation.

I would also like to have the ability to do general ledgers and to prepare W-2 forms—I have no payroll as such. My computer must function as a word processor, and I need a dot-matrix printer for utility copies of charts and correspondence-quality type for letters.

R. Miller  
Brooklyn, NY

*The Apple II computer will provide the necessary graphics, and a program called Market Charter will provide the rest. The Market Charter gives you:*

- high and low close bar charts
- trendlines, resistance lines, etc.
- volume charts with average volume
- hard copy of charts and data
- weekly and daily stock histories, etc.

*An updated version, to be out shortly, will include mov-*

*ing averages and allow an 80-stock, 100-week database. The program can link to a wire service via a modem.*

*This program is designed for technical analysts but is user-oriented.*

*Market Charter costs \$250 and is available from RTR Software Inc., 1147 Baltimore Dr., El Paso, TX 79902, (915) 544-4397. . . Steve*

## Basic Questions

Dear Steve,

I'm presently familiarizing myself with personal computers through a local school. Some basics have struck home, but I was wondering if you could answer some questions I have.

Do you know of an elaborate form of Visicalc or Visifile that runs on the Wang word processor? If so, can it be used to evaluate incredible amounts of information—by incredible I mean well beyond the capacity of the Apple II's Visicalc? The Wang uses hard-disk drives as well as 8-inch floppy-disk drives, but a Cromemco system with 5¼-inch disk drives is available to me.

Is there a forecasting and budgeting program available that could be used in developing scenarios for more effective planning to prevent or minimize large cash surpluses that result from trying to do a full year's work in six months?

What software is available for facility maintenance, planning, and monitoring timber management, including writing reports such as environmental impact statements, energy conservation, and road development?

How far away is the technology for equipment, similar to a stereoscope, that would scan two aerial photos

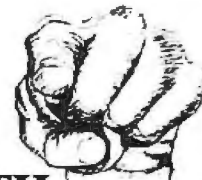

## Go FORTH and Prosper

With Timin FORTH, the unusually fast, elegant and versatile superset of FIG FORTH.

Lifeboat Associates offers this powerful, threaded, interpretive and structured language including a memory resident operating system, text editor, assembler and debugger. This extended FORTH is also enhanced by:

- a visual screen editor with string search and replace
- CP/M-80 file format compatibility
- many additional FORTH words
- array handling (implemented in machine code)
- FORTH assembler for 8080/Z80™ machine instructions
- full floating-point capability

Use this complete interactive software development system to slash software development time and shrink system memory requirements.

For more information about Timin FORTH or any of the other 200+ software packages available for use in professional, personal, and programming environments under SB-80™ or other CP/M®-80 compatible operating systems, IBM PC DOS, or MST™-DOS (SB-86) contact:

Lifeboat Associates, 1651 Third Avenue, NY, NY 10028. (212) 860-0300. TWX: 710-581-2524 (LBSOFT NYK); Telex: 640693 (LBSOFT NYK).

SB-80, SB-86, trademarks Lifeboat Associates  
MS, trademark Microsoft, Inc.  
Z80, trademark Zilog, Inc.  
CP/M, registered trademark Digital Research, Inc.  
Copyright ©1982, by Lifeboat Associates

2024

## S-100 SYSTEM DESIGNERS

### NEW TARBELL CACHE MEMORY SYSTEM

Increase floppy disk system speed from 2 to 5 times using our new CACHE-C CP/M®. This will only work with the Tarbell CPU/IO board and the Tarbell Double Density Floppy Disk Interface, so we have a combination package available.

This package includes the following:

- CPU/IO board with 4 Mhz Z-80A, 2 RS232 serial ports with full handshaking, timer, and special memory management circuitry.
- Double Density Floppy Disk Interface with boot ROM, Direct Memory Access and extended memory addressing.
- CP/M 2.2 on single density disk with manuals
- New CACHE-C CP/M 2.2 on double density disk. This system keeps up to 64k of most recently used 512-byte sectors in extended address memory.

All for \$945 list (25-35% dealer discounts)

Tarbell Electronics, 950 Dovlen Place, Suite B  
Carson, California 90746 (213) 538-4251, 2254

CP/M is a registered trademark of Digital Research

and tell the user available board footage of lumber, timber types, and road locations? Upon receiving such information as current road-development costs, timber prices, and environmental costs, could this equipment literally design and size the timber-sale cost effectively?

Thanks.  
Michael Montgomery  
Petersburg, AK

*I will try to answer your questions in the order presented:*

*Visicalc is a product of Visicorp (2895 Zanker Rd., San Jose, CA 95134, (408) 946-9000), which you should contact to see what computers can use its programs. If there has been sufficient demand, Visicorp may have a version available for Wang computers.*

*Apple Computer has introduced a program called APM (Apple Project Management) that should have the facilities you need. Check a computer store or contact Apple Computer Inc., 20525 Mariani Ave., Cupertino, CA 95014, (800) 538-9696; in California, (408) 996-1010.*

*As for facility maintenance software, your best bet would be a software house that handles CP/M-based software such as Lifeboat Associates, 1651 Third Ave., New York, NY 10028, (212) 860-0300 or Winterhalter & Associates Inc., 313 North First St., Ann Arbor, MI 48103, (313) 662-2002.*

*The U.S. Government has launched a number of satellites that are able to detect mineral deposits, water, and probably fish, wildlife, and vegetation. For further infor-*

*mation, write to the Department of the Interior, C St., Washington, DC 20240.  
... Steve*

**Portable Terminals**

Dear Steve,  
I'm looking for a way to buy or build a smart remote terminal that I can carry with me and use to communicate with larger computers. I'd like to be able to compose, edit, and format my data before sending it along the telephone lines. You once talked about making such a thing with the Sinclair ZX80. Do you think the Sinclair and a Sony 3-inch disk drive would do the trick? I'm not much of a circuit builder, so this sounds better than starting from scratch.

Ben L. Geer  
Miami, FL

*Using the Sinclair ZX80 as a portable terminal with a modem and a small TV is entirely possible, but adding a disk drive is no small project (unless someone creates a disk interface).*

*Several good briefcase terminals are available—e.g., Matsushita, Rockwell, and Texas Instruments—as well as a few briefcase computers.*

*If you must have a disk drive, one possible solution is to use the Osborne 1 portable computer. It comes with disk drive, disk operating system, various types of high-level language software, and a serial port. It is about the size of a small briefcase.*

*Whichever method you use must be a compromise of price and performance. The Sinclair is the less expensive choice, but the Osborne 1 (or similar) computer might be the only way to satisfy your objective with any reliability. . . . Steve*

**Apple Measuring Devices**

Dear Steve,  
Do you know how a thermistor can be plugged into the game port, or an A/D (analog-to-digital) converter board, to give temperature readouts on the Apple II? I want to measure carbon dioxide (CO<sub>2</sub>) gas in an air stream.  
Dan Bruhns  
Pine Bush, NY

*Measuring the quantity of CO<sub>2</sub> in a gas stream is considerably more involved than measuring either its temperature or its velocity. For the former, most of the methods used are chemical in nature such as bubbling the CO<sub>2</sub>-containing air into a solution that will cause the precipitation of calcium carbonate, which can then be measured. If extreme accuracy is required, a gas chromatograph can be used.*

*Measuring velocity is somewhat easier. The method that you probably would want to use is based on thermal conductivity and called a hot-wire anemometer. This measurement is usually made by observing the change in temperature of a fine, heated wire that is conduction cooled by the gas or vapor. . . . Steve*

**Time to Take Readings**

Dear Steve,  
I have been following your design projects ever since they first appeared in BYTE. I have a Radio shack TRS-80 and would like to know of a relatively simple circuit to pick up the date and time signals transmitted by radio station WWVB from Boulder, Colorado, on 60 kHz.  
For a long time, I've been interested in connecting a

**SENECA ELECTRONICS  
SUPER DISCOUNTS TRS-80® AND OTHERS**



TRS-80®  
BELL & HOWELL™ (APPLE)™  
ATARI™  
VIC COMMODORE™  
and OTHERS...

TRS-80™ 16K MODEL III \$810.00  
TRS-80™ 64K MODEL II \$2995.00  
ATARI™ 800 W/16K \$650.00  
VIC-20™ HOME COMPUTER \$245.00  
ALL MACHINES COME WITH FULL  
MANUFACTURERS' WARRANTY!!

COMPUTER FURNITURE, PRINTERS, PERIPHERALS, YOU NAME IT, WE GOT IT, AT THE PRICE YOU WANT TO PAY. WE ACCEPT CERTIFIED CHECKS, MONEY ORDERS, VISA & MASTERCARD. SHIPPING CHARGES WILL BE ADDED TO CHARGE CARD ORDERS.

SENECA ELECTRONICS  
RD #1, HARMONY, PA 16037  
(412) 452-5654

real-time clock to my system so that I could couple it to my environmental telemetry sensors. I plan to bury 8 geothermal sensors spaced at 10 inches (25 cm) vertically and a ninth sensor for surface temperature. Over the course of a year, I should be able to gather enough temperature data to be able to intelligently calculate how much soil I will need over an underground home that I plan to build. By having the accurate date and time, I will know the latency of a surface temperature shift, and how it will affect the temperature at different depths.

Gary R. Casady  
Pinckney, MI

*Using date and time signals from WWVB as a real-time clock for your TRS-80 is certainly feasible, but it requires sophisticated equipment because of the slow rise times of the time codes. The transmitted signal must be phase-controlled to the UTC (Uni-*

*versal Coordinated Time) time scale and the receiver must have a very narrow bandwidth (0.01 to 0.001 Hz) to extract the VLF (very-low frequency) signal from the noise level in this frequency band (60 kHz).*

*Rather than use all of this equipment, I would recommend the "Timedate 80" from Alpha Products, 79-04 Jamaica Ave., Woodhaven, NY 11421, (800) 221-0916; in New York, (212) 296-5916. It's totally compatible with your TRS-80 and sells for only \$95, fully assembled and tested.*

*The accuracy of this unit is controlled by a quartz crystal and should be more than adequate for your application. From an advertisement, I can envision many other applications for this unit. . . . Steve*

### An Investment In Education

Dear Steve,  
My 12-year-old son has an

interest in programming. He learned BASIC II at local community colleges. His initial interest is in video games, and he has written some neat game programs.

I want to encourage his interest but cannot afford a decent microcomputer. I have an Atari Video Game system, television, and a data terminal (Texas Instruments "silent 700") that he can use. It appears all we need is memory and mass storage. Is there any device with such capability that can be integrated with this equipment? Frank Plona  
Collinsville, CT

*The Atari Video Game System does have a BASIC option that consists of a cartridge and a keypad. It is supposed to enable programming in BASIC, but I am not aware*

*of any storage device (i.e., cassette recorder) for it. It must be recognized that this system was designed as a game player and not as a programmable computer.*

*I would suggest that you look into one of the low-cost microcomputers on the market, such as the Commodore VIC-20, Atari 400, Radio Shack TRS-80 Color Computer, or the Sinclair ZX81.*

*With the exception of the \$100 ZX81, these units are in the \$300 to \$400 price range and feature a full BASIC language, graphics, memory, and a keyboard so that programming may be accomplished both easily and efficiently.*

*These units offer a lot of features for the money and represent a good investment in your son's education. . . . Steve*

In "Ask BYTE," Steve Ciarcia answers questions on any area of microcomputing. The most representative questions received each month will be answered and published. Do you have a nagging problem? Send your inquiry to:

Ask BYTE  
c/o Steve Ciarcia  
POB 582  
Glastonbury CT 06033

If you are a subscriber to The Source, send your questions by electronic mail or chat with Steve (TCE317) directly. Due to the high volume of inquiries, personal replies cannot be given. Be sure to include "Ask BYTE" in the address.

## BYTE's Bits

### Call for Papers

A call for papers on computers and computer applications in any area of interest to college and university instructors and administrative personnel has been issued by the California Educational Computing Consortium. The papers are to be delivered at the Seventh Western Educa-

tional Computing Conference to be held in San Francisco, California, during November 1983. Send two copies of your original paper to Professor Virginia Lashley, Coordinator of Instructional Computing, Glendale College, 1500 North Verdugo, Glendale, CA 91208. A deadline of March 1, 1983, has been imposed. ■

## DUAL THERMOMETER

For Apple II\*  
COMPLETE WITH SOFTWARE



- Display temperature, maximum, minimum and difference.
- Sound alarm for over/under temperature.
- Store data on disk or printer automatically.
- Display time with on-board timer.

- Up to 7 boards with 14 probes in one Apple\*.
- -55°C to 125°C range, 0.4° accuracy over most of range.
- Requires 48K Apple\* with Applesoft\* and disk.

**\$260.00**

Strawberry Tree Computers  
949 Cascade Drive  
Sunnyvale, Ca. 94087  
(408) 736-3083



If your dealer doesn't have it, call or write us at dept. A

\*TM of Apple Computer, Inc.

# Event Queue

## September 1982

### September

**Courses from Boeing Computer Services Company**, various sites throughout the U.S. Among the topics to be covered are programming languages and aids, operating systems facilities, and conversational systems. A complete catalog of courses, locations, and fees is available from Boeing Computer Services Co., Education and Training Division, POB 24346, Seattle, WA 98124, (206) 575-7700.

### September

**Professional Development Seminars**, various sites throughout the U.S. These seminars are presented by the Institute for Advanced Technology, a part of Control Data Corporation. Seminar topics include "Computer Operations Management," "Data and Site Security," and "Effective Management of Software Projects." Complete outlines can be obtained from the Registrar, Institute for Advanced Technology, Control Data Corp., 6003 Executive Blvd., Rockville, MD 20852. To register, call (800) 638-6590; in Maryland, (301) 468-8576. Information on in-house presentations is available from Pam Gallos at the address above.

### September-November

**Short Courses in High Technology**, Centennial College of Applied Arts and Technology, Scarborough, Ontario, Canada. Among the courses offered are "Logic to Microprocessors," "Assembly-Language Programming—Intel 8080/8085," and "Industrial Robots." Course fees range from \$30 to \$120. These ten-week courses will be held during evening hours. For further details, contact the Coordinator Technical Programs, Centennial College, POB 631,

Station A, Scarborough, Ontario M1K 5E9, Canada, (416) 439-3955.

### September-December

**Courses from Don White Consultants**, various sites throughout the U.S. and Canada. Among the courses being offered are "Interference Control: An Introduction to Electromagnetic Interference/Radio Frequency Interference/Electromagnetic Compatibility," "Electromagnetic Control in Electronic Data-Processing Equipment," and "Tempest-Design, Control, and Testing." Course fees range from \$675 to \$945. For complete details, contact Don White Consultants Inc., State Route 625, Gainesville, VA 22065, (703) 347-0030.

### September-December

**Courses from Fairchild Camera and Instrument Corporation**, Santa Clara, CA. Among the courses being offered are "F9445 Family Introduction," "Pascal for Microprocessors," and "F680X Microprocessor Family." For more information, contact Fairchild Camera and Instrument Corp., Education Center, 3420 Central Expressway, Santa Clara, CA 95051, (408) 773-2161.

### September-December

**IEEE Computer Society Conferences and Meetings**, various sites throughout the U.S., Europe, and Asia. Among the events scheduled are "Very Large-Scale Integration and Software Engineering Workshop," "The Annual Workshop on Computing to Aid the Handicapped," and "The 1982 Real-Time Systems Symposium." For a complete listing of conferences and meetings, contact the Executive Secretary, IEEE Computer Society, POB 639, Silver Spring, MD 20901, (301) 589-3386.

### September-December

**Information Management and Technology Seminars**, various sites throughout the U.S. Among the wide variety of seminars offered by Datamation Institute are "Distributed Systems: Concepts and Management Overview," "Management of Software Engineering: Lowering Costs, Boosting Productivity," and "Data-Processing Concepts for Management and Users." Registration fees range from \$595 to \$795, depending upon duration and the topic covered. For details, contact Ms. Joan Merrick, Datamation Institute Seminar Coordination Office, Suite 415, 850 Boylston St., Chestnut Hill, MA 02167, (617) 738-5020. For information on in-house presentations, contact Art Gutmann, Datamation Institute for Information Management and Technology, Seminar Coordination Office, Suite 803, 331 Madison Ave., New York, NY 10017, (212) 697-2361.

### September-December

**Intensive Seminars for Professional Development**, Worcester Polytechnic Institute campus and various sites in the New York City and Boston metropolitan areas. Some of the topics to be presented are "Project Management," "Leadership Skills and Management Tools for High-Technology Professionals," and "Microprocessors: Hardware, Software, and Applications." Fees range from \$495 to \$990. Complete details are available from Ms. Ginny Bazarian, Office of Continuing Education, Higgins House, Worcester Polytechnic Institute, Worcester, MA 01609, (617) 793-5517. For information on in-house seminars, call Robert J. Hall at (617) 793-5574.

### September-December

**Seminars of Interest to Women Professionals**, various sites around Boston, MA. This series of one- and two-day seminars is presented by Boston University Metropolitan College. Among the topics on the agenda are "Managing Word Processing to Increase Productivity and Profitability," "A Manager's Introduction to Computers and BASIC," and "Data Processing Fundamentals for Accounting and Financial Managers." The seminar fees are \$325 and \$495, depending on duration. For registration information, contact Ms. Joan Merrick, University Seminar Center, Suite 415, 850 Boylston St., Chestnut Hill, MA 02167, (617) 738-5020.

### September 12-15

**Design Engineering Technical Conference**, Keybridge Marriott, Washington, DC. For information on this conference, contact the American Society of Mechanical Engineers, United Engineering Center, 345 East 47th St., New York, NY 10017, (212) 644-7740.

### September 13

**Knowledge Engineering in the 1980s**, Chicago, IL. This executive briefing provides an overview of the power and potential of artificial intelligence. It is designed to introduce executives and senior technical personnel to the concepts of knowledge engineering and knowledge systems. Topics to be covered will assist participants in assessing the utility of knowledge engineering, pinpointing areas of impact, and outlining costs and strategies for initiating knowledge-engineering projects. The fee is \$750, which includes materials, luncheon, and a reception. For further information, contact Dina

Barr, Teknowledge, 151 University Ave., Palo Alto, CA 94301, (415) 327-6600.

September 13-14

**VLSI (Very Large Scale Integration) Packaging Workshop**, Gaithersburg, MD. This workshop is sponsored by the National Bureau of Standards and the IEEE (Institute of Electrical and Electronics Engineers). Contact George Harman, B310 Technology Building, National Bureau of Standards, Washington, DC 20234, (301) 921-3621.

September 13-15

**Advanced Electronic Data Processing Auditing Concepts**, Phoenix, AZ. This course is designed for experienced computer auditors. Topics to be studied include advanced computer systems control concepts and methods of evaluating controls and techniques for testing integrity and applications controls for online systems, database management systems, and distributed-processing networks. This course is presented by Coopers & Lybrand. Information is available from Marge Umlor, EDP Auditors Foundation, 373 South Schmale Rd., Carol Stream, IL 60187, (312) 682-1200.

September 13-15

**Hands-on Pascal Workshop**, San Diego, CA. This course will provide the opportunity to learn Pascal through hands-on experience on Apple Pascal systems. Topics to be addressed include coding the language, using structured programming techniques, developing portable and maintainable software, and implementing real-time software suitable for microcomputer and minicomputer applications. The course fee is \$695. For information, contact Ruth Dordick, Integrated Computer Systems, 3304 Pico

Blvd., POB 5339, Santa Monica, CA 90405, (800) 421-8166; in California, call (213) 450-2060.

September 13-16

**Microcomputers as Laboratory Instruments**, Cambridge, MA. This workshop is part of Technical Education Research Centers' (TERC's) Microcomputers in Education series. The cost is \$300. For a brochure, contact TERC, 8 Eliot St., Cambridge, MA 02138, (617) 547-3890.

September 13-17

**Computer Vision and Robotics**, University of Tennessee, Knoxville, TN. This course is intended for scientists, industrial managers, and instrumentation, control, quality control, reliability, electrical, mechanical, and other design engineers. It will introduce and survey the state of the art in the use of visually guided manipulators for industrial applications. The fee is \$625. Further information can be obtained from the Coordinator, Computer Vision and Robotics Course, Department of Electrical Engineering, University of Tennessee, Knoxville, TN 37996, (615) 974-3461.

September 13-17

**FORTH Fundamentals**, Belmont, CA. This course provides an introduction to the FORTH programming language sufficient to design and debug programs to solve real problems. Program design and documentation, FORTH arithmetic, control structures, and Meta-defining words are among the topics to be covered. The registration fee is \$395. Contact Inner Access Corp., POB 888, Belmont, CA 94002, (415) 591-8295.

September 13-24

**Computer Science at UCLA**, University of California, Los Angeles. Sponsored by the Continuing Education in Engi-

# \$495.

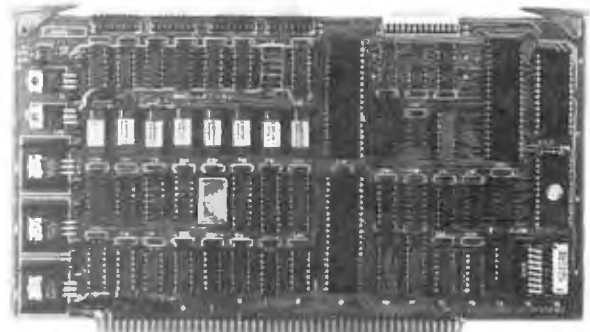

## SBC can be redundant!!

- Z80A 4MHz, 64K RAM, 2K ROM
- 2 serial, 2 parallel, 4 timer ports
- Bi-directional inter-processor channel
- Multi-processor architecture capability
- Redundant processor manipulation capability
- Matching double-density disc controller with SASI
- Application note for system configurations

**JC SYSTEMS** (415) 657-4215  
1075 Hiawatha Ct. Fremont, CA 94538

## TERMINALS FROM TRANSET

PURCHASE PLAN • 12-24 MONTH FULL OWNERSHIP PLAN • 36 MONTH LEASE PLAN

	DESCRIPTION	PURCHASE PRICE	12 MOS PER MONTH	24 MOS PER MONTH	36 MOS PER MONTH
<b>DEC</b>	LA34 DECwriter IV Forms Ctrl. ....	\$1,995	\$105	\$ 58	\$ 48
	LA100 Letter Printer RD. ....	1,995	190	106	72
	LA120 DECwriter III KSR. ....	2,295	220	122	83
	LA120 DECwriter III RD. ....	2,995	290	112	78
	VT100 Portable DECwriter. ....	2,950	290	155	108
	VT101 CRT DECscope. ....	1,595	152	80	61
	VT101 CRT DECscope. ....	1,195	115	67	43
	VT125 CRT Graphics. ....	3,295	318	185	119
	VT131 CRT DECscope. ....	1,745	167	93	63
	VT132 CRT DECscope. ....	1,995	190	106	72
VT18XAC Personal Computer Option	2,395	230	129	88	
<b>TEXAS INSTRUMENTS</b>	T1745 Portable Terminal. ....	1,595	153	85	58
	T1755 Bubble Memory Terminal. ....	2,595	249	138	93
	T1940 CRT. ....	1,195	173	96	65
	T1785 Portable KSR, 120 CPS. ....	2,395	230	128	86
<b>LEAR SIEGLER</b>	T1787 Portable KSR, 120 CPS. ....	2,845	273	152	102
	T1810 RD Printer. ....	1,895	182	90	61
	T1820 KSR Printer. ....	2,195	211	117	80
<b>DATAMEDIA</b>	ADM3A CRT Terminal. ....	595	57	34	22
	ADM5 CRT Terminal. ....	845	82	38	24
	ADM32 CRT Terminal. ....	1,165	112	65	42
<b>TELEVIDEO</b>	EXCEL 12 CRT Terminal. ....	1,595	153	85	58
	EXCEL 42 Smart Bullerred CRT. ....	995	96	54	36
	COLORSCAN 10 Color CRT. ....	3,195	307	171	116
<b>NEC SPINWRITER</b>	910 CRT Terminal. ....	650	62	36	24
	925 CRT Terminal. ....	850	82	46	31
	950 CRT Terminal. ....	1,075	103	57	39
<b>GENERAL ELECTRIC</b>	Letter Quality, 7715 RD. ....	2,895	278	154	104
	Letter Quality, 7725 KSR. ....	3,295	316	175	119
<b>EPSON</b>	2030 KSR Printer 30 CPS. ....	1,195	115	67	43
	2120 KSR Printer 120 CPS. ....	2,195	211	117	80
<b>TIMEPLEX</b>	MX-90 F T Printer. ....	745	71	42	27
	MX-100 Printer. ....	895	86	48	32
<b>TIMEPLEX</b>	ED400 4 Channel Stat Mux. ....	1,525	147	82	55
	ED800 8 Channel Stat Mux. ....	2,850	197	110	74

FULL OWNERSHIP AFTER 12 OR 24 MONTHS • 10% PURCHASE OPTION AFTER 36 MONTHS

### MICROCOMPUTERS

APPLE • COMMODORE • HP87 • DEC

### ACCESSORIES AND PERIPHERAL EQUIPMENT

ACOUSTIC COUPLERS • MODEMS • THERMAL PAPER • RIBBONS • INTERFALE MODULES • FLOPPY DISK UNITS



**TRANSET CORPORATION**  
1945 ROUTE 22 • UNION, N. J. 07083 • (201) 688-7800  
TWX 710-985 5485 800-526-4965 OUTSIDE N. J.

# UV EPROM ERASER

- ★ Erases over 15 EPROMS - 15 minutes erase time
- ★ Element life 7700 hours
- ★ Intensity: 12Ws 1/4cm² at 1"
- ★ Erases all UV EPROMS (2716, 2732, 2516, 2532, etc.)

**\$49.95\***

\*HOBBY MODEL



**INDUSTRIAL MODEL**  
QUV-T8/2N  
**\$68.95**

**WITH TIMER & SAFETY SWITCH**  
QUV-T8/2T  
**\$97.50**

**ABOVE 220VAC 50HZ**  
QUV-T8/2TE  
**\$109.50**

PRICE INCLUDES ALL PERSONALITY MODULES

**STAND ALONE RS-232 INTELLIGENT PROGRAMMER \$489.00**

PROGRAMS: 2508, 2516, 2532, 2716, 2732, 2732A, 2758, 8748, 8749

- ★ STAND ALONE, CRT, OR COMPUTER CONTROL
- ★ UPLOAD/DOWNLOAD IN MOTOROLA OR INTEL HEX FORMAT
- ★ MICROPROCESSOR BASED • 4 K INTERNAL RAM
- ★ 90 DAY PARTS & LABOR WARRANTY ON ALL PRODUCTS

- ★ GANG PROGRAMMER
- ★ 256A, 276A PERSONALITY MODULES

Soon to be released

PHONE ORDERS (305) 776-5870

TWX: 510-955-9496 • WE ACCEPT VISA, MC, CHECKS, C.O.D., MONEY ORDER

## LOGICAL DEVICES INC.

781 W. OAKLAND PARK BLVD. • FT. LAUDERDALE, FL 33311

ADD: \$4.00 SHIPPING \$2.00 C.O.D. CHARGES

## \$100 EPROM PROGRAMMER/16K MEMORY MODULE



- Programs, copies or verifies the most popular 5 volt EPROMS (2758, 2516, 2716, 2532, & 2732)
- Adjustable 25 volt on board supply.

- External programming console - Includes 24-pin ZIF socket
- Sockets also included for up to 8 memory chips (2716/2732 EPROMS or 2K X 8 NMOS Static RAMS)
- Memory addressable in 4K/2K windows
- Memory management - 4 memory chips may be independently enabled/disabled under program control
- 8-bit I/O port w/handshake
- Software - CP/M version on 8" disk, PET 2001 (requires S100 adapter) on cassette.

### \$100 PROTOTYPE MODULE



- Unique prototype module takes up only one computer slot
- Uses low cost W/W posts, and if desired, solder tail sockets.

- Wiring & components are on the same side
- Provisions for 3 voltage regulators - 5 volt regulator may be TO-3 or TO-220 case
- Any size integrated circuit on .300, .400, or .600 centers may be used
- Typical configurations - 36 16/14-pin IC's, or 4 40-pin & 28 16/14-pin IC's, or 1 40-pin & 4 24-pin & 14 20-pin & 14 16/14-pin IC's, etc.
- Also has provisions for: toggle switch, trimpot, & 2 50-pin ribbon cable headers
- Power & ground traces to each IC position
- Ample de-coupling provisions.

### PRICES

Prog/Mem Mod. \$195(kit)\$240(A&T)	Prototype (Pins) . . . . . \$35/M
EPROMS:2Kx8 (5V) . \$6.00(450NS)**	Software: CP/M version (8" diskette) . . . . . \$15.00
4Kx8 (5V) . . . \$16.00 (450NS)**	PET (specify ROMS) . . . . . \$8.00
RAMS 2Kx8 (5V) \$11.50 (150NS)**	Shipping & handling . . . . . \$2.00
Prototype (Board) . . . . . \$35.00	

CALIFORNIA RES. ADD 6% SALES TAX.  
PAYMENT: MONEY ORDER OR CHECK (ALLOW 10 DAYS TO CLEAR)  
\*\*WITH PURCHASE OF PROGRAMMING BOARD

### SIERRA COMPUTER PRODUCTS

3645 Gold Ridge Trail, Pollock Pines, CA 95726/(916)644-5932

## Event Queue

neering and Mathematics (CEEM), this UCLA Extension program is designed for engineers, managers, and other professionals needing a concentrated overview of an up-to-date, master's level computer-science curriculum. Participants may enroll in six minicourses from a total of 18. Each unit is based on a course presented by UCLA's Computer Science Department during regular academic sessions. Each course runs for one week, two hours per day, for a total of 10 lecture hours. Hands-on experience is not provided. The fee is \$1750 for the complete two-week program. Full details may be obtained from UCLA Extension, CEEM Special Programs, POB 24901, Los Angeles, CA 90024, (213) 825-5010.

September 14-17

**Applied Time Series Analysis**, North Lake Hilton Hotel, Atlanta, GA. For details, contact the Continuing Education Institute, Oliver's Carriage House, 5410 Leaf Treader Way, Columbia, MD 21044, (301) 596-0111.

September 16-19

**Applefest**, Minneapolis Auditorium and Convention Hall, Minneapolis, MN. Applefest is a conference convention and exposition featuring Apple computers and Apple-related products such as software, peripherals, accessories, and publications. The admission fee is \$5. Contact Northeast Expositions, 822 Boylston St., Chestnut Hill, MA 02167, (617) 739-2000.

September 19-24

**Data Processing Training Managers' Workshop**, Phoenix, AZ. This workshop is designed for people with less than 18 months' experience in coordinating data-processing training programs. Participants learn how to establish in-house education programs that will meet managements' objectives and ensure a high return on their organizations' investment in training. The fee is \$850. Full details are available from Linda Hubacek, Deltak Inc., 1220 Kensington Rd., Oak Brook, IL 60521, (312) 920-0700.

September 14-15

**The Future Factory**, New York, NY. For details, contact the Yankee Group, POB 43, Harvard Square, Cambridge, MA 02138, (617) 542-0100.

September 14-16

**Mini/Micro Computer Conference and Exposition**, Disneyland Hotel, Anaheim, CA. For complete details, contact Electronic Conventions Inc., Suite 410, 999 North Sepulveda Blvd., El Segundo, CA 90245, (213) 772-2965.

September 14-16

**Wescon/82 High-Technology Electronics Exhibition and Convention**, Anaheim Convention Center, Anaheim, CA. Among the topics to be covered are analog and digital signal processing, office automation, and semiconductor technology. For more details, contact Electronic Conventions Inc., Suite 410, 999 North Sepulveda Blvd., El Segundo, CA 90245, (213) 772-2965.

September 20-21

**Robot Research, Developments, and Applications in Canada**, Delta Inn, Mississauga (Toronto), Ontario, Canada. This conference is jointly sponsored by the Central Ontario Chapter of Robotics International of the Society of Manufacturing Engineers (RI-SME) and the National Research Council of Canada. Technical papers and presentations will address robot research and developments, applications, con-



trollers, programming languages, sensory feedback, education, and training. Full details are available from RI-SME Conference Secretariat, 6535 Mississauga Rd., Mississauga, Ontario, L5N 1A6, Canada.

September 20-23

**Logo**, Cambridge, MA. This workshop is part of Technical Education Research Centers' (TERC's) Microcomputers in Education series. The cost is \$300. For a brochure, contact TERC, 8 Eliot St., Cambridge, MA 02138, (617) 547-3890.

September 20-24

**Advanced FORTH Applications**, Belmont, CA. This course is designed for engineers, scientists, advanced technicians, and programmers associated with engineering groups. Among the topics to be addressed are engineering applications, floating point, communications, and sorting and searching. The fee is \$495. Contact Inner Access Corp., POB 888, Belmont, CA 94002, (415) 591-8295.

September 20-24

**Auditing in the Contemporary Computer Environment**, Oklahoma City, OK. This course is designed for internal auditors and financial and data-processing professionals. A comprehensive auditing approach for computer-based systems will be presented. Topics on the agenda include how to evaluate controls, how to prepare an audit report, and how to design a program of tests using questionnaires, checklists, software tools, and flowcharts. Contact Marge Umlor, EDP Auditors Foundation, 373 South Schmale Rd., Carol Stream, IL 60187.

September 20-24

**COMPCON Fall '82**, Capital Hilton Hotel, Washington, DC. This conference will

focus on the principles behind work-station technology, including local-area networks, operating systems, and new concepts in user interfaces. Topics of interest include reliability and availability techniques, network-wide databases, distributed architectures, network user environments, and standards. For information, contact COMPCON Fall '82, POB 639, Silver Spring, MD 20901, (301) 589-3386.

September 20-24

**Reliability Testing**, Academic Center, George Washington University, Washington, DC. Some of the topics to be covered in this short course include methodologies to improve the reliability of components, equipment, and systems; sequential tests for the exponential and binomial cases; and probability plotting techniques to find the parameters of the appropriate distributions to use. The course fee is \$785, which includes lecture notes. Contact Dr. Dimitri Keccioglu, Aerospace and Mechanical Engineering Dept., Building 16, Room 200B, University of Arizona, Tucson, AZ 85721, (602) 626-2495, or Stod Cordelyou, Continuing Engineering Education Program, George Washington University, Washington, DC 20052, (800) 424-9773; in the District of Columbia, (202) 676-6106.

September 21-22

**Word Processing/Information Systems Expo**, Sheraton Washington Hotel, Washington, DC. This conference and exposition will address the trends and advances in the word-processing industry. Among the topics to be covered are word processing and office integration, productivity measurement, and levels of managing an organization. Further details are available from National Trade

**Model EP-2A-87**

**EPROM Programmer**

The Model EP-2A-87 EPROM Programmer has an RS-232 compatible interface and includes a 2K, 4K or 8K buffer. Seventeen RS-232 commands allow another computer to download or remotely control the Programmer. INTEL, TEXTRONIX OR MOTOROLA formats are supported. The buffer may be edited directly from a CRT and EPROMS can be copied off-line. Power requirements are 115v 50/60 Hertz at 15 watts.

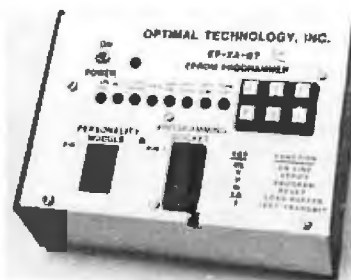

EP 2A-87-1	Programmer with 2K Buffer .....	\$575.00
EP 2A-87-2	Programmer with 4K Buffer .....	\$650.00
EP-2A 87-3	Programmer with 8K Buffer .....	\$725.00
	Non-Standard voltage (220v, 240v, or 100) .....	\$ 15.00

**Personality Modules**

PM-0	TMS 2708 .....	\$18.00	PM-5E	2816 .....	\$36.00
PM-1	2708 .....	18.00	PM-6	2704 .....	18.00
PM-2	2732 .....	34.00	PM-7	2758 .....	18.00
PM-2A	2732A .....	34.00	PM-8	MCM68764 .....	36.00
PM-3	TMS 2716 .....	26.00	PM-9	2764 .....	36.00
PM-4	2532 .....	34.00	PM-10	2564 .....	36.00
PM-5	2716 .....	18.00			
SA-64-2	2564 .....	39.00	SA-64-3	2764 .....	39.00

**Optimal Technology, Inc.**

Phone (804) 973-5482

Blue Wood 127

Earlsville, VA 22936



**LINE VOLTAGE TRANSIENT SUPPRESSORS**

Features Parallel Operation 5000 Hits/Second

**Clipstrip™ AND Clipper™**

**PROTECTS:**

- Computers
- Micro-Computer Systems
- Word Processors
- Cash Registers
- Power Supplies

**PROTECTS AGAINST:**

- High Energy Voltage Transients
- On-Off Switching
- Lightning Induced Transients
- Inrush of On/Off Power



DEALER INQUIRIES INVITED

Clipstrip 977E



LISTED

Clipper 678F



LISTED

WE HONOR

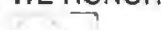

7133 Rutherford Rd.  
Baltimore, Md. 21207

800-638-9098  
(301) 298-3130

# Event Queue

Productions Inc., Suite 206, 9418 Annapolis Rd., Lanham, MD 20706, (301) 459-8383.

September 21-23

**Software/Expo-National**, Expocenter, Chicago, IL. This show is sponsored by *Infosystems* magazine. For complete details, contact Software/Expo, Suite 400, 222 West Adams St., Chicago, IL 60606, (312) 263-3131.

September 23-25

**The First International Conference and Exhibition on Medical Computer Science (Medcomp '82)**, Hilton Hotel and the University of Pennsylvania, Philadelphia, PA. This conference is sponsored by the IEEE (Institute of Electrical and Electronics Engineers) Computer Society's Technical Committee on Computational Medicine. It is a transdisciplinary forum for engineers,

medical professionals, and biomedical and computer scientists. Papers and exhibits will focus on topics such as the history and evolution of computers in medicine, artificial intelligence, software and systems evaluation, and signal and image processing. For additional information, contact the IEEE Computer Society, POB 639, Silver Spring, MD 20901, (301) 589-3386.

September 26-October 1

**Advanced Data Processing Training Management Workshop**, Sunnyvale Hilton Hotel, Santa Clara, CA. This seminar is intended for managers with a minimum of one year's experience, after completing the Data Processing Training Managers' Workshop (see September 19-24), or the equivalent in on-the-job experience. The fee is \$850.

Registration information is available from Linda Hubacek, Deltak Inc., 1220 Kensington Rd., Oak Brook, IL 60521, (312) 920-0700.

September 27-29

**Hands-on Pascal Workshop**, Washington, DC. For details, see September 13-15.

September 28-29

**The Future Factory**, Sunnyvale, CA. For details, contact the Yankee Group, POB 43, Harvard Square, Cambridge, MA 02138, (617) 542-0100.

September 28-October 1

**Applied Time Series Analysis**, Marina International Hotel, Marina del Rey, CA. Contact the Continuing Education Institute, Oliver's Carriage House, 5410 Leaf Treader Way, Columbia, MD 21044, (301) 596-0111.

September 28-October 1

**Computer Graphics**, San Diego, CA. This course is designed to provide a comprehensive overview of state-of-the-art computer-graphics software and hardware and to present an integrated approach to implementation of graphics applications. Topics to be addressed include technology fundamentals, software and hardware availability and selection criteria, and raster scan, vector, and color techniques. Participants receive a take-home graphics software package. The course fee is \$845. Information can be obtained from Ruth Dordick, Integrated Computer Systems, 3304 Pico Blvd., POB 5339, Santa Monica, CA 90405, (800) 421-8166; in California, call (213) 450-2060.

September 28-October 1

**Computer Trade Forum**, National Exhibition Centre, Birmingham, England. This trade show will bring together vendors, original equipment manufacturers, dealers, distri-

butors, retailers, service companies, and independent sales organizations. For complete details, contact Clapp & Poliak Inc., 245 Park Ave., New York, NY 10167, (212) 661-8410. In England, contact Clapp & Poliak Europe Ltd., 232 Acton Lane, London W4 5DL, 01-747-3131.

September 28-October 1

**Distributed Processing, Mini- and Microcomputer Implementations**, Washington, DC. This course will cover distributed processing concepts and techniques suitable for microprocessor applications. Other topics include design requirements of distributed systems, how to partition system tasks and hardware, and how to implement data links and protocols. The fee is \$845. Contact Ruth Dordick, Integrated Computer Systems, 3304 Pico Blvd., POB 5339, Santa Monica, CA 90405, (800) 421-8166; in California, call (213) 450-2060.

## October 1982

October 1-2

**The Third Annual Fall Conference on Classroom Applications of Computers**, San Jose, CA. This conference is sponsored by Computer-Using Educators, a nonprofit corporation. Topics will cover all areas of curricula from preschool through post-secondary school. Workshops, field trips, school visits, commercial exhibits, and a banquet dinner with a keynote speaker will be featured. Participation in all events is by preregistration only. Conference information is available by writing to Don McKell, Computer-Using Educators, POB 18547, San Jose, CA 95158.

October 1-7

**Electronics 82**, Bella Center, Copenhagen, Denmark. This

## COMPUTER GEAR—WHOLESALE!

Purchase Your Hardware And Software Directly From An OEM/System Integrator. Take Advantage Of Our Buying Power! We Stock Boards, Systems, Software, And Many Peripherals, For Almost Any Machine In Use Today. Call In Your Needs. **\$\$\$ Millions In Inventory—At Our Fingertips \$\$\$**

Some Examples Of Our In-Stock Deals: **\$\$\$ MONTH SPECIALS \$\$\$**

CP/M SOFTWARE	HARDWARE	HARDWARE	HARDWARE
WORDSTAR \$\$\$\$\$ 259	*MONITORS*	MX70 399	*GOOBOOT*
MAILMERGE 99	"AMDEK"	MX80 479	2-80CPU 219
SPELLSTAR 159	100W \$\$\$\$ 89	MX80/FT 569	8085/88 319
DASTAR 209	300G \$\$\$\$ 159	MX100 745	8086/87 CALL
CALCSTAR 199	COL I 349	OKI 400 \$ 200	DISK I 359
MIBASIC 80 \$\$\$\$\$ 199	COL II \$\$\$\$ 725	OKI 402A \$ 400	DISK 2 \$\$\$\$\$ 599
MB-80 COMP 275	"SANYO"	OKI 403A \$ 710	RAM 16 \$\$\$\$\$ 499
FORTRAN 80 349	9"GR \$\$\$\$ 159	OKI 404P \$ 1040	RAM 17 \$\$\$\$\$ 429
COBOL 80 575	12" BW \$\$\$\$ 199	OKI 404S \$ 1140	RAM 20 299
MARCO 80 169	12" GN \$ 209	MS-DOS HARDWARE	RAM 21 1325
QUICKSCREEN 129	13" COM \$ 389	SOFTWARE	INTFACER 1 189
SUPERVIZ 79	13" RGB \$ 799	RAMCARD 149	INTFACER 2 189
GBT CP/M80 149	*NEC*	SIEMENS 375	INTFA 3-5 445
GBT CP/M86 269	12 GR 175	GETSUB 2569	INTFA J-8 525
QBASIC II \$\$\$\$\$ 459	12" COM 369	MP/M8-16 769	INTFA 4 \$\$\$\$\$ 269
FMS 80 675	12 RGB 995	WARD DISKS CALL	ENCL DESK 669
DEMO 125	*PRINTERS*		*MORROW*
CONDOR I 229	8023A 509		DECISION 1 1399
CONDOR II 439			DJB' SUBSYS 895
CONDOR III 709			DJDMAW/CP/M 438
ACCT'G PLUS 439			DJZDW/CP/M 349
DEMO 225			MULTI I/O 299
TYMAKER II 249			SWITCHBOARD 219
SUPERCALC 225			12 SLOT MOM 139
SPELLBINDER 289			*SSM BOARDS*
SPELLGUARD 219			MB64K RAM 729
SPRAW 99			MB10A 16K 259
UCRAFT LEGBILL 545			YAMA 80-24 \$ 199
DEMO 65			
MICRONIX 475			
WIPAS & C 949			
PAS & C 849			
C-COMPIER 675			
APPLE & OTHER FORMATS			
-CALL			

### WOW!

55 SPECIALS IS GOOD THROUGH MONTH END. As supplies last! Some checks may be given if possible. Cash Sales Only!

TERMS OF SALE: CDD-CASH OR CREDITIFIED. GIVE YOUR VISA/MC NUMBER FOR OUR RECORDS FOR UPS REFUSAL RETURN. ANY PREPAID ORDERS SAVE. COD. CP/M-TM DIGITAL RESEARCH.

## CUSTOM COMPUTER TECHNOLOGY

1 CRAFTSMAN COURT—BOX 4160  
SEDONA, ARIZONA, 86340  
(602) 282-6299

PRICES & AVAILABILITY SUBJECT TO CHANGE. ALL PRODUCTS NEW, AND CARRY FULL MANUFACTURER'S WARRANTIES. CALL FOR CATALOG. FREE TECHNICAL HELP TO ANYONE WE CAN CONFIGURE BOARDS & SOFTWARE FOR YOUR SYSTEM, PLUG-IN & GO. AZ RESIDENTS ADD APPLICABLE SALES TAX.

will be the largest electronics fair in Scandinavia this year. It will feature demonstrations, conferences, talks, seminars, and commercial exhibits ranging from automation equipment to technical magazines. Approximately 250 exhibitors, representing almost 1000 firms, are expected. For particulars, contact Bella Center A/S, Center Blvd., DK-2300 Copenhagen S, Denmark; Tel: (01) 51 88 11; Telex: 31188 bella dk.

October 3-8

**Data Processing Training Managers' Workshop**, Loews Westbury Hotel, Toronto, Ontario, Canada. For details, see September 19-24.

October 4

**Knowledge Engineering in the 1980s**, Boston, MA. For details, see September 13.

October 4-8

**Auditing in the Contemporary Computer Environment**, Hartford, CT. For details, see September 20-24.

October 5-7

**The Third Annual Southwest Semiconductor Exposition**, Civic Plaza Convention Center, Phoenix, AZ. "Automation/Automania?" is the theme for this year's technical conference. Suppliers of equipment and materials dedicated to the semiconductor, printed-circuit board, and hybrid industries will attend. Among the issues to be explored are the latest trends in general wafer processing and printed-circuit board manufacturing, hybrids, automation, robotics, and automatic testing. Highlighting this conference will be a preventive maintenance training forum. Contact Cartledge & Associates Inc., Suite 1014, 491 Macara Ave., Sunnyvale, CA 94086, (408) 245-6870.

October 7-8

**Workshop on Automotive Applications of Microprocessors**, Hyatt Regency Hotel, Dearborn, MI. This workshop is a forum on applications of microprocessors to automobiles, trucks, vans, allied automotive products, plants, and processors. Topics of interest include engine control, engine and vehicle diagnostics, instrumentation and display, safety systems, drive-train control, plant process and quality control, and test equipment. For further details, contact S. Murtuza, Department of Electrical Engineering, University of Michigan, 4901 Evergreen Rd., Dearborn, MI 48128, (313) 593-5028 or (313) 593-5420.

October 8-11

**Electronica**, Hynes Auditorium, Boston, MA. This show will feature a wide variety of personal electronics equipment, including computers, electronic games, ham radios, and projection TV. For more information, contact Northeast Expositions, 824 Boylston St., Chestnut Hill, MA 02167, (617) 739-2000.

October 10-14

**Association of Records Managers and Administrators (ARMA) Annual Conference and Exposition**, Atlanta, GA. This is ARMA's twenty-seventh annual meeting. Word processing, data communication, and other aspects of information storage and retrieval will be examined. Additional information can be obtained from National Trade Productions Inc., 9418 Annapolis Rd., Lanham, MD 20706, (301) 459-8383.

October 10-14

**Issue '82**, Monteleone Hotel, New Orleans, LA. This is the sixth annual conference of Issue, an independent non-

## MICROSTAT® - Release 3.0

### MICROSTAT® + baZic® = PERFORMANCE

The best just got better! MICROSTAT has been the leader in the statistics field for microcomputers since 1979, and the new release 3.0 outperforms and is noticeably faster than previous versions. Just a few of the features include:

#### GREATER ACCURACY

BCD with up to 14 digit precision;

#### PROGRAM ENHANCEMENTS

Missing data capabilities and many more;

#### FASTER EXECUTION

Calculation time greatly reduced;

#### DYNAMIC FILE ALLOCATION

Data can be inserted, added, or deleted;

#### SPECIAL PRICE:

For a limited time get MICROSTAT plus baZic complete with program disk and documentation for each for \$395.00, save \$50.00!

The MICROSTAT - baZic version requires: a Z80 CPU, CP/M™ and 48K of memory. Available formats: 8" SD disk or 5¼" North Star only. Check with your dealer for other formats. Also available for: Microsoft's Basic-80™, North Star DOS and IBM. For more information, call or write:

#### ECOSOFT INC.

P.O. Box 68602  
Indianapolis, IN 46268-0602  
(317) 255-6476



MICROSTAT is a registered trademark of ECOSOFT, INC.  
baZic is a registered trademark of MICROMIKES, INC.  
CP/M is a registered trademark of DIGITAL RESEARCH  
Basic-80 is a registered trademark of MICROSOFT

**Edix™ + Wordix™ has word processing features that our competitors are still dreaming about . . .**



**\$390 buys the whole dream.**

#### Edix Editing Features

Up to 4 screen windows  
Up to 12 file buffers  
Top-to-bottom and side-to-side scrolling.  
Regular expression searching and translating  
Intra- and inter-buffer moving and copying  
Online help  
Online tutorial

Call or write for our brochure.

#### Wordix Formatting Features

Auto footnotes  
Auto table of contents  
Auto hyphenation  
Multi-line headers and footers  
Multi-column layout  
Powerful macros  
Data file access

Requires 128K IBM PC.  
Edix alone: \$195

**EMERGING**  
TECHNOLOGY

Box 154 Louisville, Colorado 80027 303-447-9495

™ Trademark of Emerging Technology Consultants, Inc.

# DEC DISK CARTRIDGES Overnight!

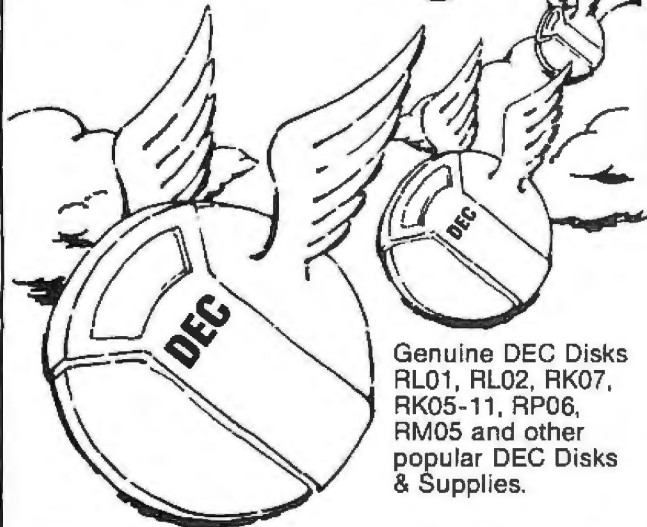

Genuine DEC Disks  
RL01, RL02, RK07,  
RK05-11, RP06,  
RM05 and other  
popular DEC Disks  
& Supplies.

## RADGO SALES CO.

3988 McMann Rd., Cincinnati, Ohio 45245

**TOLL FREE Ordering 1-800-543-1986**  
except in Ohio phone 1-513-752-6880

Ask for free catalog

## ADVANCED GRAPHICS SOFTWARE NOW—FOR MICROCOMPUTERS!

512 x 240  
RESOLUTION

FOR COMPUSTAR®  
SUPERBRAIN®  
TRS-80® MODEL II

USE WITH  
HARDWARE RETROFIT  
FROM \$595<sup>00</sup>

### XCEL™ GRAPHICS SOFTWARE

- Symbol Generator \$175.00
  - Graph Plotter \$175.00
  - 3D Generator \$345.00
  - Surface Plotter \$395.00
  - Graphics Terminal Emulator \$395.00
  - Screen Printer \$65.00
- ANADEX  
EPSON  
IDS



(213) 320-6604

**MAXTEK, INC.** 2908 Oregon Court, Torrance, CA 90503

Available in Europe from Micronex Ltd., Chew Magna, England 3042 (STD 027-589 3042)

TRK: 80 registers, 10 channels, 1000 samples, 1000 lines, 1000 dots, 1000 lines, 1000 dots, 1000 lines, 1000 dots

## Event Queue

profit organization of SPSS Inc. software users and coordinators. Papers will address such topics as data analysis, research training, computer graphics, and training materials and documentation. Contact the Executive Coordinator of Issue Inc., POB 11385, Chicago, IL 60611, (312) 329-2400.

October 10-15

**Data Processing Training Managers' Workshop**, Oak Brook Marriott Hotel, Oak Brook, IL. For details, see September 19-24.

October 11-12

**Personal Computer Peripherals Market Analysis**, the Anatole, Dallas, TX. The fee for this seminar is \$495. Further details are available from Future Computing Inc., 900 Canyon Creek Square, Richardson, TX 75080, (214) 783-9375.

October 11-14

**Info 82**, Coliseum, New York, NY. More than 70 software companies and 45 hardware manufacturers are expected to display information-management-related equipment and software. Highlighting this event will be a Software Center featuring demonstrations and a consultation desk for visitors. Complete show details are available from Clapp & Poliak Inc., 708 Third Ave., New York, NY 10017, (800) 223-1956; in New York, (212) 661-8410.

October 12-13

**The Future: Home**, New York, NY. For details, contact the Yankee Group, POB 43, Harvard Square, Cambridge, MA 02138, (617) 542-0100.

October 12-15

**Distributed Processing, Mini- and Microcomputer Implementations**, New York, NY.

For details, see September 28-October 1.

October 13-15

**Advanced Electronic Data Processing Auditing Concepts**, Los Angeles, CA. For details, see September 13-15.

October 14-15

**Man Machine Interface**, Columbia Inn, Columbia, MD. For information, contact the Continuing Education Institute, Oliver's Carriage House, 5410 Leaf Treader Way, Columbia, MD 21044, (301) 596-0111.

October 15-17

**The Second Annual Symposium on Small Computers in the Arts**, Philadelphia, PA. Papers, tutorials, workshops, a gallery display of computer-generated prints and plots, films and video tapes, and computer-generated music performances are parts of this event. Topics of interest include computer graphics and animation, computer-automated sculpture, choreography, designs, and computer-generated music. The Annual Philadelphia Computer Music Concert is the featured attraction of this symposium. Address inquiries to the Symposium on Small Computers in the Arts, POB 1954, Philadelphia, PA 19105.

October 15-19

**Vidcom '82: International Telematics and Data Banks Market**, Palais des Festivals, Cannes, France. The eighth annual Vidcom is expected to attract more than 7000 video-communications and telematics professionals. Exhibitors from more than 60 countries will show products designed for the publication, transmission, reception, and creation of telematics services, including terminals, composition equipment, and communications software. Conference sessions will explore



## Event Queue

October 21-24

**EdCOM '82—The National Computer Conference and Expo for Educators**, Los Angeles Convention Center, Los Angeles, CA. More than 200 seminars, workshops, demonstrations, and exhibits are planned. In-depth tutorials and hands-on sessions will be held. Topics of interest include computer-aided instruction, administrative uses of microcomputers, classroom management, programming, research applications, computer literacy, and authoring languages. Information is available from Jayne LaFountain, EdCOM '82, 2629 North Scottsdale Rd., Scottsdale, AZ 85257.

October 24-26

**Texas Association for Educational Data Systems (TAEDS) Eighteenth Annual Convention**, Villa Capri Hotel,

Austin, TX. The conference theme is "Computer Literacy for Education, Industry, and the Community." Contact Dr. Terry Bishop, Austin ISD, 6100 Guadalupe St., Austin, TX 78752.

October 24-29

**Data Processing Training Managers' Workshop**, Hyatt Regency Hotel, Tampa, FL. For details, see September 19-24.

October 25-27

**Advanced Electronic Data Processing Auditing Concepts**, Tulsa, OK. See September 13-15 for details.

October 25-27

**The 1982 ACM (Association for Computing Machinery) Annual Conference**, ACM '82, Dallas Hilton Hotel, Dallas, TX. Among the topics to be addressed are program-

ming languages, artificial intelligence, office automation, networks, graphics, computers and the handicapped, and operating, database, and distributed systems. General conference information is available from William Burns, ACM '82 Chairman, E-Systems Inc., POB 226118, Dallas, TX 75266, (214) 272-0515, ext. 3916.

October 26-28

**The First IEEE Computer Society International Symposium on Medical Imaging and Image Interpretation, ISMII '82**, International Congress Center, Berlin, West Germany. This symposium is sponsored by the IEEE (Institute of Electrical and Electronics Engineers) Computer Society's Technical Committee on Computational Medicine. It will provide a transdisciplinary forum for biomed-

ical and computer scientists, engineers, medical physicists, and physicians from universities, medical centers, industry, and government. Papers and panel discussions will examine a variety of topics, including microscope imaging, medical computer graphics, medical device regulation, computer-aided diagnosis, and image analysis systems. Equipment will be displayed. A thorough description of ISMII '82 is available from the IEEE Computer Society, POB 639, Silver Spring, MD 20901, (301) 589-3386.

October 26-29

**Computer Graphics**, Boston, MA. For details, see September 28-October 1.

October 26-29

**Distributed Processing, Mini- and Microcomputer Imple-**

## DIGITAL DATA RECORDERS



\$323.30

### FEATURES:

- 4800 BAUD data rate (3" per second) • 1 ERROR in 10<sup>9</sup> BITS
- RS-232 or TTL Interface—NO EXTERNAL INTERFACE REQUIRED
- ASYNCHRONOUS COMMUNICATIONS—STANDARD "HANDSHAKING"
- SPEED STABILITY—LONG TERM  $\pm .1\%$  • COMPATIBLE with DC-3
- Works with CERTIFIED DATA or high quality V F<sub>60</sub> AUDIO TAPES
- OPTIONS: 115v ac, 220v ac, 12v dc; Stand alone; Rack-mountable; 9600 BAUD.

The PD-1 SERIES DIGITAL DATA RECORDER continues to set new NRZ INDUSTRY STANDARDS. Its tachometer feedback LC stabilized motor circuit and heavy duty drive mechanism provide STABILITY, ACCURACY and RELIABILITY. You get LESS BIT DROP-OUT when capturing crucial information at HIGHER DATA TRANSFER RATES...at a MUCH LOWER COST.\*

### USED IN:

- PROCESS CONTROL
- POINT-OF-SALE
- TELEPHONE SWITCH LOGGING (Call Activity and Station Message Detail)
- DIAGNOSTIC SUPPORT (local/remote)
- HARD DISC BACKUP (for personal or small computer systems)
- Many Other Applications

\* An intelligent, buffered version of this device is also available.

TO ORDER, DIAL:  
(201) 356-9200



**PEGASUS DATA SYSTEMS**  
236 Lackland Drive  
Middlesex, N. J. 08846

## Model 953A EPROM PROGRAMMER

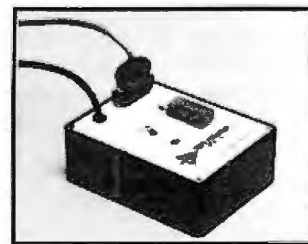

- Programs 2508, 2758, 2516, 2716, 2532 and 2732 five volt EPROMS.
- Complete - no personality modules to buy.
- Intelligent - microprocessor based, programs and verifies any or all bytes.
- RS-232 serial interface - use with computer or terminal.
- Verify erasure command - verifies that EPROM is erased.
- Extended diagnostics - error output distinguishes between a bad EPROM and one which needs erasing.
- May be used for extremely reliable data or program storage.
- All power on programming socket under processor control, LED warning light indicates when power is applied.
- Complete with Textool zero insertion force socket.
- High performance/cost ratio.
- Standard DB-25 I/O connector.

PRICE \$289



**BAY TECHNICAL ASSOCIATES, inc.**

HWY. 603, P.O. BOX 387  
BAY ST LOUIS, MISSISSIPPI 39520  
(601) 467-8231

mentations, San Diego, CA. For details, see September 28-October 1.

October 26-31

**The Fourth International Office Trade Fair, Orgatechnik '82, Cologne, West Germany.** More than 1300 companies from 25 countries will exhibit the complete spectrum of office and information system products. Among the concurrent events planned are the KTV - Congress for Text Processing, Dafta '82 - Data Protection Conference, and Telecom '82 Germany - Congress for Telecommunications in Business and Industry. For further information, contact Messe- und Ausstellungs-Ges.m.b.H Köln, POB 21 07 60, D-5000 Cologne 21, West Germany; Telex: 8 873 426 a mua d.

October 27-29

**Program/Project Management: Manufacturing Industries, Hyatt Regency, Austin, TX.** For details, see October 18-20.

October 28-31

**Mid-Atlantic Computer Show and Office Equipment Exposition, Armory/Starplex, Washington, DC.** This show is produced by Computer Expositions Inc., POB 3315, Annapolis, MD 21403 (800)

368-2066; in Maryland, (301) 263-8044.

October 28-31

**Applefest, Civic Center, Houston, TX.** See September 16-19 for details.

October 30-November 2

**The Sixth Annual Symposium on Computer Applications in Medical Care (SCAMC), Sheraton Washington Hotel, Washington, DC.** Topics to be addressed include medical informatics, health-care administration, information systems in health care, and artificial intelligence in medicine. Panel discussions, workshops, applications and methods demonstrations, and commercial exhibits are on the agenda. Highlighting this show will be the final round of the student paper competition. Information is available from Bruce I. Blum, SCAMC-Office of Continuing Education, George Washington University Medical Center, 2300 K St. NW, Washington, DC 20037, (202) 676-4285.

## November 1982

November 1-3

**Hands-on Pascal Workshop, New York, NY.** See September 13-15 for complete details.

November 1-5

**Digital Modal Analysis, Columbia Inn, Columbia, MD.** Particulars are available from the Continuing Education Institute, Oliver's Carriage House, 5410 Leaf Treader Way, Columbia, MD 21044, (301) 596-0111.

November 5-7

**Electronica, Arlington Park, Chicago, IL.** See October 8-11 for particulars.

November 7-9

**The Seventeenth Annual Conference of the New York State Association of Educational Data Systems (NYSAEDS), Americana Hotel, Albany, NY.** The theme for this conference is "Moving Ahead with Instructional Computing." This conference will address the administrative uses of microcomputers and curricular issues such as computer modifications for the disabled. Hardware analyses and presentations on Logo and Pascal are planned. The conference fee is \$200, which includes registration, two nights' lodging, banquets, and a luncheon. For more information, contact Gary Bruce, Program Chairperson, 55 School St., Delevan, NY 14042.

November 7-12

**Advanced Data Processing Training Management Workshop, Marriott Inn North, Dallas, TX.** For details, see September 26-October 1.

November 8-10

**COMDEX/Europe, RAI Exhibition Center, Amsterdam, Holland.** This show is expected to attract more than 500 exhibitors of systems, peripherals, software, media, supplies, and services. Details are available from the Interface Group, 160 Speen St., POB 927, Framingham, MA 01701, (800) 225-4620; in Massachusetts, (617) 879-4502.

November 8-10

**Hands-on Pascal Workshop, Boston, MA.** For details, see September 13-15.

November 8-12

**Personal Microcomputer Interfacing and Scientific Instrumentation Automation, Virginia Polytechnic Institute and State University, Blacksburg, VA.** This is a hands-on workshop where the participant designs and tests concepts with the actual hardware. The fee is \$595. Contact Dr. Linda Leffel, C.E.C., Virginia Polytechnic Institute and State University, Blacksburg, VA 24061, (703) 961-4848.

## \$\$\$ READ THIS IF YOU WANT TO SAVE MONEY \$\$\$ ALL HARDWARE AND SOFTWARE FROM 10%-35% OFF!

**APPLE BUSINESS SOFTWARE**  
Visicalc \$189  
Versaform \$299  
Supercalc \$210  
DB Master \$185  
DB Master Util. Pak 1 & 2 \$ 79  
Format II \$275  
Pro Easywriter Combo }  
Accounting Plus II } Call  
INVOICE PLUS } for  
FMS-80, 81, 82 } Best  
dBASE II } Prices  
VISICORP Software }  
★ THE LAST ONE ★  
The program that writes  
programs! WE HAVE IT!  
Last One Manual }  
\$ 25  
**APPLE PERIPHERALS**  
Thunderclock \$125  
Mountain Computer Prod. }  
Videx Products } for  
Microsoft Products } Best  
Corvus Products } Prices

★ **INTRO SPECIAL** ★  
BASIS 108 Computer  
w/choice of drives } Call  
Any 4 APPLE Games } \$100  
80 Col. Visicalc PreBoot } Call  
★ **NEW PRODUCT LINES** ★  
IBM Software and  
Peripherals }  
Atari Software } Call  
TRS-80 Software } for  
NEC PC8001A } Best  
ALTOS Computers } Prices  
ATARI 400 & 800 }  
★ **SPECIAL** ★ **MICROSOFT**  
**PREMIUM SYSTEM, incl**  
Microsoft Z-80 Card }  
Microsoft 16K Card } All  
Videx 80 Column Card } for  
Videx Soft-Switch } Only  
CP/M User's Guide } \$625  
★ **DISKETTE SPECIALS** ★  
Maxell MD-1 (Box of 10) \$ 32  
Maxell 8" (Box of 10) \$ 41

**COMMUNICATIONS**  
Hayes Micromodem II \$275  
Hayes Smart Modem \$235  
Hayes Chronograph \$225  
Novation Apple Cat II \$335  
Micro Courier \$210  
Pro Z-Term Call  
**PRINTERS & INTERFACES**  
NEC Spinwriter 7700/3500 Call  
Okidata Microline 83A \$745



Minimum order \$100. Cashiers checks and money orders accepted. Add 3% for VISA or MC. Add 2% for shipping/insurance/handling. GPS. No COD. Prices subject to change. Call to verify. Order hours 9-6 PDT, Mon-Fri. Personal checks allow 30 days to clear. All products with full manufacturer's warranty, factory sealed. Call, residents add 6% sales tax.  
Apple is a registered trademark of Apple Computer Inc. All brand names are registered trademarks.

Anadex Products  
CCS Interface Cards }  
Qume and Diablo } Call  
EPSON w/Grafltrax Plus } for  
Micro Buffer II } Best  
Grappler } Prices  
**MICRO PRO**  
Wordstar \$230  
Supersort \$130  
Mail Merger \$ 99  
Data Star \$230  
Spell Star \$130  
Calc Star \$130  
CP/M 8" Versions Call

**COMPUTER SYSTEMS**  
Xerox 820 Computer Call  
Xerox Peripherals Call  
**MONITORS**  
NEC Hi-Res 12" Green \$129  
NEC RGB 12" Color \$995  
Sanyo Monitors Call  
Amdek Monitors Call  
**MISCELLANEOUS**  
Micro Sci Drives Call  
16-Bit Apple Card Call  
TG Joysticks/Paddies Call  
ABT Keypads \$ 99  
System Saver Fan \$ 77



1400 GRANT AVE. / NOVATO, CALIFORNIA 94947  
IMMEDIATE DELIVERY  
PHONE ORDERS CALL COLLECT  
415-892-7139 or 415-897-1414

## Event Queue

November 9-11

**The Government-Industry Data Exchange Program-GIDEP**, McCormick Inn, Chicago, IL. This annual workshop is open to anyone interested in the exchange of technical information relating to engineering, failure experience, reliability and maintainability, and metrology. For more information, contact the Officer-in-Charge, GIDEP Operations Center, Corona, CA 91720.

November 9-12

**Computer Graphics**, New York, NY. For details, see September 28-October 1.

November 9-12

**Distributed Processing, Mini- and Microcomputer Implementations**, Boston, MA. See September 28-October 1 for information.

November 14-19

**Data Processing Training Managers' Workshop**, Westin Bay Shore Inn, Vancouver, British Columbia, Canada. For details, see September 19-24.

November 15

**Knowledge Engineering in the 1980s**, San Francisco, CA. See September 13 for further information.

November 15-17

**Microcomputer Interfacing, Design and Programming Using the Z80/8085/8080**, Virginia Polytechnic Institute and State University, Blacksburg, VA. This is a hands-on workshop with the participant designing and testing concepts with the actual hardware. The fee is \$395. Contact Dr. Linda Leffel, C.E.C, Virginia Polytechnic Institute and State University, Blacksburg, VA 24061, (703) 961-4848.

November 15-19

**The IX Latin American Congress on Banking Automation**, ATLAPA Convention Center, Panama City, Republic of Panama. This conference is sponsored by the Latin American Federation of Banks, the Latin American Center for Banking Automation, and the Panama Banking Association. Seminars, conferences, and lectures will be complemented by exhibits of automatic data-processing and telecommunications equipment related to banking operations. For details, contact Asociación Bancaria de Panamá, Apartado 4554—Panamá 5, Republic de Panamá; Tel: 25-1863.

November 16-19

**Computer Graphics**, San Francisco, CA. For details, see September 28-October 1.

November 18-21

**Applefest**, Brooks Hall, San Francisco, CA. See September 16-19 for details.

November 18-19

**The Sixth Western Educational Computing Conference**, Kona Kai Club, San Diego, CA. This conference is presented by the California Educational Computing Consortium. It's intended for instructors and administrative personnel at the college and university level. The theme is "Bringing the Information Age to the Campus." Papers will address such topics as student involvement in database design, administrative computing in continuing education, the educational software dilemma, and learning economics with a microcomputer. Contact Professor Frances Grant, Center for In-

formation and Communications Studies, California State University, Chico, CA 95929.

November 30-December 2

**The 1982 Autofact 4 Conference and Exposition**, Civic Center, Philadelphia, PA. This show is sponsored by the Computer and Automated Systems Association of the Society of Manufacturing Engineers (CASA/SME). The focus will be on computer-aided design and manufacturing (CAD/CAM) and the expanding technologies of computer-integrated manufacturing (CIM) and the automated factory. Tutorials and sessions will address analysis and simulation, robotics, assembly, quality assurance, scheduling, material handling, and other related topics. Additional information is available from CASA/SME Public Relations, One SME Dr., POB 930, Dearborn, MI 48128, (313) 271-0777. ■

In order to gain optimal coverage of your organization's computer conferences, seminars, workshops, courses, etc notice should reach our office at least three months in advance of the date of the event. Entries should be sent to: Event Queue, BYTE Publications, POB 372, Hancock NH 03449. Each month we publish the current contents of the queue for the month of the cover date and the two following calendar months. Thus a given event may appear as many as three times in this section if it is sent to us far enough in advance.

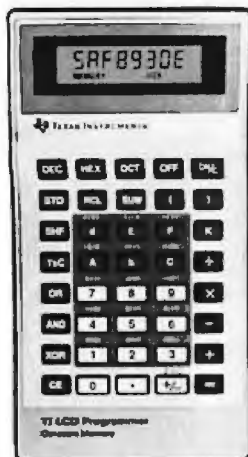

TEXAS INSTRUMENTS  
INCORPORATED

## New! TI LCD Programmer.

### Hexadecimal and Octal Calculator/Converter.

The brand new tilt-top TI LCD Programmer can save you hours of work. It was designed specifically for the problems you do, and has features that make it ideally suited for applications in computer programming, debugging, repair and digital logic design.

- Performs arithmetic in any of three number bases — OCT, DEC, HEX.
- Integer, two's complement arithmetic in OCT and HEX.
- One's complement capability in OCT and HEX.
- Converts numbers between OCT, DEC and HEX.
- Fifteen sets of parentheses available at each of four processing levels.
- Logical functions AND, OR, EXCLUSIVE OR and SHIFT operate bit by bit on OCT or HEX numbers.

Unisource Electronics has committed to buy TI's initial production of this unique product. Availability is limited! Order now.

### 15-Day Free Trial.

The best way to evaluate the TI LCD Programmer is to try it yourself — on the job — for 15 days. If you're not 100% satisfied, simply return it for a full refund. Order now by calling toll-free:

**1-800-858-4580**

In Texas call 1-808-745-8835

Lines open 8 am to 6 pm CST



Just give us your name, shipping address and Visa or MasterCard number and we will charge the tax deductible\* \$75.00 purchase price, plus \$2.00 shipping and handling (Texas residents also add 5% sales tax) to your account. Or send your check or money order to:

**Unisource Electronics, Inc.**  
P.O. Box 64240 • Lubbock, Tx. 79464

\* When used for business.



# A Weaving Simulator

---

Paul W Heiser  
 225 Long Meadow Circle  
 Pittsford, NY 14534

---

Before setting up a loom, a weaver wants to know what the resulting pattern will look like in the finished material. Using pencil and graph paper, he usually lays out a set of three configurations representing the tie-up, the threading, and the treadling of the loom. (An example of these input configurations, together with the resulting pattern, is illustrated in figure 1.) By marking these inputs

with Xs and Os or some other combination of symbols, the weaver defines whether certain threads will lie above or below other threads. Then, by moving from points in the treadling to points in the tie-up to points in the threading, he can determine the final pattern in the woven material.

This process is a tedious one that can require anywhere

```

X O O X   X O O O X O O O O X O O O X O O O X X O X X O O O O O O O O O X X O X X O O O
O O X X   O X O O O X O O O X O O O X O O O X O O X O O X O O O O O O O O O X O O X O O X O O
O X X O   O O X O O O X O X O O O X O O O X O O O O O O X O O X O O O O O O O O O O O O X O
X X O O   O O O X O O O X O O O X O O O X O O O O O O O O O O O X X O X X O O O O O O O O O X
  
```

```

O O X O
O X O O
X O O O
O O O X
O O X O
O X O O
X O O O
O O O X
O O X O
O X O O
X O O O
O O O X
O O X O
O X O O
O O O X
X O O O
O X O O
O O X O
O O O X
O O O X
O O X O
O X O O
O X O O
O O X O
O O O X
O O O X
O O X O
O X O O
O X O O
O O X O
O O O X
O O O X
O O X O
O X O O
O X O O
O O X O
O O O X
O O O X
O O X O
  
```

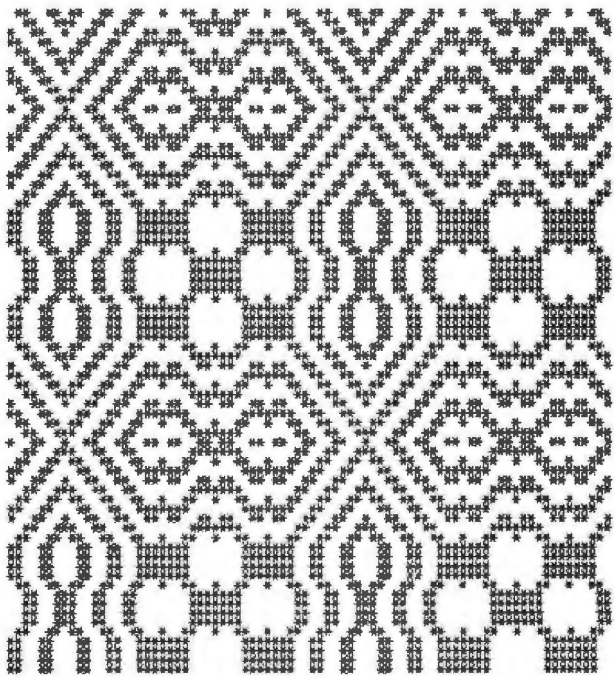

**Figure 1:** Sample output of a coarse-thread pattern produced by the WEAVE program using a Diablo 1650 printer. The loom-setup matrices described in the text are shown as groups of Xs and Os. The threading matrix (E-matrix) runs across the top of the figure; the tie-up matrix (A-matrix) is the four-by-four group at the upper left. The treadling matrix (B-matrix) is the vertical group to the left, directly below the tie-up matrix. The resulting pattern is printed using asterisks (the weave pattern shown is on a different scale from the configuration matrices).

## WARNING!

**Electric Power Pollution.  
Spikes & Lightning  
HAZARDOUS to  
MICROCOMPUTERS!!**

Patented ISOLATORS provide protection from ...

- Computer errors cause by power line interference
- Computer errors due to system equipment interaction
- Spike damage caused by copier/elevator/air conditioners
- Lightning caused damage

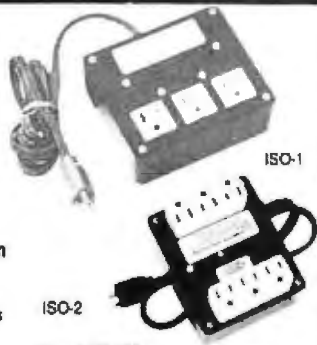

Pat. #4,259,705

### MONEY BACK GUARANTEE!

- ISOLATOR (ISO-1) 3 isolated 3-prong sockets; Spike Suppression; useful for small offices, laboratories, classrooms. .... \$89.95
  - ISOLATOR (ISO-2) 2 isolated 3-prong socket banks; (6 sockets total); Spike Suppression; useful for multiple equipment installations. .... \$69.95
  - SUPER ISOLATOR (ISO-3) similar to ISO-1 except double isolation & oversize Spike Suppression; widely used for severe electrical noise situations such as factories or large offices. .... \$104.95
  - SUPER ISOLATOR (ISO-11) similar to ISO-2 except double isolated socket banks & Oversize Spike Suppression; for the larger system in severe situations. .... \$104.85
  - MAGNUM ISOLATOR (ISO-17) 4 Quad isolated Sockets; Multiple Spike Suppressors; For ULTRA-SENSITIVE Systems in extremely harsh environments. .... \$181.95
  - CIRCUIT BREAKER, any model (Add-CB) .... Add \$9.00
  - REMOTE SWITCH, any model (Add-RS) .... Add \$16.00
- AT YOUR DEALERS MasterCard, Visa, American Express  
ORDER TOLL FREE 1-800-225-4878 (except AK, HI, PR & Canada)

**Electronic Specialists, Inc.**

171 South Main Street, Box 389, Northwick, Mass 01760  
(617) 655-1532

## a message to our subscribers

From time to time we make the BYTE subscriber list available to other companies who wish to send our subscribers promotional material about their products. We take great care to screen these companies, choosing only those who are reputable, and whose products, services or information we feel would be of interest to you. Direct mail is an efficient medium for presenting the latest personal computer goods and services to our subscribers.

Many BYTE subscribers appreciate this controlled use of our mailing list, and look forward to finding information of interest to them in the mail. Used are our subscribers' names and addresses only (no other information we may have is ever given).

While we believe the distribution of this information is of benefit to our subscribers, we firmly respect the wishes of any subscriber who does not want to receive such promotional literature. Should you wish to restrict the use of your name, simply send your request to the following address.

BYTE Publications Inc  
Attn: Circulation Department  
70 Main St  
Peterborough NH  
03458

from 20 minutes to an hour, depending on the size and complexity of the input configurations and how many mistakes the weaver makes. If he is not pleased with the resulting pattern, he may alter one or more of the inputs and repeat the process until he develops a satisfactory result.

A weaver may not realize it, but as he lays out his pattern on paper, he is actually defining and multiplying matrices. The fact that these matrices are composed of elements having ones or zeros as their values gave me the idea of writing a program to simulate the operation of a loom. The program, called WEAVE, allows use of the keyboard to define the elements of the input matrices. The computer then does all the work of multiplying the matrices to describe and display the resulting pattern.

All the data entry for WEAVE can be done in less than one minute. This is made possible by extensive use of INCHAR\$ statements, which do not require the typing of Return, and by requiring definition of only the "up" threads. For a complex pattern involving very large matrices, the calculations can take several minutes, and the printout can take five or ten minutes. During all this time the user is free to do other things. The pattern that is finally printed out is far more accurate and intricate than one that could be drawn by hand in any reasonable length of time.

When I wrote the original version of WEAVE almost two years ago, I owned a printer with only normal typewriter resolution, which was too coarse to produce satisfactory patterns. Recently, however, I purchased a Diablo 1650 I/O (input/output) terminal, and its high-

*Text continued on page 518*

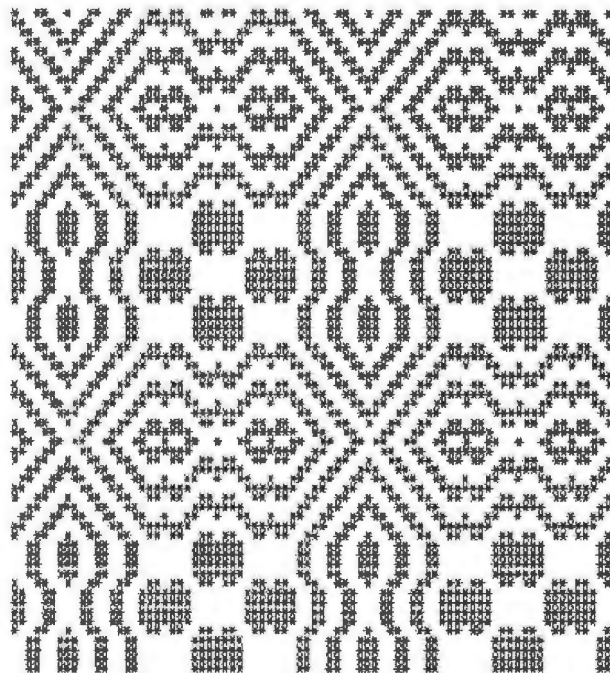

Figure 2: This pattern is the back side (negative) of the pattern shown in figure 1.

**Listing 1:** North Star BASIC program WEAVE, which will produce a woven pattern when provided with the tie-up, threading, and treadling configuration of a loom. Extensive use is made of the INCHAR\$ function, which permits single-character input without the need to type a carriage return.

```

10 REM                      WEAVE
20 REM
30 REM  WRITTEN BY PAUL HEISER, PITTSFORD, NY.
40 REM
50 REM
60 !CHR$(11) \ REM  CLEAR SCREEN
70 FILL 3529,183 \ FILL 3569,55 \ REM  INHIBIT LL LIMIT
80 !"ROWS IN TIE-UP AND THREADING PATTERNS ARE NUMBERED FROM",
90 !" BOTTOM"\!"TO TOP.\!\!\!
100 INPUT"NUMBER OF ROWS IN TIE-UP           : ",N1
110 INPUT"NUMBER OF COLUMNS IN TIE-UP      : ",N4
120 INPUT"NUMBER OF COLUMNS IN THREADING   : ",N3
130 INPUT"NUMBER OF ROWS IN TREADLING      : ",N2
140 !\!\!"TYPE THE CHARACTER YOU WANT PRINTED ....."\!
150 !"      USE . FOR FINE THREAD"
160 !"      USE * FOR COARSE THREAD        : ",
170 C$=INCHAR$(0)\!C$\!
180 IF C$="." THEN 210
190 IF C$<>"*" THEN 140
200 N9=7\N8=4\GOTO 220
210 N9=4\N8=2
220 INPUT"NO. HORIZONTAL REPETITIONS DESIRED : ",M5
230 INPUT"NO. VERTICAL REPETITIONS DESIRED  : ",M6
240 DIM A(N1,N4),B(N2,N4),E(N1,N3),F(N2,N3)
250 E9$=CHR$(27)\M9$=E9$+"9"\H8$=E9$+CHR$(83)\L9$=CHR$(10)
260 G9$=E9$+"3"\G8$=E9$+"4"\R9$=CHR$(13)\N9$=E9$+L9$
270 B9$=CHR$(8)
280 !#1,H8$,
290 N7=1\!#1,E9$+CHR$(9)+CHR$(N7),
300 FOR J=1 TO 30\!#1," ",\NEXT\!#1,M9$,
310 N7=45
320 H9$=E9$+CHR$(31)+CHR$(N9)
330 V9$=E9$+CHR$(30)+CHR$(N8)
340 H5$=E9$+CHR$(9)+CHR$(N7)
350 FOR J=1 TO 100\NEXT
360 !#1,H9$,V9$,H5$,
370 !#1,G9$,R9$,
380 GOSUB 730\!\!
390 GOSUB 1020\!\!
400 GOSUB 880
410 !\!"PATTERN COMPUTATIONS IN PROGRESS"
420 GOSUB 1160
430 P=0
440 T=0
450 FOR L=1 TO M6
460 FOR K=1 TO N2
470 FOR M=1 TO N3
480 IF P=0 THEN 510
490 IF F(K,M)=1 THEN !#1," ", ELSE !#1,C$,
500 GOTO 520
510 IF F(K,M)=1 THEN !#1,C$, ELSE!#1," ",
520 NEXT M
530 FOR Q=1 TO 50\NEXT Q
540 !#1,R9$,L9$,
550 FOR Q=1 TO 50\NEXT Q
560 NEXT K

```

Listing 1 continued on page 516

Listing 1 continued:

```

570 NEXT L
580 T=T+1\IF T=M5 THEN 620
590 FOR J=1 TO N3\!#1," ",\NEXT J\!#1,M9$,
600 FOR J=1 TO M6*N2\FOR Q=1 TO 25\NEXT Q
610 !#1,N9$,\NEXT J\GOTO 450
620 P=P+1
630 IF P=2 THEN 680
640 FOR J=1 TO (M5-1)*N3\!#1,B9$,\NEXT\!#1,M9$,
650 V5$=E9$+CHR$(30)+CHR$(9)\!#1,V5$,
660 FOR J=1 TO 5\!#1,L9$,\NEXT\!#1,V9$,
670 GOTO 440
680 !#1,R9$,L9$,G8$,
690 !#1,V5$,H8$,
700 FOR J=1 TO 2\!#1,L9$,\NEXT
710 FILL 3529,184\FILL 3569,184 \ REM RESTORE LL LIMIT
720 END
730 REM SUB TO INPUT A-MATRIX ELEMENTS
740 !CHR$(11)
750 !"TIE-UP ROWS ARE NUMBERED FROM BOTTOM TO TOP."!\!\!
760 !"TYPE '1' FOR THREAD UP ; TYPE '0' FOR THREAD DOWN."!\!\!
770 !"TIE-UP :"\!
780 FOR J=1 TO N4
790 !TAB(10),"COLUMN ",%2I,J
800 FOR I=1 TO N1
810 !TAB(20),"ROW ",%2I,I," : ",
820 A$=INCHAR$(0)\!A$\A(I,J)=VAL(A$)
830 IF A(I,J)=1 THEN 850
840 IF A(I,J)<>0 THEN 810
850 NEXT I\!
860 NEXT J
870 RETURN
880 REM SUB TO INPUT B-MATRIX ELEMENTS
890 !CHR$(11)
900 !"TREADING COLUMNS ARE NUMBERED FROM LEFT TO RIGHT."!\!\!
910 !"TREADING :"\!
920 !"WHICH THREAD IS UP IN ",
930 FOR I=1 TO N2
940 !TAB(23),"ROW ",%2I,I," ? ",
950 T5$=INCHAR$(0)\!T5$\T5=VAL(T5$)
960 IF T5<1 THEN 940
970 IF T5>N4 THEN 940
980 FOR J=1 TO N4
990 IF J=T5 THEN B(I,J)=1 ELSE B(I,J)=0
1000 NEXTJ\NEXTI
1010 RETURN
1020 REM SUB TO INPUT E-MATRIX ELEMENTS
1030 !CHR$(11)
1040 !"THREADING ROWS ARE NUMBERED FROM BOTTOM TO TOP."!\!\!
1050 !"THREADING :"\!
1060 !"WHICH THREAD IS UP IN ",
1070 FOR J=1 TO N3
1080 !TAB(23),"COLUMN ",%2I,J," ? ",
1090 T6$=INCHAR$(0)\!T6$\T6=VAL(T6$)
1100 IF T6<1 THEN 1080
1110 IF T6>N1 THEN 1080
1120 .FOR I=1 TO N1
1130 IF I=T6 THEN E(I,J)=1 ELSE E(I,J)=0
1140 NEXT I\NEXT J

```

Listing 1 continued:

```
1150 RETURN
1160 REM SUB TO COMPUTE PATTERN
1170 FOR I=1 TO N1
1180 FOR J=1 TO N4
1190 IF A(I,J)=0 THEN 1280
1200 FOR K=1 TO N2
1210 IF B(K,J)=0 THEN 1270
1220 FOR M=1 TO N3
1230 IF E(I,M)=0 THEN 1260
1240 F(K,M)=B(K,J)*A(I,J)*E(I,M)
1250 IF F(K,M)=1 THEN F(K,M)=1 ELSE F(K,M)=0
1260 NEXT M
1270 NEXT K
1280 NEXT J
1290 NEXT I
1300 RETURN
```

## BYTE Clearance Sale

The installation of new microcomputer systems at BYTE allows us to sell some of our old equipment. The items for sale have been used for varying lengths of time, but are all in working order (except as noted). All units are sold as is. Prices are FOB Peterborough, New Hampshire.

Three high-performance word-processing subsystems for use with a microcomputer, each consisting of a:

**Scion Screensplitter** memory-mapped S-100-bus video-display board

**Scion** parallel-port keyboard

**Scion Wordsmith** text-editing software

**Ball Corporation** green-phosphor video monitor. The units are all in excellent condition.

Price: \$1200 each, \$3000 takes all three.

**Shaffstall EDI7700** phototypesetter floppy-disk interface for use with Compu-graphic Editwriter-series typesetting equipment, including standard ASCII translation software. (This device reads and writes phototypesetter disks with textual data transmitted or received through a serial RS-232C link.) Excellent condition.

Price: \$8500.

**Pensee Pascal Microengine** computer system, including UCSD Pascal version 3.0, 16-bit microprocessor, two Shugart 800R single-density 8-inch floppy-disk drives, and two RS-232C serial ports. Good condition.

Price: \$2000.

For more information, contact:  
Jon Swanson at BYTE Publications Inc., 70 Main St.,  
Peterborough, NH 03458.

resolution capability prompted me to rewrite the program. This article demonstrates the results. Weavers who have seen the outputs have been amazed at the ease and accuracy with which weaving could be simulated by the microcomputer.

### North Star BASIC Program

WEAVE begins with FILL statements that disable the line length limitation of North Star BASIC. This disabling is necessary to prevent BASIC from inserting carriage returns at unwanted locations. Since you will want to print many more than 132 characters without a carriage return, North Star BASIC's maximum line length of 132 is not enough.

The FILL statements shown apply to a copy of North Star BASIC that has been relocated to memory address 0000. Because the program uses so much memory for the storage of matrix elements, it is not feasible to locate BASIC any higher in memory. In my Processor Technology Sol computer, I use a DOS (disk operating system) that has been relocated to hexadecimal F000 to get it out of the contiguous user-memory area.

---

## Weavers are amazed at how accurately weaving can be simulated by a microcomputer.

---

The program is written around the use of a Diablo 1650 printer. The Escape sequences defined in lines 250 through 270 are used for the various carriage and paper movements required by the program.

Both the treadling (B-matrix) and the threading (E-matrix) are normally elemental building blocks that are repeated many times in the generation of the woven material. These elemental blocks carry all the information required to completely define the resulting pattern. WEAVE requires the user to input only one such block, but the resulting printout can contain as many repetitions of each as desired by changing the variables M5 and M6.

Line 170 of the program permits the user to select either a fine or a coarse weaving pattern corresponding to the use of fine or coarse threads on the loom. Fine patterns are created with the "." character, while coarse ones use the "\*" character. In both cases, the horizontal and vertical incremental spacings for the Diablo are set to appropriate values. Examples of both fine (figure 3) and coarse (figure 1) patterns accompany this article. As you can see, the program will first print out the pattern as it will appear on the front side of the material, then print the back side pattern.

The final pattern is computed in the four nested FOR . . . NEXT loops in lines 1170 through 1290. In the printout (lines 430 through 670), the variable P defines whether the front side or the back side is to be printed. The back side is, of course, simply the negative of the front side.

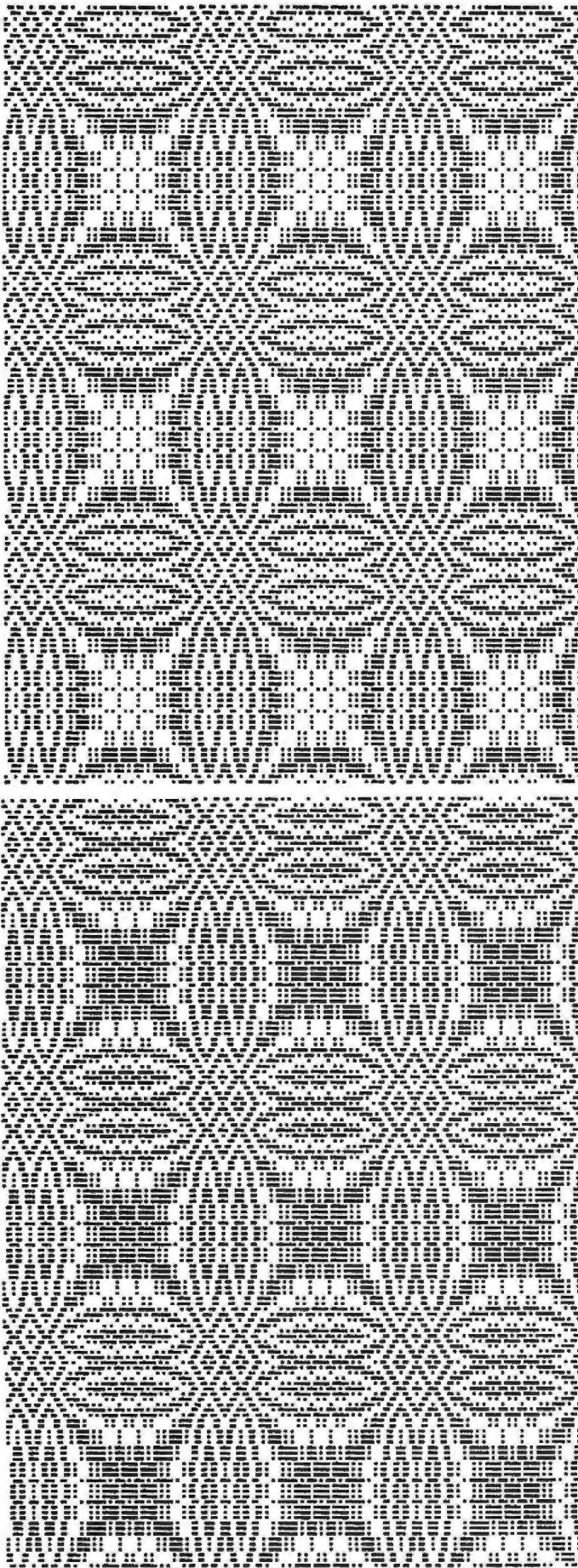

Figure 3: Sample outputs of a fine-thread pattern produced by the WEAVE program. Both front and back patterns are shown.

## Conclusion

It is important to relocate BASIC to an address as low as possible in memory to provide maximum room for the matrices used in WEAVE. Even at a load address of 0000 you will find yourself bumping into the end of memory when you attempt to run very complex patterns. In weaving books you will find complex patterns involving combinations of input matrices as large, for example, as 8 by 8 (for tie-up), 8 by 330 (for threading) and 8 by 150 (for treadling). With one byte for each element in these matrices as well as one byte for each element of the resulting pattern matrix, you would need more than 53K bytes just for the matrix elements.

In a way, this problem points up a significant limitation of BASIC. Each matrix element involved in WEAVE can have only one of two possible values: 1 or 0. But a full 8-bit byte is required to store each element because BASIC cannot easily treat data at the bit level. Although it is beyond my ability, writing WEAVE in machine language would allow the program to handle much larger and more intricate patterns. ■

## Additional Notes

### A-Matrix

The A-matrix is called the tie-up by weavers. It is usually, but not always, a square matrix. It can be 4 by 4, 6 by 6, 8 by 8, 10 by 10, 12 by 12, 16 by 16, or any other size depending only upon the number of harnesses on the loom.

It is usual, but not necessary, for half the threads in each column of the matrix to be "up" and the other half "down." "Up" in the program is indicated by a 1, while "down" is indicated by a 0.

### B-Matrix

The B-matrix is called the foot treadling by weavers. The treadling is very flexible and may actually be changed by the weaver in the course of the weaving process merely by changing the pattern of his foot motions. However, he will normally decide on a treadling pattern (or a succession of such patterns) before starting to weave so as to be able to predict the resulting design in the woven material.

The B-matrix will always have the same number of columns as the A-matrix.

The treadling is normally a repetition of elemental blocks or a repetition of a sequence of such blocks.

### E-Matrix

The E-matrix is called the threading pattern by weavers. It represents the configuration of threads implemented on the loom, and it cannot be easily altered during the weaving process.

The E-matrix contains the same number of rows as the A-matrix and, like the B-matrix, may be made up of repetitive blocks or a repetitive sequence of blocks.

TANTALUM CAPACITORS	LINEAR CIRCUITS	CRYSTALS																																																																																																																																																																																																																																																																																																																																																																																																																		
<table border="1"> <tr><td>100µF</td><td>1.00</td></tr> <tr><td>220µF</td><td>1.50</td></tr> <tr><td>470µF</td><td>2.00</td></tr> <tr><td>1000µF</td><td>3.00</td></tr> <tr><td>2200µF</td><td>4.00</td></tr> <tr><td>4700µF</td><td>5.00</td></tr> <tr><td>10000µF</td><td>6.00</td></tr> <tr><td>22000µF</td><td>7.00</td></tr> <tr><td>47000µF</td><td>8.00</td></tr> <tr><td>100000µF</td><td>9.00</td></tr> <tr><td>220000µF</td><td>10.00</td></tr> <tr><td>470000µF</td><td>11.00</td></tr> <tr><td>1000000µF</td><td>12.00</td></tr> </table>	100µF	1.00	220µF	1.50	470µF	2.00	1000µF	3.00	2200µF	4.00	4700µF	5.00	10000µF	6.00	22000µF	7.00	47000µF	8.00	100000µF	9.00	220000µF	10.00	470000µF	11.00	1000000µF	12.00	<table border="1"> <tr><td>7805</td><td>1.00</td></tr> <tr><td>7809</td><td>1.50</td></tr> <tr><td>7812</td><td>2.00</td></tr> <tr><td>7815</td><td>2.50</td></tr> <tr><td>7818</td><td>3.00</td></tr> <tr><td>7824</td><td>4.00</td></tr> <tr><td>7828</td><td>4.50</td></tr> <tr><td>7830</td><td>5.00</td></tr> <tr><td>7836</td><td>6.00</td></tr> <tr><td>7848</td><td>8.00</td></tr> <tr><td>7805C</td><td>1.00</td></tr> <tr><td>7809C</td><td>1.50</td></tr> <tr><td>7812C</td><td>2.00</td></tr> <tr><td>7815C</td><td>2.50</td></tr> <tr><td>7818C</td><td>3.00</td></tr> <tr><td>7824C</td><td>4.00</td></tr> <tr><td>7828C</td><td>4.50</td></tr> <tr><td>7830C</td><td>5.00</td></tr> <tr><td>7836C</td><td>6.00</td></tr> <tr><td>7848C</td><td>8.00</td></tr> </table>	7805	1.00	7809	1.50	7812	2.00	7815	2.50	7818	3.00	7824	4.00	7828	4.50	7830	5.00	7836	6.00	7848	8.00	7805C	1.00	7809C	1.50	7812C	2.00	7815C	2.50	7818C	3.00	7824C	4.00	7828C	4.50	7830C	5.00	7836C	6.00	7848C	8.00	<table border="1"> <tr><td>3.000</td><td>5.000</td><td>8.000</td></tr> <tr><td>2.000</td><td>3.000</td><td>10.000</td></tr> <tr><td>16.432</td><td>4.000</td><td>14.000</td></tr> <tr><td>20.000</td><td></td><td></td></tr> <tr><td>64.250</td><td></td><td>12.500</td></tr> </table>	3.000	5.000	8.000	2.000	3.000	10.000	16.432	4.000	14.000	20.000			64.250		12.500																																																																																																																																																																																																																																																																																																																																	
100µF	1.00																																																																																																																																																																																																																																																																																																																																																																																																																			
220µF	1.50																																																																																																																																																																																																																																																																																																																																																																																																																			
470µF	2.00																																																																																																																																																																																																																																																																																																																																																																																																																			
1000µF	3.00																																																																																																																																																																																																																																																																																																																																																																																																																			
2200µF	4.00																																																																																																																																																																																																																																																																																																																																																																																																																			
4700µF	5.00																																																																																																																																																																																																																																																																																																																																																																																																																			
10000µF	6.00																																																																																																																																																																																																																																																																																																																																																																																																																			
22000µF	7.00																																																																																																																																																																																																																																																																																																																																																																																																																			
47000µF	8.00																																																																																																																																																																																																																																																																																																																																																																																																																			
100000µF	9.00																																																																																																																																																																																																																																																																																																																																																																																																																			
220000µF	10.00																																																																																																																																																																																																																																																																																																																																																																																																																			
470000µF	11.00																																																																																																																																																																																																																																																																																																																																																																																																																			
1000000µF	12.00																																																																																																																																																																																																																																																																																																																																																																																																																			
7805	1.00																																																																																																																																																																																																																																																																																																																																																																																																																			
7809	1.50																																																																																																																																																																																																																																																																																																																																																																																																																			
7812	2.00																																																																																																																																																																																																																																																																																																																																																																																																																			
7815	2.50																																																																																																																																																																																																																																																																																																																																																																																																																			
7818	3.00																																																																																																																																																																																																																																																																																																																																																																																																																			
7824	4.00																																																																																																																																																																																																																																																																																																																																																																																																																			
7828	4.50																																																																																																																																																																																																																																																																																																																																																																																																																			
7830	5.00																																																																																																																																																																																																																																																																																																																																																																																																																			
7836	6.00																																																																																																																																																																																																																																																																																																																																																																																																																			
7848	8.00																																																																																																																																																																																																																																																																																																																																																																																																																			
7805C	1.00																																																																																																																																																																																																																																																																																																																																																																																																																			
7809C	1.50																																																																																																																																																																																																																																																																																																																																																																																																																			
7812C	2.00																																																																																																																																																																																																																																																																																																																																																																																																																			
7815C	2.50																																																																																																																																																																																																																																																																																																																																																																																																																			
7818C	3.00																																																																																																																																																																																																																																																																																																																																																																																																																			
7824C	4.00																																																																																																																																																																																																																																																																																																																																																																																																																			
7828C	4.50																																																																																																																																																																																																																																																																																																																																																																																																																			
7830C	5.00																																																																																																																																																																																																																																																																																																																																																																																																																			
7836C	6.00																																																																																																																																																																																																																																																																																																																																																																																																																			
7848C	8.00																																																																																																																																																																																																																																																																																																																																																																																																																			
3.000	5.000	8.000																																																																																																																																																																																																																																																																																																																																																																																																																		
2.000	3.000	10.000																																																																																																																																																																																																																																																																																																																																																																																																																		
16.432	4.000	14.000																																																																																																																																																																																																																																																																																																																																																																																																																		
20.000																																																																																																																																																																																																																																																																																																																																																																																																																				
64.250		12.500																																																																																																																																																																																																																																																																																																																																																																																																																		
<table border="1"> <tr><td>DB 25P male</td><td>42.75</td></tr> <tr><td>DB 25P female</td><td>3.75</td></tr> <tr><td>MODGS</td><td>9.50</td></tr> </table>	DB 25P male	42.75	DB 25P female	3.75	MODGS	9.50	<table border="1"> <tr><td>74LS01</td><td>25</td><td>74LS02</td><td>25</td></tr> <tr><td>74LS03</td><td>25</td><td>74LS04</td><td>25</td></tr> <tr><td>74LS05</td><td>25</td><td>74LS06</td><td>25</td></tr> <tr><td>74LS07</td><td>25</td><td>74LS08</td><td>25</td></tr> <tr><td>74LS10</td><td>25</td><td>74LS11</td><td>25</td></tr> <tr><td>74LS12</td><td>25</td><td>74LS13</td><td>25</td></tr> <tr><td>74LS14</td><td>25</td><td>74LS15</td><td>25</td></tr> <tr><td>74LS16</td><td>25</td><td>74LS17</td><td>25</td></tr> <tr><td>74LS18</td><td>25</td><td>74LS19</td><td>25</td></tr> <tr><td>74LS20</td><td>25</td><td>74LS21</td><td>25</td></tr> <tr><td>74LS22</td><td>25</td><td>74LS23</td><td>25</td></tr> <tr><td>74LS24</td><td>25</td><td>74LS25</td><td>25</td></tr> <tr><td>74LS26</td><td>25</td><td>74LS27</td><td>25</td></tr> <tr><td>74LS28</td><td>25</td><td>74LS29</td><td>25</td></tr> <tr><td>74LS30</td><td>25</td><td>74LS31</td><td>25</td></tr> <tr><td>74LS32</td><td>25</td><td>74LS33</td><td>25</td></tr> <tr><td>74LS34</td><td>25</td><td>74LS35</td><td>25</td></tr> <tr><td>74LS36</td><td>25</td><td>74LS37</td><td>25</td></tr> <tr><td>74LS38</td><td>25</td><td>74LS39</td><td>25</td></tr> <tr><td>74LS40</td><td>25</td><td>74LS41</td><td>25</td></tr> <tr><td>74LS42</td><td>25</td><td>74LS43</td><td>25</td></tr> <tr><td>74LS44</td><td>25</td><td>74LS45</td><td>25</td></tr> <tr><td>74LS46</td><td>25</td><td>74LS47</td><td>25</td></tr> <tr><td>74LS48</td><td>25</td><td>74LS49</td><td>25</td></tr> <tr><td>74LS50</td><td>25</td><td>74LS51</td><td>25</td></tr> <tr><td>74LS52</td><td>25</td><td>74LS53</td><td>25</td></tr> <tr><td>74LS54</td><td>25</td><td>74LS55</td><td>25</td></tr> <tr><td>74LS56</td><td>25</td><td>74LS57</td><td>25</td></tr> <tr><td>74LS58</td><td>25</td><td>74LS59</td><td>25</td></tr> <tr><td>74LS60</td><td>25</td><td>74LS61</td><td>25</td></tr> <tr><td>74LS62</td><td>25</td><td>74LS63</td><td>25</td></tr> <tr><td>74LS64</td><td>25</td><td>74LS65</td><td>25</td></tr> <tr><td>74LS66</td><td>25</td><td>74LS67</td><td>25</td></tr> <tr><td>74LS68</td><td>25</td><td>74LS69</td><td>25</td></tr> <tr><td>74LS70</td><td>25</td><td>74LS71</td><td>25</td></tr> <tr><td>74LS72</td><td>25</td><td>74LS73</td><td>25</td></tr> <tr><td>74LS74</td><td>25</td><td>74LS75</td><td>25</td></tr> <tr><td>74LS76</td><td>25</td><td>74LS77</td><td>25</td></tr> <tr><td>74LS78</td><td>25</td><td>74LS79</td><td>25</td></tr> <tr><td>74LS80</td><td>25</td><td>74LS81</td><td>25</td></tr> <tr><td>74LS82</td><td>25</td><td>74LS83</td><td>25</td></tr> <tr><td>74LS84</td><td>25</td><td>74LS85</td><td>25</td></tr> <tr><td>74LS86</td><td>25</td><td>74LS87</td><td>25</td></tr> <tr><td>74LS88</td><td>25</td><td>74LS89</td><td>25</td></tr> <tr><td>74LS90</td><td>25</td><td>74LS91</td><td>25</td></tr> <tr><td>74LS92</td><td>25</td><td>74LS93</td><td>25</td></tr> <tr><td>74LS94</td><td>25</td><td>74LS95</td><td>25</td></tr> <tr><td>74LS96</td><td>25</td><td>74LS97</td><td>25</td></tr> <tr><td>74LS98</td><td>25</td><td>74LS99</td><td>25</td></tr> </table>	74LS01	25	74LS02	25	74LS03	25	74LS04	25	74LS05	25	74LS06	25	74LS07	25	74LS08	25	74LS10	25	74LS11	25	74LS12	25	74LS13	25	74LS14	25	74LS15	25	74LS16	25	74LS17	25	74LS18	25	74LS19	25	74LS20	25	74LS21	25	74LS22	25	74LS23	25	74LS24	25	74LS25	25	74LS26	25	74LS27	25	74LS28	25	74LS29	25	74LS30	25	74LS31	25	74LS32	25	74LS33	25	74LS34	25	74LS35	25	74LS36	25	74LS37	25	74LS38	25	74LS39	25	74LS40	25	74LS41	25	74LS42	25	74LS43	25	74LS44	25	74LS45	25	74LS46	25	74LS47	25	74LS48	25	74LS49	25	74LS50	25	74LS51	25	74LS52	25	74LS53	25	74LS54	25	74LS55	25	74LS56	25	74LS57	25	74LS58	25	74LS59	25	74LS60	25	74LS61	25	74LS62	25	74LS63	25	74LS64	25	74LS65	25	74LS66	25	74LS67	25	74LS68	25	74LS69	25	74LS70	25	74LS71	25	74LS72	25	74LS73	25	74LS74	25	74LS75	25	74LS76	25	74LS77	25	74LS78	25	74LS79	25	74LS80	25	74LS81	25	74LS82	25	74LS83	25	74LS84	25	74LS85	25	74LS86	25	74LS87	25	74LS88	25	74LS89	25	74LS90	25	74LS91	25	74LS92	25	74LS93	25	74LS94	25	74LS95	25	74LS96	25	74LS97	25	74LS98	25	74LS99	25	<table border="1"> <tr><td>74LS00</td><td>25</td><td>74LS01</td><td>25</td></tr> <tr><td>74LS02</td><td>25</td><td>74LS03</td><td>25</td></tr> <tr><td>74LS04</td><td>25</td><td>74LS05</td><td>25</td></tr> <tr><td>74LS06</td><td>25</td><td>74LS07</td><td>25</td></tr> <tr><td>74LS08</td><td>25</td><td>74LS09</td><td>25</td></tr> <tr><td>74LS10</td><td>25</td><td>74LS11</td><td>25</td></tr> <tr><td>74LS12</td><td>25</td><td>74LS13</td><td>25</td></tr> <tr><td>74LS14</td><td>25</td><td>74LS15</td><td>25</td></tr> <tr><td>74LS16</td><td>25</td><td>74LS17</td><td>25</td></tr> <tr><td>74LS18</td><td>25</td><td>74LS19</td><td>25</td></tr> <tr><td>74LS20</td><td>25</td><td>74LS21</td><td>25</td></tr> <tr><td>74LS22</td><td>25</td><td>74LS23</td><td>25</td></tr> <tr><td>74LS24</td><td>25</td><td>74LS25</td><td>25</td></tr> <tr><td>74LS26</td><td>25</td><td>74LS27</td><td>25</td></tr> <tr><td>74LS28</td><td>25</td><td>74LS29</td><td>25</td></tr> <tr><td>74LS30</td><td>25</td><td>74LS31</td><td>25</td></tr> <tr><td>74LS32</td><td>25</td><td>74LS33</td><td>25</td></tr> <tr><td>74LS34</td><td>25</td><td>74LS35</td><td>25</td></tr> <tr><td>74LS36</td><td>25</td><td>74LS37</td><td>25</td></tr> <tr><td>74LS38</td><td>25</td><td>74LS39</td><td>25</td></tr> <tr><td>74LS40</td><td>25</td><td>74LS41</td><td>25</td></tr> <tr><td>74LS42</td><td>25</td><td>74LS43</td><td>25</td></tr> <tr><td>74LS44</td><td>25</td><td>74LS45</td><td>25</td></tr> <tr><td>74LS46</td><td>25</td><td>74LS47</td><td>25</td></tr> <tr><td>74LS48</td><td>25</td><td>74LS49</td><td>25</td></tr> <tr><td>74LS50</td><td>25</td><td>74LS51</td><td>25</td></tr> <tr><td>74LS52</td><td>25</td><td>74LS53</td><td>25</td></tr> <tr><td>74LS54</td><td>25</td><td>74LS55</td><td>25</td></tr> <tr><td>74LS56</td><td>25</td><td>74LS57</td><td>25</td></tr> <tr><td>74LS58</td><td>25</td><td>74LS59</td><td>25</td></tr> <tr><td>74LS60</td><td>25</td><td>74LS61</td><td>25</td></tr> <tr><td>74LS62</td><td>25</td><td>74LS63</td><td>25</td></tr> <tr><td>74LS64</td><td>25</td><td>74LS65</td><td>25</td></tr> <tr><td>74LS66</td><td>25</td><td>74LS67</td><td>25</td></tr> <tr><td>74LS68</td><td>25</td><td>74LS69</td><td>25</td></tr> <tr><td>74LS70</td><td>25</td><td>74LS71</td><td>25</td></tr> <tr><td>74LS72</td><td>25</td><td>74LS73</td><td>25</td></tr> <tr><td>74LS74</td><td>25</td><td>74LS75</td><td>25</td></tr> <tr><td>74LS76</td><td>25</td><td>74LS77</td><td>25</td></tr> <tr><td>74LS78</td><td>25</td><td>74LS79</td><td>25</td></tr> <tr><td>74LS80</td><td>25</td><td>74LS81</td><td>25</td></tr> <tr><td>74LS82</td><td>25</td><td>74LS83</td><td>25</td></tr> <tr><td>74LS84</td><td>25</td><td>74LS85</td><td>25</td></tr> <tr><td>74LS86</td><td>25</td><td>74LS87</td><td>25</td></tr> <tr><td>74LS88</td><td>25</td><td>74LS89</td><td>25</td></tr> <tr><td>74LS90</td><td>25</td><td>74LS91</td><td>25</td></tr> <tr><td>74LS92</td><td>25</td><td>74LS93</td><td>25</td></tr> <tr><td>74LS94</td><td>25</td><td>74LS95</td><td>25</td></tr> <tr><td>74LS96</td><td>25</td><td>74LS97</td><td>25</td></tr> <tr><td>74LS98</td><td>25</td><td>74LS99</td><td>25</td></tr> </table>	74LS00	25	74LS01	25	74LS02	25	74LS03	25	74LS04	25	74LS05	25	74LS06	25	74LS07	25	74LS08	25	74LS09	25	74LS10	25	74LS11	25	74LS12	25	74LS13	25	74LS14	25	74LS15	25	74LS16	25	74LS17	25	74LS18	25	74LS19	25	74LS20	25	74LS21	25	74LS22	25	74LS23	25	74LS24	25	74LS25	25	74LS26	25	74LS27	25	74LS28	25	74LS29	25	74LS30	25	74LS31	25	74LS32	25	74LS33	25	74LS34	25	74LS35	25	74LS36	25	74LS37	25	74LS38	25	74LS39	25	74LS40	25	74LS41	25	74LS42	25	74LS43	25	74LS44	25	74LS45	25	74LS46	25	74LS47	25	74LS48	25	74LS49	25	74LS50	25	74LS51	25	74LS52	25	74LS53	25	74LS54	25	74LS55	25	74LS56	25	74LS57	25	74LS58	25	74LS59	25	74LS60	25	74LS61	25	74LS62	25	74LS63	25	74LS64	25	74LS65	25	74LS66	25	74LS67	25	74LS68	25	74LS69	25	74LS70	25	74LS71	25	74LS72	25	74LS73	25	74LS74	25	74LS75	25	74LS76	25	74LS77	25	74LS78	25	74LS79	25	74LS80	25	74LS81	25	74LS82	25	74LS83	25	74LS84	25	74LS85	25	74LS86	25	74LS87	25	74LS88	25	74LS89	25	74LS90	25	74LS91	25	74LS92	25	74LS93	25	74LS94	25	74LS95	25	74LS96	25	74LS97	25	74LS98	25	74LS99	25
DB 25P male	42.75																																																																																																																																																																																																																																																																																																																																																																																																																			
DB 25P female	3.75																																																																																																																																																																																																																																																																																																																																																																																																																			
MODGS	9.50																																																																																																																																																																																																																																																																																																																																																																																																																			
74LS01	25	74LS02	25																																																																																																																																																																																																																																																																																																																																																																																																																	
74LS03	25	74LS04	25																																																																																																																																																																																																																																																																																																																																																																																																																	
74LS05	25	74LS06	25																																																																																																																																																																																																																																																																																																																																																																																																																	
74LS07	25	74LS08	25																																																																																																																																																																																																																																																																																																																																																																																																																	
74LS10	25	74LS11	25																																																																																																																																																																																																																																																																																																																																																																																																																	
74LS12	25	74LS13	25																																																																																																																																																																																																																																																																																																																																																																																																																	
74LS14	25	74LS15	25																																																																																																																																																																																																																																																																																																																																																																																																																	
74LS16	25	74LS17	25																																																																																																																																																																																																																																																																																																																																																																																																																	
74LS18	25	74LS19	25																																																																																																																																																																																																																																																																																																																																																																																																																	
74LS20	25	74LS21	25																																																																																																																																																																																																																																																																																																																																																																																																																	
74LS22	25	74LS23	25																																																																																																																																																																																																																																																																																																																																																																																																																	
74LS24	25	74LS25	25																																																																																																																																																																																																																																																																																																																																																																																																																	
74LS26	25	74LS27	25																																																																																																																																																																																																																																																																																																																																																																																																																	
74LS28	25	74LS29	25																																																																																																																																																																																																																																																																																																																																																																																																																	
74LS30	25	74LS31	25																																																																																																																																																																																																																																																																																																																																																																																																																	
74LS32	25	74LS33	25																																																																																																																																																																																																																																																																																																																																																																																																																	
74LS34	25	74LS35	25																																																																																																																																																																																																																																																																																																																																																																																																																	
74LS36	25	74LS37	25																																																																																																																																																																																																																																																																																																																																																																																																																	
74LS38	25	74LS39	25																																																																																																																																																																																																																																																																																																																																																																																																																	
74LS40	25	74LS41	25																																																																																																																																																																																																																																																																																																																																																																																																																	
74LS42	25	74LS43	25																																																																																																																																																																																																																																																																																																																																																																																																																	
74LS44	25	74LS45	25																																																																																																																																																																																																																																																																																																																																																																																																																	
74LS46	25	74LS47	25																																																																																																																																																																																																																																																																																																																																																																																																																	
74LS48	25	74LS49	25																																																																																																																																																																																																																																																																																																																																																																																																																	
74LS50	25	74LS51	25																																																																																																																																																																																																																																																																																																																																																																																																																	
74LS52	25	74LS53	25																																																																																																																																																																																																																																																																																																																																																																																																																	
74LS54	25	74LS55	25																																																																																																																																																																																																																																																																																																																																																																																																																	
74LS56	25	74LS57	25																																																																																																																																																																																																																																																																																																																																																																																																																	
74LS58	25	74LS59	25																																																																																																																																																																																																																																																																																																																																																																																																																	
74LS60	25	74LS61	25																																																																																																																																																																																																																																																																																																																																																																																																																	
74LS62	25	74LS63	25																																																																																																																																																																																																																																																																																																																																																																																																																	
74LS64	25	74LS65	25																																																																																																																																																																																																																																																																																																																																																																																																																	
74LS66	25	74LS67	25																																																																																																																																																																																																																																																																																																																																																																																																																	
74LS68	25	74LS69	25																																																																																																																																																																																																																																																																																																																																																																																																																	
74LS70	25	74LS71	25																																																																																																																																																																																																																																																																																																																																																																																																																	
74LS72	25	74LS73	25																																																																																																																																																																																																																																																																																																																																																																																																																	
74LS74	25	74LS75	25																																																																																																																																																																																																																																																																																																																																																																																																																	
74LS76	25	74LS77	25																																																																																																																																																																																																																																																																																																																																																																																																																	
74LS78	25	74LS79	25																																																																																																																																																																																																																																																																																																																																																																																																																	
74LS80	25	74LS81	25																																																																																																																																																																																																																																																																																																																																																																																																																	
74LS82	25	74LS83	25																																																																																																																																																																																																																																																																																																																																																																																																																	
74LS84	25	74LS85	25																																																																																																																																																																																																																																																																																																																																																																																																																	
74LS86	25	74LS87	25																																																																																																																																																																																																																																																																																																																																																																																																																	
74LS88	25	74LS89	25																																																																																																																																																																																																																																																																																																																																																																																																																	
74LS90	25	74LS91	25																																																																																																																																																																																																																																																																																																																																																																																																																	
74LS92	25	74LS93	25																																																																																																																																																																																																																																																																																																																																																																																																																	
74LS94	25	74LS95	25																																																																																																																																																																																																																																																																																																																																																																																																																	
74LS96	25	74LS97	25																																																																																																																																																																																																																																																																																																																																																																																																																	
74LS98	25	74LS99	25																																																																																																																																																																																																																																																																																																																																																																																																																	
74LS00	25	74LS01	25																																																																																																																																																																																																																																																																																																																																																																																																																	
74LS02	25	74LS03	25																																																																																																																																																																																																																																																																																																																																																																																																																	
74LS04	25	74LS05	25																																																																																																																																																																																																																																																																																																																																																																																																																	
74LS06	25	74LS07	25																																																																																																																																																																																																																																																																																																																																																																																																																	
74LS08	25	74LS09	25																																																																																																																																																																																																																																																																																																																																																																																																																	
74LS10	25	74LS11	25																																																																																																																																																																																																																																																																																																																																																																																																																	
74LS12	25	74LS13	25																																																																																																																																																																																																																																																																																																																																																																																																																	
74LS14	25	74LS15	25																																																																																																																																																																																																																																																																																																																																																																																																																	
74LS16	25	74LS17	25																																																																																																																																																																																																																																																																																																																																																																																																																	
74LS18	25	74LS19	25																																																																																																																																																																																																																																																																																																																																																																																																																	
74LS20	25	74LS21	25																																																																																																																																																																																																																																																																																																																																																																																																																	
74LS22	25	74LS23	25																																																																																																																																																																																																																																																																																																																																																																																																																	
74LS24	25	74LS25	25																																																																																																																																																																																																																																																																																																																																																																																																																	
74LS26	25	74LS27	25																																																																																																																																																																																																																																																																																																																																																																																																																	
74LS28	25	74LS29	25																																																																																																																																																																																																																																																																																																																																																																																																																	
74LS30	25	74LS31	25																																																																																																																																																																																																																																																																																																																																																																																																																	
74LS32	25	74LS33	25																																																																																																																																																																																																																																																																																																																																																																																																																	
74LS34	25	74LS35	25																																																																																																																																																																																																																																																																																																																																																																																																																	
74LS36	25	74LS37	25																																																																																																																																																																																																																																																																																																																																																																																																																	
74LS38	25	74LS39	25																																																																																																																																																																																																																																																																																																																																																																																																																	
74LS40	25	74LS41	25																																																																																																																																																																																																																																																																																																																																																																																																																	
74LS42	25	74LS43	25																																																																																																																																																																																																																																																																																																																																																																																																																	
74LS44	25	74LS45	25																																																																																																																																																																																																																																																																																																																																																																																																																	
74LS46	25	74LS47	25																																																																																																																																																																																																																																																																																																																																																																																																																	
74LS48	25	74LS49	25																																																																																																																																																																																																																																																																																																																																																																																																																	
74LS50	25	74LS51	25																																																																																																																																																																																																																																																																																																																																																																																																																	
74LS52	25	74LS53	25																																																																																																																																																																																																																																																																																																																																																																																																																	
74LS54	25	74LS55	25																																																																																																																																																																																																																																																																																																																																																																																																																	
74LS56	25	74LS57	25																																																																																																																																																																																																																																																																																																																																																																																																																	
74LS58	25	74LS59	25																																																																																																																																																																																																																																																																																																																																																																																																																	
74LS60	25	74LS61	25																																																																																																																																																																																																																																																																																																																																																																																																																	
74LS62	25	74LS63	25																																																																																																																																																																																																																																																																																																																																																																																																																	
74LS64	25	74LS65	25																																																																																																																																																																																																																																																																																																																																																																																																																	
74LS66	25	74LS67	25																																																																																																																																																																																																																																																																																																																																																																																																																	
74LS68	25	74LS69	25																																																																																																																																																																																																																																																																																																																																																																																																																	
74LS70	25	74LS71	25																																																																																																																																																																																																																																																																																																																																																																																																																	
74LS72	25	74LS73	25																																																																																																																																																																																																																																																																																																																																																																																																																	
74LS74	25	74LS75	25																																																																																																																																																																																																																																																																																																																																																																																																																	
74LS76	25	74LS77	25																																																																																																																																																																																																																																																																																																																																																																																																																	
74LS78	25	74LS79	25																																																																																																																																																																																																																																																																																																																																																																																																																	
74LS80	25	74LS81	25																																																																																																																																																																																																																																																																																																																																																																																																																	
74LS82	25	74LS83	25																																																																																																																																																																																																																																																																																																																																																																																																																	
74LS84	25	74LS85	25																																																																																																																																																																																																																																																																																																																																																																																																																	
74LS86	25	74LS87	25																																																																																																																																																																																																																																																																																																																																																																																																																	
74LS88	25	74LS89	25																																																																																																																																																																																																																																																																																																																																																																																																																	
74LS90	25	74LS91	25																																																																																																																																																																																																																																																																																																																																																																																																																	
74LS92	25	74LS93	25																																																																																																																																																																																																																																																																																																																																																																																																																	
74LS94	25	74LS95	25																																																																																																																																																																																																																																																																																																																																																																																																																	
74LS96	25	74LS97	25																																																																																																																																																																																																																																																																																																																																																																																																																	
74LS98	25	74LS99	25																																																																																																																																																																																																																																																																																																																																																																																																																	
<table border="1"> <tr><td>74LS00</td><td>25</td><td>74LS01</td><td>25</td></tr> <tr><td>74LS02</td><td>25</td><td>74LS03</td><td>25</td></tr> <tr><td>74LS04</td><td>25</td><td>74LS05</td><td>25</td></tr> <tr><td>74LS06</td><td>25</td><td>74LS07</td><td>25</td></tr> <tr><td>74LS08</td><td>25</td><td>74LS09</td><td>25</td></tr> <tr><td>74LS10</td><td>25</td><td>74LS11</td><td>25</td></tr> <tr><td>74LS12</td><td>25</td><td>74LS13</td><td>25</td></tr> <tr><td>74LS14</td><td>25</td><td>74LS15</td><td>25</td></tr> <tr><td>74LS16</td><td>25</td><td>74LS17</td><td>25</td></tr> <tr><td>74LS18</td><td>25</td><td>74LS19</td><td>25</td></tr> <tr><td>74LS20</td><td>25</td><td>74LS21</td><td>25</td></tr> <tr><td>74LS22</td><td>25</td><td>74LS23</td><td>25</td></tr> <tr><td>74LS24</td><td>25</td><td>74LS25</td><td>25</td></tr> <tr><td>74LS26</td><td>25</td><td>74LS27</td><td>25</td></tr> <tr><td>74LS28</td><td>25</td><td>74LS29</td><td>25</td></tr> <tr><td>74LS30</td><td>25</td><td>74LS31</td><td>25</td></tr> <tr><td>74LS32</td><td>25</td><td>74LS33</td><td>25</td></tr> <tr><td>74LS34</td><td>25</td><td>74LS35</td><td>25</td></tr> <tr><td>74LS36</td><td>25</td><td>74LS37</td><td>25</td></tr> <tr><td>74LS38</td><td>25</td><td>74LS39</td><td>25</td></tr> <tr><td>74LS40</td><td>25</td><td>74LS41</td><td>25</td></tr> <tr><td>74LS42</td><td>25</td><td>74LS43</td><td>25</td></tr> <tr><td>74LS44</td><td>25</td><td>74LS45</td><td>25</td></tr> <tr><td>74LS46</td><td>25</td><td>74LS47</td><td>25</td></tr> <tr><td>74LS48</td><td>25</td><td>74LS49</td><td>25</td></tr> <tr><td>74LS50</td><td>25</td><td>74LS51</td><td>25</td></tr> <tr><td>74LS52</td><td>25</td><td>74LS53</td><td>25</td></tr> <tr><td>74LS54</td><td>25</td><td>74LS55</td><td>25</td></tr> <tr><td>74LS56</td><td>25</td><td>74LS57</td><td>25</td></tr> <tr><td>74LS58</td><td>25</td><td>74LS59</td><td>25</td></tr> <tr><td>74LS60</td><td>25</td><td>74LS61</td><td>25</td></tr> <tr><td>74LS62</td><td>25</td><td>74LS63</td><td>25</td></tr> <tr><td>74LS64</td><td>25</td><td>74LS65</td><td>25</td></tr> <tr><td>74LS66</td><td>25</td><td>74LS67</td><td>25</td></tr> <tr><td>74LS68</td><td>25</td><td>74LS69</td><td>25</td></tr> <tr><td>74LS70</td><td>25</td><td>74LS71</td><td>25</td></tr> <tr><td>74LS72</td><td>25</td><td>74LS73</td><td>25</td></tr> <tr><td>74LS74</td><td>25</td><td>74LS75</td><td>25</td></tr> <tr><td>74LS76</td><td>25</td><td>74LS77</td><td>25</td></tr> <tr><td>74LS78</td><td>25</td><td>74LS79</td><td>25</td></tr> <tr><td>74LS80</td><td>25</td><td>74LS81</td><td>25</td></tr> <tr><td>74LS82</td><td>25</td><td>74LS83</td><td>25</td></tr> <tr><td>74LS84</td><td>25</td><td>74LS85</td><td>25</td></tr> <tr><td>74LS86</td><td>25</td><td>74LS87</td><td>25</td></tr> <tr><td>74LS88</td><td>25</td><td>74LS89</td><td>25</td></tr> <tr><td>74LS90</td><td>25</td><td>74LS91</td><td>25</td></tr> <tr><td>74LS92</td><td>25</td><td>74LS93</td><td>25</td></tr> <tr><td>74LS94</td><td>25</td><td>74LS95</td><td>25</td></tr> <tr><td>74LS96</td><td>25</td><td>74LS97</td><td>25</td></tr> <tr><td>74LS98</td><td>25</td><td>74LS99</td><td>25</td></tr> </table>	74LS00	25	74LS01	25	74LS02	25	74LS03	25	74LS04	25	74LS05	25	74LS06	25	74LS07	25	74LS08	25	74LS09	25	74LS10	25	74LS11	25	74LS12	25	74LS13	25	74LS14	25	74LS15	25	74LS16	25	74LS17	25	74LS18	25	74LS19	25	74LS20	25	74LS21	25	74LS22	25	74LS23	25	74LS24	25	74LS25	25	74LS26	25	74LS27	25	74LS28	25	74LS29	25	74LS30	25	74LS31	25	74LS32	25	74LS33	25	74LS34	25	74LS35	25	74LS36	25	74LS37	25	74LS38	25	74LS39	25	74LS40	25	74LS41	25	74LS42	25	74LS43	25	74LS44	25	74LS45	25	74LS46	25	74LS47	25	74LS48	25	74LS49	25	74LS50	25	74LS51	25	74LS52	25	74LS53	25	74LS54	25	74LS55	25	74LS56	25	74LS57	25	74LS58	25	74LS59	25	74LS60	25	74LS61	25	74LS62	25	74LS63	25	74LS64	25	74LS65	25	74LS66	25	74LS67	25	74LS68	25	74LS69	25	74LS70	25	74LS71	25	74LS72	25	74LS73	25	74LS74	25	74LS75	25	74LS76	25	74LS77	25	74LS78	25	74LS79	25	74LS80	25	74LS81	25	74LS82	25	74LS83	25	74LS84	25	74LS85	25	74LS86	25	74LS87	25	74LS88	25	74LS89	25	74LS90	25	74LS91	25	74LS92	25	74LS93	25	74LS94	25	74LS95	25	74LS96	25	74LS97	25	74LS98	25	74LS99	25	<table border="1"> <tr><td>74LS00</td><td>25</td><td>74LS01</td><td>25</td></tr> <tr><td>74LS02</td><td>25</td><td>74LS03</td><td>25</td></tr> <tr><td>74LS04</td><td>25</td><td>74LS05</td><td>25</td></tr> <tr><td>74LS06</td><td>25</td><td>74LS07</td><td>25</td></tr> <tr><td>74LS08</td><td>25</td><td>74LS09</td><td>25</td></tr> <tr><td>74LS10</td><td>25</td><td>74LS11</td><td>25</td></tr> <tr><td>74LS12</td><td>25</td><td>74LS13</td><td>25</td></tr> <tr><td>74LS14</td><td>25</td><td>74LS15</td><td>25</td></tr> <tr><td>74LS16</td><td>25</td><td>74LS17</td><td>25</td></tr> <tr><td>74LS18</td><td>25</td><td>74LS19</td><td>25</td></tr> <tr><td>74LS20</td><td>25</td><td>74LS21</td><td>25</td></tr> <tr><td>74LS22</td><td>25</td><td>74LS23</td><td>25</td></tr> <tr><td>74LS24</td><td>25</td><td>74LS25</td><td>25</td></tr> <tr><td>74LS26</td><td>25</td><td>74LS27</td><td>25</td></tr> <tr><td>74LS28</td><td>25</td><td>74LS29</td><td>25</td></tr> <tr><td>74LS30</td><td>25</td><td>74LS31</td><td>25</td></tr> <tr><td>74LS32</td><td>25</td><td>74LS33</td><td>25</td></tr> <tr><td>74LS34</td><td>25</td><td>74LS35</td><td>25</td></tr> <tr><td>74LS36</td><td>25</td><td>74LS37</td><td>25</td></tr> <tr><td>74LS38</td><td>25</td><td>74LS39</td><td>25</td></tr> <tr><td>74LS40</td><td>25</td><td>74LS41</td><td>25</td></tr> <tr><td>74LS42</td><td>25</td><td>74LS43</td><td>25</td></tr> <tr><td>74LS44</td><td>25</td><td>74LS45</td><td>25</td></tr> <tr><td>74LS46</td><td>25</td><td>74LS47</td><td>25</td></tr> <tr><td>74LS48</td><td>25</td><td>74LS49</td><td>25</td></tr> <tr><td>74LS50</td><td>25</td><td>74LS51</td><td>25</td></tr> <tr><td>74LS52</td><td>25</td><td>74LS53</td><td>25</td></tr> <tr><td>74LS54</td><td>25</td><td>74LS55</td><td>25</td></tr> <tr><td>74LS56</td><td>25</td><td>74LS57</td><td>25</td></tr> <tr><td>74LS58</td><td>25</td><td>74LS59</td><td>25</td></tr> <tr><td>74LS60</td><td>25</td><td>74LS61</td><td>25</td></tr> <tr><td>74LS62</td><td>25</td><td>74LS63</td><td>25</td></tr> <tr><td>74LS64</td><td>25</td><td>74LS65</td><td>25</td></tr> <tr><td>74LS66</td><td>25</td><td>74LS67</td><td>25</td></tr> <tr><td>74LS68</td><td>25</td><td>74LS69</td><td>25</td></tr> <tr><td>74LS70</td><td>25</td><td>74LS71</td><td>25</td></tr> <tr><td>74LS72</td><td>25</td><td>74LS73</td><td>25</td></tr> <tr><td>74LS74</td><td>25</td><td>74LS75</td><td>25</td></tr> <tr><td>74LS76</td><td>25</td><td>74LS77</td><td>25</td></tr> <tr><td>74LS78</td><td>25</td><td>74LS79</td><td>25</td></tr> <tr><td>74LS80</td><td>25</td><td>74LS81</td><td>25</td></tr> <tr><td>74LS82</td><td>25</td><td>74LS83</td><td>25</td></tr> <tr><td>74LS84</td><td>25</td><td>74LS85</td><td>25</td></tr> <tr><td>74LS86</td><td>25</td><td>74LS87</td><td>25</td></tr> <tr><td>74LS88</td><td>25</td><td>74LS89</td><td>25</td></tr> <tr><td>74LS90</td><td>25</td><td>74LS91</td><td>25</td></tr> <tr><td>74LS92</td><td>25</td><td>74LS93</td><td>25</td></tr> <tr><td>74LS94</td><td>25</td><td>74LS95</td><td>25</td></tr> <tr><td>74LS96</td><td>25</td><td>74LS97</td><td>25</td></tr> <tr><td>74LS98</td><td>25</td><td>74LS99</td><td>25</td></tr> </table>	74LS00	25	74LS01	25	74LS02	25	74LS03	25	74LS04	25	74LS05	25	74LS06	25	74LS07	25	74LS08	25	74LS09	25	74LS10	25	74LS11	25	74LS12	25	74LS13	25	74LS14	25	74LS15	25	74LS16	25	74LS17	25	74LS18	25	74LS19	25	74LS20	25	74LS21	25	74LS22	25	74LS23	25	74LS24	25	74LS25	25	74LS26	25	74LS27	25	74LS28	25	74LS29	25	74LS30	25	74LS31	25	74LS32	25	74LS33	25	74LS34	25	74LS35	25	74LS36	25	74LS37	25	74LS38	25	74LS39	25	74LS40	25	74LS41	25	74LS42	25	74LS43	25	74LS44	25	74LS45	25	74LS46	25	74LS47	25	74LS48	25	74LS49	25	74LS50	25	74LS51	25	74LS52	25	74LS53	25	74LS54	25	74LS55	25	74LS56	25	74LS57	25	74LS58	25	74LS59	25	74LS60	25	74LS61	25	74LS62	25	74LS63	25	74LS64	25	74LS65	25	74LS66	25	74LS67	25	74LS68	25	74LS69	25	74LS70	25	74LS71	25	74LS72	25	74LS73	25	74LS74	25	74LS75	25	74LS76	25	74LS77	25	74LS78	25	74LS79	25	74LS80	25	74LS81	25	74LS82	25	74LS83	25	74LS84	25	74LS85	25	74LS86	25	74LS87	25	74LS88	25	74LS89	25	74LS90	25	74LS91	25	74LS92	25	74LS93	25	74LS94	25	74LS95	25	74LS96	25	74LS97	25	74LS98	25	74LS99	25			
74LS00	25	74LS01	25																																																																																																																																																																																																																																																																																																																																																																																																																	
74LS02	25	74LS03	25																																																																																																																																																																																																																																																																																																																																																																																																																	
74LS04	25	74LS05	25																																																																																																																																																																																																																																																																																																																																																																																																																	
74LS06	25	74LS07	25																																																																																																																																																																																																																																																																																																																																																																																																																	
74LS08	25	74LS09	25																																																																																																																																																																																																																																																																																																																																																																																																																	
74LS10	25	74LS11	25																																																																																																																																																																																																																																																																																																																																																																																																																	
74LS12	25	74LS13	25																																																																																																																																																																																																																																																																																																																																																																																																																	
74LS14	25	74LS15	25																																																																																																																																																																																																																																																																																																																																																																																																																	
74LS16	25	74LS17	25																																																																																																																																																																																																																																																																																																																																																																																																																	
74LS18	25	74LS19	25																																																																																																																																																																																																																																																																																																																																																																																																																	
74LS20	25	74LS21	25																																																																																																																																																																																																																																																																																																																																																																																																																	
74LS22	25	74LS23	25																																																																																																																																																																																																																																																																																																																																																																																																																	
74LS24	25	74LS25	25																																																																																																																																																																																																																																																																																																																																																																																																																	
74LS26	25	74LS27	25																																																																																																																																																																																																																																																																																																																																																																																																																	
74LS28	25	74LS29	25																																																																																																																																																																																																																																																																																																																																																																																																																	
74LS30	25	74LS31	25																																																																																																																																																																																																																																																																																																																																																																																																																	
74LS32	25	74LS33	25																																																																																																																																																																																																																																																																																																																																																																																																																	
74LS34	25	74LS35	25																																																																																																																																																																																																																																																																																																																																																																																																																	
74LS36	25	74LS37	25																																																																																																																																																																																																																																																																																																																																																																																																																	
74LS38	25	74LS39	25																																																																																																																																																																																																																																																																																																																																																																																																																	
74LS40	25	74LS41	25																																																																																																																																																																																																																																																																																																																																																																																																																	
74LS42	25	74LS43	25																																																																																																																																																																																																																																																																																																																																																																																																																	
74LS44	25	74LS45	25																																																																																																																																																																																																																																																																																																																																																																																																																	
74LS46	25	74LS47	25																																																																																																																																																																																																																																																																																																																																																																																																																	
74LS48	25	74LS49	25																																																																																																																																																																																																																																																																																																																																																																																																																	
74LS50	25	74LS51	25																																																																																																																																																																																																																																																																																																																																																																																																																	
74LS52	25	74LS53	25																																																																																																																																																																																																																																																																																																																																																																																																																	
74LS54	25	74LS55	25																																																																																																																																																																																																																																																																																																																																																																																																																	
74LS56	25	74LS57	25																																																																																																																																																																																																																																																																																																																																																																																																																	
74LS58	25	74LS59	25																																																																																																																																																																																																																																																																																																																																																																																																																	
74LS60	25	74LS61	25																																																																																																																																																																																																																																																																																																																																																																																																																	
74LS62	25	74LS63	25																																																																																																																																																																																																																																																																																																																																																																																																																	
74LS64	25	74LS65	25																																																																																																																																																																																																																																																																																																																																																																																																																	
74LS66	25	74LS67	25																																																																																																																																																																																																																																																																																																																																																																																																																	
74LS68	25	74LS69	25																																																																																																																																																																																																																																																																																																																																																																																																																	
74LS70	25	74LS71	25																																																																																																																																																																																																																																																																																																																																																																																																																	
74LS72	25	74LS73	25																																																																																																																																																																																																																																																																																																																																																																																																																	
74LS74	25	74LS75	25																																																																																																																																																																																																																																																																																																																																																																																																																	
74LS76	25	74LS77	25																																																																																																																																																																																																																																																																																																																																																																																																																	
74LS78	25	74LS79	25																																																																																																																																																																																																																																																																																																																																																																																																																	
74LS80	25	74LS81	25																																																																																																																																																																																																																																																																																																																																																																																																																	
74LS82	25	74LS83	25																																																																																																																																																																																																																																																																																																																																																																																																																	
74LS84	25	74LS85	25																																																																																																																																																																																																																																																																																																																																																																																																																	
74LS86	25	74LS87	25																																																																																																																																																																																																																																																																																																																																																																																																																	
74LS88	25	74LS89	25																																																																																																																																																																																																																																																																																																																																																																																																																	
74LS90	25	74LS91	25																																																																																																																																																																																																																																																																																																																																																																																																																	
74LS92	25	74LS93	25																																																																																																																																																																																																																																																																																																																																																																																																																	
74LS94	25	74LS95	25																																																																																																																																																																																																																																																																																																																																																																																																																	
74LS96	25	74LS97	25																																																																																																																																																																																																																																																																																																																																																																																																																	
74LS98	25	74LS99	25																																																																																																																																																																																																																																																																																																																																																																																																																	
74LS00	25	74LS01	25																																																																																																																																																																																																																																																																																																																																																																																																																	
74LS02	25	74LS03	25																																																																																																																																																																																																																																																																																																																																																																																																																	
74LS04	25	74LS05	25																																																																																																																																																																																																																																																																																																																																																																																																																	
74LS06	25	74LS07	25																																																																																																																																																																																																																																																																																																																																																																																																																	
74LS08	25	74LS09	25																																																																																																																																																																																																																																																																																																																																																																																																																	
74LS10	25	74LS11	25																																																																																																																																																																																																																																																																																																																																																																																																																	
74LS12	25	74LS13	25																																																																																																																																																																																																																																																																																																																																																																																																																	
74LS14	25	74LS15	25																																																																																																																																																																																																																																																																																																																																																																																																																	
74LS16	25	74LS17	25																																																																																																																																																																																																																																																																																																																																																																																																																	
74LS18	25	74LS19	25																																																																																																																																																																																																																																																																																																																																																																																																																	
74LS20	25	74LS21	25																																																																																																																																																																																																																																																																																																																																																																																																																	
74LS22	25	74LS23	25																																																																																																																																																																																																																																																																																																																																																																																																																	
74LS24	25	74LS25	25																																																																																																																																																																																																																																																																																																																																																																																																																	
74LS26	25	74LS27	25																																																																																																																																																																																																																																																																																																																																																																																																																	
74LS28	25	74LS29	25																																																																																																																																																																																																																																																																																																																																																																																																																	
74LS30	25	74LS31	25																																																																																																																																																																																																																																																																																																																																																																																																																	
74LS32	25	74LS33	25																																																																																																																																																																																																																																																																																																																																																																																																																	
74LS34	25	74LS35	25																																																																																																																																																																																																																																																																																																																																																																																																																	
74LS36	25	74LS37	25																																																																																																																																																																																																																																																																																																																																																																																																																	
74LS38	25	74LS39	25																																																																																																																																																																																																																																																																																																																																																																																																																	
74LS40	25	74LS41	25																																																																																																																																																																																																																																																																																																																																																																																																																	
74LS42	25	74LS43	25																																																																																																																																																																																																																																																																																																																																																																																																																	
74LS44	25	74LS45	25																																																																																																																																																																																																																																																																																																																																																																																																																	
74LS46	25	74LS47	25																																																																																																																																																																																																																																																																																																																																																																																																																	
74LS48	25	74LS49	25																																																																																																																																																																																																																																																																																																																																																																																																																	
74LS50	25	74LS51	25																																																																																																																																																																																																																																																																																																																																																																																																																	
74LS52	25	74LS53	25																																																																																																																																																																																																																																																																																																																																																																																																																	
74LS54	25	74LS55	25																																																																																																																																																																																																																																																																																																																																																																																																																	
74LS56	25	74LS57	25																																																																																																																																																																																																																																																																																																																																																																																																																	
74LS58	25	74LS59	25																																																																																																																																																																																																																																																																																																																																																																																																																	
74LS60	25	74LS61	25																																																																																																																																																																																																																																																																																																																																																																																																																	
74LS62	25	74LS63	25																																																																																																																																																																																																																																																																																																																																																																																																																	
74LS64	25	74LS65	25																																																																																																																																																																																																																																																																																																																																																																																																																	
74LS66	25	74LS67	25																																																																																																																																																																																																																																																																																																																																																																																																																	
74LS68	25	74LS69	25																																																																																																																																																																																																																																																																																																																																																																																																																	
74LS70	25	74LS71	25																																																																																																																																																																																																																																																																																																																																																																																																																	
74LS72	25	74LS73	25																																																																																																																																																																																																																																																																																																																																																																																																																	
74LS74	25	74LS75	25																																																																																																																																																																																																																																																																																																																																																																																																																	
74LS76	25	74LS77	25																																																																																																																																																																																																																																																																																																																																																																																																																	
74LS78	25	74LS79	25																																																																																																																																																																																																																																																																																																																																																																																																																	
74LS80	25	74LS81	25																																																																																																																																																																																																																																																																																																																																																																																																																	
74LS82	25	74LS83	25																																																																																																																																																																																																																																																																																																																																																																																																																	
74LS84	25	74LS85	25																																																																																																																																																																																																																																																																																																																																																																																																																	
74LS86	25	74LS87	25																																																																																																																																																																																																																																																																																																																																																																																																																	
74LS88	25	74LS89	25																																																																																																																																																																																																																																																																																																																																																																																																																	
74LS90	25	74LS91	25																																																																																																																																																																																																																																																																																																																																																																																																																	
74LS92	25	74LS93	25																																																																																																																																																																																																																																																																																																																																																																																																																	
74LS94	25	74LS95	25																																																																																																																																																																																																																																																																																																																																																																																																																	
74LS96	25	74LS97	25																																																																																																																																																																																																																																																																																																																																																																																																																	
74LS98	25	74LS99	25																																																																																																																																																																																																																																																																																																																																																																																																																	
<table border="1"> <tr><td>74LS00</td><td>25</td><td>74LS01</td><td>25</td></tr> <tr><td>74LS02</td><td>25</td><td>74LS03</td><td>25</td></tr> <tr><td>74LS04</td><td>25</td><td>74LS05</td><td>25</td></tr> <tr><td>74LS06</td><td>25</td><td>74LS07</td><td>25</td></tr> <tr><td>74LS08</td><td>25</td><td>74LS09</td><td>25</td></tr> <tr><td>74LS10</td><td>25</td><td>74LS11</td><td>25</td></tr> <tr><td>74LS12</td><td>25</td><td>74LS13</td><td>25</td></tr> <tr><td>74LS14</td><td>25</td><td>74LS15</td><td>25</td></tr> <tr><td>74LS16</td><td>25</td><td>74LS17</td><td>25</td></tr> <tr><td>74LS18</td><td>25</td><td>74LS19</td><td>25</td></tr> <tr><td>74LS20</td><td>25</td><td>74LS21</td><td>25</td></tr> <tr><td>74LS22</td><td>25</td><td>74LS23</td><td>25</td></tr> <tr><td>74LS24</td><td>25</td><td>74LS25</td><td>25</td></tr> <tr><td>74LS26</td><td>25</td><td>74LS27</td><td>25</td></tr> <tr><td>74LS28</td><td>25</td><td>74LS29</td><td>25</td></tr> <tr><td>74LS30</td><td>25</td><td>74LS31</td><td>25</td></tr> <tr><td>74LS32</td><td>25</td><td>74LS33</td><td>25</td></tr> <tr><td>74LS34</td><td>25</td><td>74LS35</td><td>25</td></tr> <tr><td>74LS36</td><td>25</td><td>74LS37</td><td>25</td></tr> <tr><td>74LS38</td><td>25</td><td>74LS39</td><td>25</td></tr> <tr><td>74LS40</td><td>25</td><td>74LS41</td><td>25</td></tr> <tr><td>74LS42</td><td>25</td><td>74LS43</td><td>25</td></tr> <tr><td>74LS44</td><td>25</td><td>74LS45</td><td>25</td></tr> <tr><td>74LS46</td><td>25</td><td>74LS47</td><td>25</td></tr> <tr><td>74LS48</td><td>25</td><td>74LS49</td><td>25</td></tr> <tr><td>74LS50</td><td>25</td><td>74LS51</td><td>25</td></tr> <tr><td>74LS52</td><td>25</td><td>74LS53</td><td>25</td></tr> <tr><td>74LS54</td><td>25</td><td>74LS55</td><td>25</td></tr> <tr><td>74LS56</td><td>25</td><td>74LS57</td><td>25</td></tr> <tr><td>74LS58</td><td>25</td><td>74LS59</td><td>25</td></tr> <tr><td>74LS60</td><td>25</td><td>74LS61</td><td>25</td></tr> <tr><td>74LS62</td><td>25</td><td>74LS63</td><td>25</td></tr> <tr><td>74LS64</td><td>25</td><td>74LS65</td><td>25</td></tr> <tr><td>74LS66</td><td>25</td><td>74LS67</td><td>25</td></tr> <tr><td>74LS68</td><td>25</td><td>74LS69</td><td>25</td></tr> <tr><td>74LS70</td><td>25</td><td>74LS71</td><td>25</td></tr> <tr><td>74LS72</td><td>25</td><td>74LS73</td><td>25</td></tr> <tr><td>74LS74</td><td>25</td><td>74LS75</td><td>25</td></tr> <tr><td>74LS76</td><td>25</td><td>74LS77</td><td>25</td></tr> <tr><td>74LS78</td><td>25</td><td>74LS79</td><td>25</td></tr> <tr><td>74LS80</td><td>25</td><td>74LS81</td><td>25</td></tr> <tr><td>74LS82</td><td>25</td><td>74LS83</td><td>25</td></tr> <tr><td>74LS84</td><td>25</td><td>74LS85</td><td>25</td></tr> <tr><td>74LS86</td><td>25</td><td>74LS87</td><td>25</td></tr> <tr><td>74LS88</td><td>25</td><td>74LS89</td><td>25</td></tr> <tr><td>74LS90</td><td>25</td><td>74LS91</td><td>25</td></tr> <tr><td>74LS92</td><td>25</td><td>74LS93</td><td>25</td></tr> <tr><td>74LS94</td><td>25</td><td>74LS95</td><td>25</td></tr> <tr><td>74LS96</td><td>25</td><td>74LS97</td><td>25</td></tr> <tr><td>74LS98</td><td>25</td><td>74LS99</td><td>25</td></tr> </table>	74LS00	25	74LS01	25	74LS02	25	74LS03	25	74LS04	25	74LS05	25	74LS06	25	74LS07	25	74LS08	25	74LS09	25	74LS10	25	74LS11	25	74LS12	25	74LS13	25	74LS14	25	74LS15	25	74LS16	25	74LS17	25	74LS18	25	74LS19	25	74LS20	25	74LS21	25	74LS22	25	74LS23	25	74LS24	25	74LS25	25	74LS26	25	74LS27	25	74LS28	25	74LS29	25	74LS30	25	74LS31	25	74LS32	25	74LS33	25	74LS34	25	74LS35	25	74LS36	25	74LS37	25	74LS38	25	74LS39	25	74LS40	25	74LS41	25	74LS42	25	74LS43	25	74LS44	25	74LS45	25	74LS46	25	74LS47	25	74LS48	25	74LS49	25	74LS50	25	74LS51	25	74LS52	25	74LS53	25	74LS54	25	74LS55	25	74LS56	25	74LS57	25	74LS58	25	74LS59	25	74LS60	25	74LS61	25	74LS62	25	74LS63	25	74LS64	25	74LS65	25	74LS66	25	74LS67	25	74LS68	25	74LS69	25	74LS70	25	74LS71	25	74LS72	25	74LS73	25	74LS74	25	74LS75	25	74LS76	25	74LS77	25	74LS78	25	74LS79	25	74LS80	25	74LS81	25	74LS82	25	74LS83	25	74LS84	25	74LS85	25	74LS86	25	74LS87	25	74LS88	25	74LS89	25	74LS90	25	74LS91	25	74LS92	25	74LS93	25	74LS94	25	74LS95	25	74LS96	25	74LS97	25	74LS98	25	74LS99	25	<table border="1"> <tr><td>74LS00</td><td>25</td><td>74LS01</td><td>25</td></tr> <tr><td>74LS02</td><td>25</td><td>74LS03</td><td>25</td></tr> <tr><td>74LS04</td><td>25</td><td>74LS05</td><td>25</td></tr> <tr><td>74LS06</td><td>25</td><td>74LS07</td><td>25</td></tr> <tr><td>74LS08</td><td>25</td><td>74LS09</td><td>25</td></tr> <tr><td>74LS10</td><td>25</td><td>74LS11</td><td>25</td></tr> <tr><td>74LS12</td><td>25</td><td>74LS13</td><td>25</td></tr></table>	74LS00	25	74LS01	25	74LS02	25	74LS03	25	74LS04	25	74LS05	25	74LS06	25	74LS07	25	74LS08	25	74LS09	25	74LS10	25	74LS11	25	74LS12	25	74LS13	25																																																																																																																																																																															
74LS00	25	74LS01	25																																																																																																																																																																																																																																																																																																																																																																																																																	
74LS02	25	74LS03	25																																																																																																																																																																																																																																																																																																																																																																																																																	
74LS04	25	74LS05	25																																																																																																																																																																																																																																																																																																																																																																																																																	
74LS06	25	74LS07	25																																																																																																																																																																																																																																																																																																																																																																																																																	
74LS08	25	74LS09	25																																																																																																																																																																																																																																																																																																																																																																																																																	
74LS10	25	74LS11	25																																																																																																																																																																																																																																																																																																																																																																																																																	
74LS12	25	74LS13	25																																																																																																																																																																																																																																																																																																																																																																																																																	
74LS14	25	74LS15	25																																																																																																																																																																																																																																																																																																																																																																																																																	
74LS16	25	74LS17	25																																																																																																																																																																																																																																																																																																																																																																																																																	
74LS18	25	74LS19	25																																																																																																																																																																																																																																																																																																																																																																																																																	
74LS20	25	74LS21	25																																																																																																																																																																																																																																																																																																																																																																																																																	
74LS22	25	74LS23	25																																																																																																																																																																																																																																																																																																																																																																																																																	
74LS24	25	74LS25	25																																																																																																																																																																																																																																																																																																																																																																																																																	
74LS26	25	74LS27	25																																																																																																																																																																																																																																																																																																																																																																																																																	
74LS28	25	74LS29	25																																																																																																																																																																																																																																																																																																																																																																																																																	
74LS30	25	74LS31	25																																																																																																																																																																																																																																																																																																																																																																																																																	
74LS32	25	74LS33	25																																																																																																																																																																																																																																																																																																																																																																																																																	
74LS34	25	74LS35	25																																																																																																																																																																																																																																																																																																																																																																																																																	
74LS36	25	74LS37	25																																																																																																																																																																																																																																																																																																																																																																																																																	
74LS38	25	74LS39	25																																																																																																																																																																																																																																																																																																																																																																																																																	
74LS40	25	74LS41	25																																																																																																																																																																																																																																																																																																																																																																																																																	
74LS42	25	74LS43	25																																																																																																																																																																																																																																																																																																																																																																																																																	
74LS44	25	74LS45	25																																																																																																																																																																																																																																																																																																																																																																																																																	
74LS46	25	74LS47	25																																																																																																																																																																																																																																																																																																																																																																																																																	
74LS48	25	74LS49	25																																																																																																																																																																																																																																																																																																																																																																																																																	
74LS50	25	74LS51	25																																																																																																																																																																																																																																																																																																																																																																																																																	
74LS52	25	74LS53	25																																																																																																																																																																																																																																																																																																																																																																																																																	
74LS54	25	74LS55	25																																																																																																																																																																																																																																																																																																																																																																																																																	
74LS56	25	74LS57	25																																																																																																																																																																																																																																																																																																																																																																																																																	
74LS58	25	74LS59	25																																																																																																																																																																																																																																																																																																																																																																																																																	
74LS60	25	74LS61	25																																																																																																																																																																																																																																																																																																																																																																																																																	
74LS62	25	74LS63	25																																																																																																																																																																																																																																																																																																																																																																																																																	
74LS64	25	74LS65	25																																																																																																																																																																																																																																																																																																																																																																																																																	
74LS66	25	74LS67	25																																																																																																																																																																																																																																																																																																																																																																																																																	
74LS68	25	74LS69	25																																																																																																																																																																																																																																																																																																																																																																																																																	
74LS70	25	74LS71	25																																																																																																																																																																																																																																																																																																																																																																																																																	
74LS72	25	74LS73	25																																																																																																																																																																																																																																																																																																																																																																																																																	
74LS74	25	74LS75	25																																																																																																																																																																																																																																																																																																																																																																																																																	
74LS76	25	74LS77	25																																																																																																																																																																																																																																																																																																																																																																																																																	
74LS78	25	74LS79	25																																																																																																																																																																																																																																																																																																																																																																																																																	
74LS80	25	74LS81	25																																																																																																																																																																																																																																																																																																																																																																																																																	
74LS82	25	74LS83	25																																																																																																																																																																																																																																																																																																																																																																																																																	
74LS84	25	74LS85	25																																																																																																																																																																																																																																																																																																																																																																																																																	
74LS86	25	74LS87	25																																																																																																																																																																																																																																																																																																																																																																																																																	
74LS88	25	74LS89	25																																																																																																																																																																																																																																																																																																																																																																																																																	
74LS90	25	74LS91	25																																																																																																																																																																																																																																																																																																																																																																																																																	
74LS92	25	74LS93	25																																																																																																																																																																																																																																																																																																																																																																																																																	
74LS94	25	74LS95	25																																																																																																																																																																																																																																																																																																																																																																																																																	
74LS96	25	74LS97	25																																																																																																																																																																																																																																																																																																																																																																																																																	
74LS98	25	74LS99	25																																																																																																																																																																																																																																																																																																																																																																																																																	
74LS00	25	74LS01	25																																																																																																																																																																																																																																																																																																																																																																																																																	
74LS02	25	74LS03	25																																																																																																																																																																																																																																																																																																																																																																																																																	
74LS04	25	74LS05	25																																																																																																																																																																																																																																																																																																																																																																																																																	
74LS06	25	74LS07	25																																																																																																																																																																																																																																																																																																																																																																																																																	
74LS08	25	74LS09	25																																																																																																																																																																																																																																																																																																																																																																																																																	
74LS10	25	74LS11	25																																																																																																																																																																																																																																																																																																																																																																																																																	
74LS12	25	74LS13	25																																																																																																																																																																																																																																																																																																																																																																																																																	

# Turn Your Apple II into a Storage Oscilloscope

Capture "impossible" signals with an intelligent scope.

Larry Korba  
301 Fifth Ave.  
Ottawa, Ontario  
K1S 2N4 Canada

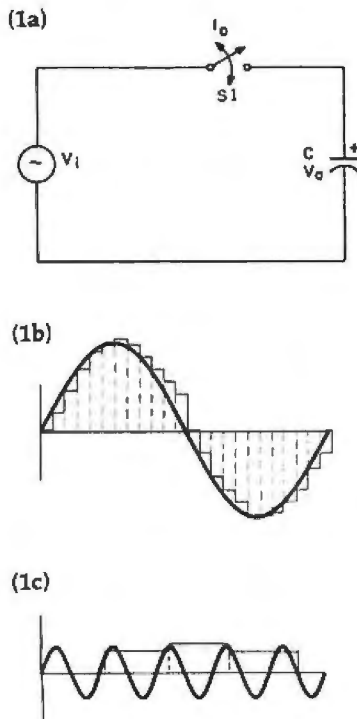

Figure 1: The sampling concept. Figure 1a shows a simple arrangement for sampling. Figures 1b and 1c compare the results of sampling at high and low rates. Sampling at a rate less than twice the frequency of the input signal (figure 1c) produces a type of error called aliasing.

With some simple additional hardware and software, an Apple II microcomputer can function as a storage-type oscilloscope ideally suited for transient, low-frequency signal display. An Apple II provides reasonably high-resolution graphics (160 by 280 pixels on high-resolution graphics page 1) and can be easily equipped with a Mountain Computer A/D + D/A board, an analog-to-digital and digital-to-analog converter.

If you have ever tried to display a transient, low-frequency signal on a standard oscilloscope, you know the meaning of frustration. Often (assuming you can even trigger on the signal of interest) it may recur only once every five seconds or so, far too infrequently for you to view the trace; or you may want to observe the events that occur just prior to the trigger event—a rather difficult task using a conventional oscilloscope.

## Sampling Theory

The application described here is a sampling system; that is, the input signal is sampled at regular intervals.

It is therefore prone to the pitfalls of such an approach. Figure 1 illustrates the concept of a sampling system. As switch  $S_1$  toggles on and off at a rate of  $f_s$ , the sampling frequency of the system, capacitor  $C$  stores the sample result between sampling times. As long as the sampling frequency is greater than *twice the highest frequency component of the input signal*, the output of the system is representative of the input (see figure 1b). For engineers in the crowd this might sound familiar; it is called the Nyquist criterion.

You may wonder what happens if there are frequency components in  $V_i$  greater than the sampling rate. This situation is illustrated in figure 1c, where a sinusoidal signal is sampled. The result is a signal resembling the input *waveshape*; however, the output frequency of the waveform is much less than the input signal. This effect is called *aliasing*. Just as a person would use an alias to disguise identity, so in a sampling system the input signal has its frequency disguised.

To minimize aliasing, an antialias-



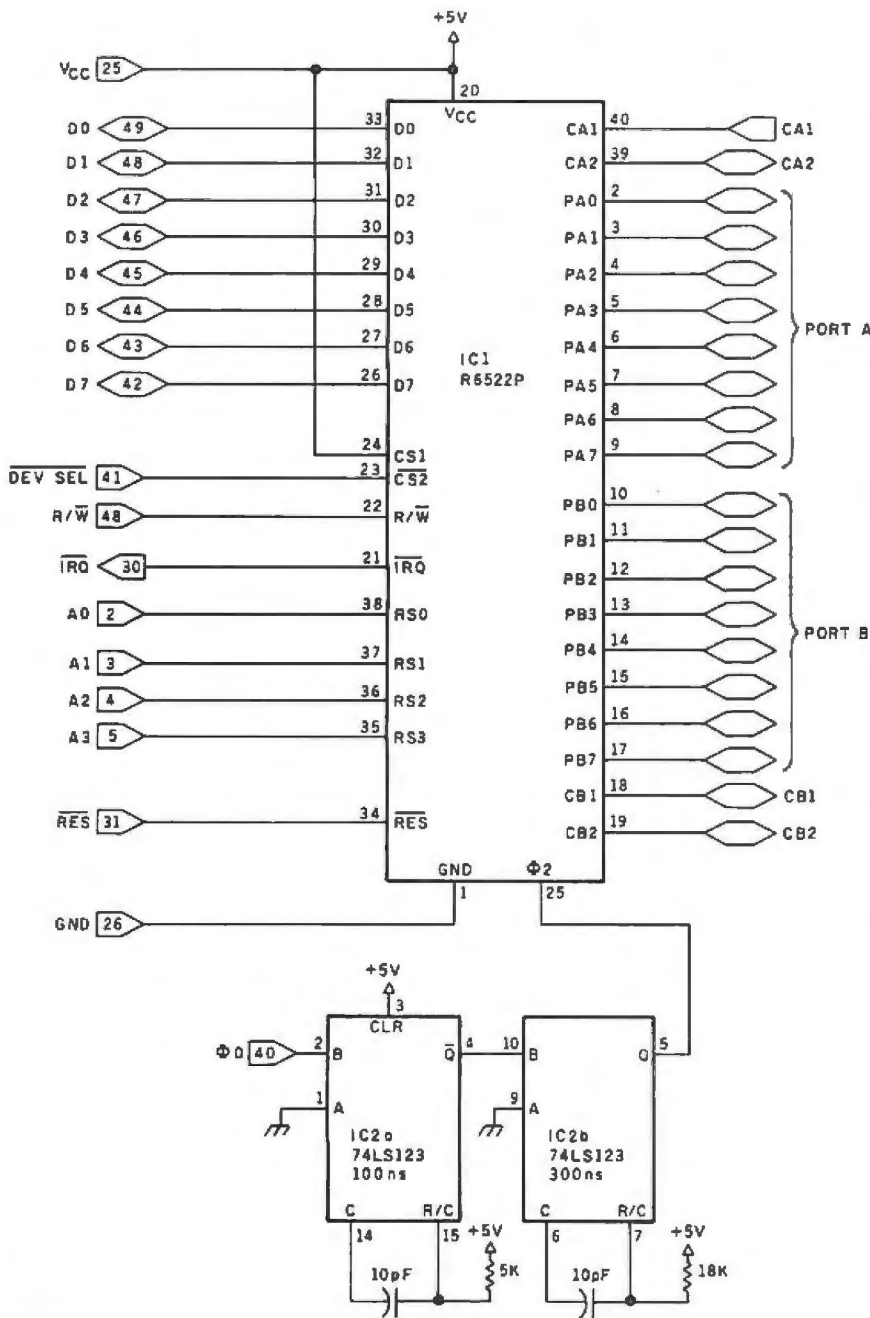

Number	Type	+5V	GND
IC1	6522	20	1
IC2	74LS123	16	8

Figure 2: Schematic diagram for connecting the 6522 versatile interface adapter to the Apple II's bus.

ing filter is usually inserted at the input to the switch to ensure that the frequency components of the input signal are restrained to the Nyquist rate. Antialiasing filters are simply low-pass filters that have very steep transitions from pass band to the cut-

off frequency in order to maximize the usable input frequency range.

An alternate approach is to use no antialiasing filter at all. The major requirement for this method is knowledge of the input signal. If it is known that the input signal is well behaved

and contains negligible components in the aliasing range, the sampling system will accurately represent the input signal. On the other hand, if the input signal is periodic, the aliasing effect can be used to advantage to display a signal that would normally require a much higher sampling rate. This effect is used in sampling oscilloscopes where very-high-frequency signals can be displayed by aliasing the signal down to within the bandwidth of the display electronics.

## Hardware

Besides the Apple II equipped with a Mountain Computer A/D + D/A board, this application uses a 6522 VIA (versatile interface adapter) timer. The timer is used to generate interrupts at regular (sampling) intervals. In figure 2, connection of the timer to the Apple II's bus is illustrated. The main problem to be solved is the proper synchronization of the 6522 clock and the Apple II's device-select pulses. This is achieved with two one-shot multivibrators.

The 6522 has 16 addressable registers to control 2 timers, 2 I/O (input/output) ports, and 4 control lines (see description of the 6522 VIA in Rockwell's *R6500 Hardware Manual*, pages 6-1 through 6-33). For this application, timer 1 is configured for continuous-interrupt mode. This interrupt is used to signal the moment an input sample must be taken.

The Mountain Computer board is used to perform an 8-bit analog-to-digital conversion of an input signal over an input-voltage range of -5 to +5 volts (V). The actual conversion requires about 10 microseconds ( $\mu$ s), so it is possible to measure 16 input signals (through a built-in input multiplexer) in less than 200  $\mu$ s. An input channel is read by accessing its address twice. The first reading starts the data conversion, the second reads the converted result.

## Software

Three programs are used for this application: Scope, Trace, and Adcode (see listing 1). Scope is an Apple-soft BASIC program that controls the overall operation of the oscilloscope. Adcode and Trace are 6502 assembly-

# Main/Frames

# Main/Frames

from  
**\$200**

- 30 Models of Enclosures
- Assembled and tested
- Quasi-Coax Motherboards
- Power Supply
- Card cage and guides
- Fan, line, cord, fuse, power & reset switches



8" Floppy Main/Frame



8" Disc Enclosure



Phase/80 8" Floppy Mainframe



Phase/80 Desk + Mainframe

Write or call for our brochure which includes our application note:  
"Building Computers — A Recipe"

## INTEGRAND

8620 Roosevelt Ave. • Visalia, CA 93291  
209/733-9288

We accept BankAmericard/Visa and MasterCard

Listing 1: The storage-oscilloscope programs for the Apple II. The Scope control program (listing 1a), written in Applesoft BASIC, accepts single-letter input commands to set up the interrupt-handling routine and display the signal with the proper scales. Listing 1b is an assembly-language program called Adcode, used to set up timer 1 of the 6522 versatile interface adapter to generate interrupts at regular intervals and to handle interrupts as they are generated. The assembly-language program Trace (listing 1c) is first used to scale the input data from the Adcode routine and then display it on high-resolution graphics page 1.

### Listing 1a

```

LOAD_SCOPE
LIST
7 OS = CHR$(4): REM CTRL-D
12 PRINT DS:"BLOAD AD.CODE.OBJ0": REM LOAD ASSEM PRGMS
13 PRINT DS:"BLOAD TRACE.OBJ0"
18 TIME = PRTR% = 0:LVL% = 1:MDS = "A"
19 REM GET SLOT NUMBER FOR THE A/D CARD
20 INPUT "SLOT NUMBER FOR A/D ":SLOT
30 IF SLOT < 1 THEN GOTO 20
40 IF SLOT > 5 THEN GOTO 20
50 GOSUB 255
90 PRINT "INPUT COMMAND"
100 GET AS
110 PRINT AS
120 IF AS = "H" THEN GOSUB 300: REM HELP
130 IF AS = "T" THEN GOSUB 400: REM SWEEP
140 IF AS = "S" THEN GOSUB 500: REM SETTINGS
150 IF AS = "P" THEN GOSUB 600: REM PRETRIG
160 IF AS = "L" THEN GOSUB 700: REM LEVEL
170 IF AS = "R" THEN GOSUB 800: REM RUN
175 IF AS = "M" THEN GOSUB 1500: REM MODE SET
180 IF AS = "C" THEN GOSUB 255: REM CHANNEL
195 IF AS = "E" THEN GOTO 200: END
190 GOTO 90: REM LOOP
200 END: REM SERVICE END COMMAND
255 INPUT "RECORDING CHANNEL ";CHAN%: REM SERVICE CHANNEL CMD
260 IF CHAN% > 15 THEN GOTO 255
270 IF CHAN% < 0 THEN GOTO 255
290 POKE 16393,SLOT * 16 + CHAN%: RETURN
300 TEXT: REM SERVICE HELP CMD
305 PRINT "H=HELP,T=SWEEP TIME,P=PRETRIGGER"
310 PRINT "L=LEVEL,S=SETTINGS,R=RECORD"
315 PRINT "M=MODE"
320 PRINT "T,P,L,M ARE FOLLOWED BY ARGUMENT REQUEST"
330 PRINT "ENTER 2.5 TO 1000 FOR T"
340 PRINT "0 TO 255 FOR P"
350 PRINT "S, C, OR A FOR M"
355 PRINT "1 TO 254 FOR L"
360 PRINT "FOLLOWED BY + OR - FOR SLOPE"
370 RETURN
400 INPUT "SWEEP TIME ";TIME: REM SERVICE TIME COMMAND
410 IF TIME < 2.5 THEN GOTO 400
420 IF TIME > 1000 THEN GOTO 400
430 TIME = TIME * 50
440 POKE 16395, INT ((TIME / 256 - INT (TIME / 256)) * 256 + .05) * 504 (TIME / 256)
450 POKE 16396, INT (TIME / 256)
460 RETURN
500 TEXT: REM SETTINGS DISPLAY
510 PRINT "SWEEP= ",(TIME / 50)
515 PRINT "PRETRIG= ",PRTR%
520 PRINT "TRIG LVL= ",LVL%,POL%
550 RETURN
600 INPUT "PRETRIGGER- ";PRTR%
610 IF PRTR% < 0 THEN GOTO 700
620 IF PRTR% > 255 THEN GOTO 700
640 POKE 16392,PRTR%: REM SAVE PRETRIGGER
650 RETURN
700 INPUT "TRIGGER LEVEL ";LVL%: REM SERVICE LEVEL CMD
710 IF LVL% < 1 THEN GOTO 700
720 IF LVL% > 254 THEN GOTO 700
725 POKE 16394,LVL%
730 INPUT "POLARITY( + / - ) = ";POL%
740 IF POL% = "+" THEN GOTO 770
750 IF POL% = "-" THEN GOTO 780
760 GOTO 730: REM OTHERWISE LOOP
770 POKE 16656,0: RETURN
780 POKE 16656,128: RETURN
800 HGR: REM SERVICE RUN CMD
802 HCOLOR=7: HPL0T 0,0: CALL 62454
805 IF TIME = 0 THEN GOTO 890
820 GOSUB 1700
830 GOSUB 1400
840 IF PEEK (16390) = 0 THEN GOTO 875
860 IF PEEK (- 16384) > 128 THEN GOTO 1000
870 GOTO 840
875 GOSUB 1100
880 IF MDS = "E" THEN RETURN
881 GOTO 850
890 PRINT "NO SWEEP SET": GOSUB 400: GOTO 800
1000 POKE 49374,64: REM TURN OFF INTERRUPT
1010 RETURN
1100 PRINT "DISPLAYING, SWEEP= ",TIME / 50: REM DISPLAY STORED DATA
1170 CALL 20480: REM SWEEP LINE
1290 IF PRTR% = 0 THEN GOTO 1320
1300 HCOLOR=1
1310 HPL0T PRTR%,0 TO PRTR%,159: REM DRAW PRETRIGGER
1320 LI = INT (159 - 9 * LVL% / 13): REM SCALE LEVEL
1330 HPL0T 1,LI TO 256,LI
1350 IF MDS = "S" THEN RETURN: REM CHECK FOR SINGLE STEP
1360 GOSUB 1400
1370 RETURN
1400 POKE 16655,0: REM RESET COUNTER
1405 CALL 16384: REM INIT INTERRUPT
1406 REM IF MODE=CONTINUOUS, DON'T WAIT FOR TRIGGER OR PRETRIGGER.
1407 IF MDS = "C" THEN GOSUB 1500
1410 PRINT "WAITING FOR TRIGGER"
    
```

Listing 1 continued:

```

1415 POKE 15190,128: REM SET READY
1420 RETURN
1500 INPUT "SINGLE S, CONTINUOUS C, AUTO A":MDS: RETURN
1500 POKE 15192,0: POKE 15191,128: REM SET PRETRIG=0 AND TRIG ON
1510 PRTR% = 0
1520 RETURN
1599 REM PUT IN HOR AND VERT AXIS
1700 HCOLOR= 0: FOR I = 0 TO 240 STEP 20
1710 HPLOT I,159 TO I,155
1720 NEXT I
1730 FOR I = 0 TO 159 STEP 15
1740 HPLOT 0,I TO 3,I: NEXT I
1750 HPLOT 0,80 TO 7,81: RETURN
    
```

Listing 1b

```

SOURCE FILE: ADCODE
0000: 1 * THIS IS AN INTERRUPT SERVICE PROGRAM TO
0000: 2 * BE USED WITH MOUNTAIN HARDWARE'S AD-DA BOARD
0000: 3 * INTERRUPTS ARE GENERATED BY A 5522 TIMER IN SLOT 5
0000: 4 *
0000: 5 * WHEN AN INTERRUPT OCCURS THE DESIRED AD
0000: 6 * CHANNEL IS READ AND STORED IN THE STORAGE AREA ARRAY.
0000: 7 * IF READY IS 0, NO READ OCCURS.
0000: 8 * IF READY THEN DATA IS CONTINUALLY STORED IN ARRAY
0000: 9 * IF THE INPUT DATA IS ABOVE THE TRIGGER LEVEL
0000: 10 * THEN THE AD DATA IS WRITTEN INTO ARRAY ONLY FOR
0000: 11 * THE NUMBER OF CHARACTERS INDICATED BY THE PRETRIGGER
0000: 12 * AMOUNT.
0000: 13 * ONCE ALL THE DATA IS COLLECTED, READY, TRIG AND AN INTERNAL
0000: 14 * SOFT COUNTER ARE ZEROED. THE TIMER1 INTERRUPT IS
0000: 15 * TURNED OFF TO ALLOW FAST USER THROUGHPUT
0000: 16 * "COUNT1" INDICATES THE START POINT OF DATA
0000: 17 * EQUATES
0000: 18 * INPUTS ARE:
0000: 19 * READY INDICATES READY TO START
0000: 20 * TRIG INDICATES TRIGGER LEVEL
0000: 21 * MAXCNT INDICATES PRETRIGGER LEVEL
0000: 22 * TICLA INDICATES TIMER1 INTERRUPT TIME
0000: 23 * TICHA HI BYTE OF TIMER 1
0000: 24 * POL INDICATES TRIGGER POLARITY
0000: 25 * CHNL CHANNEL OF A/D BOARD TO READ
0000: 26 *
0000: 27 * INPUTS ARE:
0000: 28 * READY INDICATES WHEN ALL DATA IS COLLECTED
0000: 29 * ARRAY2 STORES THE 256 DATA BYTES COLLECTED
0000: 30 *
03FF: 31 (ROAH EQU $03FF
03FE: 32 (ROAL EQU $03FE
00D4: 33 (ICL EQU $00D4
00D5: 34 (ICH EQU $00D5
00D8: 35 (ACH EQU $00D8
00DD: 36 (IFR EQU $00DD
00DE: 37 (IER EQU $00DE
00C0: 38 (INTSN EQU $00C0
0040: 39 (INTDIS EQU $0040
0000: 40 *
----- NEXT OBJECT FILE NAME IS ADCODE.D830
4000: 41 ORG $4000
4000:4C D0 41 42 START JMP INIT
4003:4C E9 41 43 JMP INIT2 ENTRY POINT NOT USED
4006: 44 *
4006: 45 * USER ALTERABLE BUFFERS
4006: 46 *
4006: 47 READY DS 1 15190 READY INDICATOR
4007: 48 * 0-NOT READY,128- READY
4007: 49 TRIG DS 1 15191 TRIGGERED INDICATOR
4008: 50 * 0- NOT TRIGGERED,128, TRIGGERED
4008: 51 MAXCNT DS 1 16392 PRETRIGGER AMOUNT
4009: 52 CHNL DS 1 16391 SLOT*16+CHANNEL
400A: 53 TRIGL DS 1 16394 TRIGGER LEVEL 0-255
400B: 54 TICLA DS 1 16395 TIMER VALUE
400C: 55 TICHA DS 1 16396 TIMER VALUE HI
400D: 56 *
400D: 57 ARRAY2 DS 256 16397
410D: 58 *
410D:00 59 SAMPLE DFB $00 TEMP SAVE AREA FOR SAMPLE
410E:00 60 COUNT DFB $00 COUNT TO END OF SAMPLE
410F:00 61 COUNT1 DFB $00 16655 CYCLING LOOPCOUNTER
4110:00 62 POL DFB $00 16656 TRIG POLARITY
4111: 63 * 0 = +VE POL,580 = -VE TRIG
4111:00 64 IND1 DFB $00 16657 INDICATES READY FOR TRIG
4112:00 65 IND2 DFB $00 INTERNAL READY INDICATOR
4113:00 66 MAXCNT1 OPB $00 INVERTED MAX COUNT
4114: 67 *
4114: 68 * INTERRUPT SERVICE
4114: 69 *
4114:8A 70 (INTSRV FXA GET X AND Y
4115:48 71 PHA AND SAVE ON STACK
4116:98 72 FYA ACC SAVED IN ADDR $45
4117:48 73 PHA
4118:AD DD C0 74 LDA IFR GET FLAG
4118:10 03 75 BPL INTW RETURN IF NOT TIMER1 INTERRUPT
411D:0A 76 ASL A
411E:10 03 77 BMI INTX IF TIM1 CONT
4120:4C C9 41 78 INTW JMP RT11 OTHERWISE RETURN
4123:AD D4 C0 79 INTX LDA TICL RESET TIMER FLAG
4125: 80 * GET SAMPLE
4126:AE 09 40 81 LDX CHNL GET CHANNEL
4129:BD 80 C0 82 LDA SC090,X GET SAMPLE
412C:EA 83 NOP
412D:EA 84 NOP
412E:EA 85 NOP WAIT FOR CONVERSION TO FINISH
412F:EA 86 NOP
4130:EA 87 * JP
4131:8D 80 C0 88 LDA SC080,X GET DATA
4134:8D 0D 41 89 STA SAMPLE SAVE FOR LATER
4137: 90 *
4137: 91 * SEE IF READY FOR DATA COLLECTION
4137:AD 06 40 92 LDA READY
413A:DD 03 93 BNE INTY CONT IF READY
    
```

Listing 1 continued on page 524

# SUPERBRAIN II

**PRICE  
BREAKTHROUGH**

Intertec Data Systems' new SuperBrain II has all the features of the former SuperBrain, plus:

- Impressive Graphics capability
- Below-the-line descenders and reverse video
- Faster, enhanced disk operating system
- Battery operated real-time clock
- Microsoft Basic at no extra charge

**NEW** SUPERBRAIN II Jr. . . . \$1,895  
350K Disk—64K RAM

**NEW** SUPERBRAIN II QD. . . \$2,275  
700K Disk—64K RAM

**NEW** SUPERBRAIN II SD . . . \$2,655  
1.5 MB Disk—64K RAM

**10 MB HARD DISK . . . \$2,995**  
(Includes Interface Cable)

**NEW** STARGRAPH. \$3,890 **List Cost** \$ Call  
Includes 350K Disk—64K RAM.

Emulates Tektronix™ 4010  
Graphics Terminal,  
Supports SAS-Graph and all  
Tektronix Plot 10 Software

**All Micro Pro™ Software**  
**50% Off List**

**List Cost**  
WordStar . . . . \$ 495 \$ 257  
MailMerge . . . . \$ 150 \$ 78  
CalcStar . . . . \$ 295 \$ 153

**Call for Similar Discounts on  
Other Micro Lines & Printers**

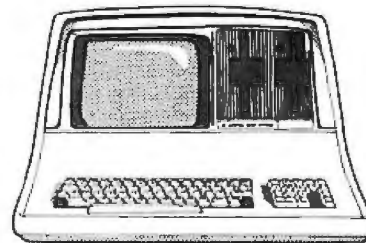

**90 Day Money Back Guarantee\***  
**120 Day Extended Warranty\*\***

Ordering Information: Money Orders, Cashier Checks or Bank Wires Welcome. Personal or Company Checks, allow 15 days to clear. Surface Freight Standard F.O.B. Origin. Include your telephone number. No COD's, please. Prices are subject to change without notice. Order desk hours are 9 to 5 CST.

**CALL OR WRITE**  
**(214) 931-9069**

**WESTSTAR MICRO**

16990 Dallas Parkway • Suite 151  
Dallas, Texas 75248

SuperBrain is a Registered Trademark of Intertec Data Systems. \*No form or Program. \*\*Extended Warranty. Terms by WestStar. Telephone is a Registered Trademark of WestStar.

# CHOOSE...

## An Apple Desk



A compact Bi-Level desk ideal for the Apple computer system. This 42" x 29½" desk comes with a shelf to hold two Apple disk drives. The top shelf for your TV or monitor and manuals can also have an optional paper slot to accommodate a printer. It is shown here with the optional Corvis shelf which will hold one Corvis disk drive. The Corvis shelf is available on the 52" x 29½" version of the Apple desk.

## A Universal Micro Desk



The Universal Micro desk accommodates the S-100 type microcomputers. The desk is available in four sizes: 17.75 inch, 19.06 inch, and 20.75 inch wide openings with 24 inch front-to-rear mounting space. The fourth size is a 20.75 inch wide opening with a 26.50 inch front-to-rear mounting space.

## A Mini Rack



Mini racks and mini micro racks have standard venting, cable cut outs and adjustable RETMA rails. Choose a stand alone bay or a 48", 60", or 72" desk model in a variety of colors and wood tones. A custom rack is available for the Cromemco.

## A Printer Stand



The Universal printer stand fits the:

- |                    |                        |
|--------------------|------------------------|
| Centronics 700's   | Diablo 1600's & 2300's |
| Dec LA 34          | T.I. 810 & 820         |
| NEC Spinwriter     | Okidata Slimline       |
| Lear Siegler 300's | Anadex 9500's          |

Delivery in days on most styles in stock. Dealers inquiries invited.

### ELECTRONIC SYSTEMS FURNITURE COMPANY

17129 S. Kingsview Avenue  
Carson, California 90746  
Telephone: (213)538-9601

### Listing 1 continued:

413C:4C C9 41	94	JMP	RTI1	OTHERWISE EXIT
411F:	95 *			
413F:	96	* CHECK	IF INTERNALLY READY	
413F:AD 12 41	97	INTY	LDA	IND2
4142:FD 6E	98	BEG	INT02	JUST STORE MORE IF NOT
4144:	99	* CHECK	IF SIGNAL TRIGEMRED	
4144:AD 07 40	100	LDA	TRIG	
4147:DD 45	101	SNE	INT01	STORE DATA IF TRIG
4149:	102	* SEE	IF READY FOR TRIG	
4149:AD 11 41	103	LDA	IND1	
414C:FD 30	104	BMI	INT0C	JUMP IF READY
414E:AD 10 41	105	LDA	POL	CHECK POLARITY
4151:FD 10	106	BEO	INT0B	JUMP IF +VE
4153:AD 0D 4L	107	LDA	SAMPLE	CHECK FOR INPT > TRIG
4156:CD 0A 40	108	CMP	FRVLV	
4159:90 57	109	BCC	INT02	
415B:A9 90	110	INT0A	LDA	ISS0
415D:8D 11 41	111	STA	IND1	SET UP INDICATOR
4160:4C B2 41	112	JMP	INT02	
4163:AD 0D 41	113	INT0B	LDA	SAMPLE
4166:CD 0A 40	114	CMP	FRVLV	
4169:90 FD	115	BCC	INT0A	CHECK FOR INPT<TRIG
416B:4C B2 41	116	JMP	INT02	OTHERWISE CONTINUE
416E:	117	* CHECK	TRIGGER LEVEL	
416E:AD 10 41	118	INT0C	LDA	POL
4171:10 08	119	BPL	INT0D	JMP IF +VE
4173:AD 0D 41	120	LDA	SAMPLE	
4176:CD 0A 40	121	CMP	FRVLV	CHECK FOR -VE TRIG
4179:90 08	122	BCC	INT0E	JUMP IF TRIG
417B:4C B2 41	123	JMP	INT02	
417E:AD 0D 41	124	INT0D	LDA	SAMPLE
4181:CD 0A 40	125	CMP	FRVLV	
4184:90 3C	126	BCC	INT02	JUMP IF NOT TRIG
4186:A9 80	127	INT0E	LDA	ISS0
4188:8D 07 40	128	STA	TRIG	INDICATE TRIGGERED
418B:4C B2 41	129	JMP	INT02	
418E:AD 0E 41	130	INT01	LDA	COUNT
4191:CD 13 41	131	CMP	MAXCN1	
4194:90 19	132	BCC	INT01A	JUMP IF PRETRIG DONE
4196:A9 00	133	LDA	000	
4199:8D 07 40	134	STA	TRIG	ZERO BUFFERS
419B:9D 06 40	135	STA	READY	
419E:8D 0E 41	136	STA	COUNT	
41A1:8D 11 41	137	STA	IND1	
41A4:9D 12 41	138	STA	IND2	
41A7:A9 40	139	LDA	INTDIS	
41A9:9D 0E C0	140	STA	IER	DISABLE INTERRUPTS
41AC:4C C9 41	141	JMP	RTI1	
41AF:EE 0E 41	142	INT01A	INC	COUNT
41B2:AD 0F 41	143	INT02	LDA	COUNT1
41B5:A8	144	PAY		
41B6:CD 08 40	145	CMP	MAXCN1	
41B9:90 05	146	BCC	INT03	JUMP IF NOT ENOUGH
41BB:A9 80	147	LDA	ISS0	
41BD:8D 12 41	148	STA	IND2	SET SET UP INDICATOR
41C0:AD 00 41	149	INT03	LDA	SAMPLE
41C3:99 0D 40	150	STA	ARRAY2,Y	GET SAMPLE
41C6:EE 0F 41	151	INC	COUNT1	SAVE DATA IN ARRAY
41C9:68	152	RTI1	PLA	INC STORE POINTER
41CA:A8	153	PAY		RESTORE REGISTERS
41CB:68	154	PLA		
41CC:AA	155	PAX		
41CD:A5 45	156	LDA	S45	RESTORE ACC
41CF:40	157	RTI		
41D0:	158 *			
41D0:78	159	INIT	SEI	
41D1:A9 41	160	LDA	INTSRV	
41D3:8D FF 03	161	STA	IRQA	SET UP INTERRUPT VECTOR
41D6:A9 14	162	LDA	INTSRV	
41D8:8D FE 03	163	STA	IRQA	
41DB:A9 90	164	LDA	000	SET UP USER BUFFERS
41DD:8D 06 40	165	STA	READY	
41E0:8D 0F 41	166	STA	COUNT1	
41E3:8D 0E 41	167	STA	COUNT	
41E6:8D 07 40	168	STA	TRIG	
41E9:A9 00	169	INIT2	LDA	000
41EB:18	170	CLC		
41EC:ED 08 40	171	SBC	MAXCN1	
41EF:8D 13 41	172	STA	MAXCN1	SAVE INVERTED PRETRIG
41F2:	173 *			
41F2:A9 C0	174	LDA	ISS0	SET UP ACR
41F4:8D D8 C0	175	STA	ACR	
41F7:AD 08 40	176	LDA	TICLA	SET UP TIMER 1
41FA:9D 04 C0	177	STA	TICL	
41FD:AD 0C 40	178	LDA	TICHA	
4200:9D 05 C0	179	STA	TICH	
4203:A9 C0	180	LDA	INTPEN	ENABLE INTERRUPTS
4205:8D DE C0	181	STA	IER	
4208:D8	182	CLD		
4209:58	183	CLI		
420A:60	184	RTS		

\*\*\* SUCCESSFUL ASSEMBLY: NO ERRORS

C008 ACR	400D ARRAY2	4009 CHNL	410E COUNT
410F COUNT1	CODE IER	C0DD IFR	4111 IND1
4112 IND2	41E9 INIT2	4100 INIT	418E INT01
41AF INT01A	4182 INT02	41CD INT03	415B INT0A
4153 INT0B	414E INT0C	417E INT0E	4186 INT0E
40 INTDIS	C0 INTEN	4114 INTSRV	4120 INTW
4123 INTX	413F INTY	D3FF IRQAR	D3FE IRQAL
4113 MAXCN1	4008 MAXCN1	4110 PDL	4006 READY
41C9 RTI1	410D SAMPLE	74000 START	C0D5 TICH
400C TICHA	C0D4 TICL	400B TICLA	4007 TRIG
400A TRVLV			

Listing 1 continued:

74000 START	40 INTDIS	CO INTEN	03FB IRDAL	03FF INQAH
4029 CHNL	4005 READY	4007 TRIG	4008 MAXCNT	
4000 ARRAY2	400A TRVLV	400B TICLA	400C TICHA	
4113 PDL	4100 SAMPLE	410E COUNT	410F COUNT1	
4114 INFSRV	4111 INDI	4112 IND2	4113 MAXCN1	
4158 INFDA	4120 INTN	4121 INTY	413F INTY	
4135 INPDE	4151 INTOR	415E INTOC	417E INFOO	
41C0 INTOT	418E INTOI	41AF INTOIA	41A2 INFO2	
COO4 TICL	41C9 RTIL	41D0 INIT	41E9 INIF2	
CODE IER	COO5 TICN	COO9 ACR	COOD IPR	

Listing 1c

```

0000:      1          LST ON
0000:      2 * THIS PROGRAM USES THE APPLESOFT HIGH
0000:      3 * RESOLUTION GRAPHIC SUBROUTINES TO DISPLAY
0000:      4 * THE OUTPUT OF THE RECORDING STAGE OF THE SCOPE PROGRAM
0000:      5 * THE INPUTS TO THIS PROGRAM ARE:
0000:      6 *
0000:      7 * 1. ARRAY2-THE ARRAY IN WHICH THE V/D DATA IS STORED
0000:      8 * BY THE INTERRUPT SERVICE ROUTINE
0000:      9 * 2. COUNT1-THE OFFSET INTO ARRAY2 POINTING TO THE
0000:     10 * FIRST BYTE OF THE LAST RECORDING
0000:     11 * THE OUTPUTS ARE:
0000:     12 * 1. ARRAY2-THE 255 VALUES OF ARRAY2 ARE SCALED TO FIT THE 160 HIGH
0000:     13 * HCR SCREEN 1.
0000:     14 * 2. ARRAY1-A SORTED ARRAY OF ARRAY2 VALUES SORTED
0000:     15 * FOR VERTICAL DISPLAY ON THE 290X160 HI RES SCREEN 1
0000:     16 * 3. A DISPLAY OF THE RECORDED DATA ON THE APPLE SCREEN
0000:     17 * GENERAL EQUATES
0000:     18 *
0000:     19 * HI RESOLUTION GRAPHIC ROUTINES
0000:     20 *
0000:     21 HLLN EQU $F53A LINE WRITES
0000:     22 HPL0T EQU $F457 POSITION DOT
0000:     23 SETMCOE EQU $E4 COLOUR BYTE LOCATION
0000:     24 *
0000:     25 * EQUATES FOR BUFFERS IN ADTODE
0000:     26 *
0000:     27 ARRAY2 EQU $400D
0000:     28 COUNT1 EQU $410F
0000:     29 *
0000:     30 *
0000:     31 * START OF PROGRAM
0000:     32 *
----- NEXT OBJECT FILE NAME IS TRACE.OBJO
5097:      33          ORG $5000
5000:4C 07 51 34          JMP START
5003:      35 * USER BUFFERS
5003:00      36 CTR DFB $00 X COORD COUNTER
5004:00      37 CTR1 DFB $00 INPUT DATA INDEX
5005:FF      38 ARRAY1 DFB $FF SAVE AREA FOR OLD DATA
5006:      39          DS 255
5105:00      40 OUTL1 DFB $00 DIV OUTPUT
5106:00      41 OUTA DFB $00 INPUT TO DIVIDE
5107:AD 0F 41 42 START LDA COUNT1 GET DATA INDEX
510A:8D 04 53 43          STA CTR1 SAVE FOR INDEXING DATA
510D:AD 05 59 44          LDA ARRAY1
5110:C9 FF      45 CMP #FFF CHECK FOR FIRST TIME THRU
5112:FD 22      46 SEQ CLR IF BYTE =FF,CLEAR
5114:A9 20      47 ST1 LDA #0
5116:8D 03 50 48          STA CTR ZERO COUNTER
5119:20 8D 51 49          JSR CALC ADJUST INPUT DATA
511C:20 43 51 50 LOOP JSR ERASE ERASE OLD LINE
511F:20 60 51 51          JSR DRAW DRAW NEW LINE SEG
5122:AD 03 50 52          LDA CTR GET OUTPUT PTR
5125:C9 FF      53 CMP #255 IF NOT POINTING TO LAST BYTE
5127:9D F3      54 BCC LOOP LOOP
5129:A8 04 50 55 RTSI LDX CTR1 INCR POINT
512C:AC 03 50 56          LDY CTR GET OLD DATA POINTER
512F:8D 0D 40 57          LDA ARRAY2,X
5132:99 05 50 58          STA ARRAY1,Y
5135:50          59 RTS
5136:      60 * CLEAR ARRAY
5136:A2 FF      61 CLR LDX #FFF SET UP LOOP COUNT
5138:A9 00      62 LDA #0
513A:9D 05 50 63 CLRLP STA ARRAY1,X ZERO ARRAY
513D:CA          64 DEX POINT TO NEXT LOCATION
513E:DD FA          65 BNE CLRLP
5140:4C 14 51 66          JMP ST1 RETURN TO MAIN LINE
5143:      67 * ERASE OLD LINE
5143:A9 7F      68 ERASE LDA #127 SET WHITE
5145:85 E4          69 STA SETMCOE
5147:AE 03 50 70          LDX CTR
514A:A0 00      71 LDY #00 ZERO Y REG
514C:8D 05 50 72          LDA ARRAY1,X GET DATA
514F:20 57 F4 73          JSR HPL0T
5152:AE 03 50 74          LDX CTR
5155:E8          75 INX POINT TO NEXT DATA POINT
5156:8C 05 50 76          LDY ARRAY1,X GET DATA
5159:8A          77 TXA
515A:A2 00      78 LDX #00 ZERO X REG
515C:20 3A F5 79          JSR HLLN DRAW LINE RTS
515F:60          80 RTS
5160:      81 * DRAW NEW LINE
5160:A9 00      82 DRAW LDA #0 SET BLACK
5162:95 E4          83 STA SETMCOE
5164:AE 04 50 84          LDX CTR1
5167:AC 03 50 85          LDY CTR READY TO SAVE NEW AS OLD
516A:9D 0D 40 86          LDA ARRAY2,X GET NEW DATA
516D:99 05 50 87          STA ARRAY1,Y STORE AS OLD
5170:A0 00      88 LDY #00
5172:A8 03 50 89          LDX CTR GET CURRENT POS
5175:20 57 F4 90          JSR HPL0T
5178:EE 04 50 91          INC CTR1 POINT TO NEXT INPUT BYTE
517B:AE 04 50 92          LDX CTR1 POINT TO NEXT BYTE
517E:8C 0D 40 93          LDY ARRAY2,X GET NEXT DATA
5181:EE 03 50 94          INC CTR POINT TO NEXT POSITION
5184:AD 03 50 95          LDA CTR GET X COORD
5187:A2 00      96 LDX #00
5189:20 3A F5 97          JSR HLLN
518C:60          98 RTS
518D:      99 * CALCULATE 159-3*(INPUT DATA)/11

```

# Call for MTI's late price reductions.

Ask about our "QED" discounts.  
VISA and MasterCard orders accepted.

## VIDEO TERMINALS

	MTI Price
VT 100 DECscope .....	\$ 1595
VT 18X Personal Computing Option .....	2395
VT 101 DECscope .....	1195
VT 131 DECscope .....	1745
VT 132 DECscope .....	1995
ADM 3A (dumb terminal) .....	595
ADM 5 (dumb with visual attributes) .....	645
ADM 31 (two page buffer) .....	1095
ADM 21 (full editing/visual attributes) .....	690
ADM 32 (ergonomic ADM 31) .....	.
ADM 36 (DEC system terminal) .....	.
ADM 42 (8-page buffer available) .....	.
TI 940 (high performance, 1-page buffer) .....	1650
Hazeltine Esprit .....	575
Hazeltine Executive 80 Model 20 .....	1345
Hazeltine Executive 80 Model 30 .....	1695
Hazeltine 1500 (dumb terminal) .....	825

## GRAPHICS TERMINALS

VT 125 (DEC ReGIS firmware) .....	3280
VT 100 (Tektronix 4010 emulation) .....	3250
ADM 3A (Tektronix 4010 emulation) .....	1795
ADM 5 (tektronix 4010 emulation) .....	1845
VT 100 w/TI 810 plot, (Tektronix emul) .....	5920

## 300 BAUD TELEPRINTERS

LA 34-AA DECwriter IV .....	1095
Diablo 630 RO (letter quality) .....	2295
Diablo 630 KSR (letter quality) .....	2695
TI 743 (portable thermal printer) .....	1190
TI 745 (port./built-in coupler) .....	1485
TI 765 (port./bubble/b-i coupler) .....	2595

## 600 BAUD TELEPRINTERS

Epson MX-80 .....	645
TI 825 KSR impact .....	1570
TI 825 KSR pkg. .....	1795

## 1200 BAUD TELEPRINTERS

Epson MX-100 .....	895
LA 120 RA (receive only) .....	2095
LA 120 AA DECwriter III .....	2295
LA 100 RO letter printer .....	1937
LA 12-A (port./modem/coupler) .....	2840
TI 785 (portable thermal printer) .....	1645
TI 787 (port./internal modem) .....	2270
TI 810 RO impact .....	1545
TI 810 RO pkg. .....	1795
TI 820 RO impact .....	1850
TI 820 RO pkg. .....	2025
TI 820 KSR impact .....	2025
TI 820 KSR pkg. .....	2195
Leary Siegler 310 ballstic .....	1945

## 2400 BAUD

Dataproducts M 200 (2400 baud) .....	2910
--------------------------------------	------

## DATAPRODUCTS LINE PRINTERS

B 300 (300 lpm Band Printer) .....	5455
B 600 (600 lpm Band Printer) .....	6930
B 1000 (1000 lpm Band Printer) .....	11330
BP 1500 (1500 lpm Band Printer) .....	18700

(Controllers available for most minis & micros)

## ACOUSTIC COUPLERS

A/J A242-A (300 baud orig.) .....	242
A/J 247 (300 baud orig.) .....	315
Vadic VA 3413 (300/1200 orig.) .....	845

## MODEMS

GDC 103A3 (300 baud Bell) .....	395
GDC 2025/T (1200 baud Bell) .....	585
VA 3213 (Bell 212-A comp.) .....	825
VA 3451 (orig./ans. triple modem) .....	885
VA 3455 (1200 baud orig./ans.) .....	770
VA 2450 (Bell 201 comp.) .....	725
VA 103 (300 baud modem/phone) .....	235

\*Please call for quotation.



Applications Specialists & Distributors  
Computer Terminals, Peripherals & Systems

New York:  
516/621-6200, 212/767-0677, 518/449-5959  
Outside N.Y.S.: 800/645-6530  
New Jersey: 201/227-5552  
Ohio: 216/464-6688

```

518D:      100 * SCALING FOR THE DISPLAY
519D:      101 CALC      EQJ *
51BD:AE 04 50 102      LDX      CTR1      POINT TO START OF INPUT DATA
519D:A0 00 103      LDY      #000      LOOP 256 TIMES
5192:BD 00 40 104 LOOP1  LDA      ARRAY2,X  GET DATA
5195:BD 05 51 105      STA      OUTA      SET UP FOR CALC
5198:20 C9 51 106      JSR      DIV13     DIV BY 13
519B:20 B9 51 107      JSR      MULT8      MULT RESULT BY 9
519E:20 E3 51 108      JSR      DIV1      GET REMAINDER
51A1:AD 06 51 109      LDA      OUTA
51A4:C9 07 110      CMP      #07
51A6:90 03 111      BCC      CALC1
51A8:EE 05 51 112      INC      OUTL1     INCR OUTPUT
51AB:3B 113 CALC1  SEC
51AC:A9 9F 114      LDA      #159     SUBTRACT RESULT FROM 159
51AE:ED 05 51 115      SBC      OUTL1
51B1:9D 00 40 116      STA      ARRAY2,X
51B4:E9 117      INX
51B5:8B 118      DEY
51B6:D0 DA 119      BNE      LOOP1     LOOP 255 TIMES
51B8:60 120      RTS
51B9:98 121 MULT8  TYA
51BA:48 122      PHA          SAVE Y ON STACK
51BB:A0 03 123      LDY      #03      SET UP LOOP COUNT
51BD:0E 05 51 124 MULTL  ASL      OUTL1     MULT BY 2
51C0:0E 06 51 125      ASL      OUTA      MULT BY 2
51C3:88 126      DEY
51C4:D0 F7 127      BNE      MULTL
51C6:68 128      PLA
51C7:A8 129      TAY
51C8:60 130      RTS
51C9:      131 * DIVIDE BY 13
51C9:A9 00 132 DIV13 LDA      #00      ZERO RESULT
51CB:BD 05 51 133      STA      OUTL1
51CE:AD 05 51 134      LDA      OUTA      GET DIVIDEND
51D1:C9 82 135      CMP      #130     COMPARE AGAINST 10*13
51D3:90 0E 136      BCC      DIV1      JUMP IF <130
51D5:AD 06 51 137      LDA      OUTA
51D8:38 138      SEC
51D9:E9 82 139      SBC      #130     SUBTRACT 130 FROM INPT
51DB:9D 05 51 140      STA      OUTA
51DE:A9 7A 141      LDA      #10
51E0:BD 05 51 142      STA      OUTL1     SAVE PART OF RESULT
51E3:98 143 DIV1  TYA
51E4:48 144      PHA
51E5:A0 00 145      LDY      #00
51E7:38 146 DIV2  SEC
51E8:AD 06 51 147      LDA      OUTA      GET INPUT
51EB:C9 0D 148      CMP      #13      CHECK IF DIVIDEND TOO SMALL
51ED:90 08 149      BCC      DIV3      EXIT IF DIV<13
51EF:E9 0D 150      SBC      #13
51F1:BD 06 51 151      STA      OUTA
51F4:C8 152      INY
51F5:10 F0 153      BPL      DIV2      ALWAYS JUMP
51F7:98 154 DIV3  TYA
51F8:18 155      CLC
51F9:6D 05 51 156      ADC      OUTL1     ADD LOOP COUNT TO RESULT
51FC:BD 05 51 157      STA      OUTL1     SAVE RESULT
51FF:68 158      PLA
5200:A8 159      TAY
5201:60 160      RTS
5202:      161      LST      ON

*** SUCCESSFUL ASSEMBLY: NO ERRORS

5005 ARRAY1      400D ARRAY2      51A8 CALC1      519D CALC
5136 CLR        513A CLRRLP      410F COUNT1     5003 CTR
5004 CTR1       51E3 DIV1      51C9 DIV13      51E7 DIV2
51F7 DIV3      51E0 DRAW      5143 ERASE      F53A HLM
F457 HPLQF     5192 LOOP1     511C LOOP       51A9 MULT8
518D MULTL     5106 OUTA      5105 OUTL1      25129 RPS1
84 SETHCOL    5114 ST1      5107 START
    
```

language routines for interrupt handling and graphics display functions, respectively.

The Adcode program has two entry points. You call the routine commencing at the label Start to initialize buffers used by the interrupt subroutine and set up the interrupt vector and all registers controlling the operation of timer 1. The label Intserv indicates the start of the interrupt-service routine. This is the point to which program control eventually passes when an interrupt occurs. A flowchart for this program is shown in figure 3; key labels are indicated.

The overall purpose of Adcode is

to read converted analog data and store it in a 256-byte array (Array2). Start of the data-record period is indicated by the Ready indicator byte. Once this byte is set to hexadecimal 80, the interrupt routine will store converted data in Array2 on future interrupts until the input signal satisfies the trigger requirements. When the trigger occurs, more data is stored in the array to allow display of the data following the trigger. This is done by collecting a number of data points equal to 256 minus the pretrigger count.

This interrupt-service routine allows a maximum sampling rate of

approximately 8 kilohertz (kHz), which leaves about 50 percent of the processor time for execution of the Scope program.

Scope is an Applesoft BASIC program that provides a method for altering the controls of the display. It provides for input of certain functions by way of single-letter commands:

**T:** (sweep-time setting) indicates the number of milliseconds (ms) per horizontal display division; ranges from 2.5 to 1000 ms/division.

**P:** (pretrigger amount) a number between 0 and 255 that indicates the number of samples to be displayed before the trigger event occurs.

**L:** (level and slope) a number between 1 and 254 that indicates the level and slope at which the trigger occurs (the slope is either + or -, to indicate which way the input signal should pass through the level to indicate a trigger).

**S:** (settings) a display of the present sweep time, pretrigger amount, trigger level, and polarity.

**H:** (help) provides a list of commands and a brief description of each.

**R:** (run) starts the recording process.

**M:** (mode) allows the selection of a variety of triggering modes, including continuous, automatic, and single sweep. (Continuous mode will display the contents of the storage buffer as it is filled; no attempt is made to trigger on the input signal. Automatic mode will attempt to trigger on the input signal and display the data using the pretrigger information; once another trigger occurs, the process is automatically repeated. In the single-sweep mode, only one triggered recording of the input data will be made and displayed; the program then returns to input command mode.)

**C:** (channel) allows the user to change the selection of the input A/D channel for recording; the user can select from channels 0 to 15.

**E:** (end) will end execution of the Scope program, returning control to the Applesoft monitor.

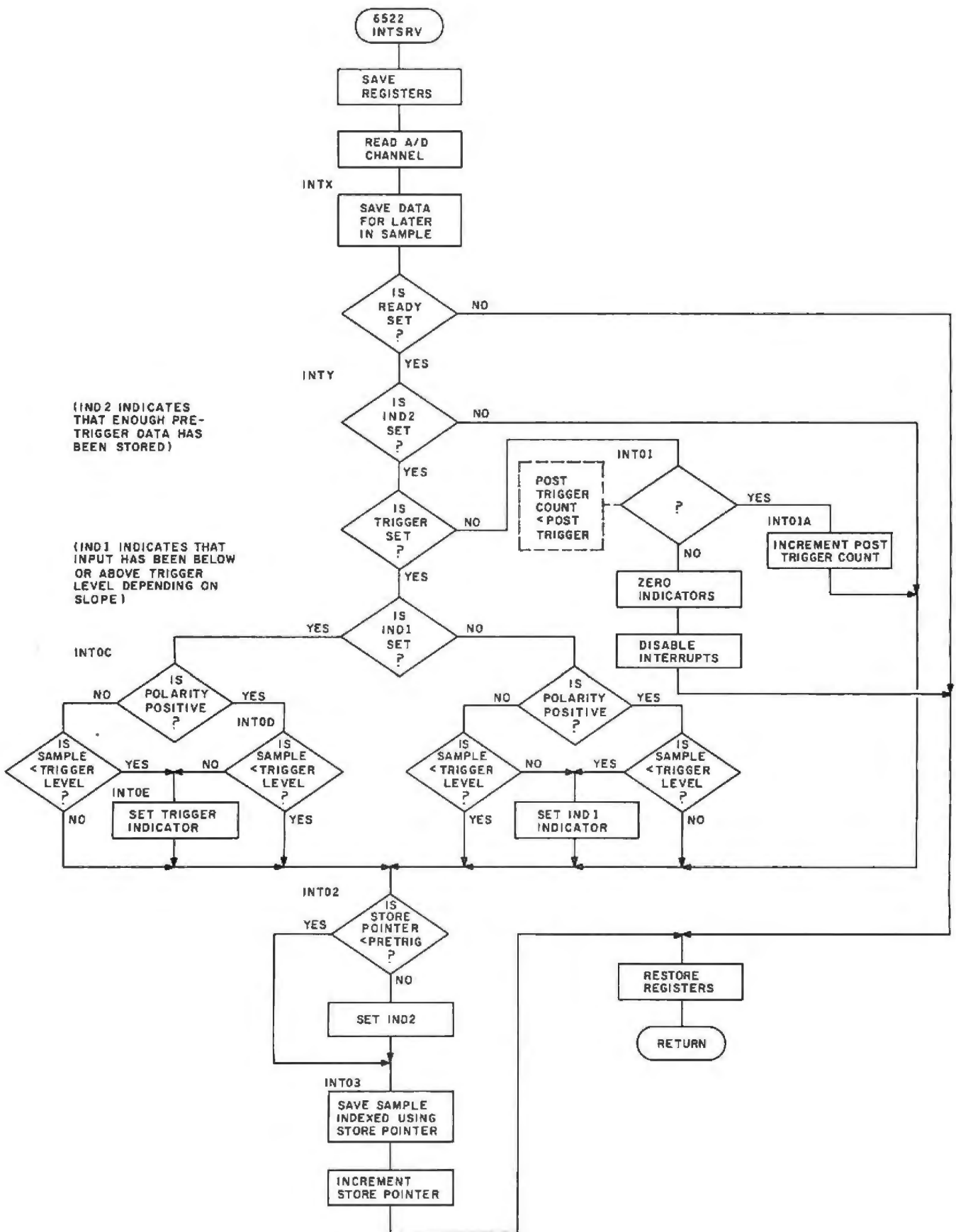
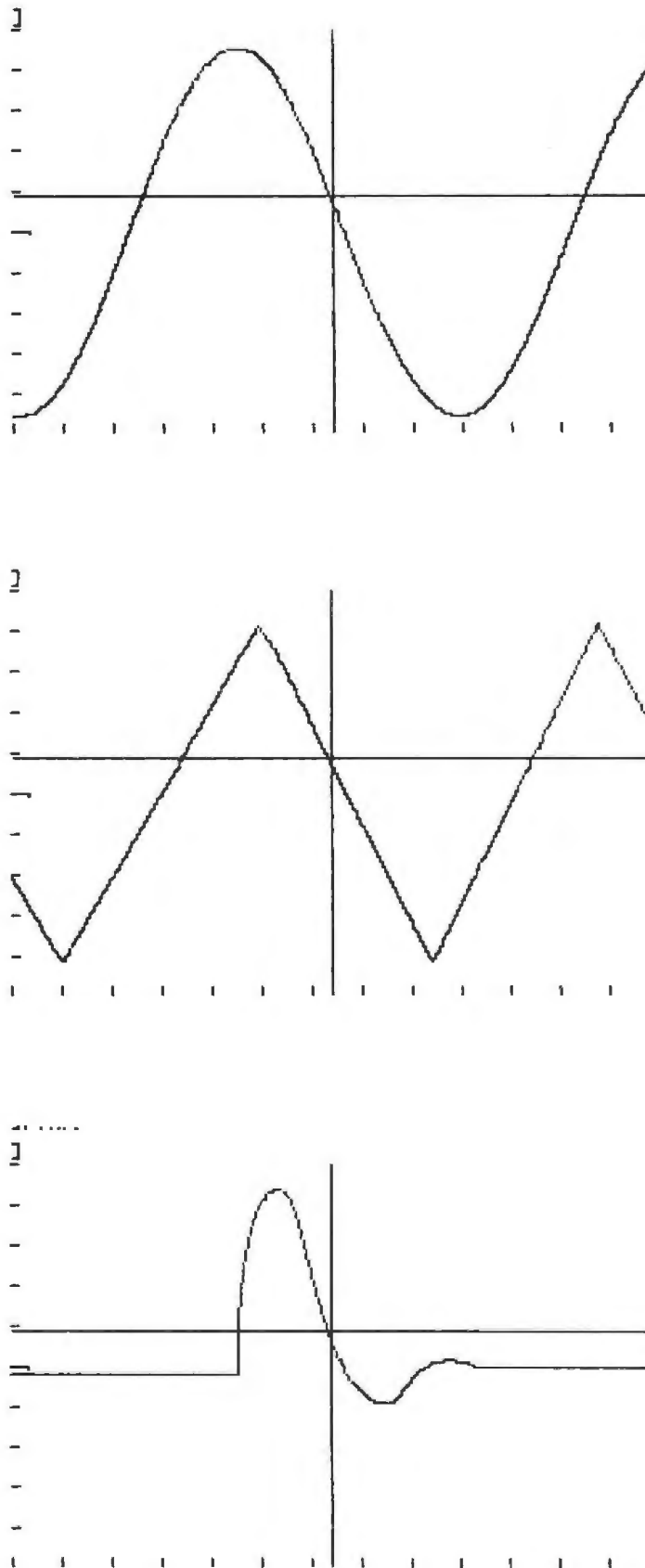

Figure 3: Flowchart of the interrupt-service routine within Adcode (see listing 1b). This routine stores data in Array2 until the trigger conditions are met and the post-trigger samples are accumulated.



When the RUN command is given and automatic mode has been selected, the timer is set and enabled, and the message WAITING FOR TRIGGER appears on the screen. The ready indicator is also set, allowing the Intserv routine to start storing converted data and look for a trigger at the appropriate time. If, during the recording process, any key of the Apple keyboard is depressed, control is passed back to the command portion of the program to allow decoding of the character entered. When the recording cycle is finished, the ready indicator is reset, and the message DISPLAYING SWEEP = *xx* is displayed on the video display. The number *xx* is the horizontal time-scale factor in milliseconds per division. Control now passes to the Trace subroutine.

The other commands are processed in a straightforward fashion. The first action performed by the Trace subroutine is scaling of the input data for display within the 160 vertical divisions of the Apple's screen. Since the data can have one of 256 levels and the display screen is only 160 pixels high, the input data must be appropriately scaled for display. The Trace program uses two 256-byte data buffers, one containing the data just recorded and the other containing the data last displayed. Applesoft graphics subroutines are called to erase the old data on the screen and display the newly acquired data on a point-by-point basis. Once all 255 lines have been drawn on the screen, control passes back to the Scope control program.

It is possible to write an Applesoft BASIC program to scale and display the data; however, display of a single trace would take several seconds. This assembly-language version takes less than a second to trace the stored waveform on the Apple's monitor.

### Application

The Apple II storage oscilloscope is best suited for display of low-frequency, transient signals. To use the program, simply enter RUN SCOPE. Scope will be loaded and it, in turn, will load the object files for

Figure 4: Examples of printed output of the Scope program (the same image is seen on the Apple II's screen). The vertical divisions along the left side of the display represent 1 volt per division. The horizontal scale is indicated on the text line of the display.



# THE MICROCOMPUTER MAGAZINE THAT'S LIGHT YEARS AHEAD

FILL IN AND MAIL  
THIS CARD TODAY

Read your first copy of BYTE, the Small Systems Journal. If it is everything you expected, honor our invoice. If it isn't, just write "cancel" on the invoice and mail it back. You won't be billed, and the first issue is yours at no charge. Allow 6 to 8 weeks for processing your subscription.



4H92

Please print

Name

Address

City

State/Province/Country

Code

**United States**

One year \$19 (12 issues)

Two years \$34

Three years \$49

**Canada or Mexico**

One year \$24 (12 issues)

Two years \$38

Three years \$55

**Foreign Rates** (to expedite service, remit in U.S. funds drawn on a U.S. bank)

Europe, one year, air delivered, \$43

All other countries, one year, surface delivered, \$35

Air delivery available upon request

**Check enclosed** (entitles me to \$13 issues for price of 12, North America only)

Bill VISA

Bill Master Charge

Bill me (North America only)

Card Number

Expires

Signature

Allow 6 to 8 weeks for processing your subscription.

# THE MICROCOMPUTER MAGAZINE THAT'S LIGHT YEARS AHEAD

FILL IN AND MAIL  
THIS CARD TODAY

Read your first copy of BYTE, the Small Systems Journal. If it is everything you expected, honor our invoice. If it isn't, just write "cancel" on the invoice and mail it back. You won't be billed, and the first issue is yours at no charge. Allow 6 to 8 weeks for processing your subscription.



4H92

Please print

Name

Address

City

State/Province/Country

Code

**United States**

One year \$19 (12 issues)

Two years \$34

Three years \$49

**Canada or Mexico**

One year \$24 (12 issues)

Two years \$38

Three years \$55

**Foreign Rates** (to expedite service, remit in U.S. funds drawn on a U.S. bank)

Europe, one year, air delivered, \$43

All other countries, one year, surface delivered, \$35

Air delivery available upon request

**Check enclosed** (entitles me to \$13 issues for price of 12, North America only)

Bill VISA

Bill Master Charge

Bill me (North America only)

Card Number

Expires

Signature

Allow 6 to 8 weeks for processing your subscription.



NO POSTAGE  
NECESSARY  
IF MAILED  
IN THE  
UNITED STATES

**BUSINESS REPLY CARD**

FIRST CLASS PERMIT NO. 39 MARTINSVILLE, NJ

POSTAGE WILL BE PAID BY ADDRESSEE

**BYTE**

Subscription Dept.  
P.O. Box 590  
Martinsville, NJ 08836



NO POSTAGE  
NECESSARY  
IF MAILED  
IN THE  
UNITED STATES

**BUSINESS REPLY CARD**

FIRST CLASS PERMIT NO. 39 MARTINSVILLE, NJ

POSTAGE WILL BE PAID BY ADDRESSEE

**BYTE**

Subscription Dept.  
P.O. Box 590  
Martinsville, NJ 08836

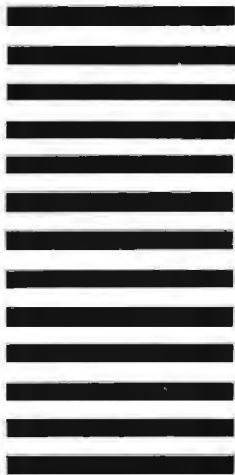

The MICROMINT Z8 BASIC COMPUTER/CONTROLLER board represents a milestone in microcomputer price-performance. It is cheap enough to be programmed directly in a high level language, and efficient enough to be battery operated if required. The entire computer is 4" by 4½" and includes a tiny BASIC interpreter, 4K bytes of program memory, one RS-232 serial port and two parallel ports, plus a variety of other features. Using a powerful Z8 microcomputer chip and Z6132 4K X 8 RAM, the Z8 BASIC COMPUTER/CONTROLLER board is completely self-contained and optimized for use as a dedicated controller. The unit is assembled and tested and comes with over 200 pages of documentation.

**The price, in single quantity, a tiny \$195.\***

Optional power supply (+5, +12 and -12V) \$35.

Please include \$4 for shipping and handling.

\*Call Micromint for quantity pricing

#### Z8 MICROCOMPUTER

- On board tiny BASIC interpreter.
- Parallel and serial I/O ports.
- 6 interrupts.

#### RS-232 CONNECTOR

- Just attach a CRT terminal and immediately write control programs in BASIC.

#### 4K BYTES OF RAM

- Z6132 4K X 8 low power quasi-static RAM. EPROM pin compatible.

#### SWITCH SELECTABLE BAUD RATES

- 110-9600 BPS.

#### FULLY EXPANDABLE

- Data and address buses available for 124K memory and I/O expansion.
- 2 onboard parallel ports.
- 7.3728MHZ crystal for fast control operations.

#### JUMPER SELECTABLE MEMORY OPTIONS

- 4K RAM, 2716 or 2732 EPROM operation.

#### LOW POWER

- Consumes only 1½ WATTS at +5, +12 and -12V (optional power supply available).

To Order:  
Call Toll Free  
1-800-645-3479

For Information Call  
1-516-374-6793

MICROMINT INC.  
917 Midway  
Woodmere, N.Y. 11598

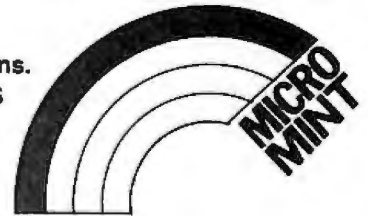

**Micromint will put both a computer development system and an OEM dedicated controller in the palm of your hand for only \$195.**

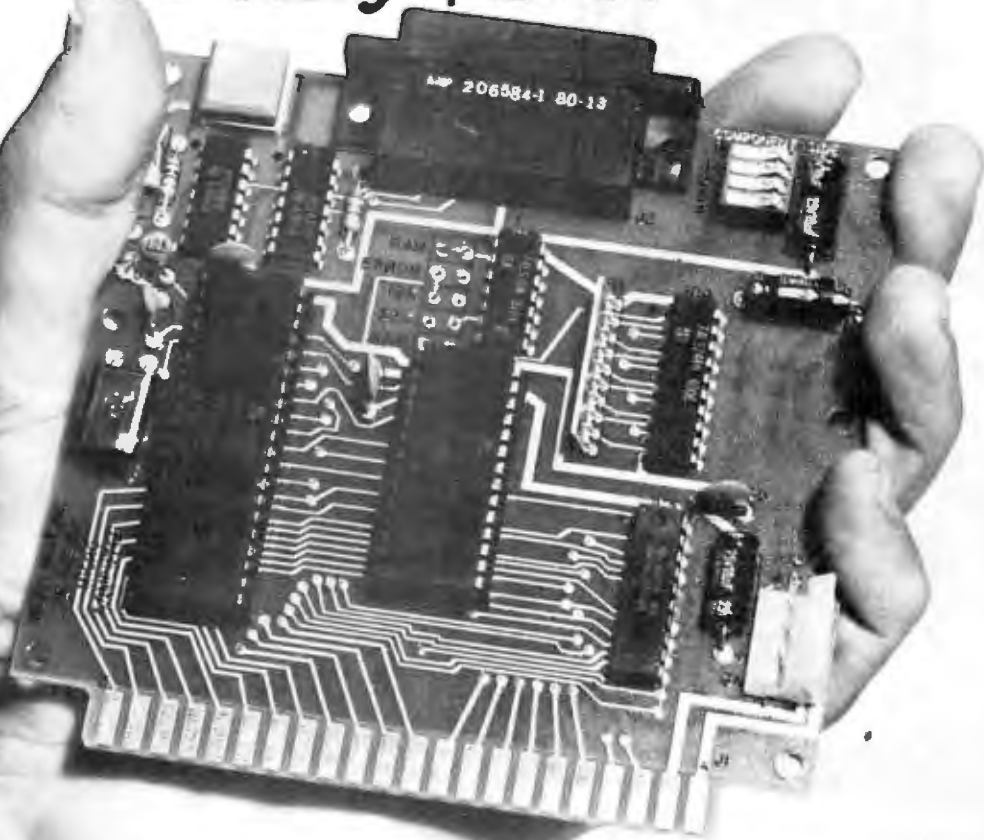

Circle 307 on inquiry card.

As featured in Byte Magazine, July, August, 1981.

Z8 is a trademark of Zilog Inc.

**Listing 2: Sample execution of the Scope program.**

```
JRUN SCOPE
SLOT NUMBER FOR A/D 4
RECORDING CHANNEL 1
INPUT COMMAND
P
PRETRIGGER- 110
INPUT COMMAND
L
TRIGGER LEVEL 165
POLARITY( + / - ) +
INPUT COMMAND
T
SWEEP TIME 3
INPUT COMMAND
H
H=HELP.T=SWEEP TIME,P=PRETRIGGER
L=LEVEL.S=SETTINGS,R=RECORD
M=MODE
T,P,L,M ARE FOLLOWED BY ARGUMENT (REQUEST
ENTER 2.5 TO 1000 FOR T
0 TO 255 FOR P
5, C, OR A FOR M
1 TO 254 FOR L
FOLLOWED BY + OR - FOR SLOPE
INPUT COMMAND
H
SINGLE S, CONTINUOUS C, AUTO A A
INPUT COMMAND
S
SWEEP= 3
PRETRIG= 110
TRIG LVL= 165
INPUT COMMAND
R
WAITING FOR TRIGGER
DISPLAYING SWEEP= 3
```

the two 6502 assembly-language programs, Adcode and Trace. Listing 2 shows a sample run of the Scope program. Examples of the display are shown in figure 4.

**Further Improvements**

The major advantage of the system is the software triggering. You can make trigger-point determination as complex as necessary. It is possible, for instance, to arrange a trigger at a sudden peak or trough of the input signal simply by saving two previous samples and indicating a trigger when the last data point is larger or smaller than the present sample and the second-to-last point. With some software changes, you can also store more than 256 bytes of information, allowing display of data long before or long after the trigger event. However, increasing the complexity of the interrupt-service routine may mean increasing its execution time, which will decrease the maximum sampling rate possible.

Data can be written to disk or tape for later recall, display, or analysis by special routines (e.g., spectral analysis). You can get a multitrace facility by altering Adcode and Trace to handle multiplexing of input data

and displaying multiple lines.

To improve the vertical resolution of the scope display, the time and voltage axes can be interchanged. This will provide a total potential vertical resolution of 280 pixels (although only 256 points will be used), but only 192 sample points can be displayed at a time using high-resolution graphics page 2.

**Conclusion**

The program and hardware described above will convert an Apple II computer into a digital storage oscilloscope. This system provides a scope useful for capturing low-frequency, transient signals (maximum sampling rate of 8 kHz). Higher-frequency periodic signals can be displayed; however, the input-frequency range must be known before recording the signal. Many changes are possible using the present program structure to tailor the instrument to a user's particular need. ■

**VEYTEC, INC.**

**AUTHORIZED DIABLO DISTRIBUTOR**

**"NEW" DIABLO 620 SPI PRINTERS**

**RECEIVE ONLY**

STANDARD RS-232C \$1150  
(Pictured Below)



**DIABLO 630 PRINTERS**

STANDARD R102 SERIAL RO \$1995  
STANDARD R104 SERIAL RO  
(Includes Word Processing Opt) \$2170  
STANDARD K104 SERIAL KSR  
(Includes Word Processing Opt) \$2370

**DIABLO 630 API PRINTERS**

**RECEIVE ONLY**

STANDARD IEEE INTERFACE \$1750  
CENTRONICS PARALLEL INTERFACE \$1750  
STANDARD RS-232C \$1750

**DIABLO PRINTWHEELS**

PLASTIC \$ 5.90 ea  
US 88 CHARACTER METAL \$42.00 ea  
US 96 CHARACTER METAL \$48.00 ea

**DIABLO RIBBONS**

		(1-12 Dozen)	(13-36 Dozen)
301980-04	HYTYPE II	\$4.00 ea	\$3.75 ea
40980	HYTYPE II	\$4.00 ea	\$3.75 ea
38000	HYTYPE I	\$3.50 ea	\$3.10 ea

**DIABLO RIBBONS**

		(1-12 Dozen)	(13-36 Dozen)
38002	HYTYPE I M/S	\$3.50 ea	\$3.10 ea
8R1077	UNIVERSAL	\$6.30 ea	\$5.50 ea
24650-02	MATRIX	\$7.75 ea	\$7.00 ea

942 E. Fairlane Avenue • P.O. Box 13947 • Orlando, Florida 32809 • Phone 305-859-7340  
Inside Florida 800-432-9205 • Outside Florida 800-327-9744

## Pickles & Trout CP/M for the TRS-80 Model II

---

Hal Smith  
Smith Micro Enterprises  
POB 439  
Monett, MO 65708

---

Pickles & Trout has come up with an implementation of CP/M for the TRS-80 that leaves all others far behind. Our firm purchased a Model II because of its local service availability. We quickly found that TRSDOS (the standard operating system for the Model II) was not adequate for our needs. Looking for an alternative, we discovered Pickles & Trout CP/M 2.2, an adaptation of Digital Research's CP/M for the TRS-80 Model II. (For a comparison of TRSDOS vs. CP/M features, see table 1.)

### Documentation

The package comes with the usual seven manuals from Digital Research Corporation as well as Pickles & Trout's own 150-page manual, which is concise and well written. (At this writing, Pickles & Trout is preparing a new manual.) All of the major stumbling blocks of getting a CP/M-based system started up are covered in Pickles & Trout's manual. It also provides useful examples of actual programs.

In the area of user interface with CP/M, the Pickles & Trout manual is fairly complete and refers those who need more information to the appropriate section of the Digital Research manuals. As well, the Pickles & Trout manual explains the exact function of each peripheral device and specifies the control codes that operate the screen functions, the characters that the keyboard sends, the details of the serial port drivers, and the Centronics parallel port drivers.

The concern that Pickles & Trout has for the new CP/M user is obvious. The section "Getting on the Air" (i.e., getting started) takes the first-time user from turning the computer on to making a working master system disk. Pickles & Trout manuals are a joy to read.

### At a Glance

**Name**

Pickles & Trout CP/M 2.2 for the TRS-80 Model II

**Type**

CP/M operating system

**Manufacturer**

Pickles & Trout  
POB 1206  
Goleta, CA 93116  
(805) 685-4641

**Price**

Standard version	\$ 185
Double-sided version	\$220
Cameo hard-disk version	\$250
Corvus hard-disk version	\$250
Manuals only	\$ 35

(cost may be applied to purchase of Pickles & Trout CP/M 2.2 for a 6-month period)

**Format**

8-inch disk, soft sector

**Language**

Z80 and 8080 assembly

**Computer**

Radio Shack TRS-80 Model II, 32 or 64K bytes of memory

**Documentation**

Standard 7 CP/M manuals; more than 150 pages of bound manual and supplements from Pickles & Trout

**Audience**

TRS-80 Model II CP/M users

They explain the underlying concepts in terms that the beginning user can understand, but with enough detail so that the sophisticated user can use the full features and functions of the Model II.

TRSDOS 2.0a	Pickles & Trout CP/M version 2.2	Comments
AGAIN	none	
ANALYZE	STAT	partial equivalent (note 1)
APPEND	PIP	
ATTRIB	STAT	
AUTO	AUTOEXEC	
BUILD	ED	ED more powerful than BUILD
CLEAR	none	
CLOCK	various TIME functions	
CLS	none	
COPY	PIP, FASTCOPY	
CREATE	none	
DATE	various DATE functions	
DEBUG	DDT	
DO	SUBMIT, XSUB	printer echoes
DUAL	Control-P	display
DUMP	SAVE	
ECHO	none	
ERROR	none	
FORMS	SETMISC	
FREE	STAT	
HELP	none	
HOST	PIP	(note 2)
	Control-C	warm boot
KILL	ERA	
LIB	none	
LIST	TYPE, DUMP	
LOAD	DDT	
MOVE	PIP, FASTCOPY	
PAUSE	none	
PRINT	TYPE, PIP	
PROT	none	
PURGE	ERA	
RECEIVE	PIP	(note 2)
RENAME	REN	
RESET	none	
SCREEN	none	
SETCOM	SETUP	
SPOOL	DESPOOL	output from disk text file only
STATUS	none	
TIME	various TIME functions	
T	none	
VERIFY	none	(note 3)

Notes

1. FCBS from PUI User's Group adds remaining features.
2. Subject to certain limitations in data format and flexibility.
3. Normally always verify after write; may be enabled in PIP at user option.

**Table 1: A comparison of the functions of TRSDOS 2.0a (Model II) to its nearest analogs in Pickles & Trout CP/M.**

## Hardware Options

Pickles & Trout has provided some things that Tandy did not. An option (at \$175) is a board called the CCB-II, which supports a clock, a calendar, and a bell tone, and fits into the Model II card cage. For an additional \$5, Pickles & Trout provides a TRSDOS disk with support routines for the CCB-II for both CP/M and TRSDOS.

The system features are listed in table 2. In addition to the standard Radio Shack configuration, Pickles & Trout supports double-density double-sided drives and the

<p><b>Disk Storage</b></p> <ul style="list-style-type: none"> <li>596K bytes on single-sided disks</li> <li>1.2 megabytes on double-sided disks</li> <li>10-80 megabytes on hard-disk controller</li> <li>automatic density select on floppy drives</li> <li>multidrive emulation on single-drive system</li> <li>floppy head step times of 3, 6, 10, and 15 milliseconds, by drive</li> </ul>
<p><b>System</b></p> <ul style="list-style-type: none"> <li>8K-byte system, leaving up to 56K bytes for transient programs</li> <li>system size can be changed to leave area for special routines</li> <li>27 additional special functions</li> <li>provision for real-time clock service routines</li> <li>full compatibility with existing CP/M software</li> <li>over 20 additional utilities for the Model II</li> </ul>
<p><b>Input/Output</b></p> <ul style="list-style-type: none"> <li>full-function video-display control, including: <ul style="list-style-type: none"> <li>carriage return, linefeed, tab, backspace, delete</li> <li>clear screen, clear to end of line, clear to end of screen</li> <li>insert and delete line</li> <li>cursor left, right, up, and down</li> <li>reverse video and graphics</li> <li>wrap or nonwrap at end of screen line</li> <li>direct cursor addressing, direct access to screen</li> <li>read cursor x-y location, read character at cursor</li> <li>scroll protect top of screen (0 to 23 lines)</li> <li>set size and blink of cursor, set blink rate of cursor</li> <li>set cursor off or on</li> </ul> </li> </ul>
<p><b>Serial Ports</b></p> <ul style="list-style-type: none"> <li>normal CP/M access</li> <li>special application direct access</li> <li>handshaking: ETX/ACK, XON/XOFF, clear-to-send and data-carrier-detect</li> <li>data rates: 110, 134.5, 150, 300, 600, 1200, 2400, 4800, 9600 bps</li> <li>stop bits: 1, 1½, 2</li> <li>parity: even, odd, none</li> <li>word length: 5, 6, 7, 8 bits</li> <li>RS-232C status line RTS and DTR: high or low</li> </ul>
<p><b>Keyboard</b></p> <ul style="list-style-type: none"> <li>64-character type-ahead buffer</li> <li>"Break" key enable/disable</li> <li>Hold key functional for standard console I/O</li> </ul>
<p><b>Clock/Calendar</b></p> <ul style="list-style-type: none"> <li>standard system functions</li> <li>0.01 second resolution</li> <li>hardware date and time support available (CCB-II option)</li> </ul>
<p><b>Centronics Port</b></p> <ul style="list-style-type: none"> <li>formfeed emulation</li> <li>automatic linefeed emulation</li> <li>automatic linefeed after carriage return may be software suppressed</li> </ul>

**Table 2: An overview of the features available in Pickles & Trout CP/M for the TRS-80 Model II.**

Cameo hard-disk or Corvus hard-disk systems with up to four drives. They are currently examining implementation of support for the Radio Shack hard disk as well.

Using Pickles & Trout CP/M, the system can be set up for from one to four drives in a normal configuration. After the sign-on message with the copyright notices, it asks you how many drives the system has. If the answer is one, the system lets you use four logical drives, even though there is only one physical drive, and it prompts you whenever a change is needed. This is the simplest method I've seen to support multiple-disk operation on one drive.

In addition to the (often cryptic) BDOS (basic disk operating system) error message, Pickles & Trout's error interface returns a status byte, which directs you to the manual for additional information about the error.

## Utilities

Pickles & Trout has made its utilities as goof-proof as possible without making them difficult to use. The utilities are uniform in approach to operation and are all well prompted.

The RESIZER utility, which Pickles & Trout supplies instead of SYSGEN and MOVCPM, generates a CP/M system that can vary from 20 to 64K bytes in 256-byte increments. This allows you to set aside space above CP/M for special drivers, patches, applications, or other routines. A 64K-byte system gives a 56K-byte transient program area. Also, Pickles & Trout provides the information that makes it possible for you to find the amount of space between the end of the operating system and the end of memory. Short routines may reside there; the only shortcoming is that whenever the system changes, the available address space changes.

RESIZER will run only from the licensed issue disk. It will not run if it is not on the original systems disk. This prevents you from backing up the operating system without the original systems disk and makes it difficult for a pirate to make a copy. And with the serial number buried in the operating system, tracing pirated copies is easy.

The FORMAT utility lets you format either a standard single-density CP/M disk or a double-density disk. The double-density disk holds 600K bytes, of which 596K bytes are user-accessible; 4K bytes are used for the directory maximum of 128 entries. The double-density format is the standard for Pickles & Trout CP/M. This gives Model II users at least 60 percent more usable disk space than they would have with the TRSDOS 2.0a.

Along with the FORMAT utility are the disk test and certification routines. DENSITY lets you check a disk for a specified density and change the density flag if needed. DDTEST and SDTEST are destructive tests of the media. They write several patterns of bits to all tracks of the disk, recording hard and soft errors on the screen as well as displaying the progress of the test. DD CHECK and SD CHECK are similar, but nondestructive, tests of the media which also notify you of potential media-related errors.

## Other Utilities

The SETUP utility is a useful tool for working with the serial ports. It can be used to change the data rate, number of bits in a word, stop bits, parity, and handshaking protocol for the serial ports. It also displays the current serial port status without altering the values. In addition, SETUP displays the current IOBYTE status and allows it to be changed.

SETUP is the easiest utility that you can find. It uses the keyboard arrow keys to move the cursor from option to option. The current option is highlighted in reverse video. An advantage of using reverse video is that it is easy to identify the current settings. You can then press Control-Q to exit, Control-S to change a parameter; or you can press Control-X to set the parameters and then exit SETUP.

STAT, PIP, ED, ASM, DDT, SUBMIT, and XSUB are the standard transient programs furnished by Digital Research. Pickles & Trout's explanations of them are the most concise that I have seen, and this includes some of the new CP/M books.

SETTIME, SETDATE, TIME, and DATIME are utilities to set and return the system time and date. If you have the CCB-II board installed, SETCCB allows you to set that device also. I have found it advantageous for some applications to set the system time and date to *virtual* values, while the CCB-II maintains the actual values.

## SPECIAL ANNOUNCEMENT

### The IBM Personal Computer is here

#### FREDERICK COMPUTER PRODUCTS

has been selected as an Authorized Dealer and Service  
Center for the IBM Personal Computer.



If you thought IBM only made big computers for big companies, this new IBM Personal Computer will change your mind.

It can also change the way you work, organize, play, learn, accomplish and achieve. Come in today and we'll personally show you how.

With self-running demonstrations, you'll learn how the new IBM Personal Computer can help with everything from general ledger and accounting to planning, financial modeling, sales forecasting and trend analysis. You'll also learn about all the advanced features that set this new personal computer apart.

And don't worry if you've never had your hands on a computer before. You see, IBM made its personal computer so advanced, it's amazingly easy to use. It's also easy to buy.

Because the IBM Personal Computer that's here at our store starts at \$1,365.00.

#### FREDERICK COMPUTER PRODUCTS, INC.

MICRO-COMPUTER SYSTEMS & PERIPHERALS

5726 INDUSTRY LANE • FREDERICK, MARYLAND 21701 • 301 694 8884

## An IMPORTANT ANNOUNCEMENT

by AdaVISION<sup>™</sup>, Inc.

The FIRST COMPLETE INTRODUCTORY  
VIDEOTAPE COURSE in

# ADA\*

16 Studio-produced COLOR Videocassettes  
and complete Study Guide

ADA is the CHALLENGE of the EIGHTIES and NINETIES!

Projections indicate that ADA will be the DOMINANT  
COMPUTER LANGUAGE DURING the 1980's and BEYOND!

The ADA Tapes Studio-Produced, Color Videotape Series is the simplest,  
most economical and effective way to learn the ADA computer language now, for  
education, industry and government! Train your entire staff on site, at your  
office!

ADA Tapes are available right now to teach you all you need to know about  
ADA.

Unlike seminars and college courses, always expensive and frequently  
unrewarding, no additional expense need be incurred by having your own  
personnel attend the ADA Video Course in your own office or home environ-  
ment! Repeat the course as often as you want, and at your own pace!

As a company, you want to insure your future in our western industrial world.  
In the 1980's, ADA will become the standard, universal programming lan-  
guage for industry. Your company's ability to respond to critical contract  
offerings will become increasingly dependent on how much you and your  
personnel know about ADA!

As an individual programmer or data processing manager, you want to  
assure yourself of a high salary in the years to come. You must learn ADA!  
Knowing ADA is your best insurance for the future. (Better take this ad to your  
DP Manager!)

No other computer language that was ever conceived even begins to com-  
pare with the power of ADA! ADA is the result of a refining process in which 17  
original companies — the best software houses on earth — competed to  
capture an immense software development contract. Only 4 finalists emerged.  
Of these four, only one survived! The result was . . . ADA!

ADA is beautiful!! This new language is destined to play a major role in all  
future systems. Engineering, mathematics, accounting, embedded systems,  
machine tool control — no matter what the application! ADA embodies the  
finest features of all other languages, but with superior modularity, portability  
and standardization!

The tasking and separate compilation capabilities of ADA in the '80's are what  
Real Time Programming and Top Down Structure were to the '70's! ADA will be  
uniformly transportable among all processors! ADA is ADA — for all  
processors!

This course has been carefully designed so as to be equally valuable to the  
programmer well versed in Top-Down Structure concepts, and to the novice  
wishing to begin his programming career using the latest software technology.

The team that created this course combines more than 80 man-years of  
experience in programming languages and tape based teaching concepts. The  
course lecturer alone brings more than 25 years of experience in developing  
compiler languages and teaching computer science.

The cost of the entire ADA course is \$4800 for sixteen color videotape  
cassettes, in any format required — and more than 12 clock hours of intensive  
ADA instruction!

There are hundreds of example code segments, including many complete  
programs, each with a thorough explanation. The comprehensive ADA Study  
Guide accompanying the video cassettes runs parallel with the videotape pre-  
sentation throughout the entire course.

To order the complete "Comprehensive Course in the ADA  
Programming Language", Send Coupon below to:

**AdaVISION, Inc.**

P.O. Box 43195

Renaissance Center, Detroit, MI 48243

(NOTE: Extra Study Guides are available at \$30.00 per copy. Quantity discounts  
are available upon request.)

C.O.D.

Check enclosed \$4800.00

(Michigan residents add 4% State Sales Tax)

Ship ( ) ADA Videotape Courses to:

Name \_\_\_\_\_

Title: \_\_\_\_\_

Address: \_\_\_\_\_

City: \_\_\_\_\_

State: \_\_\_\_\_

Zip: \_\_\_\_\_

Videotape Format:

1/2" VHS

1/2" BetaMax

3/4" U-Matic

\*Ada is a trademark of the Department of Defense (Ada Joint Program Office)

This lets you "fib" to an application program and then restore the proper time and date later. SYNCHRO is a program that will synchronize the system clock and the CCB-II. This ensures that the system clock will remain accurate, even though there is some slippage (about 0.16 percent) between the system time and the actual elapsed time. There is a provision in the time-of-day clock to roll the system date forward if the system time goes past midnight, as well as a provision for leap years.

Another nice utility that Pickles & Trout offers in the area of timekeeping is the information you need to perform a timer-interrupt routine. The system clock ticks in intervals of 0.01 seconds. The interval to call the interrupt-service routine can be from 1 to 65,535 ticks or 0.01 to 655.35 seconds. This makes polling functions, response time limits, and other time-measurement functions easier to implement at the CP/M system level.

## SETMISC allows you to change all of the system's miscellaneous I/O parameters from the console.

Pickles & Trout hasn't forgotten overseas users, either. A function called HERTZ allows you to set up the system for 50 or 60 Hz operation.

Another Pickles & Trout utility, SETMISC, lets you change all of the system's miscellaneous I/O (input/output) parameters from the console. In the screen area, line-wrap of the console can be set on or off, the cursor size varied, or the cursor blink rate altered. In addition, the cursor can be turned off and the Z80 I/O port of the CCB-II can be set.

For disk drives, SETMISC allows the drive-head stepping times to be set individually, by drive, for a 3-, 6-, 10- or 15-ms (millisecond) step rate. This lets you fine-tune your system performance. We have a rare Model II that can step all drive heads at 6 ms. Our local Radio Shack dealer's Model II will step at 6 ms for the built-in drive, but his outboard drives will not move faster than 10 ms.

SETMISC allows the Centronics parallel port options to be configured very conveniently. Tandy printers supply an automatic linefeed (LF) after a carriage return (CR). Many other printers do not, so most of the available software adds a linefeed after the carriage return. If you are using a Tandy printer, it will give double-spaced output. Pickles & Trout's Centronics driver can be set to ignore that extra linefeed. One minor bug that exists when you are suppressing the extra linefeeds is in LLISTING MBASIC programs. Linefeeds in program lines are reversed to LF/CR pairs instead of the normal CR/LF pair. This confuses the printer driver, so the LLISTING of MBASIC programs with the embedded linefeeds will include additional line spaces if the automatic linefeed suppression is selected.



For printers that do not have the formfeed function, Pickles & Trout's driver will count lines and perform a formfeed emulation by generating the appropriate number of linefeeds. The form length can be set for between 0 and 254 lines. In addition, a second counter will count the number of lines before an automatic formfeed. This function can also be enabled or disabled for automatic formfeed.

Both SETUP and SETMISC alter system parameters temporarily. If you want to make these changes permanent, Pickles & Trout CP/M provides a function called IOFREEZE which permanently sets the I/O and system parameters into the system disk. It also sets the number of disks query to default to 0 through 4. If you answer from 1 through 4, the system assumes you have that number of drives. If, however, 0 is specified, the system interrogates the console at a *hard boot*.

### FASTCOPY copies all files of all users and is much more efficient than PIP for moving files.

Speaking of boots, I would define three types: warm, cold, and hard. The warm boot is the standard one where only the Console Command Processor (CCP) is reloaded (i.e., a Control-C). The cold boot reloads the whole CP/M system, including the CCP, the BDOS, and the BIOS (basic input/output system). The difference between a hard boot and a cold boot is that a hard boot will occur only if the boot ROM (read-only memory) in the Model II is first enabled and then the CP/M system is loaded and begins execution—typically upon pressing the Reset button. A cold boot can be called by a standard system function, but the boot ROM is not enabled as it would be if the Reset button were engaged.

Pickles & Trout provides an automatic execution function called AUTOEXEC. This function provides for automatic loading of a CCP command and invocation by the system. The options are *never*, *cold only*, and *warm and cold boots*, which is why I define Pickles & Trout CP/M to have three types of boots. If the AUTOEXEC is selected for warm and cold, the function is invoked at either cold or warm boot. If the AUTOEXEC time is set to cold, the only time that you see the function is at initial start-up or after the Reset switch has been pressed. If your application program performs a cold boot, AUTOEXEC will not be invoked.

Another special feature is FASTCOPY, a utility that will copy all files from one disk to another. It copies regardless of the user number, the system/directory flag, and the read/write status. FASTCOPY copies all files of all users, unlike PIP, which must be forced to read a system file or the file of another user and will not overwrite a read-only file. FASTCOPY uses the standard CP/M calls, so that if the extents in the source disk are

## IBM /8088 PORTABLE Personal Computer



with

### COLOR GRAPHICS

### IBM /8088 PC SYSTEM

- INTEGRAL 7 IN./9 IN. COLOR CRT
- DETACHABLE IBM A-N KEYBOARD
- IBM COMPATIBLE & CP-M80/86, DOS
- COMPACT PORTABLE ENCLOSURE

#### O - IBM PERIPHERAL FEATURES

P - DUAL 5 1/4" DISK DRIVES - 1 M.

T - WINCHESTER DISK - TO 20 M.

I - HI-RES. GRAPHICS/B & G CRT

O - 280 DUAL-PROCESSORS

N - MULTI-TASKING SYSTEMS

S - IBM DATA COMMUNICATIONS

- MONITORS -  
9, 13 or 19" CRT  
RGB Color  
Hi-Res Remote/  
Receiver

ASC  
Computers

26401 HARPER  
ST. CLAIR SHORES  
MI 48081

313  
779-8700

# ECT™

## Building Blocks for Microcomputer Systems, Dedicated Controllers and Test Equipment

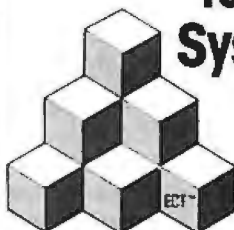

S-100  
64K  
STATIC  
RAM



ECT's 64K STATIC RAM is a low power fully static 64K x 8 bit S-100 Bus Memory Board. 2716 EPROM's can be intermixed with the RAM's.

\$479.00

# ECT™

Specializing in Quality Microcomputer Hardware  
Industrial • Educational • Small Business • Personal  
Card Cages, Power Supplies, Mainframes, CPU's,  
Memory, I/O, OEM Variations

## ELECTRONIC CONTROL TECHNOLOGY, INC.

763 Ramsey Ave., Hillside, NJ 07205 (201) 686-8080

Function Number	Name of Function	Description
0	Set up serial ports	Sets all serial port parameters
1	Read character from port A	Reads data from and status of serial port A
2	Read character from port B	Reads data from and status of serial port B
3	Output character to port A	Outputs a character and returns status—serial port A
4	Output character to port B	Outputs a character and returns status—serial port B
5	Read serial port A status	Makes status of serial port A available
6	Read serial port B status	Makes status of serial port B available
7	Read Centronics port status	Reads status of hardware, Centronics parallel port
8	Send character to Centronics port	Bypasses CP/M input/output routines—parallel port
9	Set Centronics port options	Sets linefeed and formfeed options—parallel port
10	Set Centronics port length	Sets form length for software control—parallel port
11	Set Centronics printed lines per page	Sets number of lines before automatic linefeed—parallel port
12	Set Centronics top of page	Sets current physical line to top of page—parallel port
13	Set all drives to unknown density	Forces density determination at next disk access
14	Read real-time clock	Returns 4-byte tick count clock value
15	Read time-of-day clock	Returns time of day in 24-hour format
16	Set time-of-day clock	Resets current value of time-of-day clock
17	Read x-y of cursor	Returns current row and column of screen cursor
18	Read character at current cursor location	Reads character at row/column and bit 7 on if reverse video
19	Set size and blink of cursor	Sets 0 to 9 pixels high, off, nonflashing, slow or fast flash
20	Set cursor blink and on/off	Sets as above, without altering cursor size
21	Enable access to screen	Switches screen into Z80 address space
22	Disable access to screen	Switches normal memory back in
23	Set split screen mode	Protects top of screen from line 0 to 23
24	Read system date	Returns day of week, day of month, month, and year
25	Set system date	Resets current system date
26	Set console Control-C trap	Enables/disables break function filter in console handler

**Table 3:** Special system calls offered in the Pickles & Trout version of CP/M. These functions can be called from within high-level languages.

fragmented and scattered all over the disk, FASTCOPY will lay the copied file down sequentially on a clean disk. If you are copying to a partially full disk, some fragmentation may occur because FASTCOPY deletes the name of a destination file from the destination disk before writing the copy. Still, FASTCOPY is extremely useful in both single-drive and multiple-drive systems because it is so much more efficient than PIP for moving files.

TRS2CPM is handy for files and programs that run under TRSDOS. TRS2CPM allows you to move a file from a TRSDOS disk to a CP/M disk. It displays the files on the TRSDOS disk and allows you to choose the ones to move. If the file is a text file, you have the option of supplying a linefeed after each carriage return. If the file is an executable file, the load and execute addresses are displayed. If the file is a data file, the size is displayed.

For programmers writing application programs that access the BIOS, Pickles & Trout has provided complete implementation of the normal CP/M BIOS jump vector and included five additional BIOS calls. The additional calls support I/O to the serial ports and user I/O functions, with the addition of a supplemental user I/O device table.

Another feature I particularly like about Pickles & Trout CP/M is that it has a very good implementation of the Hold key, which can be used to start and stop execution and scrolling. You don't have to press a Control-S to stop scrolling or program execution, then press any key to resume, as with standard CP/Ms.

The area where Pickles & Trout really stands head and shoulders above all other Model II CP/Ms is special system calls. It has an interface at hexadecimal 40 on page 0 that is called in a manner similar to the BDOS entry point at hexadecimal 05. Parameters are passed to the special system calls for 26 functions in a manner similar to CP/M. The special system calls can be invoked at the assembly-language level or from a high-level language. I found it very easy to interface in BASIC and PL/I. The functions available are listed in table 3.

### Conclusions

Pickles & Trout gives the information necessary for users of CP/M packages such as Magic Wand and Wordstar, which allow them to be used effectively. It also provides hexadecimal files and data files so beginners can set up these and other packages with a minimum of effort.

Pickles & Trout provides the kind of vendor support that everyone dreams of. The company's technical people can answer most questions immediately, and if you have a complex problem they will generally get back to you in short order with a solution or suggestion.

Pickles & Trout CP/M is indeed the Cadillac of Model II CP/Ms. It has all of the features that a serious Model II user looks for in addition to being well documented and supported. I have not found an application package that cannot run under it. We do indeed have a gourmet delight in Pickles & Trout CP/M. ■

## TRS-80 Disk Editor/Assemblers

T.A. Daneliuk  
4927 North Rockwell  
Chicago, IL 60625

Assembly-language programming is an exacting skill that can try the patience of even the best programmer. A good editor/assembler package can make this difficult and tedious procedure more efficient, but a poorly thought-out package can discourage the novice from ever really trying to learn assembly language. Presented here are two assembly-language packages implemented on the TRS-80 Models I and III. They differ substantially in price, but each offers features sure to appeal to particular programming tastes.

### Series I Editor/Assembler

From the beginning, Radio Shack offered Disk Editor/Assembler, a moderately priced assembly-language package for the Model I, but it was restricted to saving source

and object files on cassette. The user of the disk-based system was offered only the vastly more complex macro assembler. Then Radio Shack introduced the Model III, and unfortunately neither of these packages would work with the new computer. The Series I Editor/Assembler is Radio Shack's answer to these problems and is available for either the Model I or the Model III in disk or cassette version.

If you're familiar with the TRS-80 BASIC editor, you should be right at home with the Series I editor. The line-editing subcommands are virtually identical to those of BASIC. The editor also provides all the necessary commands to manipulate and display whole groups of lines. Lines of source code may be listed on the screen, deleted, printed, and renumbered. Also available are commands to insert new lines, load source files from disk, display memory status, replace lines, write source files to disk, and find a particular string of text within a group of lines. The latter command facilitates the editing of extremely long source files. The editor is easy to use, and the documentation is sprinkled with helpful examples. One rather nice feature of this editor is that it will automatically renumber the lines involved if a "line-collision" occurs; i.e., if you try to write a source statement to a line number that already exists, the lines will be renumbered to accommodate both the original line and the addition.

The Series I assembler appears to be a disk version of the older Model I cassette editor/assembler. All the Z80 mnemonics are supported and the following pseudo-operations are implemented: ORG, EQU, DEFL, END, DEFB, DEFW, DEFS, and DEFM.

The assembly itself is controlled by a set of "switches" that control the following: output of assembled code to the line printer, waiting on errors, creating a symbol table, and establishing whether to list the assembly to the

### At a Glance

<b>Name</b> Series I Editor/Assembler	<b>Language</b> Z80 machine-language
<b>Type</b> Assembly-language programming package	<b>Computer</b> TRS-80 Model I or III with one disk drive or cassette recorder.
<b>Format</b> 5¼-inch disk	<b>Documentation</b> 255 pages in a 3-ring binder
<b>Manufacturer</b> Radio Shack Division of Tandy Corp. One Tandy Center Fort Worth, TX 76102 (817) 390-3011	<b>Audience</b> Present and would-be assembly-language programmers
<b>Price</b> \$34.95 for disk, \$29.95 for cassette	

## At a Glance

<b>Name</b> EDAS	<b>Language</b> Z80 machine-language
<b>Type</b> Assembly-language programming package	<b>Computer</b> TRS-80 Model I or III with one disk drive
<b>Format</b> 5¼-inch disk	<b>Documentation</b> Approximately 50 pages in a 3-ring binder
<b>Manufacturer</b> Misosys 5904 Edgehill Drive Alexandria, VA 22303 (703) 960-2998	<b>Audience</b> Present and would-be assembly-language programmers
<b>Price</b> \$79.00	

screen and whether to output object code. The assembler also recognizes the LIST ON and LIST OFF commands to control the listing of the file during assembly. Finally, addition, subtraction, negation, logical AND, left shift, and right shift are all allowed in a source statement. Symbolic labels up to six alphanumeric characters in length are also allowed.

On the Model I, the disk version runs under TRSDOS 2.3B (supplied with the assembler) which is incompatible with the older TRSDOS 2.3. Provision is made to transfer files from the older TRSDOS to version 2.3B, but not to transfer files back to TRSDOS 2.3. Object code can be saved to the older DOS by using the DUMP command. Provision is also made to transfer source and object programs generated from the tape editor/assemblers to disk. The Model III version runs under TRSDOS 1.3.

The documentation of this package is very good, and the index is especially thorough and helpful. Included are many examples of the various editor/assembler commands, as well as in-depth discussions of each Z80 instruction. However, the documentation itself is not a tutorial in assembly-language programming, and novice assembly-language programmers will need supplemental study material.

## EDAS

The EDAS editor/assembler is destined to become a real favorite with both the novice and the expert programmer. It offers tremendous power and ease of use, and has all the features of the Series I Editor/Assembler described above and many more.

When EDAS is first loaded three options are available that, to my knowledge, are not available in any other package. Memory size may be specified, as in BASIC, to protect high memory from EDAS. You may request a prompt at the end of each printed page; this option, important when using single-sheet-fed printers, causes EDAS to wait for your signal to resume printing. Finally,

EDAS may be run under a job control language such as is used with LDOS. This permits complete "hands-off" assembly of source files.

As with the Series I package, EDAS has an editor that is almost identical to the Level II BASIC editor. But while the EDAS editor includes those features found in Series I, many capabilities have been added to make the EDAS version an extremely powerful editor. These include direct branching to a memory location to begin execution, globally changing an existing string of text to a new string of text, finding a specified string of characters, killing a file on a disk, moving a block of text from one location to another, displaying a directory of a drive while in EDAS, sending source code without line numbers to a printer, viewing a file on a disk without loading it into the text buffer, and altering the lines and page of the line printer listings. EDAS also supports labels up to 14 characters long.

The assembler itself also has all the features of Series I but adds many of its own. Using the assembly "switches," it is possible to assemble the code directly into memory and execute a program by means of the branch command. It is also possible to specify a switch that suppresses the object listing of DEFM, DEFB, and DEFW pseudo-operations, which makes the listings a little neater. Finally, a switch to generate a cross-reference file is provided. EDAS comes with a cross-reference utility which generates a listing of symbols used in the source program. This greatly aids the debugging and writing of documentation for long programs.

In addition to the arithmetic and logical operations described above for Series I, EDAS supports multiplication, division, modulo, logical OR, and logical XOR. The pseudo-operations have also been augmented with the following:

TITLE: to title listing pages  
SUBTTL: for subtitles on the listings  
PAGE: to force a new listing page  
COM: to generate comment blocks in the listing  
SPACE: to force line spacing in listings  
ERR: to generate error messages during assembly  
IF and ENDIF: to generate conditional assemblies

One other pseudo-operation of interest is \*GET. This command allows source files to be called from the disks during assembly. In effect, \*GET handles assembling of source files that are too long to reside in memory. In fact, it is possible to put nothing but \*GET commands and an END statement into the text buffer and initiate assembly. This allows all the memory space available to be used as a huge symbol table.

In addition to the cross-reference utility, EDAS comes with a CMDFILE utility, a general-purpose tape-to-disk, disk-to-tape, and disk-to-disk transfer utility. Among its many features, CMDFILE has the ability to take multiple SYSTEM tapes and append them together to create one large system tape or disk /CMD file. Also included is a

tape-to-disk utility called TTD that allows transferring files created under Radio Shack's EDTASM or Microsoft's EDTASM+ to disk for manipulation by EDAS.

EDAS runs under TRSDOS 2.3 and LDOS. It does *not* work under NEWDOS 80. Misosys claims that the problem is in NEWDOS 80, which doesn't have a certain vector that is in TRSDOS 2.3 and LDOS. Consequently, EDAS cannot be patched to run under NEWDOS 80.

The documentation for EDAS is excellent, although it doesn't have the detailed discussion of the Z80 op codes that Series I has, and there is no index. However, there is a discussion of the technical aspects of the file formats of EDAS source and object files, as well as how to link to the debugger in the DOS. Each major command is presented with a description of its function and several examples of its use.

### Conclusions

It is almost impossible to draw direct comparisons between the Series I and EDAS packages because they differ considerably in price and complexity. Instead, I intend to comment on each in terms of its own merits.

I found the Series I package to be somewhat disappointing. While it has all the essentials for programming in assembly language, it really doesn't exploit the features of a disk-based system as fully as it could. The inability to use DOS commands such as DIR and KILL from within

the editor is particularly inconvenient. I also miss an in-memory assembly feature, which is a real time-saving tool. Nevertheless, when you consider the price, Series I is extremely attractive for the occasional user of assembly language. The documentation is excellent and the examples profuse. (However, users of the cassette-based system would do much better with Microsoft's EDTASM+, which supports macros and includes ZBUG, an excellent debugger. Best of all, the price is the same as that for the Series I cassette package.)

EDAS is rapidly becoming my favorite editor/assembler package. Although it does not support many advanced pseudo-operations and macro capabilities, it is nonetheless very powerful. It is very easy to use and, in my estimation, is the best choice for the beginning programmer who intends to seriously pursue assembly-language programming. The advanced programmer is by no means constrained by EDAS, however. With commands like \*GET and the conditional assembly, even the largest source files can be handled easily. The in-memory assembly greatly assists the programmer, as does the ability to use the DOS commands from the editor environment. The utilities which come with EDAS are also very useful. CMDFILE is particularly valuable for a great variety of tasks. The documentation for EDAS is excellent, though a summary of Z80 operations as found in the Series I package would be helpful. ■

**PRICE BREAK**

**EPSON  
MX-80  
CARTRIDGE RIBBONS**

**\$9.95**  
■ EA.

**\$107.46 per dozen**  
Minimum Order 3 Ribbons  
Price Includes Shipping  
We accept Mastercard and Visa

**CHECK-MATE™**  
P.O. BOX 103, RANDOLPH, MA 02368  
Call Toll Free - 1-800-343-7706  
In Massachusetts - 617-963-7694

Circle 536 on Inquiry card.

**CHECK US OUT!**

- ✓ **Product:** Continuous ten folded checks with dual window envelopes, checkbook binder and software designed especially for computer use in the home. You can't get continuous checks like these anywhere else in the world.
- ✓ **Savings:** Special package—including software—to get you started, 200 checks, 100 envelopes and binder - \$39.95. 500 checks, 300 envelopes and binder - \$79.95. Both with our versatile "Checkbook-Checkwriter II" program that will have you printing your checks the day you receive them.
- ✓ **GUARANTEE:** Our checks and accessories are guaranteed to please you and guaranteed compatible with your bank. In fact, if you order a special package and aren't satisfied for any reason, simply return it for a full refund (including postage) and you can keep the "Checkbook-Checkwriter II" program.
- ✓ **Bonus:**  
Each 850th customer—50% off your order  
Each 300th customer—Your order free  
Each 1000th customer—Your order free and free check refills for life

Order now. Or send for samples and info to:

**Synergetic Solutions**  
4715 SHEPHERD ROAD  
MULBERRY, FLORIDA 33860  
PHONE (813) 646-0557  
EMAIL: mch@NET 70970 936

Circle 535 on Inquiry card.

**PRICE BREAK**

**EPSON  
MX-100  
ZIP BOX REFILLS DESIGNED TO FIT  
EPSON MX-100 CARTRIDGE**

**\$9.95**  
■ EA.

**\$107.46 per dozen**  
Minimum Order 3 Ribbons  
Price Includes Shipping  
We accept Mastercard and Visa

**CHECK-MATE™**  
P.O. BOX 103, RANDOLPH, MA 02368  
Call Toll Free - 1-800-343-7706  
In Massachusetts - 617-963-7694

Circle 537 on Inquiry card.

## Getting the Most from Your TI Programmer

Robert L. Patton Jr, 1713 Parkcrest Terrace, Arlington, TX 76012

Enter number.  
  64    
 Write result as the initial digits of the answer.  
  64       
 Write result as the last 2 digits of the answer.  
 Note: You can use  8  in place of  64 and  8  in place of  64.

Figure 1: An algorithm for the TI Programmer which converts 7- or 8-digit hexadecimal integers to decimal numbers.

Enter last 2 digits (press  if negative).  
  
 Enter first  $n - 2$  digits (press  if negative).  
  64     
 Note: You can use  8  in place of  64.

Figure 2: An algorithm which will convert a 9- or 10-digit decimal integer to a hexadecimal number on the TI Programmer. The decimal integer may be in the range from -2147483648 to 2147483647.

Enter exponent.  
 If exponent is greater than 80 then  80  and remember that the final answer will be negative.  
 If current value is greater than 40 then  40   (For IBM 360/370 format, use this entry line regardless of the displayed value.)  
  1.20412   
 Note: If result is positive, the integer part is the base 10 exponent. Subtract from the result before continuing. If result is negative, the base 10 exponent is negative with a magnitude one greater than the integer part of the number displayed. Add the magnitude to the result before continuing.  
 3919  3404    
    42  98      
     20    
 40  1        1      
  
 Enter the 6 hexadecimal fraction digits.  
  256

This is the mantissa of the answer.

Figure 3: An algorithm which converts floating-point decimal numbers to hexadecimal numbers. It is assumed that the leftmost byte is the exponent, the three other bytes are the fraction, the high-order bit is the sign of the number, and the next to high-order bit is the sign of the exponent.

One of Texas Instruments' most unusual pocket calculators is called the Programmer. It does instantaneous arithmetic and base conversions in hexadecimal, octal and decimal. It also does logical functions in hex or octal.

Although it is a very handy instrument, you may run into difficulties if you are working with 4-byte arithmetic on your computer. You will not be able to convert 8-digit hexadecimal numbers to decimal because they overflow. Trying to convert a floating-point representation to its decimal equivalent seems impossible.

A solution is available. The keystroke algorithms shown here will let you make the conversion with a minimum of effort. ■

Convert floating-point E8765432 to decimal.

```

[HEX]
E8 [-] 80 [=] → 68 (final answer will be negative)
[-] 40 [=] [+/-] → FFFFFFFd8
[DEC] [X] 1.20412 [=] → -48.1648 (exponent will be -49) [+ ] 49
[X] 3919 [+ ] 3404 [=] [STO] → .96155958
[X] [K] [=] + 42 [-] 98 [-] [K] [=] [=] → 2.2830733
[X] [RCL] + [RCL] - 20 [X] [RCL]
+ 40 + 1 + [K] [=] [=] → 1.6803667
[X] [RCL] + 1 [X] [K] [=] [STO] → 6.8422664
[HEX] 765432
[DEC] [-] 256 [K] [=] [=] [=] [X] [RCL] [=] → 3.1626475
Final answer is -3.16265 × 10-48 (to 6 digits).

```

Figure 4: An example showing use of the algorithm in figure 3.

```
[SUM] [-] [RCL] [=] [SUM] [+/-]
```

Figure 5: A short algorithm which will exchange the display and memory contents (provided the result does not cause overflow). This algorithm can be used with any memory calculator which has SUM and M+ keys.

## RISK FREE MAIL ORDER

**IBM & OSBORNE**

PERSONAL COMPUTER  
CALL FOR PRICE & AVAILABILITY

### NEC PC-8000

PC-8001A 32K W/24K ROM  
5 FUNC. KEYS ..... 735  
PC-8012A I/O & EXPANSION  
SLOTS W/32K ..... 475  
PC-8031A DUAL DRIVES ..... 735  
BENCHMARK WORD PROCESSOR 379  
WORDSTAR ..... 299

### Apple II SOFTWARE & ACCESSORIES

VISICALC ..... 189  
VISIREND/VISIPLOT ..... 210  
VISIFILE ..... 199  
BPI BUSINESS SOFTWARE ..... 335  
WORDSTAR ..... 299  
HAYES MICROMODEM II ..... 299  
NOVATION CAT II ..... 349  
MICROSOFT Z-80 SOFTCARD ..... 299  
VIDEX 80 COLUMN CARD ..... 269

### DISKETTES

BASF 5 1/4" SS/DD/HUB RING (10) ... 23  
BASF 8" DISKETTES (10) ..... 24

TO ORDER. Please send cashier's check or personal check (allow 10 business days to clear). VISA and Master Card credit card service add 3%. Shipping, handling and insurance in U.S. add 3%. Minimum \$3.00. California residents add 6% sales tax. Foreign orders add 10% for shipping. Equipment is subject to price change and availability. All equipment carries warranty. Store prices may differ from mail order prices.

**computer age**

4688 CONVOY STREET, SAN DIEGO, CA 92111  
(800) 854-1941 (714) 565-7092  
CALL OR WRITE FOR COMPLETE PRICE LIST

### ATARI 800 & 400

ATARI 800 (16K) ..... 675  
ATARI 400 (16K) ..... 335  
410 PROGRAM RECORDER ..... 85  
810 DISK DRIVE ..... 499  
16K RAM MEMORY MODULE ..... 89  
850 INTERFACE MODULE ..... 165  
830 ACOUSTIC MODEM ..... 159  
ATARI VISICALC ..... 199  
ATARI WORD PROCESSOR ..... 125

### PRINTERS Epson

EPSON MX-80 ..... CALL  
EPSON MX-80FT ..... CALL  
EPSON MX-100 ..... CALL  
NEC 8023 FRICTION/TRACTOR ..... 499  
NEC 3530 SPINWRITER ..... 1950  
THE GRAPPLER INTERFACE ..... 129  
OKIDATA MICROLINE 82A ..... 575  
OKIDATA MICROLINE 83A ..... 795  
C.I.TOH STARWRITER F10-40PU ..... 1550  
C.I.TOH PROWRITER 8510 AP ..... 499

### MONITORS

AMDEX LOW-RES 13" COLOR I ..... 365  
AMDEX HI-RES 13" COLOR II ..... 850  
SANYO 9" B&W ..... 185  
ZENITH 12" GREEN (ZVM-121) ..... 129  
NEC 12" GREEN (JB-1201) ..... 169  
NEC 12" RGB COLOR (JC-1202DH) 875  
ELECTROHOME 13" RGB HI-RES ..... 825

WHEN

# SORTING

IT IS BETTER TO CO-SORT

CO-SORT IS DESIGNED TO RUN WITH YOUR CP/M PROGRAM SO THAT IT CAN RESPOND EASILY TO DYNAMIC REQUIREMENTS AND YOUR DEVELOPMENT IS EASY AND ACCURATE.

CO-SORT is a general-purpose high-speed sort/merge co-routine for all CP/M based applications. The routine is accessible from all languages, with any number of sources, variable or fixed length records, all data types and any number of keys in any direction. Best of all, your program won't have to stop to sort. In short, CO-SORT is the ultimate sort.

Priced at \$200, this program is well documented. For information, or to order, write INFORMATION RESOURCES, Box W, Manhasset, N.Y. 11030.

CP/M is a trademark of Digital Research.  
CO-SORT is a trademark of Information Resources.

**INFORMATION RESOURCES**  
BOX W, MANHASSET, NEW YORK 11030 (516) 365-7629

# Powerful... because it's Relational

The new RL-1 Database® from ABW Corporation gives you the power of a sophisticated relational database management system for your IBM Personal Computer\*, Cromemco\*, or CP/M\* computer.

## Why a Data Base Management System?

Whether your business is accounting, engineering, or production your main use of a computer is to maintain and process information. A Data Base Management System allows that information to be maintained independent of a particular application. Different programs can easily process the same data without modification or data re-entry.

## Why Relational?

The relational model presents data in simple, easy to use tables. The simplicity and power of this tabular form allows the user to answer complicated questions by learning only three operations: Selection, Projection, and Join.

## The RL-1 System Includes:

### Relational Data Base

A complete implementation of a relational data base.

### Query Language

An interactive high level query language, similar to SQL. This query language uses simple English phrases for the operations selection, projection, and join. Thus, even the novice user can easily ask sophisticated questions.

### Relational Editor

A screen oriented editor to create, delete, and update your data files.

### Program Interface

Allows you to access the data base through high level language programs.

### File Transfer Programs

Utility programs to assist the user in transferring to/from existing programs and other machines.

These five packages allow you to create and maintain a sophisticated data base system for many diverse applications.

## Application Packs

To assist the user several application packages will soon be available for use with the RL-1 system.

### Report Generator

Automatically formats data from multiple files for report generation.

### Input Processor

Allows user to input data via custom designed "forms" for easy operator entry.

### General Ledger

Includes General Journal, Posting to Accounts, Trial Balance, Balance Sheet, and Income Statement.

### Accounts Receivable

Generates invoices and statements. Handles aging of accounts receivable.

### Accounts Payable

Handles checks, check register, vouchers, and vendor files.

### Payroll

Processes 940, 941, and W-2 forms. Maintains employee files and payroll register.

### Inventory and Production Control

Maintains inventory status and current price lists. Generates reorder report, bill of materials, etc.

### Executive Planner

Assists in the generation of business plans and projections. Allows for optimization of key parameters.

### Graphics Processor

Allows data to be displayed graphically. Compatible drivers for the IBM Personal Computer, Cromemco SDI, Tektronix\* 4010, Houston Instruments DMP\* plotters, and many others.

RL-1 is available for IBM DOS, Cromix, CDOS, and CP/M system for only \$495.† Application Packs at additional costs.

Copyright 1982 by ABW Corporation  
\*IBM Personal Computer is a registered trademark of International Business Machines  
SDI, Cromix, CDOS, and Cromemco are registered trademarks of Cromemco, Inc.  
CP/M is a registered trademark of Digital Research, Inc.  
Tektronix is a registered trademark of Tektronix, Inc.  
DMP is a registered trademark of Houston Instruments  
†Mfr.'s suggested retail price

**RL-1**<sup>®</sup>  
RELATIONAL DATA BASE

For further information contact:  
ABW Corporation  
P.O. Box M1047  
Ann Arbor, MI 48106  
(313) 971-9364

**ABW** CORPORATION



# What's New?

## SYSTEMS



### 16-Bit Computer from NEC

NEC Information Systems' Advanced Personal Computer (APC) uses the CP/M-86 operating system and is based on a 16-bit NEC-manufactured 8086-compatible microprocessor. Features include 128K of user memory expandable to 256K bytes, color or monochrome displays, up to 2 megabytes of 8-inch double-sided double-density thin-line floppy-disk storage, detached keyboard with 22 user-definable dual-mode function keys, user-definable character sets, and high-resolution 8 by 19 dot-matrix characters.

A wide variety of software for the APC has been announced, including Microsoft's MS-DOS operating system, Accounting Plus from Systems Plus, the Benchmark word processor and Mailing List Manager from Metasoft, and Chang Laboratories' Microplan. Hardware options include the NEC 7220 processor for

line-drawing graphics with a screen resolution of 640 by 475 pixels. The basic APC, which includes 128K bytes of RAM, one 8-inch drive, and a green-phosphor 80-character by 25-line 12-inch monitor, has a suggested retail price of \$3298. Complete details are available from NEC Information Systems Inc., 5 Millitia Dr., Lexington, MA 02173, (617) 862-3120. Circle 600 on inquiry card.



### Commodore Markets Business Computer Series

The B128 microcomputer is the vanguard of a

new series of business computers from Commodore Business Machines. It offers 128K bytes of RAM (random-access read/write memory) and 40K bytes of ROM (read-only memory). The 6509-based B128 is equipped with a tilt-and-swivel 80-column by 25-line green-phosphor display, a built-in dual 5¼-inch disk drive, and a detachable 94-key keyboard with numeric keypad, double-zero and clear keys, a double-sized enter key, 10 function keys, and editing and cursor-control keys. Both RS-232C and IEEE-488 interfaces are built into the B128, which also comes with a real-time clock and a three-voice, nine-octave music synthesizer chip. Other standard features include the BASIC 4.0 language, output ports for direct connection to external sound systems, and a cartridge slot for plug-in software.

Among the expansion capabilities is the ability to accommodate a maximum of 256K bytes of internal RAM with as much as 640K bytes externally. Optionally, the B128 can be outfitted with a Z80 processor board to provide CP/M compatibility. In addition, CP/M-86 and UCSD Pascal are available. The B128 costs \$1695. Further specifications are available from Commodore Business Machines Inc., Computer Systems Division, The Meadows, 487 Devon Park Dr., Wayne, PA 19087, (215) 687-9750. Circle 601 on inquiry card.



### Sanyo Unveils Desktop Computer

The MBC-1000 desktop computer from Sanyo Business Systems Corporation uses an 8-bit Z80 microprocessor and comes with 64K bytes of RAM (random-access read/write memory). It features a green-phosphor, high-impact display screen and a detachable keyboard complete with number pad, cursor-control keys, and five programmable-function keys. Its single 5¼-inch double-sided double-density floppy-disk drive can be augmented with three more drives, or it can handle up to four 8-inch double-sided double-density drives for a total storage capacity of 5.2 megabytes. Standard software includes the CP/M operating system, Sanyo BASIC, diagnostics, and utilities. The MBC-1000 will support all CP/M-compatible software and will run CBASIC, MBASIC, FORTRAN, COBOL, and FORTH programs when equipped with the appropriate interpreter or compiler. Additionally, the MBC-1000 can be used in the Corvus Omninet network.

Software options include a word processor and elec-

# What's New?

tronic spreadsheets. A hard disk is also available. The MBC-1000 has a suggested list price of \$1995. Further specifications can be obtained from Sanyo Business Systems Corp.,

Computer Division, 51 Joseph St., Moonachie, NJ 07074, (800) 526-7043; in New Jersey, (201) 440-9300. Circle 602 on inquiry card.



## Inexpensive Personal Computer from Cromemco

Cromemco's C-10 SP (Super Pak) personal computer is supplied with a 12-inch display, detachable keyboard, 5¼-inch disk drive with 390K bytes of storage, and three software packages. The C-10 SP features a 4-MHz Z80 microprocessor, 64K bytes of internal user-accessible RAM (random-access read/write memory), and 24K bytes of ROM (read-only memory). Its display produces 25 lines of 80 characters and has four character sets, including graphics, supplied in 4K bytes of ROM. Data communications capabilities consist of an RS-232C serial port, a parallel Centronics-type printer port, a serial printer interface, and the

ability to emulate many different terminals and data protocols. Supplied software includes a CP/M-compatible operating system, a word-processing program, a financial spreadsheet calculator, and 32K bytes of structured BASIC.

The CP-10 SP costs \$1785. Optionally, the CP-10 can be purchased without the disk drive and software for \$995, or it can be obtained with a letter-quality printer, a tilt-and-swivel ergonomic stand, and the software for \$2875. Full specifications are available from Cromemco Inc., 280 Bernardo Ave., Mountain View, CA 94043, (415) 964-7400. Circle 603 on inquiry card.



## Voyagers

Information Support Systems' Voyager II and III desktop microcomputers use 8085 microprocessors and have 64K bytes of RAM (random-access read/write memory). The Voyager II's dual floppy-disk drives provide 2 megabytes of storage, while a hard-disk subsystem gives the Voyager III 6 megabytes of storage. As CP/M-compatible systems, the Voyagers are supported by Information Support Systems' word processing, medical patient billing, and accounting packages. The accounting package features accounts payable and receivable, general ledger, inventory control, payroll and personnel, and job order-control capabilities.

The suggested price for the Voyager II is \$7745. The Voyager III costs \$9990. Both systems are distributed by Hollander Office Products, Suite B, 41 Duesenberg Dr., Thou-

sand Oaks, CA 91362, (800) 235-3524; in California, (805) 496-2533. Circle 604 on inquiry card.

## 16-Bit Personal Computer from Hitachi

Hitachi's 16-bit 8088-based Personal Computer comes with 128K bytes of RAM (random-access read/write memory), expandable to 384K bytes. The system features a display screen, a detachable keyboard, a built-in double-sided double-density floppy-disk drive, and interfaces for other monitors, Centronics-type printers, light pens, and RS-232C communication devices. The screen can display 80 by 25 or 40 by 25 formats using 15 colors or in monochrome, and a large-capacity video RAM provides 640-dot horizontal by 400-dot vertical

# What's New?

graphics resolution in eight colors. The ability to overlay text and graphics is also supplied. The Hitachi Personal Computer runs under Microsoft's MS-DOS operating system and is supplied with a BASIC interpreter.

Optional equipment available for the Hitachi Personal Computer includes an 8087 mathematics processor and Pascal, FORTRAN, COBOL, and assembler languages. For marketing and pricing information, contact Hitachi Sales Corp., The Hitachi Atago Building #15-12, Nishi-Shimbashi 2-chome, Minato-ku, Tokyo 105, Japan; tel: Tokyo (03) 502-2111; Telex: J24492, J22391, J24114.

Circle 605 on inquiry card.



## Low-Cost Desktop Systems

Datamac Computer Systems' 1200 Series of self-contained, portable desktop microcomputers are CP/M-compatible. Based on the Z80 processor, each system has 64K bytes of RAM (random-access

read/write memory), two RS-232C ports, a parallel port, display screen, and one or two 5¼-inch floppy-disk drives. Drive formats can be single- or double-sided, single- or double-density, or 96 tracks per inch. The series features simultaneous use of hard disk and 5¼- and 8-inch floppy disks, local networking and multiuser capabilities, intelligent terminal emulation, RAM memory expansion up to 320K bytes, multiple-disk formats, and remote diagnostics. Also provided are 12 programmable-function keys, up to 58K bytes of user memory under CP/M, and a Help key capability. Options include an EPROM (erasable programmable read-only memory) burner and a System Activity Monitor that lets you display or alter memory and registers, set breakpoints, and single-step through a program as it runs.

The basic Datamac 1200, excluding disk drives but with a disk controller, costs \$2650. The \$4195 Datamac 1255 has two 5¼-inch double-sided double-density floppy-disk drives, each with 409K bytes of storage. The Datamac 1265, which has two 5¼-inch double-sided 96-track-per-inch drives each capable of storing 788K bytes of data, has a suggested list price of \$4670. Full details on the 1200 Series are available from Datamac Computer Systems, 680 Almanor Ave., Sunnyvale, CA 94086, (408) 735-0323. Circle 606 on inquiry card.



## Portable Computer Handles Any Application

The M6000P portable computer lets users configure for virtually any application, according to Micro Source. The unit features 368K bytes of storage per 5¼-inch floppy-disk drive, a modular design using STD-bus boards with an 8-slot card cage that can be expanded to 12 slots, a 9-inch green-phosphor cathode-ray tube with an 80-character by 24-line display format, and a VT-100-style detachable keyboard. The M6000P uses the Z80 processor, but it's upgradable to 68000 operation by virtue of the STD bus. The M6000P can use single- and double-sided single- or double-density disks under the CP/M 2.2 operating system. A rear connector for an optional 8-inch disk drive is provided. Standard software includes the Superfile database manager and Micropro's Wordstar, Calcstar, Spellstar, and Mailmerge programs.

Optional equipment for the M6000P includes a 10-megabyte Winchester

hard disk, battery backup, printer, an 8-inch floppy-disk drive, add-on memory cards, and a 6809 card running Flex. Prices start at \$3900. Complete details are available from the Micro Source Inc., POB 319, New Lebanon, OH 45345, (513) 687-1395. Circle 607 on inquiry card.

## 16-Bit Supermicros

Molecular Computer now offers 16-bit processing power on its multiuser Supermicro 8 and Supermicro 32 systems. The 16-bit capability, which is based on the 8086 micro-processor from Intel with up to 1 megabyte of memory, will coexist in the same system with 8-bit Z80 processors running under the CP/M-compatible n/Star operating system. This arrangement lets each user have a dedicated 8-bit Z80 and 64K bytes of memory for CP/M-compatible applications, while the 16-bit CP/M-86-compatible capa-

# What's New?

bility gives all users a shared resource with more addressing space. The increase in addressing space means that large applications such as complex modeling, graphics, large spreadsheets, and statistical packages are possible. Other features of the 16-bit Supermicros include up to 1 megabyte of RAM (random-access read/write memory) in 256K-byte increments, an Intel 8089 I/O DMA (direct memory access) processor, an 8-MHz system clock, and

parity for error detection.

Options include error correction circuitry, the 8087 mathematics processor, and up to 128 megabytes of Winchester-disk storage. A 16-bit processor with 256K bytes of RAM for both Supermicro 8 and 32 costs \$2795. Each additional 256K-byte increment, up to 1 megabyte, costs \$1495. For complete details, contact Molecular Computer, 1841 Zanker Rd., San Jose, CA 95112, (408) 995-5440.

Circle 608 on inquiry card.

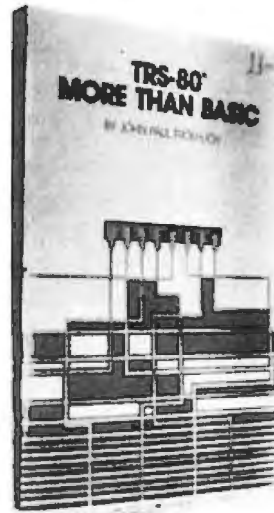

## TRS-80: More Than BASIC

The most recent addition to the Blacksburg Continuing Education Series, *TRS-80: More Than BASIC*, by John Paul Froehlich, shows you how to convert your TRS-80 Model I or III into a development system for programming in Z80 instruction-code mnemonics. It shows you how to convert the TRS-80 by loading object code from cassette or floppy disk or by replacing the BASIC ROM (read-only memory). It explains how you can obtain written text useful in tracing system development, and descriptions of the hardware for programming EPROMs (erasable programmable read-only memories) are provided. Appendices in *TRS-80: More than BASIC* furnish the command sequence table, references, a list of hardware and software suppliers, and source-code listing for the monitor program and for programming 2708, 2716, and 8755 EPROMs.

Available in softcover, the 220-page *TRS-80: More Than BASIC* costs \$10.95, plus \$1 shipping and handling. Order yours from Group Technology Ltd., POB 87, Check, VA 24072, (703) 651-3153. Circle 610 on inquiry card.

## Logical Database Design Explained

Logical Data Base Design by Robert M. Curtice and Paul E. Jones has all the information you need to develop a realistic working knowledge of effective logical database design, according to the publisher. Logical database design is organized as a set of rules and techniques within the bounds of a single methodological framework. Numerous illustrations and detailed descriptions of the problems and choices designers must face lead you beyond elementary principles and provide insight into the real issues encountered during the design process. Curtice and Jones supply extensive examinations of data elements, including the taxonomy of data, examples of elements that you're most likely to face, and a real database. The analysis of user requirements is covered, as well as the identification of entities and their representations, and the sorting out of relationships among entities. Other topics addressed include procedures for checking and preserving the integrity of logical data structure.

## PUBLICATIONS



## Carbonless Forms for Small Computers Detailed

A free eight-page color catalog detailing carbonless forms for small computers is available from the Delmart Company. The catalog presents a line of carbonless checks, invoices, and statements, plus a description of Delmart's custom-design service for variations in for-

mat, typefaces, and choice of different logos. Direct-mail prices for quantities as low as 500 are provided. Call or write Delmart Co., 530 North Wheeler St., POB 43495, St. Paul, MN 55164, (800) 328-9697; in Minnesota, call (612) 483-7888.

Circle 609 on inquiry card.

# What's New?

how to document a logical design, notational conventions, how to use the notation, fundamental rules of logical database design, and guidelines for logical design.

Logical Data Base Design is available for \$29.95 from Van Nostrand Reinhold, 135 West 50th St., New York, NY 10020, (212) 265-8700. Circle 611 on inquiry card.

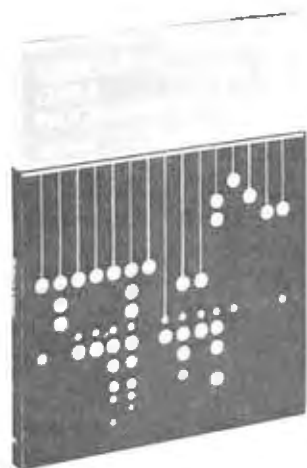

## Structured COBOL Programming

Structured COBOL Programming by Morris Pollack and Harry Geist can be used as a textbook in a one- or two-semester course or as a self-instruction guide. Its exercises provide you with practice in writing program segments, and its problems develop several programs, step-by-step, so that you can apply what you have learned in an orderly fashion. Each chapter is complemented by a concise outline of the concepts presented. Other features of Structured COBOL Programming include appendices covering

keypunching, BIM OS JCL, COBOL reserved words, and the Environment Division. A glossary of COBOL and computing terms, a selected bibliography, and an index supplement the text.

Structured COBOL Programming has a suggested list price of \$17.95. An accompanying instructor's guide costs \$3.33. Contact Bobbs-Merrill Educational Publishing, 4300 West 62nd St., POB 7080, Indianapolis, IN 46206. (317) 298-5400. Circle 612 on inquiry card.

## Newsletter Focuses on TCS Accounting Software

Rocky Mountain Software Systems produces a quarterly newsletter for users of the TCS (Technical Systems Consultants) accounting software system. TCS Debits and Credits has bug reports and fixes, potential enhancements to make the system more powerful or easier to use, new products and new version announcements, news on TCS-compatible products or services, and helpful ideas.

Subscriptions to TCS Debits and Credits are available to any TCS user for \$20 a year. A low-cost floppy-disk update service is available to subscribers. Contact Rocky Mountain Software Systems, POB 3282, Walnut Creek, CA 94598, (415) 625-1592. Circle 613 on inquiry card.

**ESP Electronic Specialists,**  
INTERFERENCE CONTROL &  
ELECTRONIC PRODUCTS CATALOG

PRODUCTS FOR  
MICROPROCESSORS • BUSINESS MACHINES • HOME TOOLS • CB  
LABORATORY INSTRUMENTS • AUDIO • TV • VTR

LINE CHECK monitor  
Page 27

ISOLATOR  
Pages 10, 15

LINE CORD SUPPRESSOR/FILTER  
Pages 11-16

PHONE INPUT FILTER  
Page 17

**ESP Electronic Specialists, Inc.**  
171 South Main Street, Natick, Mass. 01760  
(617) 655-1532

CATALOG 821

INDUSTRIAL • SCIENTIFIC • SHOPS  
FACTORIES • HOSPITALS  
LABORATORIES  
HOMES

## Electronic Products Catalog

Electronic Specialists has produced a 40-page catalog that presents its entire line of microcomputer interference-control cards. Also included are protective devices, line-voltage regulators, and AC power interrupters. Descriptive sections outlining particular

problems and suggested solutions are provided, and typical applications and uses are highlighted.

Request catalog 821 from Electronic Specialists Inc., 171 South Main St., POB 389, Natick, MA 01760, (617) 655-1532. Circle 614 on inquiry card.

## Magazine for Heath/Zenith Users

Sextant is an independent magazine designed for Heath/Zenith users. Its articles cover a wide variety of topics, including color graphics applications, advice on choosing programming languages, analyses of H/Z89 interface hard-

ware, software reviews, and game programs.

Annual subscriptions cost \$9.97 (four issues). Contact Sextant, 716 E St. SE, Washington, DC 20003, (202) 544-0900. Circle 615 on inquiry card.

# What's New?

## Quarterly Probes Voice Synthesis and Recognition

Speech Technology is a quarterly magazine devoted to the latest technical developments and applications in voice synthesis and speech recognition. Designed for engineers, scientists, educators, managers, and users, this journal probes all areas of speech-technology research from semiconductors to speech science. Other topics covered include digital sig-

nal processing, computer-processing architecture, and effective applications of human factors.

A year's subscription to Speech Technology costs \$50 in the U.S., \$58 in Canada and Mexico, and \$67 elsewhere. Speech Technology is published by Media Dimensions Inc., 525 East 82nd St., New York, NY 10028.

Circle 616 on inquiry card.

## Powertext for IBM

Beaman Porter's Powertext word-processing system for the IBM Personal Computer has sophisticated editing and comprehensive text-formatting capabilities. Automatic copy-placement styles include margins, indents, spacing, super- and subscripts, justification, centering, variable pitch, pagination, and table of contents. Complementing this are features such as form letters, automatic headers and footers, and unlimited documentation length. Other standard Powertext abilities include 132-character lines, vertical and horizontal border lines, boxed copy, print macro instructions, up to 14 columns, automatic footnote inclusion, and automatic title page, envelope, and labeling.

Powertext for the IBM Personal Computer is a run-time bootable system requiring a minimum of 64K bytes of memory, two disk drives, and a serial or parallel printer. It can accommodate 200K bytes per disk and, if your system has more than 64K bytes of memory, Powertext can provide extended memory for the program environment and RAM (random-access read/write memory) disk. Powertext costs \$399, including disk and a manual. The manual alone is \$25. Contact Beaman Porter Inc., Pleasant Ridge Rd., Harrison, NY 10528, (914) 967-3504. Circle 618 on inquiry card.

## H/Z89 Circuit-Analysis Program

Pressure Applications is marketing a circuit-analysis program for Heath/Zenith 89 computers. The program features steady-state circuit analysis of R-L-C elements, bipolar and junction FET transistors, and operational amplifiers. Its easy-to-use format and extensive function keys allow data files to be loaded and saved from disk. Also provided are element addition or deletion and listing to a printer functions.

The program, available for 5¼-inch hard-sectored disk only, requires the CP/M 2.2 operating system, MBASIC, and a minimum of 48K bytes of memory. It costs \$30. A version with screen-plotting capabilities sells for \$40. Order from Pressure Applications, 2478 Briarwood Dr., San Jose, CA 95125, (408) 269-6107.

Circle 619 on inquiry card.

## SOFTWARE



## FORTH CP/M and CDOS Cross-Compiler

Inner Access Corporation's 8080/Z80 MetaFORTH cross-compiler runs under CP/M or Cromemco's CDOS disk operating systems. MetaFORTH has both 8080 and Z80 assemblers and produces code that can be downloaded to any Z80- or 8080-based computer or put into ROM (read-only memory). It uses a built-in 79 Standard FORTH under CP/M or CDOS to create 79 FORTH code with an application on the target machine. Optionally, the target FORTH and applica-

tion can be written without headers and link words for space savings on the order of 25% to 30%.

MetaFORTH requires an 8080- or Z80-based system with 48K bytes of memory and CP/M or CDOS. It's available on a single-sided single-density 8-inch IBM-format floppy disk and on two 5¼-inch CDOS-format disks. The price is \$450. Contact Inner Access Corp., POB 888, Belmont, CA 94002, (415) 591-8295, for details. Circle 617 on inquiry card.

## Visischedule for the Apple III

Visicorp has released a more powerful version of its Visischedule interactive project-management program for the Apple III computer. The number of tasks that can be performed with this Visischedule are nearly double that of the Apple II version because of the Apple III's larger internal memory. A 128K-byte Apple III will support from 145 to 215 tasks per project, and a 256K-byte

# What's New?

Apple III will handle 300 tasks.

A minimum of 128K bytes of memory and an external disk drive are required. A printer is recom-

mended. The suggested retail price is \$300. Contact Visicorp, 2895 Zanker Rd., San Jose, CA 95134, (408) 946-9000.

Circle 620 on inquiry card.



## CP/M Applications Run Faster Under TurboDOS

TurboDOS, a Z80-based operating system, is a Software 2000 product said to be fully compatible with the CP/M 2.2 operating system, but three times as fast and capable of storing 25% to 35% more data on each disk. Available for single-user and networking configurations, TurboDOS supports hard disks to 1000 megabytes and features automatic file and record interlocks, high-performance print spooling, the ability to handle as many as 16 printers simultaneously, multiple commands per line, and nest-

ing of command files.

Software 2000 has designed versions of TurboDOS for the TRS-80 Model II, Xerox 820, Televideo TS-800, Digilog 1000 and 1500, IMS International 5000 and 8000 series, and most S-100 bus systems. An adaptable version for any Z80-based microcomputer can be obtained. Complete TurboDOS specifications will be furnished by Software 2000 Inc., 1127 Hetrick Ave., Arroyo Grande, CA 93420, (805) 489-1977.

Circle 621 on inquiry card.

## Flexible Programmer Tool

Digital Research's Access Manager programmer tool gives you a common method of data-access management for data files. Basically a general-purpose "keyed" file-access method, Access Manager lets you use meaningful key values, such as account number or customer name, to directly access data records on disk files. Indexes can be created to provide multiple keys to the database, regardless of which Digital Research compiler language you are using, through its link to the run-time system of application programs running under the CP/M or MP/M II operating system. Data will be accessible through programs incorporating Access Manager and written in PL/I-80, Pascal/MT+, or the CBASIC compiler, CB-80.

Access Manager has a suggested single-user price of \$300. Contact Digital Research, 160 Central Ave., Pacific Grove, CA 93950, (408) 649-3896, for full details.

Circle 622 on inquiry card.

## Easy-to-Use Real Estate Software

Simple Soft's Quikcalc Real Estate Investor is designed for prospective homeowners, real estate brokers, and investors. It has four separate files that can help evaluate potential

real estate sales or purchases. Basically a template for 64K-byte microcomputers using either Visicalc or Supercalc, Quikcalc is provided with separate models for individual residences and for income properties. Both models analyze purchase price, financing structure, tax implications, cash flow, and profitability after sale. All analyses are summarized into an inclusive internal rate of return.

Quikcalc has a suggested retail price of \$129.95. Versions are available for most popular computers, including the Apple and the IBM Personal Computer. Address inquiries to Simple Soft Inc., Suite 101, 480 Eagle Dr., Elk Grove, IL 60007, (312) 364-0752. Circle 623 on inquiry card.

## Milestone

Milestone is a project-management and time-scheduling program from Digital Marketing. It's written in Pascal and runs on CP/M, UCSD, and Apple Pascal systems. For CP/M systems, it is compiled using Pascal/M and is delivered, ready-to-run, with the Pascal/M run-time package. For UCSD Pascal systems, Milestone comes as an executable p-code file. Milestone will run on an 8086-based machine with CP/M-86, a Z80 system with Cromemco's CDOS operating system, an Apple II running Apple

# What's New?

Pascal or equipped with a Z80 softcard, a TRS-80 Model II running CP/M, and a Z80-, 8080-, or 8085-based machine running CP/M. Additional requirements include 56K bytes of RAM (random-access read/write memory), one disk drive, an 80-column printer, and a terminal with a 24-line by 80-column display, absolute cursor positioning, and a home-and-clear function.

Complete specifications are available from Digital Marketing, 2670 Cherry Lane, Walnut Creek, CA 94596, (415) 938-2880. Circle 624 on inquiry card.

## CBASIC-2 Screen Handler

Screenmaster from Marketing Essentials is a CBASIC-2 module in source-code form for inclusion in CBASIC-2 programs requiring screen input with automatic validation. CBASIC-2 code can be inserted to affect any degree of editing and control, overriding Screenmaster if necessary. Screenmaster provides such commands as GOTO (field) n, BACKWARD and FORWARD n fields, NEXT and PRIOR (screen), as well as SUBMIT and ABORT. Its output is an in-memory array of user responses for further use by the programmer. The Screenmaster disk includes utilities to test and create screens. Screenmaster can be used

with any dumb terminal.

Screenmaster is distributed on an 8-inch single-density CP/M-format disk; other formats are available. It costs \$195, the manual alone is \$25, and a demonstration disk can be purchased for \$10. Order Screenmaster from Marketing Essentials Inc., 206 Mosher Ave., Woodmere, NY 11598, (800) 645-2622; in New York, (516) 569-4533.

Circle 625 on inquiry card.

## Legend Slide Select

Legend Industries designed the Slide Select Program for use with its 64KC and 128KDE memory cards and the Apple II computer. The program, a combination of two pieces of software, lets you rapidly retrieve a high-resolution picture. One part of Slide Select is an Applesoft program that gives you control of high-resolution pictures. For the BASIC programmer, a machine-language interface is available for easy access to the Legend cards. Slide Select lets you flip back and forth between high-resolution pictures, resulting in the functional equivalent of a slide projector. Control over displayed pictures is user-selectable by means of the keyboard or game paddles, or it can be set to run automatically. Up to eight pictures can be stored in a 64KC card, and the 128KDE can store twice as much.

Slide Select comes stan-

dard when you purchase Legend 64KC or 128KDE memory cards, which cost \$349 and \$650, respectively. The program is also available as an \$8 update for users who already have Legend cards. Contact your local Apple dealer or Legend Industries Ltd., 2220 Scott Lake Rd., Pontiac, MI 48054, (313) 674-0953.

Circle 626 on inquiry card.

## Citation- Management Program

The maintenance of your personal reference file of scientific and academic citations from journals, books, and conference proceedings can be simplified with Bibliotek version 2.0 from Scientific Software Products. Bibliotek automates the process of bibliography management from citation entry through printing a finished reference list. Citation entry, modification, deletion, searching, sorting, and printing are controlled through prompted keyboard entries. Searches can be made by keyword, source title, author and editor, title phrases, and date in any combination. Equipped with extensive facilities for editing and altering responses, Bibliotek can store approximately 500 references in a single bibliography, which consists of two disks.

Bibliotek version 2.0 requires an Apple II computer with 48K bytes of RAM

(random-access read/write memory), Applesoft BASIC, two disk drives, and a printer. A single-user license costs \$300, including an extensive reference manual. The manual alone is \$25. Full details are available from Scientific Software Products Inc., 3171 Donald Ave., Indianapolis, IN 46224, (317) 299-0467. Circle 627 on inquiry card.

## PERIPHERALS



## Color Display

The ECM-1301 from Electrohome Limited is a 13-inch general-purpose color display monitor. The ECM-1301 has six user controls and is directly compatible with the IBM Personal Computer. The ECM-1301 provides a broad bandwidth, and it has separate modules for connection to other computers, including 8- and 16-color modules and an RS-170 module for separate red-green-blue inputs.

The EMC-1301 comes in both medium- (580 by 235 pixels) and high-resolution (720 by 512 pixels) versions. It is FCC Class A approved. For details, contact Electrohome Ltd., 809 Wellington St. N, Kitchener, Ontario N2G 4J6, Canada.

Circle 628 on inquiry card.



# What's New?



## Portable Communications System for the Disabled

Omni is a portable communications system for nonvocal, vocally impaired, or dexterity impaired individuals from Communications Research Corporation. A complete Omni system includes a display board, an LCD (liquid-crystal display) read-out, hard-copy printout facility, 16K bytes of programmable memory, a remote environment control, audible alarm, typewriter interface, and computer access. With the Omni system, disabled individuals can switch lights and electrical equipment on and off, summon an attendant, and select messages in the form of printed words, phrases, symbols, or pictures. Omni is equipped with an RS-232C port that provides interface capabilities with computers. The system also can substitute for the computer's keyboard, which provides access to programming and data input. Its reader/printer attachment provides alphabetic interpretation of symbols or pictures.

The Omni System ranges

in price from \$1275 to \$2975. For a brochure detailing optional equipment and ordering information, contact Communications Research Corp., 1720 130th Ave. NE, Bellevue, WA 98005, (800) 426-8075; in Alaska, Hawaii, and Washington, call (206) 881-9550.

Circle 629 on inquiry card.

## VIC Timesharing with Printout

RVR Systems' MDM-1 is a modem driver module that plugs directly into the user port of the Commodore VIC-20. It's supplied with two serial ports for a modem and a printer and a terminal program that permits telephone line connections to large timesharing computers and computer networks, such as Dow Jones, The Source, and Compuserve. Additionally, the MDM-1 has two indicators that show transmissions to and from the VIC. All transmissions are simultaneously recorded on the VIC's screen and

the serial printer. An external power source is not required.

The MDM-1 is available for \$59, plus \$3 shipping. For details, contact RVR Systems, POB 265, Dewitt, NY 13214.

Circle 630 on inquiry card.

## Intelligent Interface

Warn Electronics' intelligent printer interface for use with daisy-wheel printers, such as Hy-type I and Qume, lets you download data from the computer in either serial or parallel form. The interface, which uses a Z80 processor, relieves the host computer from controlling the printer so that it can perform more useful tasks. Data is stored in a software FIFO (first-in/first-out) buffer, using a space-compression technique. Data input can be accomplished by either a Centronics-compatible parallel port or a simplified RS-232C port (transmit data and receive data only). The parallel input has a variety of handshaking signals, including busy, printer fault, paper out, and ribbon out. Standard features include 16K bytes of storage, switch-selectable serial port data rates from 50 bps (bits per second) to 19,200 bps in 16 common rates, and selectable stop bits and parity.

The intelligent printer interface is available in an assembled and tested version or as a bare board and operating software. Both versions can be ob-

tained with software allowing basic features such as a full 16K-byte buffer, setting of form length, and reprinting of buffer. Cabinets, front panels, cables, and a variety of PROMs (programmable read-only memories) are available. The price for the intelligent interface ranges from \$125 to \$525. Contact Warn Electronics Ltd., POB 526, Knightdale, NC 27545, (919) 266-9411. Circle 631 on inquiry card.

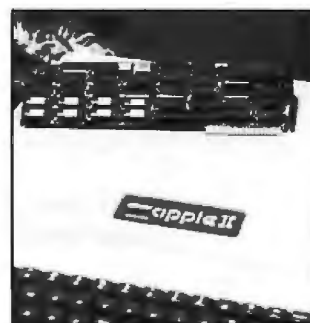

## Run IBM Programs on the Apple II

The 88Card from Coprocessors lets Apple II owners run programs designed for the IBM Personal Computer. The card contains a 5-MHz 16-bit Intel 8088 processor, 64K bytes of RAM (random-access read/write memory), and control functions. Users merely plug the card into a vacant slot in the Apple, turning it into a 16-bit personal computer with 128K bytes of memory. The card is fully compatible with Apple peripherals such as printers and disk drives. The 88Card has the ability to switch between normal Apple programs and IBM programs, using the IBM's

# What's New?

operating system. It operates from the Apple's internal power supply.

The 88Card costs \$899, including documentation. Further information is avail-

able from Coprocessors Inc., Suite 64, 50 West Brokaw Rd., San Jose, CA 95110, (408) 947-4616. Circle 632 on inquiry card.



## Low-Cost Printer Has Expensive Features

Integral Data Systems' Microprism produces fully-formed characters at 75 cps (characters per second) in a single pass of the print head. Standard features include a data mode for high-speed printouts at 110 cps, programmable character densities, an enhanced type mode, proportional and fixed spacing, automatic text justification, backspace and overstrike capabilities, and vertical and horizontal tabbing. Operator controls incorporate a fault and paper-out indicator and switches for power-up parameters, parallel or serial interfaces, and Xon/Xoff protocols. Dot-graphics features include 84 by 84 dots per inch resolution in a single pass, the ability to generate charts and drawings, and

bit-mapped architecture for control over the output.

Microprism is compatible with other Prism series printers. It has a suggested retail price of \$799 and can be ordered from Integral Data Systems, Milford, NH 03055, (603) 673-9100. Circle 633 on inquiry card.



## Apple II Hard-Disk Kit

A 5-megabyte Winchester hard-disk system kit for the Apple II computer is available from Xebec. According to the manufacturer, the kit can be assem-

bled in less than 10 minutes and does not require technical expertise. The kit consists of a 5¼-inch 5-megabyte Winchester-disk drive and Xebec's S-1410 intelligent disk controller. Standard features include up to 22-bit error detection, up to 11-bit error correction, a full-sector data buffer, and single-command disk initialization. Supplied with the system is an Apple II Host Adapter Personality Card that supports Apple DOS (disk operating system), the CP/M operating system, and the Pascal language; a 115/230-volt power module; cable set; cabinet; DOS or CP/M software; and installation instructions and documentation.

The 5-megabyte hard-disk system for the Apple II costs \$1299. Individual components can be purchased separately. Full specifications are available from Xebec, 432 Lakeside Dr., Sunnyvale, CA 94086, (800) 538-1644; in California, (800) 627-1842. Circle 634 on inquiry card.

## Omega 99G Printer from MPI

Micro Peripherals' Model 99G Omega is a bidirectional impact matrix printer. It can print on letterhead, bond paper, or multipart-cut forms because it has both a front-load, single-sheet feeder and a standard sprocket feed. With a maximum speed of 100

characters per second, the 99G can format printouts in 80-, 96-, or 136-column lines using a 7 by 9 dot matrix. High-quality printouts can be produced using an 11 by 9 matrix and a serif-style type font in an 80-column format. Double-wide characters are software-selectable from any of four print selections and can be intermixed on a line for message highlighting. Standard print features include full uppercase and lowercase ASCII (American Standard Code for Information Interchange) set, adjustable tractors for paper widths of 1 to 9 inches, 16 selectable forms lengths, skip-over perforation, user-selectable line spacing of 6 to 8 lines per inch, and a dot-addressable high-resolution graphics capability for plotting, printing of screen graphics, and generating special fonts, illustrations, and characters. Other standard features include a Centronics-type parallel interface, an RS-232C serial interface with Busy handshake and data rates ranging from 110 to 1200 bits per second, a 1K-byte buffer, and a continuous-loop ribbon cartridge.

A variety of options are available for the 99G, including a 2K-byte buffer, an IEEE-488 bus interface, and a 20-mA current loop. The 99G has a suggested retail price of \$849. Details can be obtained from Micro Peripherals Inc., 4426 South Century Dr., Salt Lake City, UT 84107, (801) 263-3081. Circle 635 on inquiry card.

# What's New?



## Universal Printer Buffer

Microfazer from Quadram Corporation is a universal printer buffer that can be used with most popular microcomputers and parallel printers. It uses standard Centronics signals and can draw its power from most printers. Data is received from the computer at rates of up to 4000 characters per second, and Microfazer is user-expandable from 8K bytes to 64K bytes using standard 64K-byte 200-nanosecond chips. It's designed to at-

tach directly to the input port of Epson and similar printers.

Microfazer is available in four models that offer buffering of 8K, 16K, 32K, and 64K bytes. Prices range from \$159 to \$299. Separate voltage power supplies are available where necessary. For complete details, contact Quadram Corp., 4357 Park Dr., Norcross, GA 30093, (404) 923-6666.

Circle 636 on inquiry card.

## MISCELLANEOUS

### Allenbach to Market OEM-quality Disks

Allenbach Industries, best known for its high-quality disk-duplication service, has set up a dealer network for its line of blank OEM- (original equipment manufacturer) quality floppy disks. Previously available only to software producers, the 5¼- and 8-inch disks can be purchased in single- or double-sided formats and double-density.

When Allenbach duplicates your software, each disk is copied and verified bit-by-bit. Guaranteed to

exceed ANSI (American National Standards Institute), ECMA (European Computer Manufacturers Association), and ISO (International Standards Organization) standards, Allenbach disks and duplication services carry lifetime warranties.

For complete details on the disks and disk-duplication services, contact Allenbach Industries, Suite A, 2101 Las Palmas, Carlsbad, CA 92008.

Circle 637 on inquiry card.



## Plug-In Power-Line Monitor

MCG Electronics' AC Line Transient Monitor will determine whether your AC line power contains transients and surges that could cause your computer to lose data or garble information. The Monitor has five LEDs (light-emitting diodes) that indicate power-on and that the line current has reached 200, 400, 600, and 800 volts or more. Also provided is a memory feature that retains transient data for 24 hours, even if the Monitor has been accidentally unplugged.

The Monitor fits into any standard 120-volt AC outlet and can be moved from outlet to outlet so that you can determine which is best. The Monitor is also helpful in determining whether a newly installed machine will cause damage before it has a chance to do so. The AC Line Transient Monitor costs \$189 and is available from MCG Electronics

Corp., 160 Brook Ave., Deer Park, NY 11729, (516) 586-5125.

Circle 638 on inquiry card.

## New Products from MPC

Apple II users can burn EPROMs (erasable programmable read-only memories) with MPC Peripherals Corporation's PROM-It EDS (EPROM Development System). The device can program 8K-, 16K-, and 32K-byte EPROMs such as the 2508, 2516, 2532, 2716, and 2732 with the change of a personality module. Its disk-based software helps you manipulate blocks, disk files, and EPROM code. Downloading hexadecimal files from any computer that's equipped with an RS-232C port is possible. Memory-mapped space permits execution of EPROM routines directly from PROM-It by means of the Apple's 6502 microprocessor. A switch-selectable write-protect feature ensures EPROM-code stability. PROM-It costs \$129.50.

Also available for the Apple II is an asynchronous serial I/O interface card, known as AP-SIO. It has driver firmware that follows the Apple's peripheral card convention, which ensures compatibility with all present and future operating systems. Switch-selectable firmware options include automatic linefeed/no linefeed, strip incoming linefeeds, half- and full-duplex, lower-

# What's New?

case-to-uppercase conversion/no conversion, and crystal-controlled data rates from 50 to 19,200 bits per second. The AP-SIO costs \$129.50. For further specifications on these products, contact MPC Peripherals Corp., 9424 Chesapeake Dr., San Diego, CA 92123, (714) 278-0630.

Circle 639 on inquiry card.

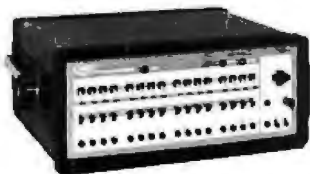

## High-Performance Logic Analyzer

Sage Enterprises' Model P1160 Logic Analyzer is a high-performance device designed for digital system testing and development. The 1160, nicknamed the Owl, is a 16-channel, 10-MHz logic analyzer that can be used with a standard dual-channel oscilloscope to obtain a 16-channel timing diagram display. When connected to a microcomputer, such as the Apple II, the Owl can provide video displays of timing diagrams, state tables in user-selectable binary, octal, or hexadecimal formats, and, with its Vector Graphic mode, an X,Y picture of digital information on the 16 channels.

The Owl costs \$950. For additional details, contact Sage Enterprises Inc., 1080 Linda Vista Ave., Mountain View, CA 94043, (415) 969-5111. Circle 640 on inquiry card.



## Minicassette Encode/Decode Circuit

Braemar Computer Devices is marketing an optional encode/decode circuit for its CM-600 Mini-Dek cassette drive. The data encode/decode capability eliminates the need for host hardware or software features to provide data timing and verification. Integral encoding/decoding also does away with costly engineering time that's required to interface the CM-600 to various digital applications.

The CM-600 uses minicassettes to record up to 90K bytes of data on a 50-foot cassette at a standard rate of 2400 bits per second. Power requirements are 1 watt at 5 volts DC. The encode/decode option adds \$25 to the CM-600's \$100 price tag. Complete details are available from Braemar Computer Devices, 11950 12th Ave. S, Burnsville, MN 55337, (612) 890-5135. Circle 641 on inquiry card.

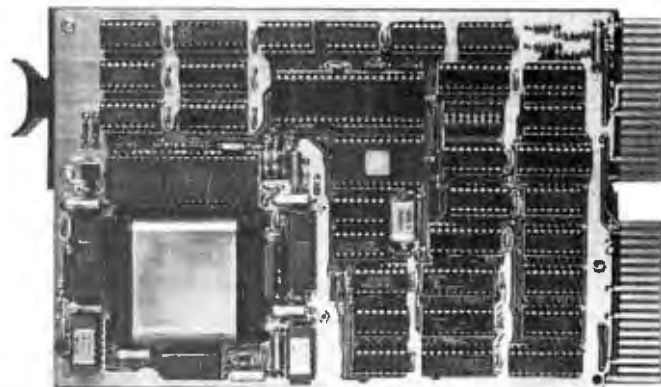

## Bubble Memory for LSI-11

Bubbl-Tec is marketing a single-board magnetic-bubble mass-storage memory system for DEC (Digital Equipment Corporation) LSI-11 computers. The QSB-11 Bubbl-Board is made up of a 1-megabit bubble device and a controller that emulates DEC's RX01 floppy-disk system. The controller handles bubble-device formatting and control, interfaces the bubble-memory system to the LSI's bus structure, and provides both soft- and hard-error protection and correction. Built on a dual-height LSI-11 module, the QSB-11 has 128K bytes of nonvolatile storage, an average access time to first data byte of less than 41

milliseconds, and data-transfer rates exceeding 68,000 bits per second. Power consumption is less than 15 watts, and only +5-volt and +12-volt power is required, both of which come directly from the LSI-11 bus.

The QSB-11 Bubbl-Board is fully compatible with all DEC LSI-11 systems, including the LSI-11/02 and -11/23, the SBC-11/21 Falcon, and the LSI-11/23 Plus. The price is \$1614, quantity ten; OEM (original equipment manufacturer) discounts are available. Contact Bubbl-Tec, 6800 Sierra Court, Dublin, CA 94566, (415) 829-8700.

Circle 642 on inquiry card.

## Where Do New Products Items Come From?

The information printed in the new products pages of BYTE is obtained from "new product" or "press release" copy sent by the promoters of new products. If in our judgment the information might be of interest to the personal computing experimenters and homebrewers who read BYTE, we print it in some form. We openly solicit releases and photos from manufacturers and suppliers to this marketplace. The information is printed more or less as a first-in first-out queue, subject to occasional priority modifications. While we would not knowingly print untrue or inaccurate data, or data from unreliable companies, our capacity to evaluate the products and companies appearing in the "What's New?" feature is necessarily limited. We therefore cannot be responsible for product quality or company performance.

### SPECIALS on INTEGRATED CIRCUITS

6502	7.45	10/6.95	50/6.55	100/6.15
6502A/6512A	8.40	10/7.95	50/7.35	100/6.90
6520 PIA	5.15	10/4.90	50/4.45	100/4.15
6522 VIA	6.45	10/6.10	50/5.75	100/5.45
6532	7.90	10/7.40	50/7.00	100/6.60
2114-L200		2.45	25/2.30	100/2.15
2114-L300		2.25	25/2.10	100/2.00
2716 EPROM		4.90	5/4.50	10/4.00
2532 EPROM		8.90	5/8.45	10/7.90
6116 Hitachi 2Kx8 CMOS RAM		8.90	5/8.45	10/7.90
4116-200 ns RAM				8 for 15
Zero Insertion Force 24 pin Socket				2.00
S-100 Wire Wrap Socket				2.40

**A P Products 15% OFF**  
**A P Hobby-Blox 15% OFF**

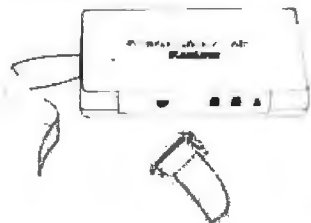

### MODEM SPECIAL \$89

**SIGNALMAN Mk1** from Anchor Automation DIRECT CONNECT Modem with RS232 Cable and Connector included. Fully compatible with all Bell 103 modems. 0 to 300 bps, full duplex, frequency shift keyed modulation, auto-select of ANSW/DIRG, direct connect, audible tone carrier detect indicator, self-contained battery powered.

<b>Anchor ATARI Modem</b>	<b>89</b>
<b>Anchor PET/CBM Modem</b>	<b>169</b>
<b>COMPACT Intelligent Terminal Package</b>	<b>115</b>
Combines intelligent RS232 port hardware from cgrs Microtech with EHS Intelligent Terminal software to allow you to connect any RS232 Modem to PET/CBM	
<b>DC HAYES Smartmodem</b>	<b>230</b>
<b>RS232 MODEM - Acoustic</b>	<b>119</b>

**We carry Apple II+ from Bell & Howell**

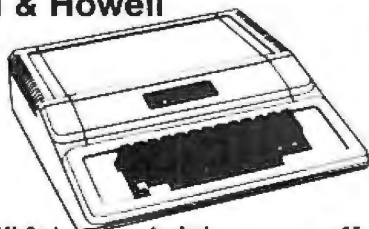

<b>16K RAM Card for Apple</b>	<b>65</b>
Apple LOGO	150
Video Recorder Interface	545
Super Serial Card	149
Thunderclock Plus	119
Z80 Softcard and CP/M	295
Parallel Printer Interface/Cable	85
Integer BASIC Card	150
Gragpler Interface	139
Apple Paddle Pair	29
<b>T G Products Joystick for Apple</b>	<b>48</b>
T G Paddles	32
DC Hayes Micromodem II	299
Videx 80 Column Card	259
FullFORTH+ for Apple (fig-Forth)	69
Stentype Printer and Card	310
Graphics Tablet and Card	645
Apple PASCAL Language	195
Apple FORTRAN	160
We stock EDUWARE Software	
GENIS I Courseware Development System	185
Unicom Grade Reporting	250
Unicom School Inventory (resource mgmt)	250
Executive Briefing System with fonts	225

## Commodore



**We stock the complete Commodore Line. Come see us for Personal, Business, and Educational requirements.**

**Educational Discounts available. Some used Commodore equipment available.**

### PETSCAN I \$345 base price.

Allows you to connect up to 20 CBM/PET Computers to shared disk drives and printers. Completely transparent to the user. Perfect for schools or multiple word processing configurations. Base configuration supports 3 computers.

VIC 20	239	VIC Superslot	24
VIC 1515 Printer	335	VIC Super Alien	24
VIC 3K RAM	32	Meteor Run (UMI)	39
VIC 8K RAM	53	VIC Radar Rptrace	24
VIC 16K RAM	99	Amok (UMI)	20
VIC 1540 Disk Drive	500	Snakman	13
VIC Avengers (Invaders) 24		Rubik's Cube	13
VIC Jupiter Lander	24	Programmers Reference	15
Spiders of Mars (UMI)	39	Renaissance (UMI)	39
<b>VICTORY Software for VIC</b>			
Street Sweepers	36	Maze in 3-D	12
Night Rider	11	Cosmic Debris	9
Treasurers of Bat Cave	17	Grave Robbers Adventure	11
Games Pack I	12	Games Pack II	12

TNW 488/103 with DAA	450
Compute's First Book of PET (CBM)	11
WordPro 3 Plus - 32K CBM, disk printer	195
WordPro 4 Plus - 8032 disk printer	300
VISICALC for PET ATARI or APPLE	190
<b>SM-KIT - PET ROM Utilities</b>	<b>40</b>
Programmers Toolkit - PET ROM Utilities	35
PET Spacemaker II ROM Switch	36
2 Meter PET to IEEE or IEEE to IEEE Cable	40
Dust Cover for PET	8
IEEE-Parallel Printer Interface for PET	110
IEEE-RS232 Printer Interface for PET	120
The PET Revealed	17
Library of PET Subroutines	12
SADI Intelligent IEEE-RS232 or parallel	235
<b>Programming the PET/CBM (Compute)</b>	<b>20</b>
Compute: First Book of VIC	11
<b>Best of Midnight Gazette</b>	<b>8</b>
<b>4 Part Harmony Music System for PET</b>	<b>60</b>

### FLEX-FILE for PET/CBM \$80

Very comprehensive and easily used DataBase, Report Writer with calculation capability and Mailing Label system.

<b>FORTH for PET by Cargile/Riley</b>	<b>\$50</b>
Full FIG model with all 79 Standard extensions.	
<b>Metacompiler for FORTH for independent object code</b>	<b>30</b>
<b>KMMM PASCAL for PET/CBM</b>	<b>85</b>
<b>EARL for PET/CBM - disk assembler</b>	<b>65</b>
Editor, Assembler, Relocator, Linkeditor	
<b>SuperGraphics - BASIC Language Extensions</b>	<b>40</b>
Fast Machine Language Graphics routines for PET/CBM	

## DISK SPECIALS



SCOTCH (3M) 5"	10/2.45	50/2.35	100/2.30
SCOTCH (3M) 8"	10/2.60	50/2.45	100/2.40

### WE STOCK VERBATIM DISKS

Try the new Verbatim Head Cleaner Kits

BASF 5" or 8"	10/2.00	20/1.95	100/1.85
Wabash 5"	10/1.80	50/1.75	100/1.70
Wabash 8"	10/2.25	50/2.20	100/2.10

### WE STOCK MAXELL DISKS

Diskette Storage Pages		10 for 3.95
Disk Library Cases	8" - 2.85	5" - 2.15
Disk Hub Rings	8" - 50 @ 7.50	5" - 50 @ 6.00

### CASSETTES - AGFA PE-611 PREMIUM

High output, low noise, 5 screw housings.

C-10	10/56	50/50	100/48
C-30	10/73	50/68	100/66

## SPECIALS

<b>EPSON MX-80 Printer with Grafltrax+</b>	<b>\$</b>
<b>EPSON MX-80 F/T Printer with Grafltrax+</b>	
<b>EPSON MX-100 Printer with Grafltrax+</b>	
Zenith ZVM-121 Green Phosphor Monitor	109
OKIDATA	465
STARWRITER Daisy Wheel Printer F10	1445
D C Hayes Smartmodem	230
<b>We Stock AMDEK Monitors</b>	
Watanabe Intelligent Plotter 990	6-Pen 1240
BMC BM12A Green Phosphor Monitor	85
<b>MEMORY for IBM 256K+ parity</b>	<b>500</b>
Staticide anti-static spray	6
dBASE II	445

### ALL BOOK and SOFTWARE PRICES DISCOUNTED

### Synertek Systems

<b>SYM-1 Microcomputer</b>	<b>SALE</b>	<b>189</b>
SYM BAS-1 BASIC or RAE 1/2 Assembler		85
KTM-2/80 Synertek Video and Keyboard		349
KTM-3/80 Synertek Tubeless Terminal		385

## ZENITH data systems

Z90-80 64 K	2170
Z90-82 64K, 1 double dens drive	2395
Z67 10 Megabyte + Floppy Drive	4495
Z37 13 Megabyte Dual Floppy	1495
Z25 High Speed Printer	1195
Z19 Video Terminal (VT-52 compatible)	695
ZVM-121 Green Phosphor Monitor	109
All Zenith Software discounted	

<b>ZT-1 Intelligent Communications Terminal</b>	<b>550</b>
<b>Z100 16-bit/8-bit System</b>	<b>CALL</b>



## ATARI SPECIALS

800 Computer	675	Microsoft BASIC	72
400-16K	269	MISSILE COMMAND	29
810 Disk Drive	440	ASTERIODS	32
825 Printer	629	STAR RAIDERS	37
850 Interface	170	Space Invaders	32
Inside Atan DOS	18	Music Composer	45
Paddle Pair	19	Chess	30
Joystick Pair	19	Anchor Modem-Atari	89
16K RAM	69	PAC-MAN	36
32K RAM	99	CENTIPED	36
Photo	68	First Book of Atan	11

Write for prices on other Atari items

### WRITE FOR CATALOG

Add \$1.25 per order for shipping. We pay balance of UPS surface charges on all prepaid orders. Prices listed are on cash discount basis. Regular prices slightly higher. Prices subject to change.

252 Bethlehem Pike  
Colmar, PA 18915

215-822-7727

## A B Computers

**\* ADDS \***

VIEWPOINT TERMINALS

**\$495**

In addition EPI carries printers DEC & DG compatible terminals and modems. Items in stock are shipped within 24 hours. ALL orders shipped COD. All items are new and in factory cartons with manufacturers warranties.

**ECONOMY PERIPHERALS INC.**

(404) 952-0213

Circle 176 on inquiry card.

**ANALOG ↔ DIGITAL  
DIGITAL ↔ ANALOG**

CONVERSION MODULES

**SOFTWARE GAIN CONTROL**

high accuracy — programmable gain instrumentation amplifier — custom board test — \$100 — 2 to 15 kHz conversion time — mixable high and low inputs — gain from 1 to 1024 — 12-bit — sample and hold amplifier 8 channel differential — 16 channel — analog to digital high accuracy — programmable gain instrumentation amplifier — custom board test — \$100 — 2 to 15 kHz conversion time — mixable high and low inputs — gain from 1 to 1024 — 12-bit — sample and hold amplifier 8 channel differential — 16 channel — analog to digital high accuracy — programmable gain instrumentation amplifier — custom board test — \$100 — 2 to 15 kHz

For additional details about the AD-100-A and other fine California Data Corporation 100% individually tested, high reliability products, circle the reader service card number below or for faster response write or call us

**CALIFORNIA DATA CORPORATION**

3475 Old Conejo Road, Suite C-10  
Newbury Park, CA 91320

(805) 498-3651

Circle 75 on inquiry card.

**Diagnostics and Treatment**

for your

**CP/M\* Computer**

TINYDOC™.....29.95 p.p.  
(8 7/8" 5 1/4" CP/M Disk)

Tests and diagnoses I/O, Memory, Disk-System, CPU; reads file parameters and mends files under software control, pinpoint bad chips, etc. (1 3/4 disk, specify)

**MICRO SERVICE GUIDE I**

"CP/M Computer System Servicing".....7.95 p.p.

**MICRO SERVICE GUIDE II**

"SA800/801 Disk Drive Servicing".....9.95 p.p.

MICRO SERVICE GUIDE books are written for anyone with basic electronic knowledge and ability to use screwdrivers. The appendix provides detailed repair techniques for people with soldering iron and an oscilloscope.

US Funds only. Foreign orders add \$8.00 Personal checks take 3-4 weeks. California residents add 6% tax. All orders are confirmed by mail. Write for technical details.

**R. F. & ASSOCIATES**

1930 Purdue Ave.  
Los Angeles, California 90025  
(213) 477-8310

\*Trademark of Digital Research

Circle 201 on inquiry card.

**Design Line  
Micro Work  
Stations**



RETAIL PRICE  
**\$185**

- A complete range of work stations designed specifically to house all micro-computers.
- Delivered heavily packed, in self-assembly form needing only a Phillips screwdriver and a few minutes of your time to assemble.
- Manufactured from 1" all wood particle board surfaced with hard-wearing melamine veneer, in either Oak or Walnut.
- Dealer and Distribution prices on request.
- For more information on our full range of work stations write or call 301-223-8900.

**ATLANTIC CABINET CORPORATION**  
P O Box 100, Wiltamport, Maryland 21785

Circle 41 on inquiry card.

**\$GOLD DISK\$  
CP/M® Compatible**

**Z-80 Software**

**Z-80 DISASSEMBLER**

An easy to use program to create source (.ASM) files from executable (.COM) files **\$175**

**EZ-TEXT WORDPROCESSOR**  
EZ-TEXT will format your text file the way you want it **\$75**

5-8" SD/DD **PPD**

**Bower-Stewart & Associates**

POST OFFICE BOX 1389  
HAWTHORNE, CALIFORNIA 90250

**213-532-1237**

Trademark Digital Research

Circle 62 on inquiry card.

**Got a computer?**



**Get a Giltronix Selector Switch.**

Eliminate unplugging and re-plugging your CPU's, peripherals, and modems. Eliminate expensive duplication of interconnection hardware. Connect three components to Giltronix Selector Switch #SSAB. Then select your connection with a simple turn of the dial. Only \$79 in OEM quantities. Monitoring options available. Full 5 year warranty on all Giltronix units.

**SWITCH TO GILTRONIX.**

**GILTRONIX, INC.**  
UNIVERSAL INTERFACE PRODUCTS

870 San Antonio Ave., Palo Alto, CA 94303

Circle 207 on inquiry card.

**Maxell Floppy Disks**

The Mini-Disks  
with maximum quality.



Dealer inquiries invited. C.O.D's accepted. Call FREE (800) 235-4137

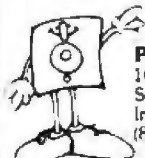

**PACIFIC EXCHANGES**  
100 Foothill Blvd., San Luis  
San Luis Obispo, CA 93401  
In Cal call (800) 592-5935 or  
(805) 543-1037

Circle 358 on inquiry card.

**NOT 5 MEGABYTES  
BUT 10 !!!  
\$-100 \$1995 APPLE  
TRS-80**

5 1/4" 10 MB HARD DISK DRIVE  
SMART CONTROLLER  
S-100, APPLE OR TRS-80  
COMPUTER INTERFACE  
POWER SUPPLY - ENCLOSURE - FAN  
ALL CABLING  
COMPLETELY ASSEMBLED  
AND TESTED

ASC WHO CURRENTLY RUNS  
ON THE FOLLOWING DISK  
OPERATING SYSTEMS: CP/M  
2.2, APPLE DOS, TRS-80  
LDOS

**LASC Associates**  
P.O. Box 615  
Lexington Park, MD 20653  
(301) 863-6784

LDOS is a trademark of Logical Systems Inc  
TRS-80 is a trademark of Tandy Corp.

Circle 37 on inquiry card.

**Build and Enhance**

your Apple \* software library at affordable prices. For the FIRST time — PACKED disks with 60 outstanding programs. Your Apple \* needs programs! At last you have an opportunity to use your Apple\* to its fullest capacity!

**APPLEWARE INC.** offers on each disk an extensive variety of programs including:

- |           |               |   |
|-----------|---------------|---|
| Business  | • Printer     | • Graphics  |
| Games     | • Text        | • Music   |
| Utilities | • Data Base   | • Finance   |
| Science   | • Engineering | • and many others with 3.3 DOS for easy demultiplying |

First 3 disks available at \$59.95 each  
Order all 3 for a free bonus disk.  
Call now toll free: 1-800-327-8664  
Fla. Residents: 305-584-7004  
Please add \$3 for postage & handling.

6400 Hayes St.  
Hollywood, FL 33024

\*TM Apple is a registered trademark of Apple Computer Co

Circle 31 on inquiry card.

# 40x24 VIDEO + 6502 MICROCOMPUTER

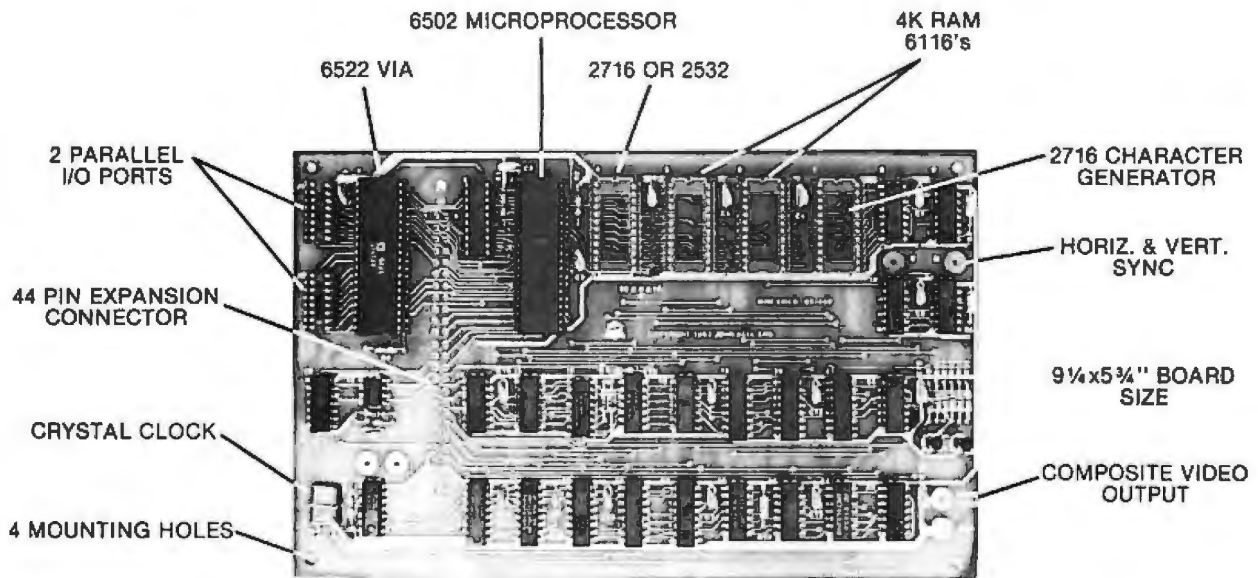

## "MINI VIDEO" 82-140

This board can be used to add a video display to your AIM or other computer. It can also, with the addition of a parallel keyboard, 5V power supply and video Monitor, be used as a home computer. It will run Tom Pittman's Tiny Basic. The 2716 character gen. will produce 256 8x8 characters, ASCII upper and lower case and graphic characters. The 44 pin expansion connector can be used to add up to 6K of memory or extra I/O ports.

Documentation includes schematic, parts list, connector pin outs, and source listing for video display and Monitor. Control character response: H-back space, I-up one line, J-line feed, L-clear screen and home, M-carriage return, U-forward space non destructive. The cursor is flashing underline type. Power requirements: 5 volts 600 MA 3 watts.

### Price:

Assembled video board without EPROMS #82-140A .....	\$149.95*
EPROM 2532 with Monitor + Tiny Basic .....	\$ 39.95*
EPROM 2716 character generator .....	\$ 19.95*
EPROM 2716 parallel input .....	\$ 19.95
Bare board with documentation #82-140B .....	\$ 79.95
*Three items if purchased together — save \$9.90 .....	\$199.95*



## JOHN BELL ENGINEERING, INC.

ALL PRODUCTS ARE AVAILABLE FROM JOHN BELL ENGINEERING, INC. • 1014 CENTER ST., SAN CARLOS, CA 94070  
ADD SALES TAX IN CALIFORNIA • ADD 5% SHIPPING & HANDLING 3% FOR ORDERS OVER \$100  
10% OUTSIDE U.S.A.

MC

SEND \$1.00 FOR CATALOG

(415) 592-8411

WILL CALL HOURS: 9am - 4pm

VISA

LOOK TO THE FUTURE...  
**EPROM-32**

The only EPROM programmer you need!

- IEEE-696 (S-100) EPROM programmer for single supply (+5V) EPROMs
- Programs current 1K through 16K (byte) EPROMs plus future 32K EPROMs
- EPROM can be verified through a port or located in memory space for verification and use.
- Personality Modules adapt board to different EPROM types  
PM-1 - 2508, 2758 PM-3 - 2732, 2732A PM-6 - 88764  
2516, 2716 PM-4 - 2664 PM-7 - 2528  
PM-2 - 2532 PM-5 - 2764 PM-8 - 27128
- Single zero-insertion-pressure socket accommodates both 24 pin and 28-pin EPROM packages
- On-board DC-to-DC converter with adjustable regulator for programming voltage.
- Double-sided PC board with solder masks, silkscreen and gold-plated contact fingers
- 8080/280 control software includes commands for programming, verification, disk I/O and editing.
- Comprehensive user's manual contains source listing of control software.

**MicroDynamics**

**\$269.95**  
(assembled & tested)

Corporation  
P.O. Box 17577  
Memphis, TN 38117  
(901)-755-0619

Price includes EPROM-32, documentation and two Personality Modules (specify). Additional Modules - \$7.95  
Control software on 6 inch single density CP/M-compatible diskette - \$9.95

MasterCard & Visa

TN residents add 8% sales tax.

Circle 318 on Inquiry card.

**NEW 23K  
PERSONAL  
COMPUTER**

**\$239<sup>00</sup>** FACTORY SALE PRICE

You get the NEW APF-IM-1 Full Size Powerful Computer: Includes 14K ROM with Level II BASIC built in, 8K User RAM, Color, Sound, Professional 53 keyboard, Two controllers, Two 10 key numeric pads, High speed cassette, A.C. adapter, RF modulator, T.V. switchbox. Accepts TAPE-DISK-PLUG IN CARTRIDGES. It is PLUG IN EXPANDABLE at low cost. 90 day parts and labor warranty, owners guide, BASIC language manual. All this in a beautiful black and white console case for only \$239<sup>00</sup>.  
**15 DAY FREE TRIAL** Return within 15 days complete and undamaged for refund of purchase price.

**PROTECTO ENTERPRISES**  
BOX 550, BARRINGTON, IL 60010  
TO ORDER PHONE 312/382-2192

Circle 385 on Inquiry card.

**FEEL TRAPPED  
BETWEEN  
CAPACITY AND  
COST?**

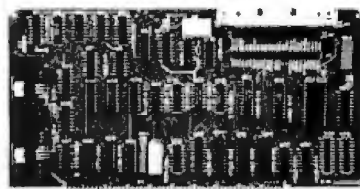

Processor interface introduces the Cartridge Disk Controller for the S-100 bus. Configurable for 12 sector 2315 and 5440 type disk drives (1.25 - 10 Mbytes per drive). Complete with CPM\* BIOS, disk formatter, diagnostics and technical manual. low cost \$595.00

Manual only \$25.00  
The performance you need at a cost you can afford



Processor Interfaces, Inc. P.O. Box 154A Elm Grove WI 53122  
414-785-1245

Circle 382 on Inquiry card.

**It's Now Available!  
The Light Pen For The  
IBM Personal  
Computer**



**Ideal For:** ■ Program Interface and menu selection. ■ Interactive graphics for engineering, business and CAD. ■ Very effective educational programs, without keyboard problems. ■ SUPER games, exciting demonstrations and just plain fun. **Professional Quality and Durable Construction, yet Inexpensive. Fully Supported Under IBM Basic for Color/ Graphics Adapter with Monochrome or Color Displays or TV's. (Not for use with IBM Monochrome Display).** Introductory Pricing: FT-156 Light Pen - \$159.95; Demo/Games Diskette - \$39.95. Call or write us, or see your participating IBM® dealer.

**FTG DATA SYSTEMS**  
10801 Dale Street, Suite M-2  
P.O. Box 615  
Stanton, California 90608  
(714) 995-3900 VISA & M/C Accepted

Circle 196 on Inquiry card.

**RGB Hi Resolution Color  
RGB Displays**

- High Contrast Black-White Tube
- Ultra Stable Components
- 15.7 Inch 16:9 Hi Spec
- Fast Demagnetization
- 100000 Hrs. Life
- 90 Day Warranty
- Aiming Targets

**13" - \$359<sup>00</sup>**  
\$119.95 + \$239.05 (incl. 40 lbs)

**19" - \$389<sup>00</sup>**  
\$119.95 + \$269.05 (incl. 40 lbs)

**IBM Cable - \$49<sup>00</sup>**  
\$119.95 (incl. 18' Cable)

**Bezels 13" - \$17<sup>00</sup>**

**19" - \$24<sup>00</sup>**

Note: Enclosed Models Now Available

**NEW! "Big Board Box" \$89<sup>95</sup>**

Alternative Enclosure for Floating Board  
Not Digital Research Computers And Ben  
Borrows

Accommodates Two full size 8" Flop, 8" 8040 Power Supply, Cooling Fan, "D" (13" or 19" serial peripheral CRT and multiple color displays and SBC boards in compatible color and interfacing box. Includes and Test (not incl. test, a set up kit)

**Dealin' Electronics**  
730 Loma Vista Pkwy. Altos, CA 94003  
415-951-9328

Dealers of  
OEM's - Call for  
multiple unit pricing.

Circle 153 on Inquiry card.

**PC/FORTH**

Complete FORTH program development systems for the IBM® Personal Computer. Packages include interpreter/compiler with virtual memory management, line editor, custom screen editor, assembler, decompiler, utilities, file and record access modules, and many demonstration programs. 100 page user manual... \$100.00

Floating point arithmetic extensions and cross compiler available at additional cost.

Ready to run under PC-DOS or CP/M-86® Standalone version available soon. 64 kbytes RAM and two disk drives recommended. (IBM is a registered trademark of International Business Machines Corp. CP/M is a registered trademark of Digital Research, Inc.)

**Laboratory Microsystems**  
4147 Brethren Street  
Los Angeles, CA 90066  
(213) 306-7412

Circle 282 on Inquiry card.

**BASF Flexy-Disks®**

**SAVE 40%** Write for our complete list.

**5 1/4" \*\* Specify soft.** Price/10  
10 or 16 sector

1 side/single density	.....	\$26.70
1 side/double density	.....	\$1.90
2 sides/double density	.....	\$37.10

**8" \*\* Specify soft**  
or 32 sector

1 side/single density	.....	\$26.70
1 side/double density	.....	\$31.90
2 sides/double density	.....	\$41.80

CHECKS - VISA - MC - C.O.D.  
(313) 777-7760 ADD \$2 SHIPPING

**LYBEN COMPUTER SYSTEMS**  
27204 Harper Ave.  
St. Clair Shores, MI 48081

Circle 273 on Inquiry card.

**p-System\* + CPR =  
Word Processing**

**CPR  
The Vital Link**

CPR is an advanced text formatter offering fast, flexible word processing for the UCSD p-System.

CPR functions include pagination, underlining, proportional spacing and a lot more.

CPR is available now on 8" diskettes for p-System versions II and IV including 175 page users' manual... \$199.00.

1988-1989 Edition - \$30.00

\* UCSD p-System™ is a trademark of the Regents of the University of California

**Chapin**  
ASSOCIATES

SOFTWARE FOR  
SYSTEMS AND  
APPLICATIONS

11568 Sorrento Valley Rd Suite 11 San Diego, CA 92121  
(714) 452-9340

Circle 83 on Inquiry card.

**C compilers  
and  
Cross compilers**

Available for:

PDP-11	RT-11/RX-11
6809	SDOS/FLEX
8080	CP/M
8085	CP/M
Z80	CP/M
8086	CP/M86
8088	MSDOS CP/M86

OTHERS PENDING

The full C language, as described in "The C Programming Language" by Kernighan and Ritchie.

UNIX version 7 compatible.  
Starting at \$200.00

UNIX is a trademark of Bell Labs. RT11, RSK11 are trademarks of Digital Equipment Corp. SDOS is a trademark of Software Dynamics. CP/M is a trademark of Digital Research. FLEX is a trademark of Technical Systems Computers

**TELECON SYSTEMS**  
90 E. Gish Road, Suite 25  
San Jose, California 95112  
408-275-1659

Circle 456 on Inquiry card.



# WE WILL NOT BE UNDERSOLD

## SOFTWARE

MICROPRO	
Wordstar	\$269.00
Mailmerge	89.00
Customization Notes	\$359.00
Spellstar	\$239.00
Datastar	\$199.00
Calccstar	\$199.00
MICROSOFT	
Basic Interpreter	\$349.00
Basic Compiler	\$389.00
Fortran 80	\$499.00
Cobol 80	\$695.00
DATA BASE	
FMS80	\$595.00
dBase II	\$599.00

## NEW! IBM PC SOFTWARE NEW!

INFORMATION UNLIMITED	
Easy Writer	\$289.00
Easy Speller	\$149.00
Easy Filer	\$319.00
VISICORP	
Visicalc 256K	\$190.00
VisiDex	\$199
VisiFile	\$229
VisiTrend/VisiPlot	\$229
MICROPRO	
Wordstar	\$299.00
MISCELLANEOUS	
Supercalc by Sorcim	\$229.00
Superwriter by Sorcim	\$289.00
Home Accountant Plus	\$139.00
ENTERTAINMENT	
Deadline	\$39.00
Temple of Apsah	\$29.00
Curse of Ra	\$15.99
Call For More IBM Software And Accessories	

## DISK DRIVES

CCI 100 for the TRS-80 Model 1	
5 1/4 40 track	\$299.00
CCI 189 for the Zenith Z-89	
5 1/4 40 track	\$379.00
CORVUS 5M with Mirror	\$3089.00
CORVUS 10M with Mirror	\$4489.00
CORVUS 20M with Mirror	\$5389.00
CORVUS Interfaces	CALL
RANA SYSTEMS add-on Disc Drive for the Apple II	
Elite One 40 Track	CALL
Elite Controller	CALL
Elite Two 80 Track	CALL
Elite Three 80 Track double-sided	CALL

## DISKETTES

Maxell 5 1/4 single side	\$39.00
Maxell 8 single side	\$49.00
Maxell 5 1/4 double side	\$45.00
Maxell 8 double side	\$55.00
BASF 5 1/4	\$28.95
BASF 8	\$38.00
Verbatim 5 1/4	\$26.95
Verbatim 8	\$36.00
Wabash 5 1/4	\$24.95
Wabash 8	\$29.95

## IBM PC ACCESSORIES

64K Card by Microsoft	\$435.00
Joystick by T & G	\$49.00
128K Card	\$579.00
192K Card	\$629.00
256K Card	\$899.00
Combo Card by Apparat	\$249.00
Call for more IBM PC add-ons	

For fast delivery, send certified checks, money orders, or call to arrange direct bank wire transfers. Personal or company checks require one to three weeks to clear. All prices are mail order only and are subject to change without notice. Call for shipping charges.

## APPLE SOFTWARE

MICROPRO	
Wordstar	\$269.00
MailMerge	\$99.00
Spellstar	\$149.00
DataStar	\$199.00
Calcstar	\$189.00
Supersort I	\$159.00
VISICORP	
VisiCalc	\$199.00
VisiTerm	\$79.00
VisiDex	\$189.00
VisiPlot	\$189.00
VisiFile	\$199.00
VisiSchedule	\$259.00
VisiTrend/Plot	\$239.00
VisiPac	\$539.00
MISCELLANEOUS	
Micro Courier	\$219.00
Screen Director	\$129.00
Executive Briefing System	\$169.00
Supercalc	\$99.00
Personal Filing System	\$115.00
PFS Report Writer	\$75.00
Word Handler	\$169.00
CP/M Power	\$59.00
ENTERTAINMENT	
Wizard and Princess	\$29.00
Twerps	\$28.00
Beer Run	\$28.00
Zork I, II	\$26.95
Deadline	\$39
Chop Lifter	\$24.95
Pinball	\$24.95
Cannonball Blitz	\$29.95
Knights of Diamonds	\$29.95
Midnight Magic	\$32.00
Wizardry	\$45.00
Time Zone	\$79.00
Tuesday Morning Quarterback	\$24.95
Crush, Crumble & Chomp	\$24.95
Dalestones of Ryn	\$15.99
Morloc's Tower	\$15.99
Star Warrior	\$31.99
Snack Attack	\$23.95
Star Blazer	\$24.95
Kabul Spy	\$29.95
Cyclod	\$23.95

## APPLE ACCESSORIES

ADVANCED LOGIC	
Add-Ram 18K Card	\$99.00
Z-Card CP/M for the Apple II	\$225.00
Smartem 80 Column Board w/Softswitch	\$249.00
The Synergizer	
All of the above plus "The CP/M Handbook"	\$545.00
Z-80 Card by Microsoft	\$319.00
16K Card by Microsoft	\$159.00
32K Card by Saturn	\$199.00
Keyboard Enhancer II by Videx	\$125.00
Videoterm by Videx	\$259.00
Game Paddles by TG	\$49.00
Joystick by TG	\$49.00
Numeric Keypad by Keyboard Co.	\$139.00
ALF 9 Voice Board	\$159.00
ALF 3 Voice Board	\$229.00
System Saver by Kensington	\$75.00
Versacard by Prometheus	\$229.00
8088 Card by Coprocessor	\$789.00
Microbuffer II 16K w/graphics	\$259.00
Microbuffer II 32K w/graphics	\$299.00
APPLE INTERFACE CARDS BY CCS	
Serial Asynch. #7710	\$139.00
Serial Synch. #7712	\$149.00
Call for other CCS cards	

## RAM

16K Ram Kit for Apple II; TRS80	\$17.50
200 nano seconds, 4115 chips	

## COMPUTERS

CALIFORNIA COMPUTER SYSTEM	
Mainframe 2200a	\$485.00
Z-80 CPU 2810a	\$265.00
64K RAM 2065	\$569.00
Floppy Controller 2422a	\$359.00
ZENITH	
Z-89 48K	CALL
Z-90 64K	CALL
Call For Prices On The Complete Zenith Line	
CASIO FX702P Pocket Computer	\$179.00
Sanyo MBC1000 64K	\$1649
Call For Prices On Complete Sanyo Computer Line	

## PRINTERS

NEC 7710 Serial	\$2395.00
NEC 7720 KSR	\$2749.00
NEC 7730 Parallel	\$2395.00
NEC 3510 Serial	\$1850.00
NEC 3530 Parallel	\$1850.00
NEC 8023 Dot Matrix 100cps	\$539.00
Olivetti DY211 Letter Quality	
Daisy Wheel Printer	\$1095.00
Parallel Only	\$995.00
Epson MX-80	CALL
Epson MX-80FT	CALL
Epson MX-100	CALL
IDS 560	CALL
IDS Prism 80	CALL
IDS Prism 132	CALL
Okidata Microline 80	CALL
Okidata Microline 82A	CALL
Okidata Microline 83A	CALL
Okidata Microline 84	CALL
Centronics 739	\$675.00
Datasouth 180 cps	CALL
Zenith Z-25 150 cps	CALL

## MONITORS

Amdex 12" B & W	\$109.00
Amdex 13" Color	\$329.00
Sayno 9" B&W	\$135.00
Sayno 9" Green	\$140.00
Sayno 12" B&W	\$179.00
Sayno 12" Green	\$189.00
Sayno 13" Color	\$359.00
Zenith 12" Green	\$99.00
Zenith 13" Color	\$339.00
Electrohome 13" HI-RES	
Color Monitor	\$829.00
Electrohome 13" Color	\$349.00
Electrohome 12" B&W	\$179.00
Electrohome 12" Green	\$189.00
Electrohome 9" B&W	\$149.00
Electrohome 9" Green	\$159.00

## SPECIAL OF THE MONTH

**RANA SYSTEMS**  
add-on disk drive for Apple II  
**Elite One 40 track** CALL

## TERMINALS

ADDS Viewpoint	\$495.00
Zenith Z-18	\$679.00
Televideo 910	\$595.00
Televideo 925	\$779.00
Televideo 950	\$969.00

## TELECOMMUNICATIONS

Prentice Star Modem	\$129.00
Novation Cat Modem	\$139.00
Novation D-CAT	\$149.00
Novation AUTO-CAT	\$189.00
Novation APPLE CAT	\$299.00
Hayes Smart Modem	\$249.00
Hayes Micro-Modem	\$295.00
Hayes Chronograph	\$225.00

# The CPU Shop

TO ORDER CALL TOLL FREE 1-800-343-6522

420-438 Rutherford Ave., Dept. B09M, Charlestown, Massachusetts 02129



Hours 9 AM - 9 PM (EST) Mon.-Fri. (Sat. till 6)  
Technical information call 617/242-3361

TWX- 710-348-1796

Massachusetts Residents call 617/242-3361  
Massachusetts Residents add 5% Sales Tax

Circle 135 on inquiry card.

BYTE September 1982 559

## 18086/8087/8088 CROSS SOFTWARE PACKAGES

**1** C cross compiler for the 8086. All facilities of the complete C language, including floating point for the 8087, are supported. Optionally, memory can be allocated for use with the 8088. Output is symbolic assembly language. The compiler is suitable for use in porting UNIX to the 8086.

**2** Cross assembler/linker/librarian/downline loader for the 8086. Assembler input is an extension to that used by Intel. Loader output is a file in standard Intel hex format.

**3** Simulator/debugger for the 8086. Capabilities include display, breakpoints, interpretive execution, as well as many others.

Most System: PDP-11 running RT-11, RSX-11M, UNIX/V6, UNIX/V7; or VAX-11 running VMS, UNIX/32V.

For additional information:



**Advanced**  
Digital Products, Inc.

1701 21st Ave. S., Suite 222 • Nashville, TN 37212  
Phone (615) 383-7520

Intel is a trademark of Intel Corporation. UNIX and UNIX/32V are trademarks of Bell Laboratories. RT-11, RSX-11M, PDP-11, VMS, and VAX-11 are trademarks of Digital Equipment Corporation.

Circle 11 on inquiry card.

## 5 1/4" DRIVES SUBSYSTEMS FOR APPLE\*, TRS-80\* & IBM\*



\* Reg. trademarks of Apple & Tandy Corp.

- DUAL 5 1/4" DRIVE ENCLOSURE...\$79.00  
(aluminum chassis, w/baked paint)
- POWER SUPPLY FOR THE ABOVE\$43.00  
(with switch & power card)
- CONVERSION KIT FOR 5 1/4" STD. DRIVE  
INTO APPLE DRIVE (with cable)...\$79.00
- CABLES FOR TRS-80 DRIVES ...\$35.00
- SINGLE SIDED 5 1/4" DR.(48TPI)...\$225.00
- 5 1/4" DRIVE REPAIR.....\$75.00  
(if beyond repair will replace for \$135.00)  
*Shipping & Handling add \$10.00*  
*California Residents add 6% Sales Tax*

**COMPUWARE PRODUCTS**  
4 Caraway • Irvine, CA 92714  
(714) 557-2190 • (714) 551-6324

Circle 125 on inquiry card.

## Pascal/MT+\* User!

Our Cross Module Identifier Checker traps mismatching declarations of global constant, type, and var identifiers, and routine headings made in different source files. Handles entire release 8.8 language, uses \$I, \$E, \$@, \$P compiler directives. Symbol table sizes are user modifiable. Comes with test data, documentation. \$99.00

## DBASE-2\* Vers 8.5B User!

Superb, user tested mailing list program. Last, First name, Street, City, State, Zip, 2 extra fields, < 160 bytes per record. Enter, edit data. Generates labels, reports, Wordstar\* form letters. User enterable record selection expression. Name, zip, append access orders. Comes with documentation, source code. \$99.00

## ATARI\* 400/800 memory!

16 KB RAM Board, A&T, \$ 75.00  
64 KB RAM Board, A&T \$199.00  
64 KB add-on RAM kit \$124.00

## Hald Products Inc.

86 Camille Ln., DBASE II TM ASHTON TATE  
E. Patchogue, Wordstar TM MICRO PRO  
NY 11772 ATARI TM ATARI Inc.  
(816) 889-9688 Pascal/MT+ TM Digital Research

Circle 212 on inquiry card.

## 64K Expansion Memory for

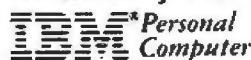

- ALL THE MEMORY YOU'LL EVER NEED
- Maximize Advanced BASIC Program Capacity
  - Increase VisiCalc\* Worksheet space to 4 times
  - Compile Pascal Programs

### RELIABLE PERFORMANCE THAT'S GUARANTEED

- Parity Generate and Check
- Gold Plated Edge Connector
- Fully Tested and Burned In
- Full One Year Warranty

INTRODUCTORY OFFER **\$175<sup>00</sup>**

DCT Corporation

P.O. BOX 14734  
MINNEAPOLIS, MN 55414-0734  
PHONE (612) 370-9235



\*IBM is a REGISTERED TRADEMARK OF IBM  
\*VISACALC is a REGISTERED TRADEMARK OF PERSONAL SOFTWARE, INC.

Circle 167 on inquiry card.

## Cables EIA RS 232-C

Quality cables with immediate  
delivery and low prices.

Conductor	Price
1-4	\$11.50 + .15/ft.
5-7	12.00 + .25/ft.
8-12	13.00 + .30/ft.
13-16	14.00 + .40/ft.
17-25	16.00 + .50/ft.

Specify: Male or female connectors, length of cable and pins to be connected. OEM & quantity discounts available to qualified customers. On prepaid orders add \$4.50 for shipping/handling

We also supply DEC  
and IBM Compatible cables.

## Communication Cable Company

319 Louella Ave. Wayne, PA 19087  
215-964-9404

Circle 95 on inquiry card.

## 18085 - Z80

### Structured Assembler

Get the benefits of high level programming with the efficiency of assembly language

#### Features:

PASCAL-LIKE STATEMENTS  
AUTOMATIC INDENTING  
RELOCATABLE ASSEMBLER  
LINKER GENERATED LISTINGS

#### Available for:

CP/M \$149  
TRS-80 \$149  
ISIS \$329

Specify disk size/density - CPU make/model  
Check - Money Order - Master Card - Visa

BLACKBEARD ASSOCIATES  
13534 PRESTON ROAD  
SUITE 443  
DALLAS, TX 75240  
(214) 255-9347

Circle 57 on inquiry card.

## AUTOMATE YOUR OFFICE WITH ASCII\* SOFTWARE CONTROLLABLE SWITCHES

\*TRADEMARK



- User selectable/software controllable
- Switches computers and peripherals
- User determined control words
- Supports 150 to 19200 baud
- Totally portable with AC option
- Features manual override operation

Advanced Systems Concepts, Inc.  
P.O. Box Q  
Alladena, California 91001  
(213) 684-5461 or 794-2308

Circle 13 on inquiry card.

## OMEGA

The Last Disassembler  
You Will Ever Need!

Mnemonics Externally Defined

Zilog, Intel, PASM Supplied

ASCII/HEX Preconditioner

Can Externally Def. Equates

Optional Address Listing

ASM/PASM/M80 Compatible

DB statements forcible over user  
specified range

\$150. complete/\$25. manual only  
for further information contact

**COMPUTER TOOLBOX, INC.**  
1325 East Main St.  
Waterbury, Ct. 06705  
Phone (203) 754-4197

## TYPESETTING from your own COMPUTER

Type your manuscripts, catalogs, or other text into your word processing computer.

Send it to us on a diskette or via a modem transmission and we'll send you camera ready film copy.

Computer typesetting provides high quality, easy to read copy at a fraction of the cost of conventional lypesetting.

Call or write for instructional brochure that includes typestyle selections, formatting instructions, and examples.

## Dream Electronics

131 N.W. 2nd. St. 1-503-7524833  
Corvallis, Oregon 97330

Circle 170 on inquiry card.

# FOR ONLY \$129.95 Learn Computing From The Ground Up

Build a Computer kit that grows with you, and can expand to 64K RAM, Microsoft BASIC, Text Editor/Assembler, Word Processor, Floppy Disks and more.

## EXPLORER/85

Here is the low cost way to learn the fundamentals of computing, the all-important basics you'll need more and more as you advance in computer skills. For just \$129.95 you get the award-winning Explorer/85 (from the millions who will buy and use the Explorer/85 this year alone). Four 8-bit plus one 6-bit input/output ports from which you can input and output your programs, as well as control exterior switches, lights, etc., a cassette interface that lets you store and retrieve programs you've learned to use, up to a 2,000 byte operating system/microprogram makes it easy to learn computing in several important ways. It allows simpler, faster writing and entering of programs. It permits access by you to all parts of the system so you can check on the status of any point in the program. It allows tracing each program step by step, with provision for displaying all the contents of the CPU (registers, flags, etc.) and it does much more!

You get all this in the starting level (Level A) of the Explorer/85 for only \$129.95. Increases! To use, just plug in your 4VDC power supply and terminal or keyboard/display — if you don't have them, see our special offers below.

Level A computer kit (Terminal Version) \$129.95 plus \$3 P&I\*  
 Level A kit (Hex Keypad/Display Version) \$129.95 plus \$3 P&I\*

**LEVEL B** — This "building block" converts the motherboard into a two-slot 5100 bus (industry standard) computer. Now you can plug in any of the hundreds of 5100 cards available.

Level B kit \$49.95 plus \$2 P&I\*  
 5100 bus connectors (two required) \$4.95 each, postpaid.

**LEVEL C** — Add still more computing power, this "building block" mounts directly on the motherboard and increases the 5100 bus to six slots.

Level C kit \$39.95 plus \$2 P&I\*  
 5100 bus connectors (five required) \$4.95 each, postpaid.

**LEVEL D** — When you reach the point in learning that requires more memory, we offer two choices: either add 16k of a memory directly on the motherboard or add 16k of 5100 memory by means of a single 5100 card. Our famous JAWS.

Level D kit (CHECK ONE)  4k on board \$49.95 plus \$2 P&I\*  
 16k 5100 JAWS \$149.95 plus \$2 P&I\*  
 32k 5100 JAWS \$199.95 plus \$2 P&I\*  
 48k 5100 JAWS \$249.95 plus \$2 P&I\*  
 64k 5100 JAWS \$299.95 plus \$2 P&I\*

**LEVEL E** — An important building block it activates the 48K/64K/96K special on the motherboard. Now just plug in our 8K Microsoft BASIC or your own custom programs.

Level E kit \$39.95 plus \$2 P&I\*  
 Microsoft BASIC — It's the language that allows you to write programs to your computer. It is available in two ways:  8K cassette version of Microsoft BASIC (requires Level B and 12k of RAM minimum, we suggest a 16k 5100 JAWS) — see above \$64.95 postpaid.  
 8K ROM version of Microsoft BASIC (requires Level B and 4k RAM and 4k RAM expansion to a 16k 5100 JAWS) \$99.95 plus \$2 P&I\*  
 Disk version of Microsoft BASIC (requires Level B, 32k of RAM, floppy disk controller, floppy disk drive) \$225 postpaid.

**TEXT EDITOR/ASSEMBLER** — The editor/assembler is a software tool program designed to simplify the task of writing programs. As your programs become longer and more complex, the assembler can save you many hours of programming time. This software includes an editor program that enters the programs you write, makes changes, and saves the programs on cassette. The assembler performs the tedious task of translating symbolic code into the computer-readable object code. The editor/assembler program is available either in cassette or a ROM version.

Editor/Assembler (Cassette version requires Level B and 8k (min.) of RAM, we suggest 16k JAWS) — see above \$69.95 plus \$2 P&I\*  
 Editor/Assembler (ROM version supplied on an 5100 card requires Level B and 4k RAM (min.) — we suggest either Level D or 16k JAWS) \$99.95 plus \$2 P&I\*

**FLOPPY DISK** — A remarkable "building block." Add our 8" floppy disk when you arrive. Easier operation, more convenient program storage, perhaps a business application and access to the literally thousands of programs and program languages available today. You simply plug them into your Explorer/85 disk system — it accepts all IBM formatted CP/M programs.

8" Floppy Disk Drive \$499.95 plus \$12 P&I\*  
 Floppy Controller Card \$199.95 plus \$2 P&I\*  
 Disk Drive Cabinet & Power Supply \$99.95 plus \$3 P&I\*

Drive Cabinet (set up for two drives) \$25.00 plus \$10 P&I\*  
 CP/M 2.2 Disk Operating System (includes Text Editor/Assembler, dynamic debugger and other features that give your Explorer/85 access to thousands of existing CP/M based programs) \$19.95 postpaid.

**NEED A POWER SUPPLY?** Consider our AP-1. It can supply all the power you need for a fully expanded Explorer/85 (note disk drives have their own power supply). Plus the AP-1 fits neatly into the attractive Explorer steel cabinet (see below).

AP-1 Power supply kit (RV #3 amp) in deluxe steel cabinet \$39.95 plus \$2 P&I\*

**NEED A TERMINAL?** We offer you choices the least expensive one is our Hex Keypad/Display kit that displays the information on a calculator-type screen. The other choice is our ASCII Keyboard/Computer Terminal kit that can be used with either



1. Plug in Netronics's Hex Keypad/Display
2. Add Level B to convert to 5100
3. Add 4k RAM
4. Plug in Level E (Hex or ASCII Keyboard/Display)
5. Add two 5100 boards
6. Add your own custom circuit (if printing necessary)
7. Connect terminal

a CRT monitor or a TV set (if you have an RF modulator)  
 Hex Keypad/Display kit \$99.95 plus \$2 P&I\*

**FASTERM-64 TERMINAL KIT** Featuring a 96 key ASCII Keyboard, 128 character set upper and lower case, 75 auto output, 8 baud rates, 150 to 19,200 baud rate, available: RS232C or 20 mA output, 32 or 64 character by 74 line format, complete with Deluxe Steel Cabinet and Power Supply \$199.95 plus \$3 P&I\*

**RF Modulator kit** (allows you to use your TV set as a monitor) \$6.95 postpaid

15" Video Monitor (10MHz bandwidth) \$139.95 plus \$5 P&I\*

Deluxe Steel Cabinet for the Explorer/85 \$49.95 plus \$3 P&I\*

Fan for cabinet \$15.00 plus \$1.50 P&I\*

### ORDER A SPECIAL-PRICE EXPLORER/85 PAK — THERE'S ONE FOR EVERY NEED.

**Beginner Pak** (Save \$20.00) — You get Level A (Terminal Version) with Monitor Source Listing (25¢ value), AP-1 5-amp power supply, Intel 8085 User Manual (Reg. \$199.95) SPECIAL \$189.95 plus \$4 P&I\*

**Experimenters Pak** (Save \$53.40) — You get Level A (Hex Keypad/Display Version) with Hex Keypad/Display Intel 8085 User Manual, Level A Hex Monitor Source Listing, and AP-1 5-amp power supply (Reg. \$279.95) SPECIAL \$219.95 plus \$6 P&I\*

**Special Microsoft BASIC Pak** (Save \$10.00) — You get Level A (Terminal Version), B, D, 14k RAM, A, 8k Microchip in ROM, Intel 8085 User Manual, Level A Hex Monitor Source Listing, and AP-1 5-amp power supply (Reg. \$429.95) SPECIAL \$329.95 plus \$7 P&I\*

**Add a Room-Version Text Editor/Assembler** (Requires Levels B and D or 5100 Memory) \$99.95 plus \$3 P&I\*

**Starter B" Disk System** — Includes Level A, B floppy disk controller, one CDD-8" disk-drive, two drive cable, two 5100 connectors, just add your own power supply, cabinet and hardware (Reg. \$1065.00) SPECIAL \$969.95 plus \$13 P&I\*  
 32k Starter System \$1049.95 plus \$13 P&I\*  
 48k Starter System \$1089.95 plus \$13 P&I\*  
 64k Starter System \$1169.95 plus \$13 P&I\*

**Add to any of above Explorer steel cabinet, AP-1 five amp power supply, Level C with two 5100 connectors, disk drive cabinet and power supply, two sub-D connectors for connecting your printer and terminal (Reg. \$225.95) SPECIAL \$199.95 plus \$11 P&I\***

**Complete 64K System (Printer & Terminal) \$1650.00 plus \$20 P&I\***  
 **Special Complete Business Software Pak** (Save \$625.00) — Includes CP/M 2.2 Microsoft BASIC (General Ledger, Accounts Receivable, Accounts Payable, Payroll Package) (Reg. \$1325) SPECIAL \$699.95 postpaid.

\*P&I stands for "postage & insurance." For Customers in Canada, double this amount.

Continental Credit Card Buyers Outside Connecticut:

**TO ORDER**  
**Call Toll Free:**  
**800-243-7428**

To Order From Connecticut, or For Technical Assistance, Call (203) 354-9375

CP/M is a reg. trademark of Digital Research

★ (Clip and mail entire ad) ★

SEND ME THE ITEMS CHECKED ABOVE

Total Enclosed (Conn. Residents add sales tax) \$ \_\_\_\_\_  
 Paid by:  Personal Check  Cashier's Check/Money Order

VISA  MASTER CARD (Bank No. \_\_\_\_\_)  
 Acct. No. \_\_\_\_\_ Exp. Date \_\_\_\_\_

Signature \_\_\_\_\_  
 Print Name \_\_\_\_\_

Address \_\_\_\_\_  
 City \_\_\_\_\_ State \_\_\_\_\_ Zip \_\_\_\_\_

State \_\_\_\_\_ Zip \_\_\_\_\_

NETRONICS Research & Development Ltd.

333 Litchfield Road, New Milford, CT 06776

# ANNOUNCING TWO NEW TERMINALS

Smart • Fast • Graphics • Matching Modem and \$295 Printer

Netronics announces a state of the art breakthrough in terminals. Now at prices you can afford, you can go on-line with data-bank and computer phone-line services. It's all yours: "electronic newspapers," educational services, Dow-Jones stock reports, games, recipes, personal computing with any level terminal boards... and more every day!!!



Netronics offers two new terminals, both featuring a full 56 key/128 character typewriter-style keyboard, baud rates to 19.2 kilobaud, a rugged steel cabinet and power supply. The simplest one, FASTERM-64, is a 16 line by 64 or 32 character per line unit, with a serial printer port for making hard copy of all incoming data, and optional provisions for block and special character graphics. The "smart" version, SMARTERM-80, features either 24 lines by 80 characters per line or 16 by 40 characters per line, it offers on-screen editing with page-at-a-time printing, 12,000 pixel graphics, line graphics, absolute cursor addressing, underlining, reverse video, one-half intensity and much more... simply plug them into your computer or our phone modem and be on-line instantly. Use your TV set (RF modulator required) or our deluxe green-phosphor monitor pictured above. For hard copy (just add our matched printer:

Price breakthrough!!! Own the FASTERM-64, a complete terminal kit, ready to plug in for just \$199.95 or order the SMARTERM-80 kit for just \$299.95. (both available wired and tested.) Be on-line with the million-dollar computers and data services today... we even supply the necessary subscription forms.

More good news. All the components in our terminals are available separately (see coupon), so you buy only what you need!!!

**FASTERM-64** ... DISPLAY FORMAT: 64 or 32 characters/line by 16 lines ... 96 displayable ASCII characters (upper & lower case) ... 8 baud rates: 150, 300, 600, 1200, 2400, 4800, 9600, 19,200, (switch sel.) ... LINE OUTPUT: RS232C or 20 ma current loop ... VIDEO OUTPUT: 1V p/p (EIA RS-170) ... CURSOR MODES: home & clear screen, erase to end of line, erase cursor line, cursor up & down, auto carriage return/line feed at end of line & auto scrolling. REVERSE VIDEO, BLINKING CURSOR, PARITY: off, even or odd ... STOP BITS: 1, 1.5, 2 ... DATA BITS PER CHARACTER: 5, 6, 7 or 8 ... CHARACTER OUTPUT: 5 by 7 dot matrix in a 7 by 12 cell ... PRINTER OUTPUT: prints all incoming data ... 1K ON BOARD RAM, 2K ON BOARD ROM, CRYSTAL CONTROLLED ... COMPLETE WITH POWER SUPPLY. OPTIONAL GRAPHICS MODE: includes 34 Greek & math characters plus 30 special graphics characters ... ASCII ENCODED KEYBOARD: 56 key/128 characters.

**SMARTERM-80** ... DISPLAY FORMAT: 80 characters by 24 lines or 40 characters by 16 lines 128 displayable ASCII characters (upper & lower case); 8 baud rates: 110, 300, 600, 1200, 2400, 4800, 9600, 19,200 ... LINE OUTPUT: RS232C or 20 ma current loop ... VIDEO OUTPUT: 1V p/p (EIA RS-170) ... EDITING FEATURES: insert/delete line, insert/delete character, forward/back tab, LINE OR PAGE TRANSMIT, PAGE PRINT FUNCTION, CURSOR POSITIONING: up, down, right, left, plus absolute cursor positioning with read back ... VISUAL ATTRIBUTES: underline, blink, reverse video, half intensity, & blank ... GRAPHICS: 12,000 pixel resolution block plus line graphics ... ON-SCREEN PARITY INDICATOR ... PARITY: off, even or odd ... STOP BITS: 110 baud 2, all others 1 ... CHAR. OUTPUT: 7 by 11 character in a 9 by 12 block ... PRINTER OUTPUT: 60 OR 50 Hz VERTICAL REFRESH, BLINKING BLOCK CURSOR, CRYSTAL CONTROLLED, 2K ON BOARD RAM ... ASCII ENCODED KEYBOARD: 56 key/128 character ... 4K ON BOARD ROM ... COMPLETE WITH POWER SUPPLY.

**TELEPHONE MODEM 103 OIA** ... FULL DUPLEX, FCC APPROVED ... DATA RATE: 300 baud direct connect phone, originate/answer switch on rear panel ... NO POWER SUPPLY REQUIRED.

**ASCII KEYBOARD ASCII-3** ... 56 KEY/128 CHARACTER ASCII ENCODED ... UPPER & LOWER CASE ... FULLY DEBOUNDED ... 2 KEY ROLLOVER ... POS OR NEG LOGIC WITH POS STROBE ... REQUIRES +5 & -12V DC (SUPPLIED FROM VIDEO BOARDS) ... PRINTER COMET I ... SERIAL (10 TO 9600 BAUD) ... 80 CHARACTER COLUMN (32 COMPRESSED) ... 10" TRACTOR FEED ... UPPER/LOWER CASE ... INDUSTRY STANDARD RIBBONS ... 4 CHARACTER SIZES ... 9 BY 7 DOT MATRIX ... BI-DIRECTIONAL PRINTING.



Continental U.S.A. Credit Card Buyers Outside Connecticut

**CALL TOLL FREE 800-243-7428**

To Order From Connecticut Or For Tech. Assist. Call (203) 354-9375

**NETRONICS R&D LTD. Dept.**  
 333 Litchfield Road, New Milford, CT 06776

Please send the items checked below:

**COMPLETE FASTERM-64 TERMINAL** (includes FASTVID-64 video board ASCII-3 keyboard, steel cabinet and power supply) ... kit \$199.95 plus \$3 P&I ... wired & tested \$249.95 plus \$3 P&I ... graphics option: add \$19.95 to each of above

**COMPLETE SMARTERM-80 TERMINAL** (includes SMARTVID-80 video board, ASCII-3 keyboard, steel cabinet and power supply) ... kit \$299.95 plus \$3 P&I ... wired and tested \$369.95 plus \$3 P&I

**FASTVID-64 VIDEO BOARD** (requires +5 & -12V DC) ... kit \$99.95 plus \$3 P&I ... graphics option add \$19.95 ... wired & tested \$129.95 plus \$3 P&I ... graphics option add \$19.95

**SMARTVID-80 VIDEO BOARD** (requires +5 & -12V DC) ... kit \$199.95 plus \$3 P&I ... wired & tested \$249.95 plus \$3 P&I

**DELUXE STEEL TERMINAL CABINET** ... \$19.95 plus \$3 P&I  
 **ASCII-3 KEYBOARD** (requires +5 & -12VDC) ... kit \$69.95 plus \$3 P&I ... wired and tested \$89.95 plus \$3 P&I  
 **POWER SUPPLY** (powers ASCII-3 keyboard & video boards) ... kit only \$19.95 plus \$2 P&I

**ZENITH VIDEO MONITOR** (high resolution green phosphor) ... wired & tested \$149.95 plus \$6 P&I  
 **TELEPHONE MODEM MODEL 103 OIA** ... wired & tested \$189.95 plus \$3 P&I

**DOT MATRIX PRINTER Comet I** ... wired & tested \$299.95 plus \$10 P&I  
 **RF MODULATOR MOD RF-1** ... kit only \$8.95 plus \$1 P&I  
 **3FT-25 LEAD MODEM/TERMINAL OR PRINTER/TERMINAL CONNECTOR CABLE** ... \$14.95 ea plus \$2 P&I

For Canadian orders, double the postage. Conn. res. add sales tax.

Total Enclosed \$ \_\_\_\_\_

Personal Check  Cashier's Check/Money Order

VISA  MasterCard (Bank No. \_\_\_\_\_)  
 Acct. No. \_\_\_\_\_ Exp. Date \_\_\_\_\_

Signature \_\_\_\_\_  
 Print Name \_\_\_\_\_  
 Address \_\_\_\_\_  
 City \_\_\_\_\_ State \_\_\_\_\_ Zip \_\_\_\_\_

**SINGLE BOARD CONTROL COMPUTERS.**

BOTH FEATURING  
8085 CPU  
CRYSTAL TIME BASE  
ON-BOARD REGULATOR

TIMER COUNTER  
256 BYTES OF RAM

**SPCS-1**  
★ Has 2K/1K ROM/EPROM (ROM's are not supplied),  
★ 16 I/O Lines (Parallel/Serial/Handshake) and  
★ 5 levels of interrupt. Price: \$129 (MSRP)

**SPCS-2**  
★ Has 2K ROM/EPROM (ROM's are not supplied),  
★ 22 I/O Lines - Parallel/Serial/Handshake and  
★ 2 levels of interrupt. Price: \$99

**CER-TEK**  
6020 Doniphan 38 El Paso, TX 79932 (915) 581-6697  
ELECTRONICS MANUFACTURING SINCE 1975

Circle 82 on inquiry card.

**NEED CP/M SOFTWARE? CONTINENTAL HAS IT!**

CP/M software is available now

For: Apple • Commodore CBM/PET • DEC RAINBOW • DEC VT180 • Health • Hewlett-Packard • IBM PC • NEC PC-8001 • Televideo • TRS-80 Model II • Wangwriter • Xerox 820

Applications: Accounting • Languages • Micro to Mainframe Communications • Office Aids • Spread Sheet/Financial Modeling • Word Processing

Send today for a free catalog or call toll-free 1-800-343-4688 (Mass. residents call 617-275-6563) Dealer inquiries invited.

**CONTINENTAL RESOURCES, INC.**  
175 MIDDLESEX TPK., BEDFORD, MA 01730

Circle 131 on inquiry card.

**Dyan CORPORATION**

Solve your disc problems, buy 100% surface tested Dyan diskettes. All orders shipped from stock, within 24 hours. Call toll FREE (800) 235-4137 for prices and information. Visa and MasterCard accepted.

**PACIFIC EXCHANGES**  
100 Foothill Blvd  
San Luis Obispo, CA  
93401 (In Cal call  
(805) 543-1037)

Circle 356 on inquiry card.

**IEEE-488**

GENERAL PURPOSE PARALLEL INTERFACE LINKS PRINTERS, TEST EQUIPMENT AND EXPERIMENTS TO THE IEEE-488 BUS

- CENTRONICS INTERFACE COMPATIBLE
- CONVERTS 488 PROTOCOL TO TTL I/O
- SUPPORTS ALL TALK LISTEN FUNCTIONS
- EIGHT POWER DRIVERS CONTROL DC LOADS
- PROGRAMMING EXAMPLES INCLUDED
- CABLES AVAILABLE FOR MOST APPLICATIONS
- PRICED FROM \$195 / \$15 FOR MANUAL ONLY

CALL OR WRITE FOR DETAILS

**SEITZ** SEITZ TECHNICAL PRODUCTS, INC.  
P.O. BOX 76 NEW LONDON, PA 16360  
PHONE (218) 285-5111

Circle 421 on inquiry card.

**BOTHWARE**

HARDWARE SOFTWARE

\*\*\* ANNOUNCING THE BOTHWARE 8073 \*\*\*

The Bothware 8073 is a self contained computer based on the National Semiconductor 1808073 microprocessor. The board makes both software and hardware design easier. Both "Bothware". The following are some of its features:

- Runs on a 900 Apple II+ with DOS 3.5
- High Level Language (HLL) primary language development productivity information interpreter (HLL) BASIC software with control language including:
  - Interruptable
  - Interruptable
  - Interruptable
- Large memory area for implementing your design.
  - 64 Kbytes of user memory
  - 64000 words of 16 bit words
  - 64000 words of 8 bit words
  - 64000 words of 16 bit words
  - 64000 words of 8 bit words
- Supports up to 8 hardware devices
- Supports up to 8 hardware devices
- Supports up to 8 hardware devices

Don't miss out on this opportunity. Call today for more information. Bothware 8073 is available in kit form. Price: \$199.95. Bothware 8073 is available in kit form. Price: \$199.95.

**Bothware 8073**  
1808073, INC. Box 136  
P.O. Box 136, San Jose, CA 95131  
MADE IN U.S.A. TEL: 415-435-2811

Circle 298 on inquiry card.

**telecommunications? use SOFTCOM®**

SOFTCOM is a CP/M based communications utility which can be used as an intelligent terminal program and as a CP/M to CP/M file transfer utility. Intelligent terminal mode supports 300/1200 baud modems. Data sent to the host computer can be entered at the terminal or it can be sent directly from disk files. Data received from the host can be saved in disk files and/or printed.

File transfer mode supports transfers of text and binary files with error detection and automatic retry. Three license options are available: single CPU (\$150), dual CPU (\$250) and multi CPU (\$450). Call our software HOT LINE 906/228-7622.

**The Software Store**  
706 Chippewa Square • Marquette MI 49855

Circle 430 on inquiry card.

**PAL**  
Programmable Array Logic

**THE MICRO CAD**

**DIGITAL dmi MEDIA**  
INTRODUCING IPP100

INTELLIGENT PAL PROGRAMMING CAPABLE OF PROGRAMMING 8024 PER PAL FAMILY AND 2716/27163/27164 BY EPROMS. BUILT ON THE 3100 DOUBLE SIDED PCB WITH ON BOARD MICROBUS MICROCOMPUTER UNIT.

IPP100 HAS THREE BASIC MODES OF OPERATION

- OPERATES DIRECTLY WITH 8024 BUS
- WITH OUR 8100 EMULATOR/INTEGRATOR PC 232C OR PROGRAM PAL DIRECTLY FROM USER'S EPROM

THE IPP100 IS SOFTWARE COMPATIBLE WITH INTEL 8024 PAL ASSEMBLY. IF YOU ARE NOT FAMILIAR WITH THE SIMPLICITY OF THE PAL APPLICATION AND ITS DEVELOPMENT, WE RECOMMEND THAT YOU CONSULT "PAL PROGRAMMABLE ARRAY LOGIC HANDBOOK" AVAILABLE FROM DIGITAL MEDIA.

ITEM	AVAILABLE	PRICE
IPP100	Oct 81	\$789
8100 Emulator	Sept 80	\$120
IPP100 Emulator	Oct 81	\$995
8100 Emulator	Oct 81	\$120
8100 Emulator	Current	\$15
8100 Emulator	Current	\$15

TO ORDER ANY OF THE ABOVE, WRITE TO: D. M. J., 8440 W. BETH ST., LOS ANGELES, CA 90049 OR CALL: 813/870-1086 STANLEY FLAIA

Circle 78 on inquiry card.

**RELATIONAL DBMS IN CB-80 SOURCE**

FOR SYSTEM INTEGRATORS

- CB-80 & RMAC Source & RLL files for easy development of Turnkey Systems
- Separate overlays perform RETRIEVE, STORE, OPEN, DELETE, REPLACE & MODIFY operations, leaving more memory for application program.
- RETRIEVE dynamically joins more than one relation and sorts the results; no secondary links to reconstruct after storing data
- Numeric data is maintained in Binary format providing more capacity and flexibility than typical all-ASCII systems
- 24 BIT internal record numbers allow up to 16 MILLION DBMS records per relation

CB-80 Trademark of Digital Research, Inc

Basic System & Administration Pkg - \$350  
Query & Aggregation Languages - \$150  
Manual for All Software - \$25 (refundable)

Telephone for Complete Brochure  
**Applied Business Concepts, Inc.**  
PO Box 22664 / Rochester, NY 14692  
(716) 425-1271

Circle 14 on inquiry card.

**Verbatim® Diskettes**

Top-quality Verbatim® Diskettes from Tech•Data, your complete word and data processing supply center. Dealer inquiries invited.

Call Toll Free  
**1-800-237-8931.**  
In Florida, call  
**813-577-2794.**

**Tech•Data Corporation**  
3251 Tech Drive North  
St. Petersburg, FL 33702

Circle 528 on inquiry card.



P.O. Box 4430X
Santa Clara, CA 95054
Will call: 2322 Walsh Ave.
(408) 988-1640

Same day shipment. First line parts only. Factory tested. Guaranteed money back. Quality IC's and other components at factory prices.

INTEGRATED CIRCUITS

Phone orders only (800) 538-8196

Table listing various integrated circuits with part numbers, descriptions, and prices. Includes sections for 7400 Series, 74100 Series, 74200 Series, 74300 Series, 74400 Series, 74500 Series, 74600 Series, 74700 Series, 74800 Series, 74900 Series, and 74000 Series.

INTRODUCING A BRAND NEW MICROCOMPUTER



VENTURE is a single board computer that is an adventure for the hobbyist. It is a learning, training computer as well as just plain fun for anyone who wants to get into a state-of-the-art computer at reasonable cost.

maps; it has 64 levels of grayscale plus video in-vert/complement and hidden screen update for a "snow" free display. The display is 512 x 512 pixel mapped with 2 planes of video RAM per display. VENTURE video is in short...astounding!

VENTURE comes in kit form or fully assembled and tested. You can get it in its minimum configuration for as little as \$195.00 or take it all the way to floppy disks and voice. It can be expanded as a kit or fully assembled, at your own pace and choice.

VENTURE has complete software support with full BASIC, 3 ROM monitors, 16 channel A to D; 5 slot 60 pin bus, 2 serial ports, parallel ports; 3 video options, 48K RAM, Voltrex voice synthesizer, sound generator, EPROM; full BASIC disassembler, editor, assembler; metal cabinet, additional power supply, ASCII keyboard real time clock/calendar.

A standard 60-pin bus with 5 slots, parallel ports and 2 serial ports with full handshaking (75 to 9600 BAUD) allow expansion into floppy disks, color EPROM programmer, printer, modem of your choice. Later expansion will add a light pen, a universal user programmable music sound board, General Purpose Instrument Bus, and a high resolution color/grayscale pixel mapped video board.

VENTURE connects directly to a monitor or to your TV set through an RF modulator. And now for the heart of VENTURE... its video display. VENTURE has a high resolution programmable video display with up to 4096 user-defined characters, alphanumeric symbols, special graphics or objects, such as space ships, etc. Each character is 8 pixels wide by 15 pixels high, with 2 grayscale

A 16-channel analog-to-digital converter allows use of joystick, control functions, instrumentation, temperature sensing, etc. T1 sound generator, software controlled music, Voltrex voice synthesizer and real time clock/calendar add to its versatility.

Expansion Options
Floppy disk, EPROM programmer, light pen, universal user programmable music, sound board high resolution color/grayscale pixel mapped video board, General Purpose Instrument Bus. Minimum VENTURE System \$195.00. Kit includes CPU and control with 4K of RAM, 1K of scratchpad, 2K monitor, 1861 video graphics, cassette interface and separate HEX keyboard with LED displays for address and output. Power supply is included along with 2 game cassettes. The main board is 16" x 20" and includes space for all of the previously discussed on-board options. Full on-board expansion can be completed for under \$1000.00. Call for further details, option prices, etc.

Special Products
2.5 MHz 8088 CPU \$17.95
30 MHz 8088 CPU \$25.95
30 MHz 8088 CPU \$25.95
AC TRANSFORMERS
60/250 MA \$4.00
60/100/170/250 MA \$7.95
60/300/500 MA \$12.95
60/750/1000 MA \$19.95
60/1500/2000 MA \$29.95
60/3000/4000 MA \$49.95
60/6000/8000 MA \$79.95
60/12000/16000 MA \$119.95
60/24000/32000 MA \$179.95
60/48000/64000 MA \$279.95
60/96000/128000 MA \$439.95
60/192000/256000 MA \$679.95
60/384000/512000 MA \$1039.95
60/768000/1024000 MA \$1559.95
60/1536000/2048000 MA \$2339.95
60/3072000/4096000 MA \$3519.95
60/6144000/8192000 MA \$5279.95
60/12288000/16384000 MA \$7919.95
60/24576000/32768000 MA \$11759.95
60/49152000/65536000 MA \$17519.95
60/98304000/131072000 MA \$26279.95
60/196608000/262144000 MA \$39439.95
60/393216000/524288000 MA \$58659.95
60/786432000/1048576000 MA \$87519.95
60/1572864000/2097152000 MA \$131159.95
60/3145728000/4194304000 MA \$197719.95
60/6291456000/8388608000 MA \$293519.95
60/12582912000/16777216000 MA \$439279.95
60/25165824000/33554432000 MA \$658839.95
60/50331648000/67108864000 MA \$988399.95
60/100663296000/134217728000 MA \$1482399.95
60/201326592000/268435456000 MA \$2223599.95
60/402653184000/536870912000 MA \$3335199.95
60/805306368000/1073741824000 MA \$5003199.95
60/1610612736000/2147483648000 MA \$7504799.95
60/3221225472000/4294967296000 MA \$11257199.95
60/6442450944000/8589934592000 MA \$16935199.95
60/12884901888000/17179869184000 MA \$25403199.95
60/25769803776000/34359738368000 MA \$38107199.95
60/51539607552000/68719476736000 MA \$56615199.95
60/103079215104000/137438953472000 MA \$84923199.95
60/206158430208000/274877906944000 MA \$127383199.95
60/412316860416000/549755813888000 MA \$191163199.95
60/824633720832000/1099511627776000 MA \$281803199.95
60/1649267441664000/2199023255552000 MA \$418203199.95
60/3298534883328000/4398046511104000 MA \$618603199.95
60/6597069766656000/8796093022208000 MA \$914203199.95
60/13194139533312000/17592186444416000 MA \$1356203199.95
60/26388279066624000/35184372888832000 MA \$2014203199.95
60/52776558133248000/70368745777664000 MA \$2946203199.95
60/105553116266496000/140737491555328000 MA \$4314203199.95
60/211106232532992000/281474983110656000 MA \$6318203199.95
60/422212465065984000/562949966221312000 MA \$9214203199.95
60/844424930131968000/1125899932442624000 MA \$13514203199.95
60/1688849860263936000/2251799864885248000 MA \$19914203199.95
60/3377699720527872000/4503599729770496000 MA \$29114203199.95
60/6755399441055744000/9007199459540992000 MA \$42714203199.95
60/1351079888211119168000/18014398919081984000 MA \$63114203199.95
60/2702159776422238336000/36028797838163968000 MA \$92714203199.95
60/5404319552844476672000/72057595676327936000 MA \$136714203199.95
60/10808639105789313344000/144115191352655872000 MA \$200714203199.95
60/21617278211578626688672000/288230382705311744000 MA \$294714203199.95
60/4323455642315725337344000/576460765410623488000 MA \$430714203199.95
60/8646911284631445070688672000/1152921530821246976000 MA \$634714203199.95
60/1729382257326289014137344000/2305843061642493952000 MA \$924714203199.95
60/34587645146525780282768000/4611686123284987904000 MA \$1354714203199.95
60/69175290293051565655536000/9223372246569975808000 MA \$1994714203199.95
60/1383505845861031311311104000/18446744493139951616000 MA \$2934714203199.95
60/2767011691722062622622208000/36893488986279903232000 MA \$4314714203199.95
60/553402338344412525252525208000/73786977972559806464000 MA \$6354714203199.95
60/1106804776688248505050505056000/147573955945119612928000 MA \$9254714203199.95
60/2213609553376497010101010112000/2951479118902392384000 MA \$13554714203199.95
60/4427219106753954020202020224000/5902958237804784768000 MA \$19954714203199.95
60/8854438213507908040404040448000/11805916475609569536000 MA \$29354714203199.95
60/1770887642701801608080808096000/23611832951213913072000 MA \$43154714203199.95
60/3541775285403603216161616192000/47223665902427226144000 MA \$63554714203199.95
60/7083550570807206432323232384000/94447331804854452288000 MA \$92554714203199.95
60/1416710114161441246448484896000/18889463560970890455744000 MA \$135554714203199.95
60/28334202283228824928969696192000/377789271219417811111488000 MA \$199554714203199.95
60/56668404566457649857939393384000/75557854243883562223376000 MA \$293554714203199.95
60/113336809132915529775787757776000/1411157044777671244446752000 MA \$431554714203199.95
60/22667361826581104595555555552000/282231408955534448889504000 MA \$635554714203199.95
60/4533472365316110919111111114000/564462817910888897777792000 MA \$925554714203199.95
60/90669447306322221838383838384000/1128925635421777777777776000 MA \$1355554714203199.95
60/181338894612644436777777777776000/225785127084355555555552000 MA \$1995554714203199.95
60/36267778922528887355555555556000/451570254168711111111114000 MA \$2935554714203199.95
60/72535557845177774711111111112000/903140508337422222222224000 MA \$4315554714203199.95
60/1450711569093555554733333333334000/180628101667444444444448000 MA \$6355554714203199.95
60/2901423138187111111477777777776000/361256203334888888888896000 MA \$9255554714203199.95
60/5802846276374222222477777777776000/722512406669777777777792000 MA \$1355554714203199.95
60/1160569255274844444477777777776000/144502481339555555555552000 MA \$1995554714203199.95
60/2321138510549688888777777777776000/289004962679111111111114000 MA \$2935554714203199.95
60/46422770211193777777777777776000/578009925358222222222224000 MA \$4315554714203199.95
60/9284554042238755555577777777776000/115601970717644444444448000 MA \$6355554714203199.95
60/185691080845751111111477777777776000/231203941434888888888896000 MA \$9255554714203199.95
60/371382161691511111111477777777776000/462407882869777777777792000 MA \$1355554714203199.95
60/74276432338302222222477777777776000/92481576573955555555552000 MA \$1995554714203199.95
60/1485528466766444444477777777776000/184963153147911111111114000 MA \$2935554714203199.95
60/2971056933332888888877777777776000/369926306295822222222224000 MA \$4315554714203199.95
60/594211386666577777777747777777776000/73985261259164444444448000 MA \$6355554714203199.95
60/118842273333115555555547777777776000/147970522582328888888896000 MA \$9255554714203199.95
60/237684546666231111111147777777776000/295941045164677777777792000 MA \$1355554714203199.95
60/47536909333262222222247777777776000/59188209032935555555552000 MA \$1995554714203199.95
60/95073818666524444444477777777776000/118376418065871111111114000 MA \$2935554714203199.95
60/190147673333148888888877777777776000/236752836131742222222224000 MA \$4315554714203199.95
60/3802953466662977777777774777777776000/47350567226348444444448000 MA \$6355554714203199.95
60/760590693333595555555547777777776000/947011344526877777777792000 MA \$9255554714203199.95
60/15211813866661191111111147777777776000/18940226895375555555552000 MA \$1355554714203199.95
60/3042362773333382222222247777777776000/378804537907511111111114000 MA \$1995554714203199.95
60/608472546666764444444447777777776000/757609075815022222222224000 MA \$2935554714203199.95
60/12169450933331528888888877777777776000/15152181516300444444448000 MA \$4315554714203199.95
60/243389018666630577777777774777777776000/30304363032600888888896000 MA \$6355554714203199.95
60/486778037333361155555555547777777776000/6060872606520177777777792000 MA \$9255554714203199.95
60/973556074666612233333333334777777776000/12121745130403555555552000 MA \$1355554714203199.95
60/194711214933332446666666667777777776000/242434902608071111111114000 MA \$1995554714203199.95
60/3894224298666648933333333334777777776000/484869805216142222222224000 MA \$2935554714203199.95
60/7788448597333397866666666667777777776000/96973961043228444444448000 MA \$4315554714203199.95
60/155769719946667577333333333334777777776000/19393982208645688888896000 MA \$6355554714203199.95
60/3115394398933311555555555554777777776000/3878796441729137777777792000 MA \$9255554714203199.95
60/6230788797866631111111111114777777776000/77575928834582755555552000 MA \$1355554714203199.95
60/1246157595573333222222222224777777776000/1551518776711555555552000 MA \$1995554714203199.95
60/2492315191156666444444444447777777776000/310303755342311111111114000 MA \$2935554714203199.95
60/498463038231111111111147777777776000/62060751068462222222224000 MA \$4315554714203199.95
60/996926076462222222222247777777776000/12412150213692444444448000 MA \$6355554714203199.95
60/199385215292444444444447777777776000/2482430042738488888896000 MA \$9255554714203199.95
60/398770430584888888888877777777776000/496486008547697777777792000 MA \$1355554714203199.95
60/797540861177777777777774777777776000/9929720170953955555552000 MA \$1995554714203199.95
60/1595081355555555555555547777777776000/1985944034190791111111114000 MA \$2935554714203199.95
60/3190162711111111111111147777777776000/397188806838158222222224000 MA \$4315554714203199.95
60/638032542222222222222247777777776000/79437761366316744444448000 MA \$6355554714203199.95
60/127606508444444444444447777777776000/15887552272263488888896000 MA \$9255554714203199.95
60/255213016888888888888877777777776000/3176510454452687777777792000 MA \$1355554714203199.95
60/510426033777777777777774777777776000/63530209089053755555552000 MA \$1995554714203199.95
60/1020852075555555555555547777777776000/127060418178111111111114000 MA \$2935554714203199.95
60/2041704151111111111111147777777776000/25412083635622222222224000 MA \$4315554714203199.95
60/408340830222222222222247777777776000/508241672712444444448000 MA \$6355554714203199.95
60/816681660444444444444447777777776000/101648334542488888896000 MA \$9255554714203199.95
60/163336332088888888888877777777776000/20329666908497777777792000 MA \$1355554714203199.95
60/326672664177777777777774777777776000/406593338169955555552000 MA \$1995554714203199.95
60/6533453283555555555555547777777776000/813186676339911111111114000 MA \$2935554714203199.95
60/1306690656711111111111147777777776000/162637335267982222222224000 MA \$4315554714203199.95
60/261338131342222222222247777777776000/32527467053596444444448000 MA \$6355554714203199.95
60/522676262684444444444447777777776000/6505493410719288888896000 MA \$9255554714203199.95
60/104535252536888888888877777777776000/129109868214397777777792000 MA \$1355554714203199.95
60/209070505073777777777774777777776000/2582197364287955555552000 MA \$1995554714203199.95
60/41814101014755555555555547777777776000/516439472857591111111114000 MA \$2935554714203199.95
60/8362820202951111111111147777777776000/103287894515516222222224000 MA \$4315554714203199.95
60/1672564045902222222222247777777776000/20657578903102444444448000 MA \$6355554714203199.95
60/3345128091804444444444447777777776000/4131515780620488888896000 MA \$9255554714203199.95
60/669025618368888888888877777777776000/82630315612417777777792000 MA \$1355554714203199.95
60/133805123773777777777774777777776000/165260631248355555552000 MA \$1995554714203199.95
60/26761027554755555555555547777777776000/330521262496711111111114000 MA \$2935554714203199.95
60/5352205510951111111111147777777776000/66104252499342222222224000 MA \$4315554714203199.95
60/10704411021911111111111147777777776000/1322085049868444444448000 MA \$6355554714203199.95
60/2140882204382222222222247777777776000/264417009973688888896000 MA \$9255554714203199.95
60/428176440876444444444447777777776000/52883401994737777777792000 MA \$1355554714203199.95
60/856352881728888888888877777777776000/105766803894755555552000 MA \$1995554714203199.95
60/171270563457777777777774777777776000/211533607789511111111114000 MA \$2935554714203199.95
60/342541126911555555555555477777

**AUDEC-1**  
the EAR & MOUTH for  
APPLE & AIM-65



- Recognition and Response in One Unit
- You can make your own vocabulary
- Good Speech Quality
- Up to 98% Recognition Accuracy
- In a 3 1/2" x 5 3/4" x 1 1/4" Box
- Assembled and Fully Tested
- EPROM Version avoids cassette loading

**\$169.00 ea.** plus shipping and handling  
charge: U.S \$5.00 Overseas, 10%

NJ Residents, add 5% sales tax.

— VISA, Mastercharge Welcome —

**AUDEC CORPORATION (Dept. LA)**  
728 Larch Avenue  
Teaneck, NJ 07666 (201) 692-1720

Circle 42 on Inquiry card.

**8086/8088**  
**FIRMWARE DESIGNERS**  
**SYSTEMS**  
**PROGRAMMERS**

Now you have the choice between  
PL/M or assembler. Use the

**c-systems**  
**C COMPILER**

on the IBM PC (MSDOS).

- Outputs assembler source code.
- All byte and integer operators.
- PL/M compatibility mode.
- Price \$195.

Contact:

**c-systems** Fullerton, CA 92631  
221 N. Berkeley Ave. 714-879-1123

Circle 74 on inquiry card.

Get Serious About

**ZX81**



Computing

**PROFESSIONAL KEYBOARD** Makes your ZX81 easier to use. Enter programs quickly and error-free. Plugs straight into your ZX81 without any soldering. Has 47 keys and a full space bar. **\$85.00**

**32K RAM.** Expand the memory capacity of your ZX81 with this direct-plug-in module. Fully compatible with Sinclair's 16K RAM (to give your ZX81 system a full 48K). **\$99.95**

**64K RAM.** Expand your ZX81 memory capacity to its maximum. Plugs in directly to your ZX81. **\$149.95**

Software on Cassette

MULTIFILE PLUS.	GAMES	
Data storage system for 16K to 64K systems. Flexible user-defined setup. Includes program tape, detailed instruction manual, 3 data tapes, storage case.	MAZOGS A maze-adventure INVADERS 10 levels of play STAR TREK Zax the Kingpin DICTATOR Political adventure	\$9.95 \$9.95 \$9.95 \$14.95

Call (716) 874-5510 for Visa, MC Orders.

**GLADSTONE** Electronics

Mail order to 1585 Kenmore Ave., Buffalo N.Y. 14217  
Checks or money orders. No CODs. Add shipping.

Circle 204 on inquiry card.

**REAL TIME SOFTWARE**

We offer professional, proven software expertise in the following real time areas.

- multi tasking executive
- pipeline/ industrial control
- remote data acquisition and control
- instrumentation/ communications interfaces
- specialized computation packages

**Micros our specialty**

L. R. Schneider, MSEE



**CALTA**  
Computer  
Systems Ltd

P.O. Box 815, Station "T",  
Calgary, Alberta T2H 2H3  
(403) 252-5094

Circle 76 on inquiry card.

**Verbatim®**  
**Floppy Discs**

**SAVE 40%** Write for our complete list.

5 1/4" Specify soft, 10 or 16 sector	Price/10
MD525 1 side/dbl dens. ....	\$27.30
MD550 2 sides/dbl dens. ....	40.30
MD577 1 side/77 track. ....	37.10
MD557 2 sides/77 track. ....	47.60

8" Critically Certified Soft sector	
FD34-9000 1 side/sgl dens. ....	33.80
FD34-8000 1 side/dbl dens. ....	39.00
FD34-4001 2 side/dbl dens. ....	46.20

CHECKS - VISA - MC - C.O.D.  
(313) 777-7780 ADD \$2 SHIPPING

**LYBEN COMPUTER SYSTEMS**  
27204 Harper Ave.  
St. Clair Shores, MI 48081

Circle 274 on inquiry card.

**5 1/4" Floppy Disk Drives**

(Direct IBM® Plug-in)

**TANDON Model TM 100-1 .. \$199\* ea.**  
**TANDON Model TM 100-2 .. \$299\* ea.**  
12" Green Phosphor Zenith Monitor \$109\* ea.

Also available - TM 602S, 603S, and 603E Winchester Drives

**For info or orders**  
call — 316-683-9225  
or 316-685-9445

MC / VISA or C.O.D. with certified check or money order. Kansas residents add 3% sales tax.

\* Plus shipping.



**G-H Computer Systems, Inc.**  
923 Longfellow Street  
Wichita, KS 67207

Circle 203 on inquiry card.

**FORTH-32™**  
**IBM PC**

The FORTH-32™ DEVELOPMENT SYSTEM features Intel 80386 and 32 bit addressing modes with 80387 FORTH compatibility, DOS interface, full screen editor, assembler, disassembler, graphics and debug. The powerful QUEST CASE statement with single, multiple and range labeling is also included.

In addition to FORTH-32™ you will receive the QUEST PACKAGE BUILDER UTILITY which requires no user developed programs into marketable software packages by building on disk a condensed executable image with only those FORTH words needed.

User oriented and teaching documentation! All software is fully backed and updated for one year!

800 FORTH-32 (SPECIFY PC/DOS, CP/M/MS-DOS)  
330 FLOATING POINT LIBRARY (SPECIFY SOFTWARE OR HARD)

FORTH-32 AND QUEST ARE TRADEMARKS OF QUEST RESEARCH INC.  
IBM IS A REGISTERED TRADEMARK OF IBM CORPORATION.  
PC/MIP IS A TRADEMARK OF DIGITAL RESEARCH INC.

**Quest™**



**QUEST RESEARCH, INC.**  
P.O. BOX 2553  
HUNTSVILLE, AL 35804

Call Toll Free  
(800) 568-8068  
In Alabama Call  
(205) 533-9405

Circle 397 on inquiry card.

FREE

POCKET SOLAR CALCULATOR W/\$500 ORDER\*

up to 40%

DISCOUNT OFF RETAIL

COMPLETE LINE OF

MICRO & CP/M SOFTWARE

ALTOS-DYNABYTE-XEROX-SANYO-NEC-ATARI

PIIICEON-TELEVIDEO-STAR-OLIVETTI-VIC-

C. ITOH-IDS-APPLE-MAXELL-DIABLO-EPSON

COMREX-TALLY-ADDS-TI-MONITORS-CORVUS

MODEMS-TRS-80-SCM-X-COMP-ZENITH-DEC-

3M-CHANG LAB-LIFE BOAT-COMPUTER PAPER

HOME \* OFFICE \* INDUSTRY

SEND FOR A FREE CATALOGUE

DATAWARE INC.

BOX 1122, 1615 WILCOX AVE.  
HOLLYWOOD, CA. 90028  
(213) 465-9751

\*WHILE SUPPLIES LAST

Circle 151 on inquiry card.

**5 1/4" Tandon Drives**

• <b>TM 100-1</b> (single sided, 40 TRK, single or double density)	<b>\$199</b> Free Shipping
• <b>TM 100-2</b> (double sided, 40 TRK/side single or double density)	<b>\$279</b> Free Shipping
• <b>TM 100-4</b> (double sided, 80 TRK/side 96 TPI, double density)	<b>\$359</b> Free Shipping

ORDER — TOLL FREE —

1-800-531-5255 (if outside of Texas)

1-800-252-9146 (if in Texas)

ask for extension 811.

For info call 1-512-250-1523

Master Card/Visa or check.  
Texas Residents add 5% sales tax.

**CompuAdd Corp.**  
13010 Research Blvd. #207  
Austin, Texas 78750

Circle 99 on inquiry card.

# INCREDIBLE? BELIEVE IT!

## Washington Computer Services

an affiliate of **WASHINGTON ELECTRIC COMPANY** est. 1912

CUSTOM COMPUTER ROOM WIRING SINCE 1960

97 Spring Street, New York, New York 10012

TO ORDER: CALL OUR TOLL-FREE NUMBER: (800) 221-5416

In N.Y. State and for technical information: (212) 226-2121

HOURS: 9 AM - 5:30 PM (EST) Monday-Friday

TELEX: 12-5606 CABLE: WASHCOMP NYK

### PRINTERS

	Teletype 40, 300 LPM-typewriter quality, RS-232 interface. This quality printer is available in many configurations including forms access, quietized case, etc.	from Only \$3200
	Teletype 43	from \$995
	Teletype AP-200, 340 cps dot matrix (similar to Data Prod. M-200)	\$2799
	Qantex 7030, 180 cps, Download fonts, OCR Bar, NLO Graphics	\$1795
	NEC Spinwriter 35 cps & 55 cps, bidirectional, letter quality	from \$1875
	DIABLO 630-40 cps, bidirectional, daisy wheel, plot/graph	\$2349
	QUME Sprint 9/35 cps, daisy wheel	\$1944
	C. ITOH Starwriter, 40 cps, daisy wheel, F10	\$1550
	EPSON MX-80, 100, 80 cps, 9x9 dot matrix	SCALL
	ANADIX 9500/9501A, up to 200 cps, high resolution dot	\$1451
	OKIDATA Microline 82A \$480 Microline 83A \$770	
	T1-810, 150 cps, Basic \$1449 Package-CP,VFC	\$1630
	MANNESMANN MT 1705 200 cps, 7x9, 132 col	SCALL
	TALLY MT 1805 200 cps, 7x9 + NLO 40x18 matrix	SCALL
	CENTRONICS 739 100 cps, nx9 dot matrix, Full Graphics	\$567
	122 120 cps, international set, Full Graphics, 15" paper	\$987
	DEC LA-34	\$1085
	IDS PRISM, 132 col., color	\$1785

Similar savings for our C. ITOH, NEC, QANTEX, DATA GEN. lines

### TERMINALS

	PMMI MODEM	\$359
	AMPEX DIALOGUE 30, 80, 81 Lowest Prices	SCALL
	TELEVIDEO 910 C (multi-terminal)	\$610
	925C	\$795
	950C	\$985
	AMPEX Dialogue 81*	\$799
	SOROC IQ 120	\$618
	HAZELTINE ESPRIT	\$1575
	DEC VT-100	SCALL
	Visual 50—Multi-terminal, Detached Keyboard	\$669
	Zenith ZT-1, 80x24, autodial modem, VT-52 compatible.	

Similar savings for our ADDS, HAZELTINE and LEAR SIEGLER lines



### SOFTWARE

DBASE II	\$525	WORDSTAR	\$300
MBASIC-80	\$275	MAILMERGE	\$110
MBASIC COMPILER	\$316	DATASTAR	\$230
FORTRAN-80	\$349	CONDOR III	\$716
COBOL-80	\$574	MILESTONE	\$235
PL/1-80	\$425	SUPERCALC	\$221
PASCAL MT + V5.5	\$398	FMS-80	\$649
WHITESMITH'S C	\$660	SELECTOR V	\$396
CB-80	\$420	SPELLGUARD	\$236
PEARL (LEVEL 3)	\$549	SUPERSOFT	SCALL
LIFERDAT SOFTWARE	SCALL	AMERICAN BUS. SYST.	SCALL
PEACHTREE	SCALL	ACCOUNTING PLUS	SCALL
GRAHAM-ODRIAN	SCALL	BSTAM, BSTMS	\$200
STRUCTURED SYST.	SCALL	VANDATA/OSBORNE	\$500

8" SDSS; Call For Other Formats

### 8" DISK DRIVE SALE

NOW!

8" SHUGART SA801R	\$385	8" SHUGART SA 851R	\$540	2 for \$1025
QUME DATATRACK 8			\$550	2 for \$1050
Enclosure, power supply for 2 8" drives A & T				\$350
MORROW DISCUS 20 + CP/M®, MICROSOFT BASIC, CONT.				\$950

### HARD DISK SPECIALS

CORVUS 5MB, 10MB, 20MB Constellation Multiplexer and Mirror Backup	
MORROW 26MB + controller + CP/M 2.2®, M basic	\$3821
controller, CDC Hawk Drive (5 fix, 5 rem)	\$6795
controller, Western Dynex (5 fix, 5 rem)	\$5099
5 1/4", 8" and 14" Winchester / tape subsystems available	

### KONAN

### FULLY CONFIGURED BUSINESS SYSTEMS

The following are some examples of the fully assembled and tested business and scientific computer systems which we offer.

	The Premier Multi-User Computer System	
	8000 SX, multi-user, multi-processor, turbo DOS	SCALL
	CPM 2.2. FULL 2 YEAR WARRANTY!	
	On-Site Service Contracts Available	
	APC-8086, 16 bit, 128K, 8" DRIVES, 1024x1024 Color	
	Graphic, 32 bit F.P. Proc., MS DOS, CP/M 86	from \$3295
	PC-8000 The Professional's Work Station.	SCALL
	CORVUS Concept—68000, 32 bit, 256k, network, 15" 120x56	
	+ HiRes screen, W.P. software, CP/M Emulator	from less than \$5000
	68000 16 bit multi-user, S-100, UNIX V.7	SCALL

	8086 16 bit, 128K RAM, S-100, Syst. #2	\$3499
	Call us for best prices on these high quality 2nd generation boards and systems.	

	These high quality, reliable products have made CCS defacto industry standard for S-100 products	
	Assembled and tested:	SCALL
	InterSystems Fast 6 Mhz, Cache Bios Computers	SCALL
	ADVANCED MICRO DIGITAL Single Board S-100 Computers	\$749

 We offer generous discounts on the Compupro line of fast, quality 8 and 16 bit boards

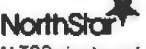
	ADVANTAGE Graphics computer & HORIZON S-100 computer	SCALL
	ALTOS single and multi-user systems	SCALL

	Decision 1, CP/M Microsoft Basic, UNIX	SCALL
---	--	-------

	820 Desktop computer-64K, 2 floppys. (CP/M avail.)	SCALL
	List \$2995	SCALL
	SCION MicroAngelo Hi Res Graphics systems	SCALL

Similar savings on SSM, DELTA, DYNABYTE, TELEVIDEO, DIGIAC, ZENITH, ADDS, DEC, DATA GEN., ATARI, TECMAR AND MANY OTHERS

**PLEASE!** Do not confuse us with mail order dealers. We are a full service distributor serving the data processing & installation needs of business & industry from micros to mainframes. System houses, Educational institutions & governmental agencies given special consideration. Leasing available.

N. Y. State agencies, municipalities, and schools — call us for information on our O.G.S. term contracts on hardware & software.

## DEALER and INTERNATIONAL INQUIRIES WELCOME

For fast delivery, send certified check, money order or call to arrange direct bank wire transfer. Personal or company checks require two to three weeks to clear. Prices subject to change without notice; call for latest prices. Prices include 3% cash discount. N.Y. residents add sales tax. Qantex is a trademark of North Atlantic Industries, Inc. Radio Shack® is a trademark of the Tandy Corp. CP/M® is a trademark of Digital Research. All sales subject to our standard sale conditions (available on request). Call for shipping charges. Above prices do not include customization or installation.

## dasityper. 40

PRINTER - TYPEWRITER



NOW SYSTEMED OFFERS THREE!

● MODEL D30 ● MODEL D35

AND INTRODUCING THE MODEL 40

IT'S AN OLIVETTI PRAXIS 40 FULL-SIZE ELECTRONIC TYPEWRITER WITH A 13 INCH CARRIAGE, ANTI-GLARE ACOUSTIC COVER, STEEL DRUMBAND & OUR NEW COMBINATION SERIAL/PARALLEL KSR TERMINAL INTERFACE, THIS ONE'S REALLY STURDY!!!

(MODELS BEGIN AT \$789.00)

CALL OR WRITE FOR FREE BROCHURE

SYSTEMED CORPORATION

P.O. Box 18, Shingletown Road  
Mountain City, Tennessee 37643  
(615) 727-6000



Circle 447 on inquiry card.

## price or quality?

Get both... with a MICRO CONNECTION, the quality, direct connect, Bell 103 modem. Independent reviewer writes, "When the going gets rough, if a MICRO-CONNECTION can't make it, then nothing will. In the area of sensitivity and noise elimination, it will perform as good or better than my \$995" modem. An excellent value for \$159. Autodial/Autoanswer for \$199.

the microperipheral corporation

2643 151st Place N.E.,  
Redmond, WA 98052

(206) 881-7544



Circle 318 on inquiry card.

## BIG STEPPER

Stepping-Motor Driver Box

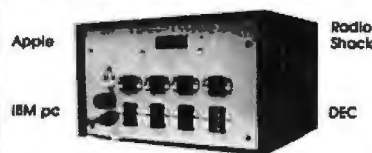

Control precise motion in the "real world"!

Drives 1 to 4 Stepping-Motors (up to 2 amps/winding, 4 to 28 volts) Optimized for your computer's safety

PRICE: \$350

Stepping-Motor Cookbook: \$5.00

Centre Computer Consultants

Post Office Box 739

State College, PA 16801

(814) 237-4535

Circle 81 on inquiry card.

YOU'VE JUST  
FOUND



## THE MISSING LINK!

Computer Shopper is your link to individuals who buy, sell and trade computer equipment and software among themselves nationwide. No other magazine fills this void in the marketplace chain.

Thousands of cost-conscious computer enthusiasts use Computer Shopper every month through hundreds of classified ads. And new equipment advertisers offer some of the lowest prices in the nation.

Subscribe to Computer Shopper with a 6 month trial for \$6 or 12 months for only \$10. MasterCard & VISA accepted

COMPUTER SHOPPER

P.O. Box F-310 • Titusville, FL 32780

305-269-3211

Circle 115 on inquiry card.

## TeleVideo<sup>®</sup> USERS!

Enhance your TeleVideo computer capabilities with OUR exclusive software!

COGITATE Fast Dump/Restore System for TS

802H, 806 & 1602H

- Back-up files twice as fast as PIP
- Double the storage, up to 600K/diskette, with multiple diskette capability

\$90.00

COGITATE Keyboard Buffer for TS 800, 802 & 802H

- Never lose a keystroke
- Interrupt driven 64 byte buffer
- Compatible with CP/M\* operating system

\$40.00

COGITATE 2780/3780 Communications System.

- Communicates with most IBM systems
- Many features for remote job entry

\$700.00

CP/M\* is registered trademark of Digital Research, Inc.

COGITATE, Inc.

SPECIALISTS IN UNIQUE TELEVIDEO SOFTWARE

24000 Telegraph Road, Southfield, MI 48034

(313) 352-2345

VISA/MASTER CARD Accepted

Circle 88 on inquiry card.

## MEMOREX FLEXIBLE DISCS

WE WILL NOT BE UNDER-SOLD! Call Free (800)235-4137 for prices and information. Dealer inquiries invited and C.O.D.'s accepted.

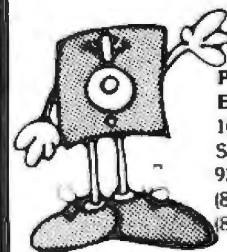

PACIFIC EXCHANGES

100 Foothill Blvd.  
San Luis Obispo, CA  
93401 In Cal call  
(800)592-5935 or  
(805)543-1037

Circle 356 on inquiry card.

## 64 K

DYNAMIC RAMS and EPROMS

TOSHIBA

HITACHI

FUJITSU

NEC

OKI

MITSUBISHI

WHOLESALE AND RETAIL

Monarchy Engineering Inc.

380 Swift Avenue, Unit 21

So. San Francisco, CA 94080

Phone (415) 873-3055

WRITE OR CALL FOR OUR  
LATEST INVENTORY LIST.

Circle 327 on inquiry card.

## IEEE-488 TO TRS-80\* INTERFACE

Everything needed to add powerful BASIC GPIB-488 controller capability to TRS-80 Model 1 or 3, Level 2 or DOS with a minimum of 16K.



488-80C

For Model 3

Operation

488-80B

For Model 1

Operation



Model 488-80B or 488-80C Price: \$375.

+ shipping, insurance & tax

WHEN ORDERING SPECIFY DISK OR TAPE

SCIENTIFIC ENGINEERING  
LABORATORIES

11 Nell Drive • Old Bathpage, NY 11804

Telephone: (516) 694-3370

\*Trademark of Tandy Corp

There is no affiliation between Scientific Engineering Laboratories and Tandy Corp. or Radio Shack.

Circle 415 on inquiry card.

## THE LAST ONE

THE PROGRAM THAT WRITES PROGRAMS

AVAILABLE FOR

CP/M

Apple II Plus

Sharp PC 3201

TRS - 80 MOD II

North Star Advantage

Still Only \$600.00

Dealer Inquiries Invited

Send to KROWN COMPUTING

1282 Conference Dr., P.O. 66763

Scotts Valley, CA 95066

(408) 335-3133

Circle 280 on inquiry card.



# DoKay Computer Products, Inc.

VISIT OUR RETAIL STORE  
AND RECEIVE A 5% DISCOUNT!

3250 KELLER STREET, #9 • SANTA CLARA, CA 95050

### EPROMS

1702	(1ns)	3.00
2708	(45ns)	2.99
2716	(5v 45ns)	3.95
2716-1	(5v 35ns)	8.50
2532	(5v 45ns)	8.95
2732	(5v 45ns)	8.95
2764	(5v 45ns)	Call

### STATIC RAMS

2101	(450ns)	1.85
21L02	(250ns LP)	1.55
2111	(450ns)	2.49
2114	(450ns)	1.95
2114L-3	(300ns LP)	2.25
2114L-2	(200ns LP)	2.30
TMM2016	(200ns)	9.00
TMM2016	(150ns)	11.00
HM6116	(200ns)	Call
HM6116	(150ns)	Call
HM6116	(120ns)	Call

### DYNAMIC RAMS

4027	(250ns)	2.00
4116	(200ns)	1.37
4116	(150ns)	1.75
4164	(200ns)	Call

LP = Low Power

### 8000

8035	16.00	8239	4.75
8039	19.00	8243	4.75
8080A	3.90	8250	14.90
8085A	8.50	8251	4.50
8088	39.00	8253	8.75
8155	11.00	8253-5	9.75
8156	11.00	8255	4.50
8185	29.00	8255-5	5.20
8741	39.00	8257	8.50
8748	29.00	8259	6.85
8755	44.00	8272	39.00
8202	44.00	8275	29.00
8205	3.45	8279	9.25
8212	1.80	8279-5	10.25
8214	3.75	8282	6.50
8216	1.75	8283	6.50
8224	2.45	8284	5.50
8226	1.80	8286	6.50
8228	4.50	8287	6.50
8237	19.00	8288	25.00
8238	4.75	8289	49.00

### 16K APPLE RAM CARD

Upgrade your 48K Apple II to full 64K

BARE BOARD	24.00
KIT	49.00
ASSEMBLED & TESTED	69.00

### LEDS

Jumbo Red	10/1.00
Jumbo Green	6/1.00
Jumbo Yellow	6/1.00

### CONNECTORS

RS 232 Male	3.00
RS 232 Female	3.50
RS 232 Hood	1.20

### 6500

6502	6.90
6502A	9.45
6504	6.90
6505	7.65
6507	9.90
6520	4.35
6522	9.80
6532	13.95
6551	11.75

### Z80

Z80 A CPU	5.45
Z80 A PIO	5.45
Z80 A CTC	7.00

Call for Complete List

### MICROPROCESSOR

REAL-TIME CLOCK	
MSM 5832	
6.90	

### 6800

6800	5.65	6828	14.90	6860	10.90
6802	8.65	6834	16.90	6862	11.90
6808	8.45	6840	7.95	6875	6.90
6809	24.00	6843	41.95	6880	1.80
6809E	29.00	6845	16.90		
6810	3.50	6847	15.90	68B00	10.00
6820	3.50	6850	3.50	68B21	12.00
6821	3.50	6852	3.50	68B50	12.00

### CRYSTALS

32.768 KHZ	1.90	5.185	3.90
1.0 MHZ	4.50	5.7143	3.90
1.8432	4.50	6.5536	3.90
2.0	3.90	8.0	3.00
2.097152	3.90	10.0	3.00
2.4576	3.90	14.31818	3.90
3.2768	3.90	18.0	3.00
3.579545	3.90	18.432	3.00
4.0	3.00	20.0	3.00
5.0	3.00	22.1184	3.00
5.0688	3.90	32.0	3.90

### 74LS00 SERIES

74LS00	.24	74LS123	.95	74LS253	.80
74LS01	.24	74LS124	2.90	74LS257	.80
74LS02	.24	74LS125	.95	74LS258	.80
74LS03	.24	74LS126	.79	74LS259	2.80
74LS04	.24	74LS132	.75	74LS260	.60
74LS05	.24	74LS136	.49	74LS266	.49
74LS08	.24	74LS137	.95	74LS273	1.60
74LS10	.24	74LS138	.75	74LS275	3.25
74LS11	.30	74LS139	.75	74LS279	.49
74LS12	.30	74LS145	1.10	74LS280	1.95
74LS13	.40	74LS147	2.20	74LS283	.95
74LS14	.89	74LS148	1.20	74LS290	1.20
74LS15	.30	74LS151	.75	74LS293	1.79
74LS20	.24	74LS153	.75	74LS295	.99
74LS21	.30	74LS154	1.75	74LS298	.99
74LS22	.24	74LS155	.89	74LS324	1.75
74LS26	.30	74LS156	.89	74LS352	1.49
74LS27	.24	74LS157	.75	74LS353	1.49
74LS28	.24	74LS158	.75	74LS363	1.49
74LS30	.24	74LS160	.95	74LS364	1.95
74LS32	.36	74LS161	.95	74LS365	.89
74LS33	.55	74LS162	.95	74LS366	.89
74LS37	.55	74LS163	.95	74LS367	.69
74LS38	.35	74LS164	.95	74LS368	.69
74LS40	.30	74LS165	.95	74LS373	.99
74LS42	.49	74LS166	1.95	74LS374	1.69
74LS47	.75	74LS168	1.69	74LS377	1.40
74LS48	.75	74LS169	1.69	74LS378	1.15
74LS49	.75	74LS170	1.69	74LS379	1.35
74LS51	.30	74LS173	.75	74LS385	1.89
74LS54	.35	74LS174	.89	74LS386	.59
74LS55	.35	74LS175	.89	74LS390	1.79
74LS63	1.20	74LS181	1.99	74LS393	1.79
74LS73	.39	74LS189	9.50	74LS395	1.59
74LS74	.44	74LS190	.89	74LS399	1.59
74LS75	.49	74LS191	.89	74LS424	2.89
74LS76	.39	74LS192	.89	74LS447	.75
74LS78	.49	74LS193	.89	74LS490	1.89
74LS83	.75	74LS194	.89	74LS668	1.65
74LS85	.95	74LS195	.89	74LS669	1.85
74LS86	.39	74LS196	.79	74LS670	2.10
74LS90	.65	74LS197	.79	74LS674	9.50
74LS91	.79	74LS221	1.10	74LS682	2.99
74LS92	.65	74LS240	.95	74LS683	2.39
74LS93	.59	74LS241	.95	74LS684	2.39
74LS95	.79	74LS242	1.79	74LS685	2.39
74LS96	.79	74LS243	1.79	74LS688	2.39
74LS107	.39	74LS244	.95	74LS689	2.39
74LS109	.39	74LS245	1.89		
74LS112	.39	74LS247	.79	81LS95	1.65
74LS113	.39	74LS248	1.20	81LS96	1.65
74LS114	.49	74LS249	.89	81LS97	1.65
74LS122	.45	74LS251	1.25	81LS98	1.65

### MISC.

#### Disc Controller

1771	18.95
1791	34.95
1793	34.95
1797	49.95

#### Uarts

AY3-1014	5.85
AY5-1013	3.90
AY5-2376	12.00
TR 1602	4.25

#### Interface

8T26	1.65
8T28	1.95
8T95	.95
8T96	.95
8T97	.95
8T98	.95
DM8131	2.90
DS8836	1.25

# (800) 538-8800

ALL MERCHANDISE IS 100% GUARANTEED

### DISKETTES 5 1/4"

ATHANA SS SD Soft	23.95
WABASH SS SD Soft	23.95
VERBATIM SS DD Soft	28.95

### IC Sockets ST W/W

8 PIN	.10	.49
14 PIN	.12	.50
16 PIN	.15	.57
18 PIN	.20	.85
20 PIN	.25	.99
22 PIN	.25	1.30
24 PIN	.25	1.40
28 PIN	.35	1.50
40 PIN	.40	1.80

ST = Soldertail  
W/W = Wirewrap

### CMOS

4000	.25	4071	.30
4001	.30	4072	.30
4002	.30	4073	.30
4006	.90	4075	.30
4007	.25	4076	.90
4008	.90	4078	.30
4009	.45	4081	.30
4010	.45	4082	.30
4011	.30	4085	.90
4012	.30	4086	.90
4013	.45	4093	.90
4014	.90	4098	2.49
4015	.90	4099	1.90
4016	.45	4502	.90
4017	1.15	4503	.60
4018	.90	4508	1.90
4019	.45	4510	.90
4020	.90	4511	.90
4021	.90	4512	.90
4022	1.10	4514	1.20
4023	.35	4515	2.20
4024	.75	4516	1.50
4025	.35	4518	1.20
4026	1.60	4519	1.20
4027	.60	4520	1.20
4028	.75	4522	1.20
4029	.90	4526	1.20
4030	.45	4527	1.90
4034	2.90	4528	1.20
4035	.85	4531	.90
4040	.90	4532	1.90
4041	1.20	4538	1.90
4042	.75	4539	1.90
4043	.75	4543	2.70
4044	.75	4555	.90
4046	.90	4556	.90
4047	.90	4581	1.90
4049	.50	4582	1.90
4050	.50	4584	.90
4015	.90	4585	.90
4053	.90		
4060	1.39	80C07	.90
4066	.75	80C95	.90
4068	.39	80C96	.90
4069	.30	80C97	.90
4070	.35	80C98	1.15

# DoKay Computer Products, Inc.

3250 Keller Street, #9  
Santa Clara, CA 95050  
(800) 538-8800  
Calif. Residents (408) 988-0697

STORE HOURS:  
MON-FRI 8:30 A.M.-6:00 P.M.  
SAT 10:00 A.M.-3:00 P.M.



TERMS: For shipping include \$2.00 for UPS Ground, \$3.00 for UPS Blue Label Air, \$10.00 minimum order. Bay Area residents add 6 1/2% Sales Tax. California residents add 6% Sales Tax. We reserve the right to limit quantities and substitute manufacturer. Prices subject to change without notice. Send SASE for complete list.

# LABELS

# 299

perM

15/16"x3 1/2" white pressure  
1 up - pin feed sensitive

### PRICE INCLUDES SHIPPING

Packed 5M per box - Min. order 1 box - \$14.95  
Check with order - Mass Residents add 5% Sales Tax



## CHECK-MATE™

P.O. Box 103, Randolph, MA 02368

Telephone: 617-963-7694

CALL TOLL FREE 1-800-343-7706

Circle 540 on inquiry card.

## Beautiful Plots with PLOTPAK™

PLOTPAK is a complete plotting library that runs under FORTRAN-80 and includes drivers for the following screens and plotters:

- MicroAngelo MA 512
- ADM + Retrographics
- TEK 4010 compatible terminals
- Houston Instruments DMP-4
- HP plotters 7225B and 7470
- Radio Shack Printer / Plotter

PLOTPAK (.REL file): ..... \$275.

PLOTPAK source code plus two drivers: ..... \$365.



### Computer Company

DIVISION OF Sea Data Corporation

One Bridge Street, Newton, MA 02158

TEL. (617) 244-8190 TLX: 951107

Circle 64 on inquiry card.

## 68000 Systems & TRS-80 Model 16 Database & File Software

relational database system easy to use, powerful, & efficient

menus & English subset query language  
68000 code  
sequential, indexed, & direct files  
(incl. features never seen before such as: always single access on random records, sequential update without rewrite)

multikey  
report generation  
data validation on entry  
repetitive batch update  
multi-existent files  
reentrant code for shared usage  
multiple precision & floating point access security

separate file and sort (core/disk) packages available

Send for catalog

### Data Management Systems

211 N. El Camino Real, IOIC  
Encinitas, CA 92024  
or phone: (714) 942-0744

Circle 144 on inquiry card.



## maxell.

### Floppy Disks

SAVE 40% Write for your complete list.

5 1/4" Specify soft, 10 or 15 sector Price/10

MD1 or MH1 SS/DD ..... \$33  
MD2 or MH2 DS/DD ..... 47  
MD1-DDM SS/QD/96 TP1 ..... 43  
MD2-DDM DS/QD/96 TP1 ..... 53

8" Specify soft or 32 sector

FD1 or FH1 SS/DD ..... 43  
FD2 or FH2 DS/DD ..... 53

CHECKS — VISA — MC — C.O.D.  
(313) 777-7780 ADD \$2 SHIPPING

LYBEN COMPUTER SYSTEMS  
27294 Harper Ave.  
St. Clair Shores, MI 48081

Circle 275 on inquiry card.



A word for this Punch/Reader Combo is .....

.....  
.....  
.....

**Speed!** Model 510 punches paper tape at 110cps, reads at 150cps. This rugged machine is computer compatible offering RS232C, current loop, parallel inputs. The ASCII-to-Baudot code conversion permits direct keyboard entry for Telex/TWX transmission. Plus: 256 character storage, 75-9600 baud rate, 5-8 level tape, stock. ADDMASTER CORP. 416 Junipero Serra Dr., San Gabriel, CA 91776 \* 213/285-1121.

Circle 9 on inquiry card.

## ☆☆ SUPER™ ☆☆ ISA's DATABASE

The only DBMS with all these features:

- ★ PROVEN in one year of test marketing
- ★ TOUGH, reliable file structure
- ★ MENU driven for simplicity and easy use
- ★ ARITHMETIC with stored calculations
- ★ FAST set-up and report formatting
- ★ CLEAR user-oriented documentation
- ★ PRINTS totals & subtotals — mail labels
- ★ REFORMATS and merges data files
- ★ MULTI-DISK files: Up to 128K records
- ★ SORTS file disks on up to 40 fields
- ★ PRODUCTION input of repetitive data
- ★ USE existing data files
- ★ COUPLES to word processors
- ★ POSTS transactions to master file
- ★ SEARCH by strings, ranges, comparisons
- ★ DATA COMPRESSION: Over twice as many labels as the other system

For TRS-80™ Models I, II, III, & 16 — 250.00  
CP/M™ — 295.00

Ask your Dealer or Write:

Institute for Scientific Analysis, Inc.  
P. O. Box 7186, Dept. B-2  
Wilmington, DE 19803 (215) 358-3735

\*T.M. Tandy Corp. †T.M. Digital Research

Circle 234 on inquiry card.



## MORROW DESIGNS DECISION 1

FACTORY LIST \$5295 W-5 MEG HD  
DEALER COST 3812 \$3795 & 5 1/4" D500  
QUANTITY 3 FLOPPY DISK

First time computer users add \$750 to all prices. Cue Warranty, & Factory Warranty  
CALL US 9 AM to 10 PM PM (Central & Pacific)

Decision 1, 14 Slot 5-MEG, 2-80, 80K Static, 1 to 18 users (Need more memory, Software  
& HD for 18 users) Desk top, with CP/M™, Wordstar™ & Microsoft Basic™, 3 Sectors & 1  
Parallel port. Built-Disk controller DMA, all floppy disks are double density

	Qty @ Retail	Your Price
D1 Computer Only, no Disk	\$2395	\$1899
D2 With Two 5 1/4" D500 Floppy Disk	3495	2695
D3A With One 5 Meg HD & One 5 1/4" D500	\$295	\$469
D3C With One 10 Meg HD & One 5 1/4" D500	7795	\$775
Hard Mount, Discs 1, 19, 2, 25 & 6.5 80 Lbs. 12 Slot M/B 8" Hard and & Floppy disks. Otherwise as above		
R2A With One 10 Meg HD & One 8" D500	6895	\$149
R2B With One 10 Meg HD & One 8" D500	7195	\$469
R2C With One 20 Meg HD & One 8" D500	7795	\$775
R2D With One 20 Meg HD & One 8" D500	8095	\$195

5 1/4" Winchester Hard Disk with DMA controller, power supply, cabinet,  
for CP/M 2.2, and Microsoft Basic 80

3 Meg formatted Hard Disk 2195 1749  
10 Meg formatted Hard Disk 2795 2195  
16 Meg formatted Hard Disk 3795 2895

TERMS: All prices are net to dealer and include cash discount. Certified  
check, M.O. & bank transfer accepted same as cash. Add 3% for other forms.

Apple II users for personal check to clear 15% restocking or 10% cancelation  
charge. Add 2% handling and freight to and from Ala. & residents add  
sales tax. CALL US for exact calculation of your net price.

Process subject to change, mostly downward

CALL US 9 AM to 10 PM

205 879-5976

205 879-4735

## CostPlus COMPUTERS

OF ALABAMA

P.O. Box 6114-Birmingham, AL 35259-6114

Circle 271 on inquiry card.

## 28K

### Commodore VIC Computer (60% more powerful than VIC-20)

# \$299

## SPECIAL SALE PRICE

We add 60% more programming power to the VIC-20 computer! This gives you a full sized extra featured computer with 20,000 bytes ROM, 16K extended level II BASIC, 8000 bytes RAM, that expands to 80K total memory! 66 typewriter keyboard, graphics keys, 16 colors, sound, music, real time, upper/lowercase, full screen editing! \$109 modem, printer, disks, cassette plugs in direct. We have over 400 programs! 90 day immediate replacement warranty! One day express mail delivery! Write for free catalog!

15 DAY FREE TRIAL - IMMEDIATE REFUNDS

### PROTECTO ENTERPRIZES

BOX 550  
BARRINGTON, IL 60010  
PHONE ORDERS 312/382-5244

Circle 388 on inquiry card.

## ATARI

VIC-20	\$239
800 COMPUTER (16K)	\$635.00
800 COMPUTER (48K)	\$724.00
400 COMPUTER (16K)	\$265.00
410 PROGRAM RECORDER	\$74.00
810 DISK DRIVE	\$429.00
NEC 8023A-C PRINTER	\$475.00
PERCOM D/D DISK DRIVE	\$589.00

AXIOM 6P, 100 PFR	\$299.95	AZIMM (IMP-4) PFR	\$489.95
ENTERTAINER	\$58.95	32K RAM (INTEC)	\$39.95
EDUCATOR	\$114.95	32K RAM (MICROTEK)	\$39.95
PROGRAMMER	\$52.00	32K RAM (MOSMIC)	\$118.95
COMMUNICATOR	\$299.00	48K RAM (INTEC)	\$189.95
BOOKKEEPER (KIT)	\$169.95	TYPE 'N' TALK	\$319.00

### ATARI SOFTWARE

Maths Action & Editor	\$49.95	AmigaQuest	\$24.95
Microsoft Basic (D)	\$67.95	Letter Perfect (D)	\$49.95
Mac Math II	\$12.95	Hi RES (D) & Address (D)	\$23.95
Compendium (F)	\$12.95	Hi RES (K) & Address (K)	\$23.95
Assault on Earth (R)	\$44.95	Circle (C)	\$39.95
Chess (C) & Chess (K)	\$29.95	Circle (K)	\$34.95
Invaders (D) (C)	\$29.95	Survival Adventure (D)	\$17.95
Star Wars (D)	\$29.95	Atcham Quest (C)	\$29.95
Warrior (D)	\$17.95	Bus Attack (D)	\$29.95
Yin-Yang (D)	\$19.95	Hi-Razy Shootout (R)	\$39.95

D = DISK C = CASSETTE R = ROM (CARTRIDGE)

WRITE FOR FREE CATALOG  
(\$2 Shipping per software order. Hardware  
Shipping call for rates. Call numbers add 6%  
sales tax. Atari is a trademark of Atari, Inc.

ORDER LINES OPEN  
SEVEN DAYS 8 am - 9 pm

Circle 134 on inquiry card.

# We Have It!.. At the best prices.

**Call For Super Value  
On S-100 System With  
Dbl. Dens. 8"Drives!**

## INTERTEC SUPERBRAIN II Free! MicroSoft Basic 80

Self-contained computer with dual disks and two RS232C ports. Complete with CP/M 2.2.

64K Double Density.....	\$2099
64K Quad Density.....	\$2495
64K Super Density.....	\$2949
10 Meg. DDS Hard Disk.....	\$2995

## VIDEO TERMINALS

INTERTEC INTERTUBE II.....	749
ZENITH Z-19.....	729
SOROC IQ 120.....	649
SOROC IQ 130.....	595
SOROC IQ 135.....	749
SOROC IQ 135G.....	799
SOROC IQ 140.....	1149
HAZELTINE ESPRIT.....	CALL
1420.....	CALL
1500.....	CALL
1510.....	CALL
1520.....	CALL
TELEVIDEO 910C.....	CALL
912C.....	CALL
920C.....	CALL
925C.....	CALL
950C.....	CALL
TEXAS INST. 940 BASIC.....	1599
940 Package.....	2079
745 Portable Terminal.....	1399
745 Portable Terminal w/U/L/Case.....	1495

## PRINTERS

ANADEX DP-9500.....	\$1349
DP-9501.....	1349
PAPER TIGER IDS-560G.....	1139
PRISM PRINTER IDS-80, w/o color.....	Call
IDS-80, w/color.....	Call
IDS-132, w/color.....	1695
NEC 3510, RO RS232C 35 CPS.....	1945
NEC 3530, RO, Centr. Inter. 35CPS.....	1945
NEC 7710, RO RS232C 55 CPS.....	2395
NEC 7720, KSR, RS232C 55CPS.....	2999
NEC 7730, RO, Centr. Inter. 55 CPS.....	2395
QUME	
Sprint 9/45, LTD, 45 CPS, RS232C.....	2119
C.I.TOH Pro Writer, Parallel.....	549
Serial and Parallel.....	629
DIABLO 630, RS232C, 55 CPS.....	2299
CENTRONICS 730-1, Parallel.....	399
730-3, RS232C.....	489
739-1 w/ Graphics, Parallel.....	525
739-3B w/ Graphics, RS232C.....	639
704-11, Parallel.....	1695
704-9, RS232C.....	1595
122G, Parallel, 120 CPS.....	949
EPSON	
MX80.....	489
MX80FT.....	589
MX100FT.....	789
RS232 Serial Interface.....	65
RS232/2K BufferInterface.....	125
Graftrax II.....	90
Apple Printer Interface.....	75
T1810 Basic, RS232C.....	1349
810 Basic, RS232C & Parallel.....	1395
810 w/full ASCII, vertical forms control compressed print.....	1599
820 RO, Basic.....	1645
820 KSR, Basic.....	1839

OKIDATA	
Microline 80.....	\$465
Tractor-feed option.....	59
Microline 82A.....	519
Microline 83A.....	849
Microline 84.....	1199

## MONITORS

ZENITH-ZYM-121, 12" Green Phos.....	\$125
AMDEK 100, 12".....	139
100G, 12" Green Phosphor.....	149
300, 12" Green Phos., Hi. Res.....	199
Color, 13".....	359
Color II, 13", R.G.B. Hi Res.....	799
Apple adapt. for R.G.B.....	159
BMC, 12", Green Phosphor.....	169

**NORTH STAR  
Call For Prices**

## FLOPPY DISK SYSTEMS

MORROW DESIGNS	
Discus 2D, single drive DD.....	\$898*
Dual Discus 2D, dual drive DD.....	1549*
Discus 2+2, double sided DD.....	1239*
Dual Discus 2+2.....	2139
*Includes CP/M 2+2 and Microsoft Basic	

## HARD DISK SUBSYSTEMS

MORROW DESIGNS	
Discus M-5 5 Meg.....	\$1849*
Discus M-10 10 Meg.....	3095*
Discus M-20 20 Meg.....	4069*
Discus M-26, 26 Meg.....	3795*
CORVUS 5 Meg.....	3185
10 Meg.....	4545
20 Meg.....	5499
KONAN David 5 Meg.....	2499
10 Meg.....	3049
15 Meg.....	3295
INTERTEC 10 Meg.....	SPECIAL \$3195
*S 100 only w/CP/M 2+2 & Microsoft Basic	

## FLOPPY DISK CONTROLLER BOARDS

CROMEMCO 16FDC DD.....	\$499
NORTH STAR DD.....	479
MORROW Disk Jockey 2D, A&T.....	329
SD SYS. Versafloppy I, A&T.....	319
SD SYS. Versafloppy II, A&T.....	429
DELTA DD Disk Cont., A&T.....	345
CONDUCTOR DD, A&T.....	269
INTERSYSTEMS, FDC-2, A&T.....	439
TARBELL DD, A&T.....	445
SYSTEMS GROUP DD DMA.....	439

## ESCON CONVERSION FOR IBM SELECTRIC

Complete with microprocessor controller and power supply. Factory built. User installs solenoid assembly or it can be done at ESCON Factory.	
RS232 Serial & Parallel.....	\$534
Cable for above.....	25

## PROM PROGRAMMERS

SSM PB1 Kit.....	\$152
SSM PB1, A&T.....	225

## MODEMS

NOVATION CAT Acoustic Modem.....	\$149
D-CAT Direct Connect.....	155
AUTO-CAT Auto Ans.....	219
APPLE CAT.....	329
USD 103 LP Direct Connect.....	175
103 JLP Auto Answer.....	209
DC HAYES MICROMODEM II (Apple).....	299
MODEM 100 (S 100).....	339
Smart Modem (RS 232).....	239
Potomac Micro Magic (S 100).....	339

## CALIFORNIA COMPUTER SYSTEMS

Z80 CPU Board.....	\$269
Disk Controller 2422, w/CP/M.....	359
16K Static, A&T.....	259
32K Static, A&T.....	399
64K Dynamic RAM.....	335
System 2210 w/64K, CP/M 2.2.....	1495

## CPU BOARDS

(assembled unless noted)

NORTHSTAR Z-80A (ZPB-A/A).....	\$269
INTERSYSTEMS (MPU-80).....	349
SSM CB1 8080, A&T.....	214
CB2, Z-80, A&T.....	289
CB2, Z-80, Kit.....	219
DELTA Z-80 with I/O.....	289
SD SYSTEMS, SBC-100, A&T.....	349
SBC-200, A&T.....	399
SYSTEMS GROUP Z 80 with I/O.....	419

## MEMORY BOARDS

NORTHSTAR 16K RAM.....	\$299
HRAM 64K.....	589
HRAM 32K.....	419
CROMEMCO 16KZ.....	419
CROMEMCO 64KZ.....	595
MEMORY MERCHANT	
16K Static, 4MHz.....	159
64K Static, 4MHz.....	549
SYSTEMS GROUP	
(Measurement Systems & Controls)	
DM4800 48K Board.....	499
DM6400 64K Board.....	529
DMB6400 64K Board.....	595
INTERSYSTEMS 64K Dynamic.....	845

## GODBOUT (A&T)

CPU Z.....	\$249
CPU 8085 88.....	359
RAM 20 30.....	359
RAM 17 64.....	675
RAM 21.....	1439
Interface 1.....	210
Interface 2.....	210
Disk 1.....	419
System Support 1.....	335
Enclosure 2 (Desk).....	699
Enclosure 2 (Rack).....	760

## VIDEO BOARDS I/O Mapped

SD SYSTEMS	
VDB-8024, A&T.....	\$469
SSM VB2 I/O, Kit.....	169
VB2 I/O, A&T.....	229
MEMORY MAPPED	
VB1C, 16x64, Kit.....	152
VB1C, 16x64, A&T.....	206
VB3, 80 Char. 4MHz, Kit.....	359
VB3, 80 Char. 4MHz, A&T.....	419

## APPLE BOARDS

CALIFORNIA COMPUTER	
7710A Asynchronous Ser Interface.....	\$129
7712A Synchronous Der Interface.....	149
7424A Calendar Clock.....	99
7728A Centronics Printer Interface.....	99

## MOUNTAIN HARDWARE

CPS Multifunction Board.....	\$199
Supertalker SD200.....	259
Romplus w/ keyboard filter.....	179
Romplus w/o keyboard filter.....	130
Keyboard filter ROM.....	49
COPYROM.....	49
Music System.....	459
ROMWRITER.....	149
Apple Clock.....	239
A/D-D/A.....	295
Expansion Chassis.....	625
VISTA	
8" Disk Controller (Apple II).....	\$495

All prices, F.O.B. shipping point, subject to change. All offers subject to withdrawal without notice. Advertised prices reflect a 2% cash discount (order prepaid prior to shipment). C.O.D.'s and credits cards are 2% higher.

# MiniMicroMart, Inc.

943 W. Genesee St. P.O. Box 2991B Syracuse, N.Y. 13220 (315) 422-4467 TWX 710-542-0431

## WANT HELP?

### COBOL PROGRAMMER'S AIDE (CPA)

Provides extensive assistance in **COOING, DEBUGGING, MAINTAINING** and **DOCUMENTING** your Cobol programs - Improve your efficiency and productivity - **EASY TO USE - MENU DRIVEN - A PRACTICAL SET of TOOLS - An INVALUABLE AIDE.**

CPA features:

- SOURCE ANALYZER & CROSS REFERENCE
- SOURCE EDITOR & REFORMATTER
- SOURCE OVERVIEWER
- DOCUMENTATION PRINTER
- PARAMETER FETCHER SUB-PROGRAM
- COMPREHENSIVE MANUAL and more

Available for CP/M<sup>®</sup>, CDOS<sup>®</sup> or CROMIX<sup>®</sup> users utilizing COBOL-80<sup>®</sup> or Cromemco Cobol

Satisfaction guaranteed or full refund!

For Program Samples and information call or write:

**Automated Programming Methods, Inc.**  
2212 Dupont Dr.,  
Irvine, CA 92715  
(714) 851-8686

Trademarks: <sup>®</sup>MicroSoft, <sup>®</sup>Digital Research, <sup>®</sup>Cromemco

## Now...You Can Monitor 7 Most Important RS-232 Interface Lines



Made in America

### RS-232-INTERFACE TESTER

connects in series with any RS-232 Interface LED's clearly display status of 7 functions: transmit data, receive data, request to send, clear to send, data set ready, carrier detect, data terminal ready. Requires no power, may be left in permanently. Satisfaction guaranteed **ORDER NOW!** Only \$39.95. Purchase Orders from rated Corps accepted. **FREE** illustrated catalog of problem detecting equipment. We also do custom design work. 815/539-5827.

**B & B electronics**  
Box 475-EDN, MENDOTA, IL 61342

Circle 46 on inquiry card.

## TRACK YOUR OWN PORTFOLIOS

by using the  
**PROGRAM OF THE  
SECURITY PROFESSIONALS**

This Portfolio management System Has:  
Capacity: 10 Portfolios 1500 Transactions

Capability: • Portfolio Evaluation  
• Profit/Loss Statement  
Short-Term Long-Term  
Realized Unrealized  
• Total Position  
Open & Closed  
• Handles Stocks, Bonds, Options  
• Handles Splits and Stock Dividends

Configuration: Requires—  
Apple II Plus Computer  
Apple Language Card  
Two 5 1/4" Disk Drives  
Printer—Will Run On 3 Printers—  
Epson MX80/100/  
Qume Letter Quality/  
Nec Dot Matrix

Cost: \$100 (N.C. residents add 4% sales tax)  
mail check to:

**BROKERSOFT, INC.**  
Post Office Box 1762  
Wilmington, N.C. 28402

\*Also available with 100 or 2500 portfolios as The \$2 Broker™ for  
Brokers, Security Analysis, Investment Advisors and Traders.  
The \$2 Broker is a trademark of BROKERSOFT, INC.

Circle 86 on Inquiry card.

## MULTI-USERS

- Do several persons use your system?
- Do you have information you'd rather not have everyone see?

MicroCrypt<sup>™</sup> will encrypt your files quickly and easily with any password you choose. No lengthy key generation process. No long encryption or decryption process.

Use for letters, salary schedules, key documents, or programs. Can even call from dBase II<sup>®</sup> to keep your data bases private.

**MicroCrypt<sup>™</sup>: \$125.00** Disk and Manual  
Requires CP/M<sup>®</sup> or MP/M<sup>®</sup> Z80/8080

**Order Line: 800-368-3359**

From the MicroShell<sup>™</sup> developers.



2153 Golf Course Dr.  
Reston, Va 22091  
(703) 476-9143  
VISA/MC/COD  
Foreign Add \$10.00 Air Mail

TM <sup>®</sup>Ashton-Tate <sup>®</sup>Digital Research

Circle 123 on inquiry card.

## WMS IMPERIAL MICRO SUPPLY LTD.

### Scotch<sup>®</sup> DISKETTES



#### DISKS SCOTCH 3M

5 1/4" ..... \$2.30 each  
Reinforced Hubs. Any Quantity  
Save more on 100 or more boxes \$2.25 ea.

#### MEMORY

RAM  
4116-200NS ..... 8/16  
4164-200NS ..... \$10 each  
EPROMS  
2716 (5V) ..... \$5.50 each  
X-TALS MHZ ..... \$2.25 each  
1.0 3.579545 5.0688 10.0 18.0  
2.0 4.0 5.7143 14.31818 20.00  
3.0 5.0 8.0 16.0

**WMS IMPERIAL MICRO SUPPLY LTD.**  
P.O. BOX 811 DEPT. M, PONTIAC, MI 48054  
Please add \$2.00 Shipping — Michigan add 4% Tax

Circle 229 on inquiry card.

**New** Available from Hytor —  
for  
Color Computer Disc System  
owners.

A software development  
system for only **\$60.00**  
includes 6809 Assembler  
Program Editor Loader  
and Memory Dump.

*Unleash the power of  
your Color Computer  
now.*

**Write or Call Today!**

## HYTOR INC.

P.O. Box 4996  
Scottsdale, Az. 85261  
(602) 863-3122

Circle 224 on Inquiry card.

## BREAKTHROUGH

Originate/Answer UDS 212 LP Modem

~~\$495~~

\$420



#### IMMEDIATE DELIVERY

- Compatible with Bell 212 modems (1200 bps only)
- Telex powered — no AC connection required
- Simplified controls — talk/data and originate/answer only
- Direct-connect to dial-up network

## INTERBUSINESS CORP.

1111 W. Dundee Road  
Wheeling, IL 60090  
Sales—(312) 459-8986  
Service—(312) 459-8874

Circle 242 on Inquiry card.



## IPEX

**NEW!**

"ELF" Interface  
Converts Your  
Typewriter Into Printer



- Finest print quality
- Low cost
- Easy Installation
- Quick delivery
- Fits IBM Selectric<sup>®</sup> and Electronic Typewriters
- Models for all popular computers
- Call or write for more information, today!

**IPEX** INTERNATIONAL INC.  
5115 Douglas Fir Rd.  
Calabasas, CA 91302 U.S.A.  
Tel: (213) 710-1444 TLX/TWX: 910 494 2100

Circle 247 on inquiry card.

## Verbatim flexible disks

Call Free (800) 235-4137 for  
prices and information. Dealer  
inquiries invited. C.O.D. and  
charge cards accepted.

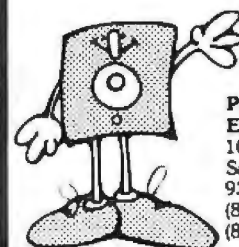

VISA

**PACIFIC EXCHANGES**  
100 Foothill Blvd.  
San Luis Obispo, CA  
93401. In Cal. call  
(800) 592-5935 or  
(805) 543-1037

Circle 358 on Inquiry card.

# Why use their flexible discs:

BASF, Control Data, Dysan, IBM, Kybe, Maxell, Nashua, Scotch, Syncom, Verbatim or Wabash  
when you could be using

# MEMOREX

## high quality error free discs?

Product Description	Part #	CE quant. 100 price per disc (\$)
8" SSSD IBM Compatible (128 B/S, 26 Sectors)	3062	2.09
8" SSSD Shugart Compatible, 32 Hard Sector	3015	2.09
8" SSSD CPT 8000 Compatible, Soft Sector	3045	2.99
8" SSDD IBM Compatible (128 B/S, 26 Sectors)	3090	2.74
8" DSDD Soft Sector (Unformatted)	3102	3.34
8" DSDD Soft Sector (128 B/S, 26 Sectors)	3115	3.34
8" DSDD Soft Sector (256 B/S, 26 Sectors)	3103	3.34
8" DSDD Soft Sector (512 B/S, 15 Sectors)	3114	3.34
8" DSDD Soft Sector (1024 B/S, 8 Sectors)	3104	3.34
5 1/4" SSDD Soft Sector w/Hub Ring	3481	2.34
5 1/4" SSDD 10 Hard Sector w/Hub Ring	3483	2.34
5 1/4" SSDD 16 Hard Sector w/Hub Ring	3485	2.34
5 1/4" DSDD Soft Sector w/Hub Ring	3491	3.09
5 1/4" DSDD 10 Hard Sector w/Hub Ring	3493	3.09
5 1/4" DSDD 16 Hard Sector w/Hub Ring	3495	3.09
5 1/4" SSDD Soft Sector w/Hub Ring (96 TPI)	3504	2.99
5 1/4" DSDD Soft Sector w/Hub Ring (96 TPI)	3501	3.99

SSSD = Single Sided Single Density; SSDD = Single Sided Double Density  
DSDD = Double Sided Double Density; TPI = Tracks per inch

### Memorex Flexible Discs... The Ultimate in Memory Excellence

**Free Memorex Mini-Disc Offer - Save 10%**  
Every carton of 10 Memorex 5 1/4 inch mini-discs sold by Communications Electronics, now has a coupon good for a free Memorex mini-disc. For every case of 100 Memorex mini-discs you buy from CE, you'll get 10 free mini-discs directly from Memorex. There is no limit to the number of discs you can purchase on this special offer. This offer is good only in the U.S.A. and ends on December 31, 1982.

**Quality**  
Memorex means quality products that you can depend on. Quality control at Memorex means starting with the best materials available and continual surveillance throughout the entire manufacturing process. The benefit of Memorex's years of experience in magnetic media production, resulting, for instance, in proprietary coating formulations. The most sophisticated testing procedures you'll find anywhere in the business.

**100 Percent Error Free**  
Each and every Memorex Flexible Disc is certified to be 100 percent error free. Each track of each flexible disc is tested, individually, to Memorex's stringent standards of excellence. They test signal amplitude, resolution, low-pass modulation, overwrite, missing pulse error and extra pulse error. Rigid quality audits are built into every step of the manufacturing process and stringent testing result in a standard of excellence that assures you, our customer, of a quality product designed for increased reliability and consistent top performance.

**Customer-Oriented Packaging**  
The desk-top box containing ten discs is convenient for filing and storage. Both box labels and jacket labels provide full information on compatibility, density, sectoring, and record length. Envelopes with multi-language care and handling instructions and and color-coded removable labels are included. A write-protect feature is available to provide data security.

**Full One Year Warranty—Your Assurance of Quality**  
Memorex Flexible Discs will be replaced free of charge by Memorex if they are found to be defective in materials or workmanship within one year of the date of purchase. Other than replacement, Memorex will not be responsible for any damages or losses (including consequential damages) caused by the use of Memorex Flexible Discs.

**Quantity Discounts Available**  
Memorex Flexible Discs are packed 10 discs to a carton and 10 cartons to a case. Please order only in increments of 100 units for quantity 100 pricing. We are also willing to accommodate your smaller orders. Quantities less than 100 units are available in increments of 10 units at a 10% surcharge. Quantity discounts are also available. Order 500 or more discs at the same time and deduct 1%; 1,000 or more saves you 2%; 2,000 or more saves you 3%; 5,000 or more saves you 4%; 10,000 or more saves you 5%; 25,000 or more saves you 6%; 50,000 or more saves you 7% and 100,000 or more discs earns you an 8% discount off our super low quantity 100 price. Almost all Memorex Flexible Discs are immediately available from CE. Our warehouse facilities are equipped to help us get you the quality product you need, when you need it. If you need further assistance to find the flexible disc that's right for you, call the Memorex compatibility hotline. Dial toll-free 800-538-8080 and ask for the flexible disc hotline extension 0997. In California dial 800-672-3525 extension 0997. Outside the U.S.A. dial 408-987-0997.

**Buy with Confidence**  
To get the fastest delivery from CE of your Memorex Flexible Discs, send or phone your order directly to our Computer Products Division. Be sure to calculate your price using the CE prices in this ad. Michigan residents please add 4% sales tax. Written purchase orders are accepted from approved government agencies and most well rated firms at a 30% surcharge for net 30 billing. All sales are subject to availability, acceptance and verification. All sales are final. Prices, terms and specifications are subject to change without notice. Out of stock items will be placed on backorder automatically unless CE is instructed differently. Minimum prepaid order \$50.00. Minimum purchase order \$200.00. International orders are invited with a \$20.00 surcharge for special handling in addition to shipping charges. All shipments are F.O.B. Ann Arbor, Michigan. No COD's please. Non-certified and foreign checks require bank clearance.

Mail orders to: Communications Electronics, Box 1002, Ann Arbor, Michigan 48106 U.S.A. Add \$8.00 per case or partial-case of 100 8-inch discs or \$8.00 per case or partial case of 100 5 1/4-inch mini-discs for U.P.S. ground shipping and handling in the continental U.S.A. If you have a Master Card or Visa card, you may call anytime and place a credit card order. Order toll-free in the U.S. Dial 800-521-4414. If you are outside the U.S. or in Michigan, dial 313-994-4444. Order your high quality, error free Memorex discs today.

Copyright © 1982 Communications Electronics

Ad #051782

## Free disc offer Save 10%



**Order Toll-Free!**  
**(800) 521-4414**  
In Michigan (313) 994-4444

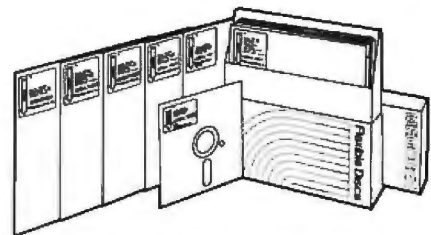

For Data Reliability—Memorex Flexible Discs

**COMMUNICATIONS  
ELECTRONICS™**

**Computer Products Division**

854 Phoenix □ Box 1002 □ Ann Arbor, Michigan 48106 U.S.A.  
Call TOLL-FREE (800) 521-4414 or outside U.S.A. (313) 994-4444

# Votrax SC-01A SPEECH SYNTHESIZER



\$70 Each  
(5 or more,  
\$55 each)

## Order in Ones or Thousands

The SC-01A Speech Synthesizer is a completely self-contained solid state device. This single chip phonetically synthesizes continuous speech of unlimited vocabulary.

The SC-01A contains 64 different phonemes which are accessed by a 6-bit code. Computer interfaces and text-to-speech algorithms also available for product development.

Votrax is a trademark of Federal Screw Works

Call 1-800-645-3479, in N.Y. 1-516-374-6793

MICROMINT INC.

917 Midway  
Woodmere, N.Y. 11598



Call for  
quantity pricing.



Circle 246 on inquiry card.

NEW FULLY COMPILED VERSION

**A-STAT**

**A STATISTICAL ANALYSIS  
AND FILE MAINTENANCE SYSTEM  
FOR THE APPLE II® MICROCOMPUTER**

As a Subset Language of P-STAT™ 78  
A-STAT™ 79 computes

**FREQUENCIES**  
**BI-VARIATE TABLES**  
**CHI SQUARE and 14 MEASURES OF ASSOCIATION**  
**ANALYSIS OF VARIANCE**  
**CORRELATION MATRICES**  
**MULTIPLE REGRESSION**  
**RESIDUALS**  
**APPLE PLOT INTERFACE**  
**APPLE FILE CABINET INTERFACE**  
**FILE SORT**  
**AGGREGATION**  
**REPORT WRITING**  
**COMPLETE TRANSFORMATION LANGUAGE**  
**READS VISICALC FILES**

A-STAT™ 79  
Uses Standard DOS Text File and EXEC's  
Capacity up to 100,000 Data Points per File  
48K Version — All programs in AppleSoft™  
Now Fully Compiled at no additional cost

A-STAT™ 79 is available from  
**ROSEN GRANDON ASSOCIATES**  
7807 Whittier Street  
Tampa, Florida 33617  
(813) 988-4811

A-STAT™ 79 on disk with 100-page manual \$175.00  
Apple II is a trademark of the Computer Inc.  
P-STAT™ 78 is a trademark of A-STAT INC. Princeton, N.J.  
A-STAT™ 79 is copyrighted by Gary M. Rosen, Ph.D.

Circle 410 on inquiry card.

## SUPER SALE

### EPROM's

	1-7	8 up	50 up
2716 (5V, 450nS)	\$3.95	\$3.55	CALL
2732 (5V, 450nS)	7.85	6.95	CALL
2532 (5V, 450nS)	8.25	7.95	CALL

### STATIC RAM

6116P-3 (150nS)	7.50	7.20	CALL
2114L-2 (200nS)	2.10	1.70	CALL

### DYNAMIC RAM

4184 (200nS)	7.90	7.49	CALL
--------------	------	------	------

### MISC

CPU Z80A	\$5.29 ea
CDP-1854ACE (UART)	\$5.29 ea.
16K RAM Expansion Kit for TRS-80 Mod III	\$12.95/8

**SUNTRONICS CO., INC.**  
12621 CRENSHAW BOULEVARD  
HAWTHORNE CALIFORNIA 90250

STORE HOURS: Mon-Fri 9:00am-5:00pm, Sat 10am-4pm  
IN CALIFORNIA OUTSIDE CALIFORNIA TOLL FREE  
**(213) 644-1149 1-800-421-5775**  
Min Order: \$10. P/H: \$2. Accept VISA, Mastercard, Check or M.O.

Circle 528 on inquiry card.

## VIDEO OUTPUT for H/Z '19 or '89

Display the CRT image on  
Projection TV or other  
monitor. Great for classroom  
or group applications.

Only \$79.00

## MAGNOLIA MICROSYSTEMS

2264 - 15th AVE W • SEATTLE, WA 98119  
(206) 285-7266 (800) 426-2841

Circle 279 on inquiry card.

## MEMOREX Flexible Discs

SAVE 40% Write for your complete list.

5 1/4"	Specify soft, 10 or 18 sector	Price/10
1 Side, double density	.....	\$24.70
2 Sides, double density	.....	36.40
1 Side, 80 track, double density	.....	32.50
2 Sides, 80 track, double density	.....	44.20
<small>(All 5 1/4" have Hub-rings)</small>		
8"	Specify soft or 32 sector	
1 Side, single density	.....	23.40
1 Side, double density	.....	30.60
2 Sides, double density	.....	35.80

CHECKS — VISA — MC — C.O.D.  
(313) 777-7780 ADD \$2 SHIPPING

LYBEN COMPUTER SYSTEMS  
27204 Harper Ave.  
St. Clair Shores, MI 48081

Circle 278 on inquiry card.

SIGMA TEK INTERNATIONAL CORPORATION  
327 Clarkin Ct., Walnut Creek, CA 94598  
(415) 838-5097

<b>MICROPROCESSOR CRYSTALS (MHz)</b>			
1 000	1 200	1 600	1 800
2 000	2 097/152	2 457.6	2 808
3 276.0	3 578/45	4 000	4 194/304
4 915.7	5 000	5 006.0	5 185
6 000	6 144	6 400	6 563.6
7 372.0	8 000	10 000	11 000
14 318.0	15 275	18 000	18 432
18 688.0	20 000	22 118.4	32 000
<b>TUNING FORK CRYSTALS (3 x 8 Milibar)</b>			
32 KHz	50 KHz	1.50 each	
<b>EPROMS</b>			
2532 15V 450 nS		8.00 each	
2732 15V 450 nS		7.50 each	
2764 15V 450 nS		14.00 each	
<b>DYNAMIC RAMS</b>			
4164 (150 nS)		10.00 each	

**BOOKS PUBLISHED BY HAYDEN, OSBORNE/MCGRAW-HILL, SAMS, SYBEX**  
15% off list price. Please add \$1.00 for each book for 4th class delivery.  
Minimum order \$10.00. For shipping include \$2.00 for UPS ground \$3.00 for UPS Blue Label Air. California residents add sales tax.

Circle 426 on inquiry card.

## NEW SOFTWARE FROM Single SOURCE Solution™

DEALER INQUIRIES ENCOURAGED

Over 100 innovative low cost programs never before offered for CP/M, TRS-80, IBM-PC, North Star, T199/4A, Apple computers.

Send \$2. for detailed catalog  
(refundable on first purchase)

to **Single SOURCE Solution**  
P.O. Box 578, Concord, CA 94522

Circle 427 on inquiry card.

## 6800 Micro Modules

**FOR INTERFACING TO:** sensors, transducers, analog signals, solenoids, relays, lamps, pumps, AC motors, DC motors, stepper motors, keyboards, displays, 488 GPIB.

**ADDITIONAL FEATURES:** 6800 MPU, counter/timer, fail safe battery back up

Wintek Corp.  
1801 South Street  
Lafayette, IN 47904  
317 747-8425

Circle 491 on inquiry card.

## SOFTSPOOL®

The Software Spooler Program for the IBM PC®

- Spools data to printer in background while executing any program
- MSDOS 1.0 and 1.1 compatible
- Easy to use—(can be invoked automatically at power-up)
- Operation transparent to user
- Program execution no longer linked to printer speed
- Spool buffer sizes user modifiable
- Requires minimum 48K w/disk
- Greatly increases productivity
- Ideal for business or software development
- Requires NO additional hardware
- 30 Day money back guarantee

Price: \$49.95\*\* (includes disk & documentation)  
Dealer and Distributor Prices on Request  
FOR ORDERS CALL—(617) 682-0856

**OR SEND CHECK TO:** MC and VISA  
Rickerdata accepted  
P.O. BOX 288  
Burlington, MA 01803

- Registered Trademark Rickerdata
- Registered Trademark IBM
- \*\* Mass. Residents add 5% Sales Tax

Circle 529 on inquiry card.

### FLOPPY DISK DRIVES



**SPECIAL!!!!!! QUME DATATRAK 8**  
Virtually the industry standard. High quality/reliability. Full featured, double sided, double density.

Tandon TM 848 . . . . . \$545  
\$525 quantity 1, \$499 quantity 2 up.

#### TANDON DOUBLE SIDED, DOUBLE DENSITY MINIS

TM100-2 . . . . 48 TPI (500 KBYTES) . . . . . \$325  
Compatible with Northstar, Cromemco, TRS-80

TM100-4 . . . . 96 TPI (1000 KBYTES) . . . . . \$425  
Compatible with Zenith, Heath, etc.

#### TANDON 5 1/4" HARD DISKS

TM 602 (5MB) . . . . . \$1195  
TM 603 (10MB) . . . . . \$1295

### CONTROLLERS

Tarbell single density kit . . . . . \$195  
Tarbell single density A & T . . . . . \$310  
Tarbell double density A & T . . . . . \$425  
CCS 2422 w/CPM 2.2 . . . . . \$350  
Godbout Disk 1 . . . . . \$450  
MDA MXV-21 LSI-11 controller (RX-01, RX-02 compatible) . . . . . \$1050

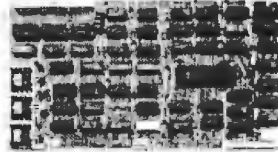

### MISCELLANEOUS

2 Disk drive enclosure . . . . . \$ 95  
(fits Siemens, Shugart, Qume)  
CP-206 power supply . . . . . \$110  
(powers two floppies)

Mini-Enclosure with power supply  
1 drive . . . . . \$ 85  
2 drives . . . . . \$120

Cable Kits 2 drives . . . . . \$ 35  
3 drives . . . . . \$ 40  
4 drives . . . . . \$ 45  
Diskettes ss \$39/10 - ds \$59/10

### CPU

CCS 2810 . . . . . \$ 275  
Godbout Z-80A . . . . . \$ 275  
Godbout 8085A . . . . . \$ 295

### MEMORY

CCS 2065 64K dynamic . . . . . \$ 595  
CCS 2116 32K static . . . . . \$ 625  
Godbout RAM 17 64K . . . . . \$ 675

### I/O

CCS 2710 4 SIO . . . . . \$ 325  
Godbout Interfacer 1 . . . . . \$ 225  
Godbout Interfacer 2 . . . . . \$ 225

### NEW !!!!

**Qume Sprint 9**  
**DAISY WHEEL PRINTER . . \$2395**

45 CPS, RO. Available in KSR version.  
Call for further particulars.  
Ribbons: \$125/case  
Bidirectional tractor feed \$225

### NEW !!!!

**ABM 85 Video Terminal . . \$ 895**

- Detachable keyboard
- Teletype 920, ADM 3A compatible
- High resolution green phosphor (23 MHZ)
- Extra multi-bus or S-100 slot for stand-alone capability

Terms of sale: cash or checks, MC/VISA. Min. order \$25. CA residents add 6% tax. Prices subject to change without notice. All goods subject to prior sale.

## Electrolabs

POB 1608, Palo Alto, CA 94302 (415) 965-7040

## SUNNY LOW LOW COST POWER SUPPLIES (LINEAR & SWITCHING) FOR S-100, DISK DRIVES

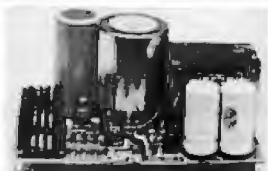
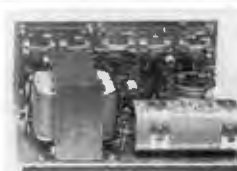
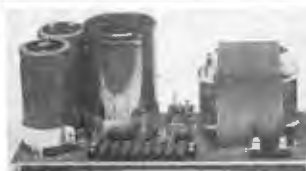

KIT 1, 2 & 3 For S-100

R3 For 3x8" (or 5 1/4") Disks

\$3 For S-100 & Two Disks

### S-100 & DISK POWER SUPPLY "S3" OPEN FRAME, ASSY. & TESTED, 6 OUTPUTS. SIZE: 10" (W) x 6" (D) x 5" (H) 102.95

REGUL. OUTPUTS FOR DISKS: +5V @ 5A OVP, -5V @ 1A, +24V (OR +12V) @ 5A-7A PEAK. ADJUSTABLE AND UNREGUL. OUTPUTS FOR S-100: +8V @ 14A, ±16V @ 3A. FUSES PROTECT ALL REGUL. OUTPUTS. IDEAL FOR THE MAINFRAME WITH 12 SLOTS & 2 x 8" or 5 1/4" FLOPPY (OR 1x FLOPPY & 1x HARD DISK).

### DISK POWER SUPPLIES: OPEN FRAME, ASSY. & TESTED, REGULATED, ADJUSTABLE & FUSES PROTECT.

ITEM	IDEAL FOR	+5V OVP	-5V (or -12V)	+24V (or +12V)	+8V Unreg.	SIZE W x D x H	PRICE
R0	2 x 8" SLIMLINE	2.5A		2.5A - 5A Peak		5" x 4" x 4"	49.95
R1	2 x 8" or 2 x 5 1/4" DISK	3A	1A	3A - 5A Peak	2A	8" x 4" x 3 3/4"	54.95
R2	3 x 8" (or 5 1/4") FLOPPY	6A	1A (or 2.5A)	6A - 8A Peak		1. 8 1/2" x 5" x 4 3/4" or 2. 10" x 4 3/4" x 3 3/4"	69.95
R3	or 1x Floppy & 1x Hard	6A	1A	6A - 8A Peak		1. 9" x 6 1/4" x 4 3/4" or 2. 9" x 5 1/4" x 5 1/4"	69.95

OPTION: ±12V @ 1A CAN BE ADDED TO ITEM "R3" SIZE 1. ONLY, COSTS \$12.00 MORE.

### S-100 POWER SUPPLY KITS (OPEN FRAME WITH BASE PLATE, 3 HRS. ASSY. TIME)

ITEM	(IDEAL FOR)	+8V	-8V	+16V	-16V	+28V	SIZE: WxDxH	PRICE
KIT 1	15 CARDS	15A	---	2.5A	2.5A	---	12" x 5" x 4 3/4"	54.95
KIT 2	20 CARDS	25A	---	3A	3A	---	12" x 5" x 4 3/4"	61.95
KIT 3	DISK SYSTEM	15A	1A	3A	3A	5A	13 1/2" x 5" x 4 3/4"	69.95

### POWER TRANSFORMERS (WITH MOUNTING BRACKETS)

ITEM	PRIMARY	SECONDARY #1	SECONDARY #2	SECONDARY #3	SIZE WxDxH	PRICE
T1	110/120	2x8 Vac, 15A	28 Vac, CT, 2.5A	---	3 3/4" x 3 3/4" x 3 3/4"	22.95
T2	110/120	2 x 8 Vac, 25A	28 Vac, CT, 3.5A	---	3 3/4" x 4 3/4" x 3 3/4"	28.95
T3	110/120	2 x 8 Vac, 15A	28 Vac, CT, 3A	48 Vac, CT, 2.5A	3 3/4" x 4 3/4" x 3 3/4"	30.95
T4	110/120	2 x 8 Vac, 6A	28 Vac, CT, 1.5A	48 Vac, CT, 3A	3 3/4" x 3 3/4" x 3 3/4"	23.95
T5	110/120	16 Vac, CT, 3A	28 Vac, CT, 2A	(48 Vac, if specified)	3" x 3" x 2 1/2"	15.95

**SHIPPING FOR EA. PWR SUPPLY:**  
\$5.50 IN CALIF.; \$8.00 IN OTHER STATES;  
\$18.00 IN CANADA. FOR EA. TRANSFORMER: \$5.00 IN ALL STATES; \$12.00 IN CANADA. CALIF. RESIDENTS ADD 6% SALES TAX.

#### ATTENTION O.E.M.'S

**YOUR SPECIAL NEEDS OR DESIGNS OF TRANSFORMER, LINEAR & SWITCHING PWR SUPPLY WILL BE MADE TO ORDER AT SUNNY LOW LOW COST & FASTEST DELIVERY.**

#### MAILING ADDRESS:

P.O. BOX 4296  
TORRANCE, CA 90510  
TELEX 182558

#### SUNNY INTERNATIONAL

(TRANSFORMERS MANUFACTURER)  
(213) 328-2425 MON-SAT 9-6

#### SHIPPING ADDRESS:

22129 1/2 S. VERMONT AVE  
TORRANCE, CA 90502



# ADVANCED COMPUTER PRODUCTS

SEND \$2.00 FOR 104 PAGE CATALOG

## 16K Apple™ Ramcard

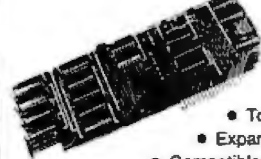

LIST 195  
ACP  
\$69.95

- Full 1 year warranty
- Top quality — gold fingers
- Expand Apple II 48K to 64K
- Compatible with Z-80 Softcard™
- Allows system to run with CP/M™, PASCAL, DOS3.3, COBAL, Visicalc, etc.
- Supplied with extra 16K RAM & has (2) LED's

## 32K STATIC RAM

- 2 or 4 MHz  
Expandable  
Uses  
2114's
- 16K 4 MHz Kit \$159.95
  - 16K 4 MHz A&T \$177.95
  - 32K 4 MHz Kit \$199.95
  - 32K 4 MHz A&T \$239.00
  - BAFIE BOARD \$89.95
  - Bare Bdw/all parts less mem \$90.95

## BARE BOARDS

- S-100 Sound Board \$34.95
- 8080A CPU \$34.95
- 32K Static RAM (2114) \$34.95
- 8K EPROM (2708) \$24.95
- 2708/2716 EPROM \$34.95
- ACP Proto Board \$22.95
- Vector 8800 Proto \$22.00
- Vector 8800 11 slot MB \$29.95
- ACP Extender with connector \$18.95
- 13 Slot Mother Board (WMC) \$32.95
- 8 Slot Mother Board (FMC) \$29.95
- 8 Slot Mother Bd (Expanded) \$34.95
- Floppy PCB (8" SUGART) \$39.95
- 1000 (A5-B910) Sound Board \$34.95
- Apple Sound Board \$24.95

## 64K CMOS RAM

S100 (200nS)  
Uses 2716's \$349.00  
or 6116's  
Assembled & Tested \$399.00

## MOSTEK 4K RAMS

29¢ ea.  
200,000 pieces in stock — priced to move.  
Same as 8K/40K except 1 mV refresh  
MK4015 4Kx1 RAM

## PMI "Super Beta" LOW POWER AMPLIFIER

INTERNALLY COMPENSATED  
P/N OP12GJ  
Voltage = 1.0 mV  
Ibias = 5.0mA  
Gain = 40V/mV  
(quantity limited)

## 4K STATIC RAM

SELL-OFF  
10/\$9.90  
Same as TMS4044  
but designed specifically  
for Z-80 based systems. This  
is a full-spec 4Kx1 RAM, 450nS.  
Order P/N Zilog 6104-4 while supply lasts.

## Zilog Z8 CPU

with TINY BASIC  
Debug prog. \$49.95  
Plus 6132 companion  
quasi-static RAM 29.95

## Stepper Motor

NEW  
USED IN DATA PRODUCTS PRINTER  
\$19.95 ea.

## CONNECTORS

- DB25P (RS232) \$3.25
- DB25S Female 3.75
- Hood 1.25
- 5ft with Hood, Sale 7.50
- 22/44 S/T, NM 2.50
- 43/88 S/T, MDT 6.50
- 50/100 S-100 Connector W/W 4.95
- 50/100 S-100 Connector S/T 3.95

## 16K Memory Expansion Kits for Apple/TRS-80

8 pos 4116 16K  
200/250's  
Specify computer  
CALL FOR VOLUME PRICING

## "D" SUB CONNECTORS

Unreal prices. DB37 male, DB25 female, Gold PC mount with mounting holes. Mfg. AMP. Specify 25 or 37 pins.  
BD37 \$2.50 DB25 \$1.95

## Astec RF Modulator

for COLOR & B/W  
P/N 1082 Channel 2 or 4 \$8.95

## 1200 BAUD MODEM IC

Features:  
• 1200 Baud  
• 40 Pin  
• 5Volts Only  
\$1.90

## PARALLEL ALPHA NUMERIC PRINTER

19 Column Printer prints 16 numerical columns plus 3 columns which have math, alpha and other notations. Each wheel has 12 positions with position 12 blank. wide adding machine tape and a dual color ink ribbon. Input data parallel with four bit BCD comparator circuit (schematic provided). Print rate, 3 lines per second. Operating voltage 22-28VDC with typical cycle time of 340ms. Size 6 1/2" W x 3 1/2" H x 5 1/2" Dp. Now \$175.00 ea. 3/\$45

## MICROPROCESSORS

Z8001	990.00	6205-1	\$14.95	6803P	14.95
Z8002	99.00	Z8011	8.00	8003	14.95
Z80	8.95	Z8014	14.95	8008	12.80
Z80A	11.95	8000A	49.95	8073A	34.95
Z8002Z	18.95	8001	8.00	F75	48.95
8080	9.95	8082A	18.99	8748	39.90
1802	8.75	84010	29.95	8900	30.00
8080A	4.75	8600	11.75	6598	48.00
Z808	14.95	8958B	19.95	68020	29.95

## SUPPORT

6116/2016	87.95	2147	85.99	5290	81.99
8264-64K	8.50	411	5.99	5208	1.49
4118-2	1.99	414	4.99	6508	4.49
4118-2	812.95	1101	89	6519	6.79
2101	3.93	103	99	6861	3.70
2102	7.9	4027	4.99	6804	3.99
21L02-2	1.49	4044	3.99	6805	7.99
21L02-4	1.29	4050	4.99	9130	8.99
2111	3.49	4080	4.99	9140	8.99
2112	3.3	4086	3.99	93415	6.99
2114	1.99	4115	4.99	93425	6.99
2114L-2	3.25	4200	7.95		
2114L-4	2.29	4402	1.99		
2125	6.99	5280	4.80		

## MOS PROMS

2784 (8Kx8) TS	399.95	2708 (160x8) TS	95.75
2732 (4Kx8) TS	12.95	2708 (160x8) TS	95.75
2716 (2Kx16) TS	6.75	7024	6.75
(2Kx16) TS	7.95	MMS2040	14.50
TMS2718, EV, 12V	17.95	MMS2040	14.50
2758, 5V, (450nm)	3.50		

## HI-TECH

213-901 (5V) Driver	99.50	DA308	99.95
3513-005 (5V) Linear	18.95	DA310	9.95
3513-AD01 (5V) Linear	14.95	8038 Function Generator	4.95
MC4867 (8 A/D) Digital	12.95	MC424 VCO	2.95
MC4867 (8 A/D) Digital	12.95	LM958 VCO	1.95
MC4867 (8 A/D) Digital	12.95	MC4208 Function Generator	3.75
1771-01 (4.5V) Multiplexer	11.95	MC4208 (4.5V) 12M	3.95
1781 Dual Flip-Flop	29.95	AY101 (2V, 12V)	4.95
1791-01 Dual Flip-Flop	36.95	AY101 (4V, 12V, 16V)	9.95
1791-02 Dual Flip-Flop	44.95	AY101 (4V, 12V, 16V)	9.95
1793 00.05 Flip-Flop	44.95	8940Z	7.95
1797 00.05 Flip-Flop	54.95	8940Z	7.95
1891 Data Separator	18.95	2388 010	8.95
2143 Clock Generator	18.95	18718 Audio	24.95
6706 0.06 Inverter	13.95	MC1411	11.95
6701 1.06 Binary	22.00	4102	14.95
8703 1.06 Tr	13.50	801941	9.95
9809 Volt to Frequency Conv	7.25	C040110	16.95
8750 3rd Order BCD	33.25	849250	15.95
14066 6 bit	3.95	4V5-2316	11.95
14538 8 bit	4.50	4V5-2000	13.75
DA01 0.1 A	1.50	M9373AACC	8.95

## SOCKETS

LOW PROFILE SOCKETS (TIN)

1-24	25-49	50-100
6 pin LP	18 15 14	
14 pin LP	20 19 18	
18 pin LP	22 21 20	
20 pin LP	23 22 21	
20 pin LP	34 32 30	
22 pin LP	20 27 24	
24 pin LP	38 37 36	
26 pin LP	40 44 43	
40 pin LP	65 58 56	

## 3L WIREWRAP SOCKETS (GOLD)

1-24	25-49	50-100
8 pin WW	95 54 49	
10 pin WW (Tin)	65 63 58	
14 pin WW	75 73 67	
16 pin WW	80 77 70	
18 pin WW	95 90 81	
20 pin WW	11 106 99	
22 pin WW	145 138 123	
24 pin WW	135 126 114	
26 pin WW	150 153 138	
40 pin WW	220 209 189	

## SUPER IC CLOSEOUT SPECIALS

LLK0003	2/81.98	298121	3/81.00	8206A CPU	2.95	5027 CRT	99.95
74LS268	3/1.99	516 2862	3.95	2102 RAM	75	11C24	6.95
74LS377	2/1.99	742897	1.98	4050 RAM	1.49	9540K	2.99
74LS241	2/1.99	2788 EPROM	2.95	80300 CPU	14.95	MMS320	2.99
8256	8.95	74173/BT10	5/1.99	745387	1.98	9131 RAM	1.99
8561 RAM	2.95	280A CPU	4.95	3708 EPROM	8/29.95	EMM402	1.98
LM7333CN	3/1.99	8522	9.99	74LS333	3/1.00	11C33	3/2.50
MC1414	3/1.99	8502 CPU	5.95	2114	8/14.50	8700 A/D	27/39.95

\* CP/M trademark of Digital Research. Apple trademark of Apple Computer.

TOLL FREE  
**800-854-8230**  
TXN  
**910-595-1565**

## LINEAR

78H05K	55.95	LM1414N	\$1.90
78M05	1.49	LM1458CN/N	.98
78M12	1.49	MC1468N	.80
LM1084H	3.95	MC1469N	.80
LM300H	.99	LM1438N	.80
LM301CN	.35	LM1439N	1.99
LM304A	1.98	LM1459N	.95
LM304H	1.98	LM1459N	.95
LM309H	3.25	LM1459N	3.10
LM307CN	.29	LM2111N	1.75
LM309CN	.98	LM2900N	.99
LM309N	1.49	LM2901N	1.99
LM310CN	1.25	LM2917N	2.95
LM310CN	1.25	LM2917N	2.95
LM311D/CN	.89	CA3013T	2.19
LM312H	1.75	CA3018T	1.99
LM317T	1.70	CA3021T	3.46
LM318CN	1.49	CA3021T	2.99
LM319N	1.25	CA3021T	2.75
LM3200-XX*	.30	CA3039T	1.29
LM320T-XX*	.30	CA3049A	1.29
LM320A-XX*	1.25	LM3059N	1.49
LM323X	4.95	CA3059N	3.19
LM324N	.95	CA3060N	3.19
LM337K	5.95	CA3062N	4.95
LM339	8.95	LM339N	8.95
LM339N	.95	CA3062T	1.29
LM340K-XX*	1.75	CA3061N	1.69
LM340T-XX*	1.25	CA3062N	1.69
LM340N-XX*	1.26	CA3061N	1.56
LM349N	1.65	CA3069N	1.65
LM349A	1.20	CA3069N	2.98
LM350K	5.80	CA3069N	3.49
LM358CN	.98	CA3097N	1.99
LM380N	1.40	CA3130T	1.30
LM372N	1.95	CA3140T	1.19
LM378N	3.75	CA3140T	2.48
LM379N	2.75	CA3140T	1.39
LM380CN/N	1.25	CA3100N	.95
LM381N	1.79	CA3100N	1.50
LM383T	1.95	MC3423N	1.40
LM389N	1.25	MC3460N	3.95
LM389N	1.40	SG5324N	3.95
LM390N	1.95	CA3097N	3.75
NE511V/T	3.75	LM3900N	.50
NE555V	.39	LM3905N	1.18
NE555N	.98	LM3909N	.98
NE558T	19.95	LM3914N	3.76
NE568A/N	1.26	LM3919N	3.95
NE568N	1.75	LM3919N	3.75
NE567V/H	.50	RC4138N	1.95
NE592N	2.75	RC4138N	1.10
LM702H	1.89	RC4151N	3.70
LM709N/H	.29	RC41941H	4.95
LM710N/H	.79	RC41951H	5.40
LM711N/H	1.29	LM7301N	1.25
LM719N	1.95	LM7301N	1.50
LM723N/H	.65	SN75451N	.55
LM730V/H	.98	SN75451N	.55
LM739N	1.15	SN75451N	.49
LM741CN/H	.33	SN75451N	.49
LM741CN/H	.19	SN75451N	.49
LM747V/H	.79	SN75491N	.89
LM748N/H	.39	SN75491N	.89
LM7800CN	2.95	SN75491N	.89
LM1310N	1.90	SN75491N	.89
MC1330	1.95	LM749CN	4.20
MC1360	1.95	LM749CN	1.95
MC1365	1.75		

## 74S00

74S00 \$ .30	74S124	3.89	74S244	\$2.99	
74S02	43	74S133	5.4	74S251	1.25
74S03	45	74S134	6.9	74S252	1.39
74S04	52	74S135	1.15	74S257	1.89
74S05	52	74S136	1.88	74S258	1.29
74S06	49	74S138	1.29	74S260	7.75
74S09	49	74S139	1.20	74S262	2.79
74S10	42	74S140	1.73	74S269	2.79
74S11	42	74S141	2.20	74S289	2.55
74S12	42	74S142	1.20	74S373	3.10
74S22	42	74S150	1.29	74S374	3.10
74S20	42	74S158	2.79	74S471	7.85
74S32	40	74S174	1.48	74S472	7.85
74S38	119	74S175	1.49	74S473	7.85
74S12	72	74S182	2.99	74S474	3.30
74S51	42	74S194	1.89	74S475	9.95
74S54	46	74S195	1.89	74S570	5.75
74S56	46	74S196	1.89	74S571	5.75
74S57	46	74S240	2.75	74S572	6.95
74S92	72	74S241	2.75	74S573	8.95
74S113	72	74S242	2.99	74S594	2.90
74S114	72	74S243	2.99	74S594	2.90</



# ADVANCED COMPUTER PRODUCTS

SEND \$2.00 for 104 PAGE CATALOG

## TRIMLINE DIMENSION SYSTEMS

**Apple II Compatible Disk Drive**

Totally compatible to Apple Drives.

only **\$329.00**

Controller ..... \$99.00

Just plug in and run.

## Vista Computer Company

**Add 8" Disk Drives To Your Apple II Up To 2.4 Megabyte!**

Now "TRIMLINE V1100" with Tandon Thinline DS DD Drives.

Tandon Dual DS DD ..... \$1985.00  
 Qume Dual DS DD ..... \$1895.00  
 Sharp Dual 801R ..... \$1485.00

## Apple Computer Authorized Dealer

### ON DISK FOR APPLE SAVE UP TO 40% OFF

Model	Price	Model	Price
Vicacalc 3.3	\$189	Vicacalc 3.3	\$189
Vicacalc 3.3 Supercalc	189	Vicacalc 3.3 Supercalc	189
Vicacalc 3.3 Supercalc II	235	Vicacalc 3.3 Supercalc II	235
Vicacalc 3.3 Supercalc III	198	Vicacalc 3.3 Supercalc III	198
Vicacalc 3.3 Supercalc IV	159	Vicacalc 3.3 Supercalc IV	159
Vicacalc 3.3 Supercalc V	199	Vicacalc 3.3 Supercalc V	199
Vicacalc 3.3 Supercalc VI	239	Vicacalc 3.3 Supercalc VI	239
Vicacalc 3.3 Supercalc VII	89	Vicacalc 3.3 Supercalc VII	89
Vicacalc 3.3 Supercalc VIII	34	Vicacalc 3.3 Supercalc VIII	34
Vicacalc 3.3 Supercalc IX	287	Vicacalc 3.3 Supercalc IX	287
Vicacalc 3.3 Supercalc X	488	Vicacalc 3.3 Supercalc X	488
Vicacalc 3.3 Supercalc XI	235	Vicacalc 3.3 Supercalc XI	235
Vicacalc 3.3 Supercalc XII	82	Vicacalc 3.3 Supercalc XII	82
Vicacalc 3.3 Supercalc XIII	159	Vicacalc 3.3 Supercalc XIII	159
Vicacalc 3.3 Supercalc XIV	189	Vicacalc 3.3 Supercalc XIV	189
Vicacalc 3.3 Supercalc XV	189	Vicacalc 3.3 Supercalc XV	189
Vicacalc 3.3 Supercalc XVI	132	Vicacalc 3.3 Supercalc XVI	132
Vicacalc 3.3 Supercalc XVII	219	Vicacalc 3.3 Supercalc XVII	219
Vicacalc 3.3 Supercalc XVIII	178	Vicacalc 3.3 Supercalc XVIII	178
Vicacalc 3.3 Supercalc XIX	72	Vicacalc 3.3 Supercalc XIX	72
Vicacalc 3.3 Supercalc XX	69	Vicacalc 3.3 Supercalc XX	69
Vicacalc 3.3 Supercalc XXI	74	Vicacalc 3.3 Supercalc XXI	74
Vicacalc 3.3 Supercalc XXII	1185	Vicacalc 3.3 Supercalc XXII	1185
Vicacalc 3.3 Supercalc XXIII	229	Vicacalc 3.3 Supercalc XXIII	229
Vicacalc 3.3 Supercalc XXIV	229	Vicacalc 3.3 Supercalc XXIV	229

## HEWLETT PACKARD

**HP85A Computer** ..... \$1985  
**HP87 Computer** ..... 1945

- 82907A 32K Model ..... 239
- 82908A 64K Model ..... 349
- 82909A 128K Model ..... 599
- 82900A CP/M with 64K ..... 425

**HP12B Computer** ..... 1985  
**747D Low Cost Plotter** ..... 1265  
**9895A 8" Dual Floppy** ..... 5135

## HEWLETT PACKARD CALCULATORS

Model	Price
HP41C Prog Scientific	\$189
HP41CV w/2.2K Memory	258
HP41 Memory Module	83
HP41 Quad RAM	83
HP41 Card Reader	159
HP41 Printer	292
HP41 Optical Wand	99
HP41 Interface Loop	119
HP11C Advanced Scientific	119
HP12C Financial	129
HP34C Prog. Scientific	112
HP38C Prog. Business	118

## Apple Computer Authorized Dealer

Model	Price	Model	Price
Apple II Plus w/48K	\$1530.00	Apple II Plus w/48K	\$1530.00
Apple II Plus w/64K	1728.00	Apple II Plus w/64K	1728.00
Apple II System Special w/48K	2519.00	Apple II System Special w/48K	2519.00
Z80 Card, Vision 80	3495.00	Z80 Card, Vision 80	3495.00
Apple III w/128K	3495.00	Apple III w/128K	3495.00
Apple III w/256K	4495.00	Apple III w/256K	4495.00
ProFile Hard Disk Drive	3495.00	ProFile Hard Disk Drive	3495.00
Vista Apple II Timecard	195.00	Vista Apple II Timecard	195.00

## APPLE HARDWARE

Model	Price	Model	Price
Apple II Disk II w/Control	\$545.00	Apple II Disk II w/Control	\$545.00
Apple II Disk II w/o	525.00	Apple II Disk II w/o	525.00
Apple Family System	2495.00	Apple Family System	2495.00
Prototype Card	24.00	Prototype Card	24.00
IEEE-488 Interface	450.00	IEEE-488 Interface	450.00
Extended Warranty - 1 yr	225.00	Extended Warranty - 1 yr	225.00
Super Serial Card	185.00	Super Serial Card	185.00
Language Cards	185.00	Language Cards	185.00
Graphic Tablet w/IO	295.00	Graphic Tablet w/IO	295.00

## MORE HARDWARE

Model	Price	Model	Price
MICROSOFT Z80 Software	\$395.00	MICROSOFT Z80 Software	\$395.00
16K Ramcard	186.00	16K Ramcard	186.00
The Premium Package	899.00	The Premium Package	899.00
SSM AIG-4 Function Serial	225.00	SSM AIG-4 Function Serial	225.00
AIC Serial-Parallel	195.00	AIC Serial-Parallel	195.00
KEYBOARD COMPANY Numeric Keyboard	149.95	KEYBOARD COMPANY Numeric Keyboard	149.95
Apple II Joystick	49.95	Apple II Joystick	49.95
Apple II Handcontrollers	29.95	Apple II Handcontrollers	29.95
PROMETHEUS VERSAtrak Special Buffer	248.00	PROMETHEUS VERSAtrak Special Buffer	248.00
VERSAcard Four-in-One	199.00	VERSAcard Four-in-One	199.00
AUTO-DOC diagnostic	99.00	AUTO-DOC diagnostic	99.00
VISTA COMPUTER CO. Vision 80 8028 Card	385.00	VISTA COMPUTER CO. Vision 80 8028 Card	385.00
Vision 40 IQ-Card	199.00	Vision 40 IQ-Card	199.00
enhance	29.95	enhance	29.95
Vision 20 Lo case ROM	29.95	Vision 20 Lo case ROM	29.95
800 8" DS, DD	585.00	800 8" DS, DD	585.00
Controller	585.00	Controller	585.00
PRDM Development Bd	595.00	PRDM Development Bd	595.00
GB75 IBM typewriter IO	195.00	GB75 IBM typewriter IO	195.00
40 Char Type-head	49.95	40 Char Type-head	49.95
Buffer	35.00	Buffer	35.00
VIDEX Videoterm 80x24 Card	345.00	VIDEX Videoterm 80x24 Card	345.00
Keyboard Enhancer II	149.00	Keyboard Enhancer II	149.00
Soft Switch	35.00	Soft Switch	35.00
Function Grip Keys	79.00	Function Grip Keys	79.00
PRACTICAL PERIPHERALS 18K Microbuffer	259.00	PRACTICAL PERIPHERALS 18K Microbuffer	259.00
32K Microbuffer	299.00	32K Microbuffer	299.00
Snapshot Option	69.00	Snapshot Option	69.00
VOTRAX Type II Talk Speech	375.00	VOTRAX Type II Talk Speech	375.00
SCOTT INSTRUMENTS Voice Recogniz'n VET90	799.00	SCOTT INSTRUMENTS Voice Recogniz'n VET90	799.00
CORVUS 5 Mb Hard Disk	3750.00	CORVUS 5 Mb Hard Disk	3750.00
10 Mb Hard Disk	5380.00	10 Mb Hard Disk	5380.00
20 Mb Hard Disk	6450.00	20 Mb Hard Disk	6450.00
ORANGE MICRO The Grappler I/O	198.00	ORANGE MICRO The Grappler I/O	198.00
SATURN SYSTEMS 32K RAM Card	239.00	SATURN SYSTEMS 32K RAM Card	239.00
84K RAM Card	425.00	84K RAM Card	425.00
128K RAM Card	599.00	128K RAM Card	599.00
NOVATION Apple-Cat II	389.00	NOVATION Apple-Cat II	389.00
HAYES MICROCOMPUTER Hayes Chromograph	249.00	HAYES MICROCOMPUTER Hayes Chromograph	249.00
Micromodem II	349.00	Micromodem II	349.00
Smartmodem	299.00	Smartmodem	299.00
MOUNTAIN COMPUTER CPS Multifunction	238.00	MOUNTAIN COMPUTER CPS Multifunction	238.00
RAM Plus	189.00	RAM Plus	189.00
Expansion Chassis	750.00	Expansion Chassis	750.00
Misc System	339.00	Misc System	339.00
100,000 Day Clock	375.00	100,000 Day Clock	375.00
The Clock	280.00	The Clock	280.00
A/D plus D/A	350.00	A/D plus D/A	350.00
Supertalker	189.00	Supertalker	189.00
Introl X-10 Controller	200.00	Introl X-10 Controller	200.00
ROM Plus	129.00	ROM Plus	129.00
Keyboard Filter ROM	55.00	Keyboard Filter ROM	55.00
Copy ROM	55.00	Copy ROM	55.00
ROM Writer	175.00	ROM Writer	175.00
MAR ENTERPRISES Sup 16M 80x24 Card	388.00	MAR ENTERPRISES Sup 16M 80x24 Card	388.00
Sup 15Switch 8 Amp Power Supply	285.00	Sup 15Switch 8 Amp Power Supply	285.00
Sup/Mod II RF Modulator	35.00	Sup/Mod II RF Modulator	35.00
Apple Fan	55.00	Apple Fan	55.00
ALS The "Z" Card Z80 card	285.00	ALS The "Z" Card Z80 card	285.00
SmartTerm 80x24 Card	349.00	SmartTerm 80x24 Card	349.00
The Synergizer Package	699.00	The Synergizer Package	699.00

## 16K RAM CARD

## Apple II 16K Compatible with Z80 Software ... PASCAL CP/M

Full 1 year Warranty Top Quality by COEX

**NEW LOW PRICE \$69.95**

Also from COEX NEW EPSON Parallel Interface for Apple

With cable ..... \$54.95

TERMS: 10% Down, Balance Due Upon Receipt. Shipping and handling charges extra. Cash orders receive 2% discount. All prices include sales tax. Payment in full required for orders shipped outside the continental United States. Prices subject to change without notice. Some items may be discontinued without notice. Delivery times may vary.

**Vista COMPUTER**

**Vision 80** as reviewed in May BYTE pg. 266

This is the widely discussed Cadillac 80 column card for the Apple II. The Vision 80 responds to more Apple Text screen commands than any other board. It supports PASCAL, Microsofts Z80 Softcard and can be used as an intelligent terminal.

List Price.... \$395.00 **Special Low Price.... \$269.00**

The Vision 80 can also be used in conjunction with the Vision 40 (allows enhanced character sets) and the Vision 20 for lower case

**IBM COMPARE UNBEATABLE ADD-ON PRICES!**

- **MEMORY**  
**VISTA 576K Expandable In 64K Increments**  
 • w/256K populated ..... only \$999  
 • w/512K populated ..... only \$1599  
 • w/576K populated ..... only \$1799
- **VISTA/SUPERCALC/SUPERCACHE**  
 • 192K with IBM SUPERCALC ..... 799
- **MICROSOFT RAMCARD**  
 • 64K w/RAMDRIVE (expandable) ..... 419  
 • 256K w/RAMDRIVE ..... 899
- **AST MEMORY CARD**  
 • 64K EXPANDABLE ..... 489  
 • 256K w/PARITY ..... 899
- **AST "COMBO CARD"**  
 • MEMORY, ASYNCH COMM, PARALLEL  
 • 64K SP ..... 525  
 • 256K SP ..... 1049
- **INTERFACE CARDS**  
**AST ADVANCED COMMUNICATIONS**  
 • 2 RS232 PORTS ..... 269  
 • BABY BLUE Z80 CARD ..... 550
- **PROTOTYPE CARD** ..... 69
- **EXTENDER CARD** ..... 29
- **DISK DRIVES - ADD-IN (Compatible)** ..... 239
- **EPSON ADD-ON PRINTER** ..... 429
- **SUPR'MOD V RF MODULATOR** ..... 49
- **TEXT TO IBM CABLE** ..... 49

**OTRONA ATTACHE**

• Truly Portable 18 lbs.  
 • Includes CP/M<sup>®</sup>, Wordstar-plus<sup>™</sup>, Basic 80, Visi<sup>®</sup> & Chartpak.  
 • Includes (2) Double Density, Double Sided thin drives. • 360K Bytes each drive.

**ACP PRICE ..... \$3595.00**

**KAYCOMP II**

• Full 9" Green Screen  
 • CP/M Based  
 • Portable Business Computer

• Complete w/CP/M 2.2 M BASIC, Magic Worksheet, Select Word Processing and Teach

**ACP Price ..... only \$1775**

**ATARI**

MODEL LIST ACP

800 with 18K	\$1060.00	\$689.99
800 with 48K	1280.00	789.95
800 with 32K + 128K		1295.00
810 Disk Drive	600.00	489.85
825 Printer	999.00	899.85
830 Acoustic Modem	199.00	159.95
850 Interface Modules	219.95	189.95
Alan Viscasic	200.00	189.00
Alan PAC-MAN		CALL
Microtek 16K RAM	99.00	75.00
Microtek 32K RAM	199.00	149.00
Axalon 128K RAM		CALL
400 with 18K	399.95	329.95

**5 1/4" DISK DRIVES**

Model	Price	Model	Price
TM100-1 SDD	\$219.95	TM100-1 SDD	\$219.95
SA400 SDD	249.95	SA400 SDD	249.95
TM100-2 DSD	298.95	TM100-2 DSD	298.95
TM100-3 SDD	298.95	TM100-3 SDD	298.95
TM100-4 SDD	419.95	TM100-4 SDD	419.95
B-51 SDD	224.95	B-51 SDD	224.95
B-52 DSD	334.95	B-52 DSD	334.95
B-91 SDD	359.95	B-91 SDD	359.95
B-92 DSD	459.95	B-92 DSD	459.95

**5 1/4" Cabinets with Power Supply**

Single cabinet w/power supply ..... \$69.95  
 Dual cabinet w/power supply ..... \$49.95

**8" DISK DRIVES**

Model	Price	Model	Price
SAS01R SDD	\$395.00	SAS01R SDD	\$395.00
SAS1R OSD	549.00	SAS1R OSD	549.00
TR184B-1 SDD	425.00	TR184B-1 SDD	425.00
TR184B-2 OSD	575.00	TR184B-2 OSD	575.00
DT-8 OSD	525.00	DT-8 OSD	525.00
FDD100-B SDD	299.00	FDD100-B SDD	299.00
FDD200-B OSD	399.00	FDD200-B OSD	399.00
V1000 Case/Power Supply	375.00	V1000 Case/Power Supply	375.00
Dual 8" Power Supply	399.00	Dual 8" Power Supply	399.00

## APPLE System Saver FAN

Surge Suppressor Fan. Double Outlet Receptacle ..... **\$79.95**

**SANYO**

FCC CLASS 2 APPROVED

Model	List Price	ACP Price
4509 8" BW	\$210.00	\$168.00
5109CA 8" Green	220.00	178.00
8012C 12" BW	250.00	210.00
8012CA 12" Green	260.00	220.00
8013 13" Color	470.00	422.00
5113 13" RGB	895.00	895.00

NEW Down & Dirty  
 2012 12" BW ..... 145.00  
 2112 12" Green ..... 165.00

## USI Computer Products

**SANYO EQUIVALENT**

Model	List Price	ACP Price
PI 8" Green	\$199.00	\$159.00
PI 8 1/2" Green	199.00	149.00
PI 11 1/2" Orange	249.00	199.00

## TERMINALS

**TELEVIDEO**

Model	Price	Model	Price
810C	\$599	810C	\$599
920C	789	920C	789
825C	789	825C	789
950	950	950	950

**SOROC**

Model	Price	Model	Price
IO 120	\$695	IO 120	\$695
IO 130	999	IO 130	999
IO 140	999	IO 140	999

**TOLL FREE 800-854-8230**

1-800-854-8230

1-910-595-1565

**C. Itoh**

MX90 ..... \$429.00  
 MX90T ..... 529.00  
 MX100T .....

# DIGITAL RESEARCH COMPUTERS

(214) 271-3538

## 32K S-100 EPROM CARD

**NEW!**

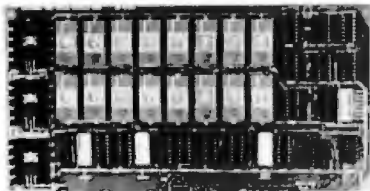

**\$79.95**  
KIT

USES 2716's  
Blank PC Board - \$34  
ASSEMBLED & TESTED  
ADD \$30

SPECIAL: 2716 EPROM's (450 NS) Are \$9.95 Ea. With Above Kit.

### KIT FEATURES

- 1 Uses +5V only 2716 (2Kx8) EPROM's
- 2 Allows up to 32K of software on line!
- 3 IEEE S-100 Compatible
- 4 Addressable as two independent 16K blocks
- 5 Cromemco extended or Northstar bank select
- 6 On board wait state circuitry if needed
- 7 Any or all EPROM locations can be disabled
- 8 Double sided PC board, solder-masked, silk-screened.
- 9 Gold plated contact fingers
- 10 Unselected EPROM's automatically powered down for low power
- 11 Fully buffered and bypassed
- 12 Easy and quick to assemble.

## 64K S100 STATIC RAM

**\$349<sup>00</sup>**  
KIT

**NEW!**

LOW POWER!  
RAM OR EPROM!  
BLANK PC BOARD  
WITH DOCUMENTATION  
\$55

SUPPORT ICs + CAPS  
\$17.50

FULL SOCKET SET  
\$14.50

FULLY SUPPORTS THE  
NEW IEEE 896 S100  
STANDARD  
(AS PROPOSED)

FOR 56K KIT \$299  
ASSEMBLED AND  
TESTED ADD \$40



### FEATURES:

- \* Uses new 2K x 8 (TMM 2016 or HM 6116) RAMs.
- \* Fully supports IEEE 896 24 BIT Extended Addressing.
- \* 64K draws only approximately 500 MA.
- \* 200 NS RAMs are standard. (TOSHIBA makes TMM 2016s as fast as 100 NS. FOR YOUR HIGH SPEED APPLICATIONS.)
- \* SUPPORTS PHANTOM (BOTH LOWER 32K AND ENTIRE BOARD).
- \* 2716 EPROMs may be installed in any of top 48K.
- \* Any of the top 8K (E000 H AND ABOVE) may be disabled to provide windows to eliminate any possible conflicts with your system monitor, disk controller, etc.
- \* Perfect for small systems since BOTH RAM and EPROM may co-exist on the same board.
- \* BOARD may be partially populated as 56K.

## 16K STATIC RAM KIT-S 100 BUSS

PRICE CUT!

**\$149<sup>95</sup>**  
KIT

FOR 4MHZ  
ADD \$10

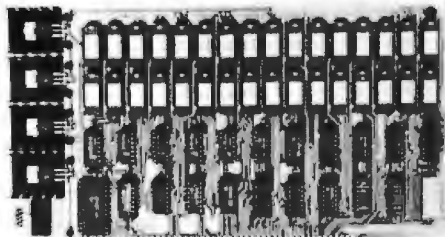

### KIT FEATURES

- 1 Addressable as four separate 4K Blocks.
- 2 ON BOARD BANK SELECT circuitry (Cromemco Standard!) Allows up to 512K on line!
- 3 Uses 2114 (450NS) 4K Static Rams
- 4 ON BOARD SELECTABLE WAIT STATES
5. Double sided PC Board with solder mask and silk screened layout Gold plated contact fingers
- 6 All address and data lines fully buffered
- 7 Kit includes ALL parts and sockets
- 8 PHANTOM is jumpered to PIN 67
- 9 LOW POWER under 1.5 amps TYPICAL from the +8 Volt Buss
- 10 Blank PC Board can be populated as any multiple of 4K

BLANK PC BOARD W/DATA-\$33  
LOW PROFILE SOCKET SET-\$12  
SUPPORT IC'S & CAPS-\$19.95  
ASSEMBLED & TESTED-ADD \$35

**OUR #1 SELLING  
RAM BOARD!**

## 64K SS-50 STATIC RAM

**\$259<sup>00</sup>**  
(48K KIT)

**NEW!**

LOW POWER!  
RAM OR EPROM!  
BLANK PC BOARD  
WITH  
DOCUMENTATION  
\$52

SUPPORT ICs + CAPS  
\$18.00

FULL SOCKET SET  
\$15.00

56K Kit \$309

64K Kit \$359

ASSEMBLED AND  
TESTED ADD \$40



### FEATURES:

- \* Uses new 2K x 8 (TMM 2016 or HM 6116) RAMs.
- \* Fully supports Extended Addressing.
- \* 64K draws only approximately 500 MA.
- \* 200 NS RAMs are standard. (TOSHIBA makes TMM 2016s as fast as 100 NS. FOR YOUR HIGH SPEED APPLICATIONS.)
- \* Board is configured as 3-16K blocks and 8-2K blocks (within any 64K block) for maximum flexibility.
- \* 2716 EPROMs may be installed anywhere on Board.
- \* Top 16K may be disabled in 2K blocks to avoid any I/O conflicts.
- \* One Board supports both RAM and EPROM.
- \* RAM supports 2MHZ operation at no extra charge!
- \* Board may be partially populated in 16K increments.

## STEREO! S-100 SOUND COMPUTER BOARD

**NEW!**

At last, an S-100 Board that unleashes the full power of two unbelievable General Instruments AY3-8910 NMOS computer sound IC's. Allows you under total computer control to generate an infinite number of special sound effects for games or any other program. Sounds can be called in BASIC, ASSEMBLY LANGUAGE, etc.

### KIT FEATURES:

- \* TWO GI SOUND COMPUTER IC'S.
- \* FOUR PARALLEL I/O PORTS ON BOARD
- \* USES ON BOARD AUDIO AMPS OR YOUR STEREO
- \* ON BOARD PROTO TYPING AREA
- \* ALL SOCKETS, PARTS AND HARDWARE ARE INCLUDED.
- \* PC BOARD IS SOLDERMASKED, SILK SCREENED, WITH GOLD CONTACTS.
- \* EASY, QUICK, AND FUN TO BUILD, WITH FULL INSTRUCTIONS.
- \* USES PROGRAMMED I/O FOR MAXIMUM SYSTEM FLEXIBILITY

Both Basic and Assembly Language Programming examples are included

### SOFTWARE:

SCL™ is now available! Our Sound Command Language makes writing Sound Effects programs a SNAP! SCL™ also includes routines for Register-Examine-Modify, Memory-Examine-Modify, and Play-Memory. SCL™ is available on CP/M™ compatible diskette or 2708 or 2716. Diskette-\$24.95 2708 - \$19.95 2716 - \$29.95. Diskette includes the source. EPROM'S are ORG at E000H (Diskette is 8 Inch Soft Sealed)

COMPLETE KIT!

**\$84<sup>95</sup>**

(WITH DATA MANUAL)

BLANK PC  
BOARD W/DATA  
\$31

## SPECIAL PURCHASE!

## UART SALE!

TR1602B - SAME AS TMS6011,  
AY5-1013, ETC. 40 PIN DIP

**TR1602B**

**\$2<sup>95</sup>**  
EACH

**4 For \$10<sup>00</sup>**

### CRT CONTROLLER CHIP

SMC #CRT 5037. PROGRAMMABLE FOR 80 x 24, ETC. VERY RARE  
SURPLUS FIND WITH PIN OUT. \$12.95 EACH.

### NEW! G.I. COMPUTER SOUND CHIP

AY3-8910. As featured in July, 1979 BYTE! A fantastically powerful Sound & Music Generator. Perfect for use with any 8 Bit Microprocessor. Contains: 3 Tone Channels, Noise Generator, 3 Channels of Amplitude Control, 16 bit Envelope Period Control, 2-8 Bit Parallel I/O, 3 D to A Converters, plus much more! All in one 40 Pin DIP. Super easy interface to the S-100 or other busses. **\$11.95** PRICE CUT!

SPECIAL OFFER: **\$14.95** each Add \$3 for 80 page Data Manual.

National Semiconductor 5257. Arranged 4K x 1. +5V, 18 PIN DIP. A Lower Power, Low Cost Replacement for TMS 4044. 450 NS. Several Boards on the way with 2716 EPROM's and 2716 RAMs. SUPER SURPLUS PURCHASE! PRIME NEW PARTS!

8 FOR \$16 32 FOR \$59.95

**Digital Research Computers**  
(OF TEXAS)

P.O. BOX 401565 • GARLAND, TEXAS 75040 • (214) 271-3538

TERMS: Add \$2.00 postage. We pay balance. Orders under \$15 add 75¢ handling. No C.O.D. We accept Visa and MasterCard. Tex. Res. add 5% Tax. Foreign orders (except Canada) add 20% P & H. Orders over \$50, add 85¢ for insurance.

ALL SALES ARE MADE SUBJECT TO THE TERMS OF OUR 90 DAY LIMITED WARRANTY. A COPY OF THIS WARRANTY IS AVAILABLE FREE, ON REQUEST.

**NEW  
LOWER PRICES**

**"THE BIG BOARD"  
OEM - INDUSTRIAL - BUSINESS - SCIENTIFIC  
SINGLE BOARD COMPUTER KIT!  
Z-80 CPU! 64K RAM!**

**NEW!**

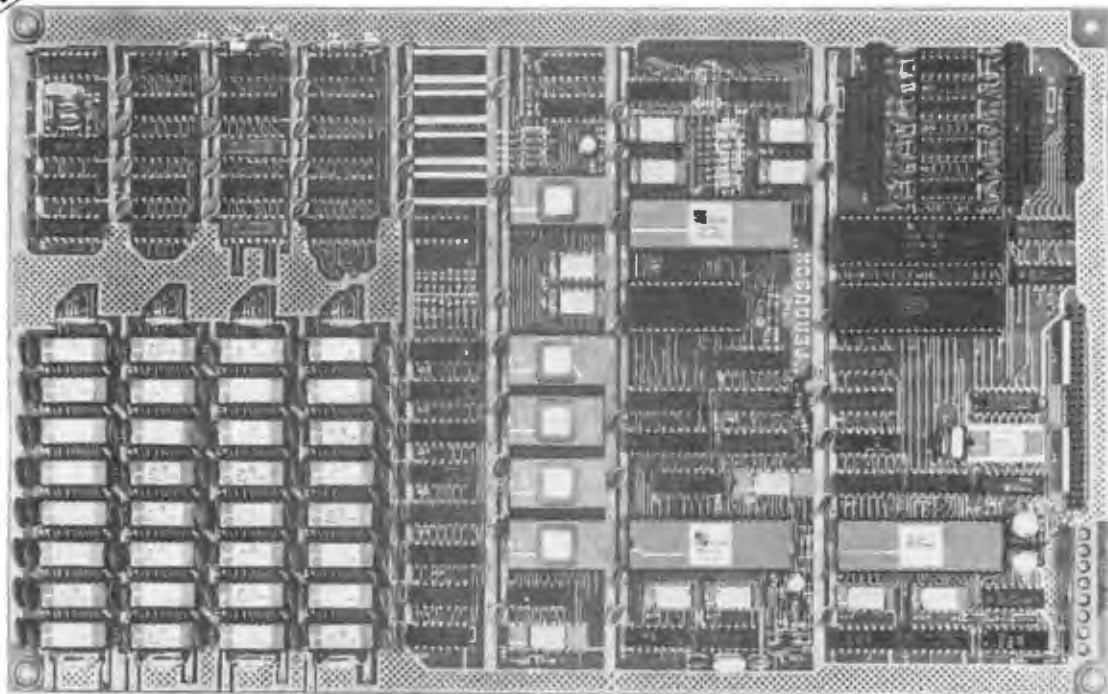

**PARTIALLY ASSEMBLED KITS**  
For All Sockets Installed  
And Soldered Add \$50.

**WANT MORE INFO?**  
Full Documentation and  
Schematics — \$5.

**THE BIG BOARD PROJECT:** Three years in the works, and maybe too good to be true. A tribute to hard headed, no compromise, high performance, American engineering! The Big Board gives you all the most needed computing features on one board at a very reasonable cost. The Big Board was designed from scratch to run the latest version of CP/M\*. Just imagine all the off-the-shelf software that can be run on the Big Board without any modifications needed! Take a Big Board, add a couple of 8 inch disc drives, power supply, an enclosure, C.R.T., and you have a total Business System for about 1/3 the cost you might expect to pay.

**\$399<sup>00</sup>\*\*** (64K KIT BASIC I/O)

SIZE: 8 1/2 x 13 1/2 IN.  
SAME AS AN 8 IN. DRIVE.  
REQUIRES: -5V @ 3 AMPS  
- 12V @ .5 AMPS.

**FULLY SOCKETED! FEATURES: (Remember, all this on one board!)**

**64K RAM**

Uses industry standard 4116 RAM'S. All 64K is available to the user, our VIDEO and EPROM sections do not make holes in system RAM. Also, very special care was taken in the RAM array PC layout to eliminate potential noise and glitches.

**Z-80 CPU**

Running at 2.5 MHZ. Handles all 4116 RAM refresh and supports Mode 2 INTERRUPTS. Fully buffered and runs 8080 software.

**SERIAL I/O (OPTIONAL)**

Full 2 channels using the Z80 SIO and the SMC 8116 Baud Rate Generator. FULL RS232! For synchronous or asynchronous communication. In synchronous mode, the clocks can be transmitted or received by a modem. Both channels can be set up for either data-communication or data-terminals. Supports mode 2 Int. Price for all parts and connectors: \$49

**BASIC I/O**

Consists of a separate parallel port (Z80 PIO) for use with an ASCII encoded keyboard for input. Output would be on the 80 x 24 Video Display.

**BLANK PC BOARD — \$149**

The blank Big Board PC Board comes complete with full documentation (including schematics), the character ROM, the PFM 3.3 MONITOR ROM, and a diskette with the source of our BIOS, BOOT, and PFM 3.3 MONITOR.

**24 x 80 CHARACTER VIDEO**

With a crisp, flicker-free display that looks extremely sharp even on small monitors. Hardware scroll and full cursor control. Composite video or split video and sync. Character set is supplied on a 2716 style ROM, making customized fonts easy. Sync pulses can be any desired length or polarity. Video may be inverted or true. 5 x 7 Matrix - Upper & Lower Case

**FLOPPY DISC CONTROLLER**

Uses WD1771 controller chip with a TTL Data Separator for enhanced reliability. IBM 3740 compatible. Supports up to four 8 inch disc drives. Directly compatible with standard Shugart drives such as the SA800 or SA801. Drives can be configured for remote AC off-on. Runs CP/M\* 2.2.

**TWO PORT PARALLEL I/O (OPTIONAL)**

Uses Z-80 PIO. Full 16 bits, fully buffered, bi-directional. User selectable hand shake polarity. Set of all parts and connectors for parallel I/O: \$18.95

**REAL TIME CLOCK (OPTIONAL)**

Uses Z-80 CTC. Can be configured as a Counter or Real Time Clock. Set of all parts: \$9.95

**CP/M\* 2.2 FOR BIG BOARD**

The popular CP/M\* D.O.S. to run on Big Board is available for \$159.00.

**PRICE CUT!**

**PFM 3.3 2K SYSTEM MONITOR**

The real power of the Big Board lies in its PFM 3.3 on board monitor. PFM commands include: Dump Memory, Boot CP/M\*, Copy, Examine, Fill Memory, Test Memory, Go To, Read and Write I/O Ports, Disc Read (Drive, Track, Sector), and Search. PFM occupies one of the four 2716 EPROM locations provided. Z-80 is a Trademark of Zilog.

**Digital Research Computers**

(OF TEXAS)

P.O. BOX 401565 • GARLAND, TEXAS 75040 • (214) 271-3538

TERMS: Shipments will be made approximately 3 to 6 weeks after we receive your order. VISA, MC, cash accepted. We will accept COD's (for the Big Board only) with a \$75 deposit. Balance UPS COD. Add \$4.00 shipping.

USA AND CANADA ONLY

# PALOMAR TAKES A BIG

But you still get expert technical advice,  
in-house service repairs and

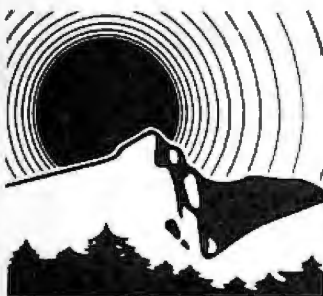

## EPSON

Feature disposable print heads and the new GRAPHTRAX PLUS. All models print bidirectionally and 80 CPS. Mx-80F/T and Mx-100 both have friction and tractor feed. Unsurpassed dot placement accuracy.

- MX-80 (80 col.) ..... CALL
- MX-80 F/T (80 col.) ..... CALL
- MX-100 (136 col.) ..... CALL
- Interface Cards ..... CALL
- Cables ..... CALL

## C. ITOH Pro-Writer

Offers 8 character sizes, 5 different alphabets, proportional spacing, bidirectional, vert and horiz tabs, high resolution graphics, rx9 matrix, 100 CPS 136, col. max. Friction and tractor feed.

- 8510 Serial ..... \$645.
- 8510 Parallel ..... 495.



## NOVEL Image 800

Take advantage of the rock bottom price on this rugged 9x9 dot matrix printer now. 150 CPS, bidirectional tractor feed, 6 or 8 lines per inch. 10, 13.6 16.5 CPI. Serial or parallel interface. 80, 136, 224, col. to a wide 15". 12 different printing modes. Impressive print head life of 200 million char. 11 VFU channels for forms flexibility. Front or bottom feed. Hurry! Priced to sell quickly. **IMAGE 800 ..... \$995.**

## PREMIUM PRINTERS

### COMRITER CR-1 Daisy Wheel

Typewriter quality printing for your word processing computer system. Wide 16.5" paper width, serial or parallel interface. Full control panel MTBF 2,500 hours. Designed with few mechanical parts so high reliability. 17 CPS, 10, 12 and 15 CPI. Bidirectional 132, 158, 198 col. Incredibly low priced.

CR-1-C List \$1195 ..... CALL

### C. ITOH F10 Daisy Wheel

Letter quality printer. Friction feed or bidirectional tractor. 40 or 55 CPS. 136, 163 and variable col.

F10 List \$1795 ..... CALL

## ADLER

### Printer Typewriter

11 or 17.5 CPS, 10, 12, 15 CPI and proportional spacing. 2 line correcting memory, interchangeable print wheels.

SE 1010 List \$1295 ..... \$995.  
Interface Card ..... ADD 350.

## OLYMPIA Printer Typewriter

Letter quality daisy wheel interfaces to Apple, Atari, NEC, TRS80 and RS232 Serial ports. 17.5 CPS, 10, 12 CPI.

ES 100KRO Computer printer  
List \$1690 ..... \$1150.

ES 100 Typewriter Only  
List \$1195 ..... \$895.

Interface Card Only ..... \$250.  
(specify serial or parallel)

I/O Cable (specify serial or parallel) ..... 25.  
Apple Serial Card ..... \$99.

## SMITH-CORONA TP-1 Daisy Wheel

Letter quality price breakthrough! Serial or parallel data interface, 12 CPS, 10 or 12 CPI. Smith-Corona TP-1 List \$895 ..... \$695

## NEC Spinwriters

Letter quality printers: 7700 serial print 55 CPS, 3500 series print 33 CPS. Both series offer up to 128 char., take paper up to 16 in. wide. 7700 series: 136 col. at 10 CPI, 163 col. at 12 CPI. Same for 3500 series plus 204 col. at 15 CPI.

7710/7730 RO w/tractor ..... \$2475.

7720 KSR w/tractor ..... 2850.

3510/3530 RO ..... 1695.

Bidirectional tractor ..... 200.

Push tractor ..... 350.

## New at Palomar!

### STAR MICRONICS DP-8480FT

This new, high powered dot-matrix printer is packed with features to give you unbelievable flexibility, yet look at the low cost! 80 CPS, bidirectional printing, 10, 12, 16.5 CPI, 6, 8, 12 lines per inch. Friction feed and tractor feed. Printing options include block graphics, block and double-width printing and 80, 96, 132 col. Parallel or serial interface. Long life print head: 100 million char. life expectancy.

DP-848FT List \$465 ..... CALL



### MPI 88G 99G 150G

High resolution dot-addressable graphics for Apple. Enhanced "correspondence quality" printing. Tractor and friction feed. Serial and parallel input. Bidirectional printing. 88G, 99G have 10, 12, 16.5 CPI. 150G has 10, 12, 17 CPI. 88G: 100 CPS, 80, 96, 132 col. 99G: 100 CPS, 80, 96, 136 col. 150G: 150 CPS, 136, 163, 226 col., 16" wide.

88G List \$749 ..... \$519.

99G List \$849 ..... 569.

150G List \$1095 ..... 995.

Apple parallel I/O Card/Cable/Disk

with Graphics Prom (Ap-Pak) ..... 145.

IEEE I/O Card ..... 55.

Single Sheet Feeder ..... 25.

QT Cover ..... 30.

## NEC 8023-A Matrix

High resolution dot graphics. Proportional spacing. Correspondent quality printing. Bidirectional tractor and friction feed. 80, 136 col. Greek and math symbols, 100 CPS matrix printer.

8023A Parallel List \$780 ..... \$499.

## OKIDATA

Microline 82A—80/132 col., 120 CPS, 9x9 dot matrix, friction, pin feed or tractor feed (optional) rear and bottom feed. Includes bidirectional/logic seeking and serial parallel or IEEE interfaces. Double width and condensed characters, true lower case descenders and graphics.

82A ..... \$519.

Microline 83A—132/232 col., 120 CPS, handles forms up to 15 in. wide, plus all the features of the 82A.

83A ..... \$745.

Microline 84SP—132/232 col., 200 CPS with full dot graphics built-in. Takes forms up to 15 in. wide, plus all the features of the 83A.

84SP ..... \$1150.

# PALOMAR

Computer Products

WRITE OR CALL (714) 744-7314

910-105 W. San Marcos Blvd., Dept. 9B, San Marcos, CA 92069

# BYTE OUT OF PRICES

fast response on orders,  
guaranteed satisfaction



## APPLE AND ACCESSORIES

Apple II Plus & 48K...CALL	A/D Card.....\$99.
Disk II	ROM Plus.....129.
Wcontrol DOS 3.3...CALL	Keyboard Filter ROM...49.
Disk Add-On...CALL	CPS Multifunction Card...179.
280 Softcard.....\$299.	Paymar L/C Adapt...19/32.
16K RAMcard.....99.	Videx Videoterm.....299.
Par. Printer Card.....89.	Dma Fan.....39.
Serial Card.....109.	TG Game Paddles.....32.
Clock Calendar Card.....99.	TG Joy Stick.....47.
IEEE Card.....249.	Select A Port.....47.

## APPLE SOFTWARE

BUSINESS		GAMES	
Financial Partner.....\$191.	Raster Blaster.....\$24.	Air Traffic Controller.....9.	Temple of Apehal.....31.
Pro Easy Writer.....137.	Easy Writer 4C Col.....78.	Destinies of Ryn.....15.	Monic's Tower.....15.
Word Star (Req. SC).....220.	Super Sort (Req. SC).....118.	Rescue at Rigel.....23.	Crash, Crumble & Chomp.....23.
Mail Merger.....75.	Data Star (Req. SC).....170.	Hell Fire Warrior.....31.	Upper Reaches of Apehal.....15.
Spell Star (Req. SC).....115.	Calc Star (Req. SC).....115.	The Keys to Adcheron.....15.	Snack Attack.....23.
Super Text II.....117.	The Address Book.....38.	The Prisoner.....23.	Zork I.....31.
Form Letter Module.....78.	Vsatile.....229.	Zork II.....31.	Robot Wars.....31.
Desktop Plan II.....275.	Desktop Plan II.....229.	Three Mile Island.....31.	A.B.M.....19.
Visitrend / Visplot.....185.	Visitrend / Visplot.....275.	Wizard and Princes.....25.	Castle Wolfenstein.....23.
Visitrend.....229.	Visitrend.....89.	Wizard and Princes.....25.	Missile Defense.....23.
Visitrend 3.3.....229.	Infotory.....198.	Cranston Manor.....27.	Warp Destroyer.....23.
Superspell (Req. SC).....435.	Word Processor (Req. SC).....225.	Cyber Strike.....31.	Star Warrior.....31.
PERSONAL/HOME		Phantoms Five.....\$24.	Space Eggs.....24.
Typing Tutor.....\$19.	Elementary Math.....31.	Pulsar II.....24.	Autobahn.....24.
Personal Filing System.....74.	Personal Report System.....74.	Orbitron.....24.	Gamma Goblins.....24.
Algebra I.....31.	Compu-Math: Arith. Skill.....39.	Gorgon.....32.	Sneakers.....32.
Compu-Math: Fractions.....31.	Compu-Math: Decimals.....31.	Epoch.....28.	Cops and Robbers.....28.
Compu-Math: Lists (Req. Disk).....23.	MISC	Outpost.....24.	Dark Forest.....24.
Applesoft Compiler.....\$144.	Basic Computer.....27.	Beer Run.....24.	Hedron.....28.
Apple-Doc.....41.	D.B. Master.....189.	Tweeps.....24.	Snake Byte.....24.
E.B. Utility Pack.....81.	E.Z. Draw 3.3.....40.	Borg.....24.	Computer Football.....24.
Pascal Graph. Ed.....79.	Adventure #1,2,3(D).....\$32.	Minibaur.....28.	Kebul Spy.....28.
Adventure #4,5,6(D).....32.	Adventure #7,8,9(D).....32.	Cyclod.....24.	Jellyfish.....24.
Adventure #10,11,12(D).....32.	Atari Mailing List(D).....19.	Bendits.....28.	Lemmings.....24.
Text Wizard.....79.	Compu-Math/Frac.(D).....32.	Fly Wars.....24.	
	Compu-Math/Frac.(C).....24.		
	Compu-Math/Dec.(D).....32.		
	Compu-Math/Dec.(C).....24.		
	Letter Perfect(D).....119.		
	Mail Merger/Utility(D).....24.		

## ATARI SOFTWARE

Adventure #1,2,3(D).....\$32.	Compu-Math/Frac.(D).....32.
Adventure #4,5,6(D).....32.	Compu-Math/Frac.(C).....24.
Adventure #7,8,9(D).....32.	Compu-Math/Dec.(D).....32.
Adventure #10,11,12(D).....32.	Compu-Math/Dec.(C).....24.
Atari Mailing List(D).....19.	Letter Perfect(D).....119.
Text Wizard.....79.	Mail Merger/Utility(D).....24.

## APPLE GRAPHICS CARD



Better Than Grappler!

- Dump Screen 1 or 2
  - Double size • Emphasize
  - Inverse or normal • Rotate
  - Set left margin or center image.
- This improved intelligent printer interface card enables you to print either of the Apple's h-res. screens with just a few keystrokes. Compatible with Epson, Nec, C. Itoh, Anadex, Centronics, Okidata, IDS, 15 commands.  
Genie Interface Card..... 99.

## NEC PC-8000 Series Microcomputer



- Z-80A CPU 4 MHz
  - 5 user programmable function keys
  - 82 keys with numeric keypad
  - 160 x 100 resolution
  - 80 character screen
- PC-800 1A Microcomputer w/32K RAM..... \$750.  
PC-8012A I/O Unit with 32K RAM Expansion slots..... 480.  
PC-8031A Dual Mini-Disk Drive Unit.. 750.

## MODEMS

## UDS, HAYES NOVIATION CAT

- UDS 103 LP, direct.....\$169.  
103 JLP Auto Answer.....209.  
202 LP 1200 BAUD.....259.  
NOVIATION CAT, acoustic.....145.  
D-Cat, direct.....155.  
Auto Cat.....219.  
Apple Cat.....275.  
HAYES S100 Micromodem.....349.  
Apple Micromodem.....299.  
Smart Modem.....245.

## ANCHOR

- Automation only  
Signalman Mark 1 \$99.  
RS232 300 BAUD, Bell 103 compatible, Automatic selection of originate or answer modes.  
Signalman Mark 1..... \$99.

## RIBBONS

- NEC7700.....\$77/Doz.  
Qume.....45/Doz.  
Diablo.....66/Doz.  
Anadex.....135/6 ea.  
Tritel.....95/Doz.  
TI/DEC/TTY.....45/Doz.  
Epson 80/FT.....12.99  
MPI/Axdom/Base 2.....13.95/ea.

## CENTRONICS AND OSBORNE CABLES

- Centronics to Osborne 6 ft..... \$30.  
Centronics to Centronics 6 ft.....30.

## CENTRONICS AND IBM CABLES

- Centronics to IBM 10 ft..... \$30.  
RS232 CABLES  
4 wire male-male 10 ft..... \$25.  
9 wire male-male 10 ft.....30.  
4 wire male-female 10 ft.....25.  
9 wire male-female 10 ft.....30.

## RS-232 SWITCH BOX

- RS232 Switch Box (Use 2 terminals or printers from one output port).... 109.

## VIDEO TERMS, MONITORS

### COMREX



- CR-5500—Monochrome Display Monitor—12" green screen, 80 char. wide x 24 rows. CR-5500 List \$179.....\$129.  
CR-6500 Color Display Monitor—13" in-line color. Hi-Resolution 260H x 300V. CR-6500 List \$445..... \$339.  
CR-6600 Color Display Monitor—13" in-line color with RGB signal for higher resolution graphics. 380H x 240V. CR-6600 List \$619..... \$439.  
Ampex Dialog 80..... \$995.  
Ampex Dialog 30..... 795.  
Televideo 920C..... 845.  
Televideo 950..... 995.  
SOROC IQ 120..... 499.  
Zenith 12" Green..... 119.  
NEC 12" Green..... 169.

Just arrived

## TAXAN Video Monitors

KG-12N—Monochrome Display Monitor—12" green screen, 2000 char. display, 800 line horizontal resolution. Better than 18 MHz bandwidth. KG-12N. List \$169..... CALL  
RGB Vision 1—Color Display Monitor—12" screen, 380 lines horizontal resolution, 2000 char. display, 16 colors for Apple III and IBM, no interface modules needed. Compatible with Apple II using Taxan RGB-II card. 18MHz bandwidth. RGB Vision 1 List \$399..... CALL

## FAN FOLD PAPER

- (Prices F.O.B. S.P.)  
9½x11-20#Bond White (2700 ct.)... \$29.  
14½x11-20#Bond White (2400 ct.)...37.  
14½x11-20#Bond 1/2" Green Bar (2400 ct.).....37.

TERMS OF SALE: Cash, check, money order, bank wire transfer, credit card or purchase orders from qualified firms and institutions. Please include telephone number with order and expiration date on credit card orders. California residents add 6% sales tax. Advertised prices are for prepaid orders F.O.B. shipping point. Add 3% or \$3 minimum for shipping in U.S. Pricing and availability subject to change without notice.

WE CARRY  
LOTS MORE THAN  
LISTED HERE!  
INQUIRIES WELCOME.

**PALOMAR**  
Computer Products



**4116** 16K DYNAMIC 250NS **8/\$11<sup>95</sup>** SET

**2114** 1Kx4 STATIC LOW POWER 200NS **8/\$15<sup>95</sup>** SET

ALL MERCHANDISE 100% GUARANTEED!

CALL US FOR VOLUME QUOTES

**STATIC RAMS**

2101	256 x 4 (450ns)	1.95
5101	256 x 4 (450ns) (cmos)	3.95
2102-1	1024 x 1 (450ns)	.89
2102L-4	1024 x 1 (450ns) (LP)	1.29
2102L-2	1024 x 1 (250ns) (LP)	1.69
2111	256 x 4 (450ns)	2.99
2112	256 x 4 (450ns)	2.99
2114	1024 x 4 (450ns)	8/14.95
2114L-4	1024 x 4 (450ns) (LP)	8/15.25
2114L-3	1024 x 4 (300ns) (LP)	8/15.45
2114L-2	1024 x 4 (200ns) (LP)	8/15.95
2147	4096 x 1 (55ns)	9.95
TMS4044-4	4096 x 1 (450ns)	3.49
TMS4044-3	4096 x 1 (300ns)	3.99
TMS4044-2	4096 x 1 (200ns)	4.49
MK4118	1024 x 8 (250ns)	9.95
TMM2016-200	2048 x 8 (200ns)	5.95
TMM2016-150	2048 x 8 (150ns)	6.95
TMM2016-100	2048 x 8 (100ns)	7.95
HM6116-4	2048 x 8 (200ns) (cmos)	6.95
HM6116-3	2048 x 8 (150ns) (cmos)	7.10
HM6116-2	2048 x 8 (120ns) (cmos)	9.95
HM6116LP-4	2048 x 8 (200ns) (cmos)(LP)	8.75
HM6116LP-3	2048 x 8 (150ns) (cmos)(LP)	8.95
HM6116LP-2	2048 x 8 (120ns) (cmos)(LP)	12.95
Z-6132	4096 x 8 (300ns) (Qstat)	34.95

LP = Low Power Qstat = Quasi-Static

**DYNAMIC RAMS**

TMS4027	4096 x 1 (250ns)	2.50
MK4106	8192 x 1 (200ns)	1.95
MMS298	8192 x 1 (250ns)	1.85
4116-300	16384 x 1 (300ns)	8/11.75
4116-250	16384 x 1 (250ns)	8/11.95
4116-200	16384 x 1 (200ns)	8/13.95
4116-150	16384 x 1 (150ns)	8/15.95
4116-120	16384 x 1 (120ns)	8/29.95
2118	16384 x 1 (150ns) (5v)	4.95
MK4816	2048 x 8 (300ns) (5v)	24.95
4164-200	65536 x 1 (200ns) (5v)	7.25
4164-150	65536 x 1 (150ns) (5v)	8.25

5V single 5 volt supply

**EPROMS**

1702	256 x 8 (1us)	4.50
2708	1024 x 8 (450ns)	3.95
2758	1024 x 8 (450ns) (5v)	9.95
2716	2048 x 8 (450ns) (5v)	3.95
2716-1	2048 x 8 (350ns) (5v)	7.95
TMS2716	2048 x 8 (450ns)	9.95
TMS2532	4096 x 8 (450ns) (5v)	7.95
2732	4096 x 8 (450ns) (5v)	8.95
2732-250	4096 x 8 (250ns) (5v)	12.95
2732-200	4096 x 8 (200ns) (5v)	16.95
2764	8192 x 8 (450ns) (5v)	16.95
2764-250	8192 x 8 (250ns) (5v)	18.95
2764-200	8192 x 8 (200ns) (5v)	19.95
TMS2584	8192 x 8 (450ns) (5v)	24.95
MC86764	8192 x 8 (450ns) (5v)(24 pin) call	

5v - Single 5 Volt Supply

**EPROM ERASERS**

	Timer	Capacity Chip	Intensity (uW/Cm <sup>2</sup> )	
PE-14		6	5,200	83.00
PE-14T	X	6	5,200	119.00
PE-24T	X	9	6,700	175.00
PL-265T	X	20	6,700	255.00
PR-125T	X	16	15,000	349.00
PR-320	X	32	15,000	595.00

**DISC CONTROLLERS**

1771	20.95
1791	29.95
1793	38.95
1795	54.95
1797	54.95
5843	34.95
8272	39.95
UPD765	39.95
1691	18.85
2143	16.95

**INTERFACE**

8T26	1.89
8T28	2.49
8T95	.99
8T96	.99
8T97	.99
8T98	.99
DM8131	2.95
DP8304	2.29
DS8835	1.99
DS8836	.99

**MISC.**

3242	7.95
3341	4.95
MC3470	4.95
MC3480	9.00
11C90	13.95
95H90	7.95
2513-001 UP	9.95
2513-002 LOW	9.95

**SOUND CHIPS**

76477	3.95
76489	8.95
AY3-8910	12.95
MC3340	1.49

**CRT CONTROLLERS**

6845	14.95
68B45	35.95
HD46505SP	15.95
6847	12.25
68047	24.95
8275	29.95
7220	99.95
CRT5027	39.95
CRT5037	49.95
TMS9918A	39.95

**BIT-RATE GENERATORS**

MC14411	11.95
BR1941	11.95
4702	12.95
COM5016	16.95
COM8116	10.95
MMS307	10.95

**UARTS**

AY3-1014	6.95
AY5-1013	3.95
PT1472	9.95
TR1602	3.95
2350	9.95
2651	18.95
TMS6011	5.95
IM6402	7.95
IM6403	8.95
INS8250	14.95

**KEYBOARD CHIPS**

AY5-2376	11.95
AY5-3600	11.95
74C922	5.25
74C923	5.50

**CLOCK CIRCUITS**

MMS314	4.95
MMS369	3.95
MMS375	4.95
MMS8167	8.95
MMS8174	11.95
MSM5832	8.95

**Z-80 2.5 Mhz**

Z80-CPU	3.95
Z80-CTC	5.95
Z80-DART	15.25
Z80-DMA	17.50
Z80-PIO	5.75
Z80-SIO/0	18.50
Z80-SIO/1	18.50
Z80-SIO/2	18.50
Z80-SIO/3	16.95

**4.0 Mhz**

Z80A-CPU	6.00
Z80A-CTC	8.65
Z80A-DART	16.75
Z80A-DMA	27.50
Z80A-PIO	6.00
Z80A-SIO/0	22.50
Z80A-SIO/1	22.50
Z80A-SIO/2	22.50
Z80A-SIO/3	19.95

**6.0 Mhz**

Z80B-CPU	17.95
Z80B-CTC	15.50
Z80B-PIO	15.50

**ZILOG**

Z6132	34.95
Z8671	39.95

**CRYSTALS**

32.768 khz	1.95
1.0 mhz	4.95
1.8432	4.95
2.0	3.95
2.097152	3.95
2.4576	3.95
3.2768	3.95
3.579535	3.95
4.0	3.95
5.0	3.95
5.0688	3.95
5.185	3.95
5.7143	3.95
6.0	3.95
6.144	3.95
6.5536	3.95
8.0	3.95
10.0	3.95
14.31818	3.95
15.0	3.95
16.0	3.95
18.0	3.95
18.432	3.95
20.0	3.95
22.1184	3.95
32.0	3.95

**DATA ACQUISITION**

ADC0800	15.55
ADC0804	4.95
ADC0809	5.25
ADC0817	10.95
DAC0800	4.95
DAC0806	2.25
DAC0808	4.95
DAC1020	8.25
DAC1022	8.25
MC1408L6	2.25
MC1408L8	4.95

**8000**

8035	7.25
8039	7.95
INS-8060	17.95
INS-8073	29.95
8000	3.95
8085	7.95
8085A-2	11.95
8086	29.95
8087	CALL
8088	39.95
8089	69.95
8155	7.95
8156	8.95
8185	29.95
8185-2	39.95
8741	39.95
8748	29.95
8755	32.00

**8200**

8202	29.95
8203	39.95
8205	3.50
8212	1.85
8214	3.85
8216	1.80
8224	2.50
8226	1.80
8228	4.90
8237	19.95
8238	4.95
8243	4.45
8250	14.95
8251	4.75
8253	8.25
8253-5	8.85
8255	4.75
8255-5	5.25
8257	8.50
8257-5	8.95
8259	6.90
8259-5	7.50
8271	39.95
8272	39.95
8275	29.95
8279	9.50
8279-5	10.00
8282	6.65
8283	6.65
8284	5.70
8286	6.65
8287	6.50
8288	25.00
8289	49.95

**FUNCTION GENERATORS**

MC4024	3.95
LM566	1.49
XR2206	3.75
8038	3.95

**INTERSIL**

ICL7103	9.50
ICL7106	9.95
ICL7107	12.95
ICL8038	3.95
MC1707A	5.59
ICM7208	15.95

**6800**

68000	99.95
6800	4.95
6802	10.95
6808	13.90
6809E	19.95
6809	12.95
6810	2.95
6820	4.95
6821	4.95
6828	14.95
6840	12.95
6843	34.95
6844	25.95
6845	14.95
6847	12.25
6850	3.45
6852	5.75
6860	10.95
6862	11.95
6865	6.95
6880	2.95
6883	24.95
68047	24.95
68488	19.95

**8800 - 1MHZ**

68B00	10.95
68B02	22.25
68B09E	29.95
68B09	29.95
68B10	7.95
68B21	12.95
68B45	35.95
68B50	12.95

**8800 - 2 MHZ**

**6500 1 MHZ**

6502	5.95
6504	6.95
6505	8.95
6507	9.95
6520	4.35
6522	8.75
6532	11.25
6545	22.50
6551	11.95

**2 MHZ**

6502A	9.95
6522A	11.70
6532A	12.40
6545A	28.50
6551A	12.95

**3 MHZ**

6502B	14.95
-------	-------

**EXAR**

XR 2206	3.75
XR 2207	3.85
XR 2208	3.90
XR 2211	5.25
XR 2240	3.25

**9000 SERIES**

9316	1.00
8334	2.50
9368	3.95
9401	9.95
9601	.75
9602	1.50
96S02	1.95

**VISIT OUR RETAIL STORE**

**HOURS: M-F, 9-5; Sat. 11-3**

PLEASE USE YOUR CUSTOMER NUMBER WHEN ORDERING

TERMS: For shipping include \$2 for UPS Ground or \$3 for UPS Blue Label Air. Items over 5 pounds require additional shipping charges. Foreign orders, include sufficient amount for shipping. There is a \$10 minimum order. Bay Area and Los Angeles Counties add 6% Sales Tax. Other California residents add 6% Sales Tax. We reserve the right to substitute manufacturer. Not responsible for typographical errors. Prices are subject to change without notice. We will match or beat any competitor's price provided it is not below our cost.

**JDR MICRODEVICES, INC.**

1224 S. Bascom Avenue  
San Jose, CA 95128

800-538-5000 • 800-662-6279 (CA)  
(408) 995-5430 • Telex 171-110



**2716** 16K EPROMS **\$3<sup>95</sup>** EACH

ALL MERCHANDISE 100% GUARANTEED!

**2732** 32K EPROMS **\$6<sup>95</sup>** EACH

CALL US FOR VOLUME QUOTES

**74LS00**

74LS00	.25	74LS06	.40	74LS169	1.75	74LS323	2.75
74LS01	.25	74LS90	.65	74LS170	1.75	74LS324	1.75
74LS02	.25	74LS91	.89	74LS173	.80	74LS352	1.55
74LS03	.25	74LS92	.70	74LS174	.85	74LS353	1.55
74LS04	.25	74LS93	.65	74LS175	.95	74LS363	1.35
74LS05	.25	74LS95	.85	74LS181	2.15	74LS364	1.95
74LS08	.35	74LS96	.95	74LS189	9.95	74LS365	.95
74LS09	.35	74LS107	.40	74LS190	1.00	74LS366	.95
74LS10	.25	74LS109	.40	74LS191	1.00	74LS367	.70
74LS11	.35	74LS112	.45	74LS192	.85	74LS368	.70
74LS12	.35	74LS113	.45	74LS193	.95	74LS373	1.75
74LS13	.45	74LS114	.50	74LS194	1.00	74LS374	1.75
74LS14	1.00	74LS122	.45	74LS195	.95	74LS377	1.45
74LS15	.35	74LS123	.95	74LS196	.85	74LS378	1.18
74LS20	.25	74LS124	2.99	74LS197	.85	74LS379	1.35
74LS21	.35	74LS125	.95	74LS221	1.20	74LS385	1.90
74LS22	.25	74LS126	.85	74LS240	1.29	74LS386	.85
74LS26	.35	74LS132	.75	74LS241	1.28	74LS390	1.90
74LS27	.35	74LS133	.89	74LS242	1.85	74LS393	1.90
74LS28	.35	74LS136	.55	74LS243	1.85	74LS395	1.65
74LS30	.25	74LS137	.99	74LS244	1.29	74LS399	1.90
74LS32	.35	74LS138	.75	74LS245	1.90	74LS424	2.75
74LS33	.55	74LS139	.75	74LS247	.75	74LS447	.37
74LS37	.55	74LS145	1.20	74LS248	1.25	74LS490	1.95
74LS38	.35	74LS147	2.49	74LS249	.99	74LS624	3.99
74LS40	.35	74LS148	1.35	74LS251	1.30	74LS668	1.69
74LS42	.55	74LS151	.75	74LS253	.85	74LS669	1.89
74LS47	.75	74LS153	.75	74LS257	.85	74LS670	2.20
74LS48	.75	74LS154	2.35	74LS258	.85	74LS674	9.65
74LS49	.75	74LS155	1.15	74LS259	2.85	74LS682	3.20
74LS51	.25	74LS156	.95	74LS260	.65	74LS683	3.20
74LS54	.35	74LS157	.75	74LS266	.55	74LS684	3.20
74LS55	.35	74LS158	.75	74LS273	1.65	74LS685	3.20
74LS53	1.25	74LS160	.90	74LS275	3.35	74LS688	2.40
74LS73	.40	74LS161	.95	74LS278	.55	74LS689	3.20
74LS74	.45	74LS162	.95	74LS280	1.98	74LS783	24.95
74LS75	.50	74LS163	.95	74LS283	1.00	81LS95	1.69
74LS76	.40	74LS164	.95	74LS290	1.25	81LS96	1.69
74LS78	.50	74LS165	.95	74LS293	1.85	81LS97	1.69
74LS83	.75	74LS166	2.40	74LS295	1.05	81LS98	1.69
74LS85	1.15	74LS168	1.75	74LS298	1.20	25LS2521	2.80
						25LS2569	4.25

**IC SOCKETS**

1-99	100
8 pin ST	.13 .11
14 pin ST	.15 .12
16 pin ST	.17 .13
18 pin ST	.20 .18
20 pin ST	.29 .27
22 pin ST	.30 .27
24 pin ST	.30 .27
28 pin ST	.40 .32
40 pin ST	.49 .39
<b>ST SOLDERTAIL</b>	
8 pin WW	.59 .49
14 pin WW	.69 .52
16 pin WW	.69 .58
18 pin WW	.99 .90
20 pin WW	1.09 .98
22 pin WW	1.39 1.28
24 pin WW	1.49 1.35
28 pin WW	1.69 1.49
40 pin WW	1.99 1.80
<b>WW WIREWRAP</b>	
16 pin ZIF	6.75 call
24 pin ZIF	9.95 call
<b>ZIF TEXT TOOL</b> (Zero Insertion Force)	

**CONNECTORS**

RS232 MALE	3.25
RS232 FEMALE	3.75
RS232 FEMALE	3.75
RIGHT ANGLE	5.25
RS232 HOOD	1.25
S-100 ST	3.95
S-100 WW	4.95

**DIP SWITCHES**

4 POSITION	.85
5 POSITION	.90
6 POSITION	.90
7 POSITION	.95
8 POSITION	.95

**7400**

7400	.19	74132	.45
7401	.19	74136	.50
7402	.19	74141	.65
7403	.19	74142	2.95
7404	.19	74143	2.95
7405	.25	74145	.60
7406	.29	74147	1.75
7407	.29	74148	1.20
7408	.24	74150	1.35
7409	.19	74151	.65
7410	.19	74152	.65
7411	.25	74153	.55
7412	.30	74154	1.40
7413	.35	74155	.75
7414	.55	74156	.65
7415	.25	74157	.65
7417	.25	74159	1.55
7420	.19	74160	.85
7421	.35	74161	.70
7422	.29	74162	.85
7423	.29	74163	.85
7425	.29	74164	.85
7426	.29	74165	.85
7427	.29	74166	1.00
7428	.45	74167	2.95
7430	.19	74170	1.65
7432	.29	74172	5.95
7433	.45	74173	.75
7437	.29	74174	.89
7438	.29	74175	.89
7440	.19	74176	.89
7442	.49	74177	.75
7443	.65	74178	1.15
7444	.69	74179	1.75
7445	.69	74180	.75
7446	.59	74181	2.25
7447	.69	74182	.75
7448	.69	74184	2.00
7450	.19	74185	2.00
7451	.23	74186	18.50
7453	.23	74190	1.15
7454	.23	74191	1.15
7460	.23	74192	.79
7470	.35	74193	.79
7472	.29	74194	.85
7473	.34	74195	.85
7474	.35	74196	.79
7475	.49	74197	.75
7478	.35	74198	1.35
7480	.59	74199	1.35
7481	1.10	74221	1.35
7482	.95	74246	1.35
7483	.50	74247	1.25
7485	.65	74248	1.85
7486	.35	74249	1.95
7489	4.95	74251	.75
7490	.35	74259	2.25
7491	.40	74265	1.35
7492	.50	74273	1.95
7493	.49	74276	1.25
7494	.65	74279	.75
7495	.55	74283	2.00
7496	.70	74284	3.75
7497	2.75	74285	3.75
74100	1.75	74290	.95
74107	.30	74293	.75
74109	.45	74298	.85
74110	.45	74351	2.25
74111	.55	74365	.65
74118	1.55	74366	.65
74120	1.20	74367	.65
74121	.29	74368	.65
74122	.45	74376	2.20
74123	.55	74390	1.75
74125	.45	74393	1.35
74126	.45	74425	3.15
74128	.55	74428	.85
		74490	2.55

**CMOS**

4000	.35	4528	1.25
4001	.35	4531	.95
4002	.25	4532	1.95
4006	.95	4538	1.95
4007	.29	4539	1.95
4008	.95	4543	2.70
4009	.45	4555	.95
4010	.45	4556	.95
4011	.35	4581	1.95
4012	.25	4582	1.95
4013	.45	4584	.95
4014	.95	4585	.95
4015	.95	4702	12.95
4016	.45	74C00	.35
4017	1.15	74C02	.35
4018	.95	74C04	.35
4019	.45	74C08	.35
4020	.95	74C10	.35
4021	.95	74C14	1.50
4022	1.15	74C20	.35
4023	.35	74C30	.35
4024	.75	74C32	.50
4025	.35	74C42	1.75
4026	1.65	74C48	1.20
4027	.65	74C73	.65
4028	.80	74C74	.85
4029	.95	74C76	.80
4030	.45	74C83	1.95
4034	2.95	74C85	1.95
4035	.85	74C86	.95
4040	.95	74C89	4.50
4041	1.25	74C90	1.75
4042	.75	74C93	1.75
4043	.85	74C95	1.75
4044	.85	74C107	1.00
4046	.95	74C150	5.75
4047	.95	74C151	2.25
4049	.55	74C154	3.25
4050	.55	74C157	1.75
4051	.95	74C160	2.00
4053	.95	74C161	2.00
4060	1.45	74C162	2.00
4066	.75	74C163	2.00
4068	.40	74C164	2.00
4069	.35	74C165	2.00
4070	.35	74C173	2.00
4071	.30	74C174	2.25
4072	.30	74C175	2.25
4073	.30	74C192	2.25
4075	.30	74C193	2.25
4076	.95	74C195	2.25
4078	.30	74C200	5.75
4081	.30	74C221	2.25
4082	.30	74C373	2.75
4085	.95	74C374	2.75
4086	.95	74C901	.80
4093	.95	74C902	.85
4098	2.49	74C903	.85
4099	1.95	74C905	10.95
14409	12.95	74C906	.95
14410	12.95	74C907	1.00
14411	11.95	74C908	2.00
14412	12.95	74C909	2.75
14419	4.95	74C910	9.95
4502	.95	74C911	10.00
4503	.65	74C912	10.00
4508	1.95	74C914	1.95
4510	.95	74C915	2.00
4511	.95	74C918	2.75
4512	.95	74C920	17.95
4514	1.25	74C921	15.95
4515	2.25	74C922	5.95
4516	1.55	74C923	5.95
4518	1.25	74C925	6.75
4519	1.25	74C926	7.95
4520	1.25	74C927	7.95
4522	1.25	74C928	7.95
4526	1.25	74C929	19.95
4527	1.95	74C930	19.95

**Prices Slashed!**  
**74S00**

74S00	.32	74S163	1.95
74S02	.35	74S168	3.95
74S03	.35	74S169	3.95
74S04	.35	74S174	1.09
74S05	.35	74S175	1.09
74S08	.35	74S181	3.95
74S09	.40	74S182	2.95
74S10	.35	74S188	1.95
74S11	.35	74S189	6.95
74S15	.35	74S194	1.49
74S20	.35	74S195	1.49
74S22	.35	74S196	1.49
74S30	.35	74S197	1.49
74S32	.40	74S201	6.95
74S37	.68	74S225	7.95
74S38	.65	74S240	2.20
74S40	.35	74S241	2.20
74S51	.35	74S244	2.20
74S64	.40	74S251	.95
74S65	.40	74S253	.95
74S74	.50	74S257	.95
74S85	1.99	74S258	.95
74S86	.50	74S260	.79
74S112	.50	74S274	19.95
74S113	.50	74S275	19.95
74S114	.55	74S280	2.25
74S124	2.75	74S28	

# FLOPPY DISK DRIVE

## LINEAR

LM301	.34	LM350K	5.60	NE570	4.75	LM1800	2.99
LM301H	.79	LM350T	4.60	NE571	3.95	LM1812	8.25
LM307	.45	LM358	.98	NE592	2.75	LM1815	5.20
LM308	.98	LM359	1.79	LM703	.89	LM1818	2.90
LM308H	1.15	LM376	3.75	LM709	.59	LM1820	3.50
LM309H	1.95	LM377	2.29	LM710	.75	LM1830	3.50
LM309K	1.49	LM378	2.50	LM711	.79	LM1871	5.49
LM310	1.75	LM379	4.50	LM723	.49	LM1872	5.49
LM311	.64	LM380	1.29	LM723H	.55	LM1877	3.25
LM311H	.89	LM380N-8	1.10	LM733	.98	LM1889	2.49
LM312H	1.75	LM381	1.60	LM741N-8	.35	LM1896	1.75
LM317K	3.95	LM382	1.80	LM741N-14	.35	LM2877	2.05
LM317T	1.95	LM383	1.95	LM741H	.40	LM2878	2.25
LM318	1.49	LM384	1.95	LM747	.79	LM2900	.85
LM318H	1.59	LM386	1.50	LM748	.59	LM2901	1.00
LM319H	1.25	LM387	1.40	LM1014	2.75	LM3900	.59
LM319	1.25	LM389	1.35	LM1303	1.95	LM3905	1.25
LM320 (see 7900)	LM390	1.95	LM1304	1.19	LM3909	.98	
LM322	1.85	LM392	.89	LM1305	1.49	LM3911	2.25
LM323K	4.95	LM394H	4.80	LM1307	.85	LM3914	3.95
LM324	.59	LM399H	5.00	LM1310	2.90	LM3915	3.95
LM329	.89	NE531	3.75	MC1330	1.89	LM3916	3.95
LM331	3.95	NE536	6.00	MC1349	1.89	MC4024	3.95
LM334	1.30	NE555	.39	MC1350	1.29	MC4044	4.50
LM335	1.40	NE556	.59	MC1358	1.79	RC4136	1.25
LM336	1.75	NE558	1.50	LM1414	1.59	RC4151	3.95
LM337K	3.95	NE561	19.95	LM1456	.69	LM4250	1.75
LM337T	2.95	NE562	6.00	LM1488	.99	LM4500	3.25
LM338K	6.95	NE564	3.95	LM1489	.99	LM13080	1.29
LM339	.99	LM565	.99	LM1496	.85	LM13600	1.49
LM340 (see 7800)	LM566	1.49	LM1556H	3.10	LM13700	1.49	
LM346	1.20	LM567	1.29				

H TO-5 CAN

T TO-220

K TO-3

## RCA

CA 3010	.99	CA 3081	1.65
CA 3013	2.00	CA 3082	1.65
CA 3023	2.75	CA 3083	1.55
CA 3035	2.49	CA 3086	.80
CA 3039	1.29	CA 3089	2.99
CA 3046	1.25	CA 3096	3.49
CA 3053	1.45	CA 3130	1.30
CA 3059	2.80	CA 3140	1.15
CA 3060	2.90	CA 3146	1.85
CA 3065	1.75	CA 3160	1.19
CA 3080	1.10	CA 3401	.59
		CA 3600	3.45

## TI

TL494	4.20	75365	1.95
TL496	1.65	75450	.59
TL497	3.25	75451	.39
75107	1.49	75452	.39
75110	1.95	75453	.39
75150	1.95	75454	.39
75154	1.95	75491	.79
75188	1.25	75492	.79
75189	1.25	75493	.89
		75494	.69

## BI FET

TL071	.79	TL084	2.19
TL072	1.19	LF347	2.19
TL074	2.19	LF351	.60
TL081	.79	LF353	1.00
TL082	1.18	LF355	1.10
TL083	1.19	LF356	1.10
		LF357	1.40

## VOLTAGE REGULATORS

7805T	.89	7905T	.99
7806T	.89	7908T	.99
7812T	.89	7912T	.99
7815T	.89	7915T	.99
7824T	.89	7924T	.99
7805K	1.39	7905K	1.49
7812K	1.39	7912K	1.49
7815K	1.39	7915K	1.49
7824K	1.39	7924K	1.49
78L05	.69	79L05	.79
78L12	.69	79L12	.79
78L15	.69	79L15	.79
78H05K	9.95	LM323K	4.95
78H12K	9.95	UA78S40	1.95

T TO-220 K TO-3  
L TO-92

**STOP BY AND VISIT OUR RETAIL STORE**  
HOURS:  
MON.-FRI. 9-5, SAT. 11-3

## "JDR SUPER SPECIALS"

### MEMORY CLEARANCE

<b>2k x 8</b>	<b>STATIC</b>	<b>\$5<sup>95</sup> EA.</b>	<b>DYNAMIC</b>	
TMM2016-200NS			64k x 1 4164-200NS	<b>\$7<sup>25</sup></b>
<b>1k x 1</b>		<b>100/\$7<sup>5</sup></b>	4k x 1 4027-250NS	<b>\$1<sup>95</sup></b>
2102L-450NS				

## CPU SALE

### 8 BIT

Z-80 CPU 2MHZ	\$3 <sup>95</sup>	(10/ 3.75 EA)
6502 1 MHZ	\$5 <sup>95</sup>	(10/ 5.75 EA)
6809 INT. CLOCK	\$12 <sup>95</sup>	(10/11.25 EA)

### 16 BIT

8086	\$29 <sup>95</sup>
68000 8MHZ	\$99 <sup>95</sup>

### BAUD-RATE GENERATORS

MC14411	7.95	10/7.25
1.8432 CRYSTAL	4.95	
4702	8.95	10/7.95
2.4576 CRYSTAL	4.95	

### TRANSISTORS

PN2222	1000/69.00
2N3904	1000/69.00
2N3906	1000/69.00

### IC SOCKETS LOW PROFILE SOLDER TAIL

#### HIGH RELIABILITY DUAL SIDE WIPE STYLE

	100 pcs	1000 pcs
8 pin	.08	.075
14 pin	.09	.085
16 pin	.09	.085
18 pin	.12	.110
24 pin	.20	.150
40 pin	.22	.190

**SALE ENDS SEPTEMBER 30, 1982**

## JDR MICRODEVICES, INC.

1224 S. Bascom Avenue  
San Jose, CA 95128

800-538-5000 • 800-662-6279 (CA)  
(408) 995-5430 • Telex 171-110

### VISIT OUR RETAIL STORE

HOURS:  
M-F. 9-5; Sat. 11-3

PLEASE USE YOUR CUSTOMER NUMBER WHEN ORDERING

TERMS: For shipping include \$2 for UPS Ground or \$3 for UPS Blue Label Air. Items over 5 pounds require additional shipping charges. Foreign orders, include sufficient amount for shipping. There is a \$10 minimum order. Bay Area and Los Angeles Counties add 8% Sales Tax. Other California residents add 6% Sales Tax. We reserve the right to substitute manufacturer. Not responsible for typographical errors. Prices are subject to change without notice. We will match or beat any competitor's price provided it is not below our cost.





# FOR YOUR APPLE\* \$299<sup>95</sup>

## IDC CONNECTORS

DESCRIPTION	SOLDER HEADER	RIGHT ANGLE SOLDER HEADER	WW HEADER	RIGHT ANGLE WW HEADER	RIBBON HEADER SOCKET	RIBBON HEADER	RIBBON EDGE CARD
ORDER BY	IDHxxS	IDHxxSR	IDHxxW	IDHxxWR	IDSxx	IDMxx	IDExx
CONTACTS 10	1.20	1.20	2.60	2.60	1.88	—	3.95
20	1.90	1.90	4.15	4.15	2.75	5.50	4.35
26	2.75	2.75	5.35	5.35	3.50	6.25	5.00
34	3.20	3.20	6.25	6.25	4.50	7.00	6.05
40	3.75	3.75	7.35	7.35	5.40	7.50	6.90
50	4.75	4.75	9.20	9.20	6.50	8.50	8.50

**ORDERING INSTRUCTIONS:** Insert the number of contacts in the position marked "xx" of the "order by" part number listed. Example: A 10 pin right angle solder style header would be IDH10SR

## D-SUBMINIATURE

DESCRIPTION	SOLDER		RIGHT ANGLE SOLDER		RIBBON CABLE		HOODS	
	MALE	FEMALE	MALE	FEMALE	MALE	FEMALE	BLACK HOOD-B	GREY HOOD
ORDER BY	DBxxP	DBxxS	DBxxPR	DBxxSR	IDBxxP	IDBxxS	HOOD-B	HOOD
CONTACTS 9	2.08	2.66	4.83	5.04	4.80	5.22	—	2.25
15	2.69	3.63	5.82	6.27	6.57	5.22	—	2.25
25	3.25	3.75	7.44	8.49	8.61	9.42	1.25	1.25
37	4.80	7.11	9.39	10.95	9.30	11.50	—	2.95
50	6.06	9.24	—	—	—	—	—	3.50

For order instructions see "IDC Connectors" above.

## DIP CONNECTORS

DESCRIPTION	AUGAT STYLE TOOLED ST IC SOCKETS	COMPONENT CARRIERS	RIBBON CABLE DIP PLUGS
ORDER BY	AUGATxx-ST	ICCxx	IDPxx
CONTACTS 8		.65	
14		.75	1.45
16	99	.85	
18		1.00	
20		1.25	
22		1.25	
24	1.99	1.35	2.50
28		1.50	
40		2.10	4.15

For order instructions see "IDC Connectors" above.

## BOOKS — BEST SELLERS

### OSBORNE/MC GRAW-HILL

Apple II User's Guide .....	14.95
CRT Controller's Handbook .....	6.99
68000 Assembly Language Programming .....	16.99
CBASIC User Guide .....	15.00

### SYBEX

Your First Computer .....	8.95
The CP/M Handbook .....	14.95
The PASCAL Handbook .....	18.95
Microprocessor Interfacing Techniques .....	17.95



## ORDER TOLL FREE

800-538-5000

800-662-6279

(CALIFORNIA RESIDENTS)

IF YOU CAN FIND A PRICE LOWER ELSEWHERE, LET US KNOW AND WE'LL MEET OR BEAT THEIR PRICE! (SEE TERMS BELOW)

- \* Computer managed inventory—virtually no back orders!
- \* Very competitive prices!
- \* Friendly staff!
- \* Fast service — most orders shipped within 24 hours!

## RIBBON CABLE

CONTACTS	GREY		COLOR CODED	
	1'	10'	1'	10'
10	.50	4.40	.83	7.30
20	.65	5.70	1.25	11.00
26	.75	6.60	1.32	11.60
34	.98	8.60	1.65	14.50
40	1.32	11.60	1.92	16.80
50	1.38	12.10	2.50	22.00

## BEST SELLING OK MACHINE & TOOL PRODUCTS

### ID WRAP

A SMALL PLASTIC LABEL THAT SLIPS OVER A WIRE WRAP SOCKET THAT LABELS THE PIN NUMBERS ON THE WIRE SIDE OF THE SOCKET.

14 PIN	10/1.83
16 PIN	10/1.83
18 PIN	5/1.83
20 PIN	5/1.83
22 PIN	5/1.83
24 PIN	5/1.83
28 PIN	5/1.83
40 PIN	5/1.83

### WRAP/UNWRAP/STRIP TOOL

THIS TOOL WILL WRAP, UNWRAP & STRIP STANDARD 30 GAUGE SOLID WIRE WRAP WIRE. THE MODIFIED VERVE10N WILL WRAP 1½ TURNS OF INSULATION BEFORE IT WRAPS THE SOLID WIRE.

WSU-30	8.09
WSU-30M	9.17

### EXTRACTOR TOOLS

EX-1 14-20 PIN	2.11
EX-2 24-40 PIN	10.75

### WIRE DISPENSER

CUTS & STRIPS TO ANY LENGTH 50 FT. SPPOL. CHOICE OF BLUE, YELLOW, RED OR WHITE.

5.93

TRI-COLOR DISPENSER	9.17
50 FT. EACH, RED, BLUE & WHITE	

ALL MERCHANDISE 100% GUARANTEED! CALL US FOR VOLUME QUOTES

## WIREWRAP PROTOTYPE CARDS

FR-4 Epoxy Glass Laminate with Gold Plated Contact Fingers

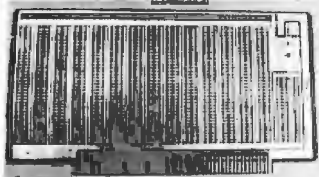

### S-100 BUSS

P100-1	Bare — No Foil Pads .....	15.95
P100-2	Horizontal BUSS .....	22.95
P100-3	Vertical BUSS .....	22.95
P100-4	Single Foil Pads Per Hole ....	23.95
S100-ST	Solder Tail Edge Connector	3.95
S100-WW	Wire Wrap Edge Connector	4.95



### APPLE

P500-1	Bare — No Foil Pads .....	15.95
P500-3	Horizontal BUSS .....	22.95
P500-4	Single Foil Pads Per Hole ....	23.95
50P-ST	50 Pin Edge Connector .....	3.95



### IBM

IBM-PR	BUSS Lines + Pads .....	55.00
--------	-------------------------	-------

### GENERAL PURPOSE

22/44 PIN (.156" SPACING)

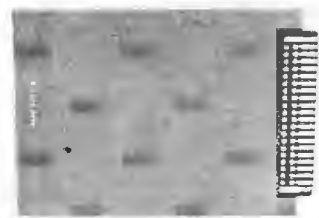

P441-1	Bare — No Foil Pads, 4.5" x 6"	9.95
P442-1	Bare — No Foil Pads, 4.5" x 9"	10.95
P441-3	Vertical BUSS, 4.5" x 6" .....	13.95
P442-3	Vertical BUSS, 4.5" x 9" .....	14.95
P441-4	Single Foil Pads Per Hole, 4.5"x6"	14.95
P442-4	Single Foil Pads Per Hole, 4.5"x9"	15.95
44P-ST	Solder Tail Edge Connector	3.95
44P-WW	Wire Wrap Edge Connector	4.95

36/72 PIN (.1" SPACING)



P721-1	Bare — No Foil Pads, 4.5" x 6"	9.95
P722-1	Bare — No Foil Pads, 4.5" x 9"	10.95
P721-3	Vertical BUSS, 4.5" x 6" .....	13.95
P722-3	Vertical BUSS, 4.5" x 9" .....	14.95
P721-4	Single Foil Pads Per Hole, 4.5"x6"	14.95
P722-4	Single Foil Pads Per Hole, 4.5"x9"	15.95
72P-ST	Solder Tail Edge Connector	6.95
22P-WW	Wire Wrap Edge Connector	7.95

## POWER SUPPLIES



### MODEL 1 \$29<sup>95</sup>

OPEN FRAME STYLE  
MANUFACTURED BY SIGMA  
+5 VOLT 4 AMP



### MODEL 2 \$39<sup>95</sup>

MOUNTED ON PC BOARD  
MANUFACTURED BY CONVER  
+5 VOLT 4 AMP  
+12 VOLT 1 AMP  
-12 VOLT 1 AMP

FOR SHIPPING PLEASE INCLUDE \$4.00 FOR UPS GROUND; \$13.00 FOR UPS BLUE LABEL

## DISKETTES

5 1/4"

ATHANA	SS SD SOFT .....	24.95
MEMOREX	SS SD SOFT .....	26.95
VERBATIM	SS SD SOFT .....	29.95
VERBATIM	10 SECTION HARD ..	29.95

8"

VERBATIM	SS SD SOFT .....	44.95
----------	------------------	-------

## 5 1/4" DISK DRIVES TANDON

TM100-1 (FOR IBM PC)	229.00
SHUGART	
SA 400L	199.95

## CABINET FOR 5 1/4" DISK DRIVE

- ★ COLOR MATCHES APPLE
- ★ FITS SHUGART

**SPECIAL — \$29<sup>95</sup>**

## MICROCOMPUTER HARDWARE HANDBOOK

FROM ELCOMP — \$14.95

Over 800 pages of manufacturers data sheets on most commonly used IC's.

Includes:

- ★ TTL — 74/74LS and 74F
- ★ CMOS
- ★ Voltage Regulators
- ★ Memory — RAM, ROM, EPROM
- ★ CPU's — 6800, 6500, Z80, 8080, 8085, 8086/8
- ★ MPU support & interface — 6800, 6500, Z80, 8200, etc.

## WE NOW STOCK A COMPLETE STOCK OF DISC, ELECTROLYTIC, MONOLITHIC AND TANTALUM CAPACITORS

## RESISTORS

1/4 WATT 5% CARBON FILM ALL  
STANDARD VALUES  
FROM 1 OHM TO 10 MEG OHM

50 PCS. SAME VALUE	.025
100 PCS. SAME VALUE	.02
1000 PCS. SAME VALUE	.015

## JDR MICRODEVICES, INC.

1224 S. Bascom Avenue  
San Jose, CA 95128

800-538-5000 • 800-662-6279 (CA)  
(408) 995-5430 • Telex 171-110



## VISIT OUR RETAIL STORE

HOURS:  
M-F, 9-5; Sat. 11-3

PLEASE USE YOUR CUSTOMER NUMBER WHEN ORDERING

TERMS: For shipping include \$2 for UPS Ground or \$3 for UPS Blue Label Air. Items over 5 pounds require additional shipping charges. Foreign orders include sufficient amount for shipping. There is a \$10 minimum order. Bay Area and Los Angeles Counties add 5% Sales Tax. Other California residents add 6% Sales Tax. We reserve the right to substitute manufacturer. Not responsible for typographical errors. Prices are subject to change without notice. We will match or beat any competitor's price provided it is not below our cost.



# 4116 16K DYNAMIC RAMS 250 NS

# 8/\$11<sup>95</sup> SET



## APPLE\* II COMPUTER USERS DISK DRIVE \$299<sup>95</sup>

- ★ Includes metal cabinet
- ★ Color matches Apple
- ★ 35 Tracks/single side
- ★ Includes cable
- ★ Use with Apple II Controller



## 16K RAM CARD \$69<sup>95</sup>

- ★ Upgrade your 48K Apple II to full 64K of RAM.
- ★ Fully software and hardware compatible with the Apple language card and microsoft Z80 card.
- ★ Eliminates the need for the Applesoft or Integer Basic ROM card when used in conjunction with DOS 3.3.
- ★ Allows you to run Apple Fortran or Pascal with no difficulty.
- ★ Available as bare board, kit, or assembled and tested board.

BARE PC CARD — \$28.00      KIT — \$59.95

## COOLING FAN \$69<sup>95</sup>

- ★ Easy installation.
- ★ No modification of Apple required.
- ★ Color matches Apple.
- ★ Switch on front controls fan, computer and monitor.
- ★ Ultra-quiet, reliable fan.
- ★ Completely eliminates problems caused by overheating.

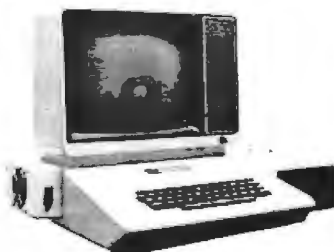

\*Apple is a trademark of APPLE COMPUTER, INC.

## EPSON PRINTERS

MX-80  
MX-80FT  
MX-100

CALL FOR PRICE

WE HAVE APPLE AND TRS-80  
INTERFACE CARDS AND CABLES

## MONITORS

NEC JB-1201 M \$169<sup>00</sup>

ZENITH ZVM-121 \$119<sup>95</sup>

ORDER TOLL FREE

800-538-5000

800-662-6279

(CALIFORNIA RESIDENTS)

IF YOU CAN FIND A PRICE LOWER  
ELSEWHERE, LET US KNOW AND  
WE'LL MEET OR BEAT THEIR PRICE!  
(SEE TERMS BELOW)

- ★ Computer managed inventory—virtually no back orders!
- ★ Very competitive prices!
- ★ Friendly staff!
- ★ Fast service — most orders shipped within 24 hours!

## IBM\* PERSONAL COMPUTER USERS

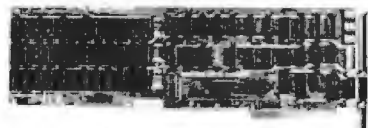

### MEMORY EXPANSION CARD

- ★ 64K - 192K.
- ★ Full single-bit error correction circuitry (ECC) assures reliable memory.
- ★ Fully IBM hardware and software compatible.
- ★ Highest quality PC card.
- ★ Price includes: PC card, card guide, ECC ROM, and manual

BARE PC CARD \$120.00



### DUAL SERIAL CARD WITH GAME ADAPTER

- ★ 2 Asynchronous RS232 Serial Ports.
- ★ Game adapter port.
- ★ Fully IBM compatible.
- ★ Replaces 2 IBM Asynchronous Communication Adapter cards.
- ★ Price includes: PC card, Prom, Mounting Bracket and Manual.

BARE PC CARD \$60.00

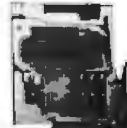

### DELUXE EXTENDER BOARD®

- ★ For designers, experimenters, technicians, and service centers.
- ★ Dip switches enable user to isolate any I/O channel signal.
- ★ Labeled test points for all signals.
- ★ All voltage lines fused and provided with LED indicators.
- ★ Connector extends from IBM PC chassis to allow easy access.

KIT \$80.00

\*IBM is a trademark of INTERNATIONAL BUSINESS MACHINES

® Registered Trademark of Hurricane Labs

# CALIFORNIA DIGITAL

Post Office Box 3097 B • Torrance, California 90503

## DISKETTES

FREE PLASTIC LIBRARY CASE INCLUDED WITH THE PURCHASE OF EVERY BOX OF DISKETTES

**\$24.95**



Please call for California Digital for one of the most complete selections of digital media. Each diskette is certified double density at 40 tracks. To insure excellent media life, our diskettes are manufactured with a reinforced hub-hole lock of surface, a plastic library case is included with every box of diskettes. (MSD-1000-100) Please specify computer or required sectors. Ten boxes \$22.75 One hundred boxes \$21.50

5 1/4" DISKETTES WITH LIBRARY CASE

**\$26.50**

Your Choice  
**SCOTCH MEMOREX VERBATIM**

Soft Sector 10 Sector 16 Sector

SCOTCH	744-0	744-10	744-16	\$26.50
MEMOREX	3401	3403	3405	26.50
VERBATIM	525-01	525-10	NA	26.50
DYSAN	104/1	107/1	NA	39.50

Single Side Double Density

DYSAN	104/1D	107/1D	NA	45.00
-------	--------	--------	----	-------

Double Side Double Density

SCOTCH	745-0	745-10	745-16	42.50
DYSAN	104/2D	107/2D	NA	49.50
DYSAN 96	204/2D	NA	NA	59.50

EIGHT INCH DISKETTES

Single Side Single Density		Single Side Double Density		
SCOTCH	740-0	29.50	SCOTCH 741-0	39.00
MEMOREX	3060	29.50	MEMOREX 3090	35.00
OYSAN	3740/1	39.50	OYSAN 3740/D	57.50
Thirty Two Sector		Double side Double Density		
SCOTCH	740-32	29.50	SCOTCH 743-0	47.50
Special Head Cleaning Kit 5-81		\$4.95		
Plastic Library Cases 3-4-8-17		1.95		
Rotary Flip Top 100's Overlays 2-4		14.95		
Rotary Flip Top 100's Overlays 2		28.95		
			MEMOREX 3114	39.50
			OYSAN 3740/2D	65.00

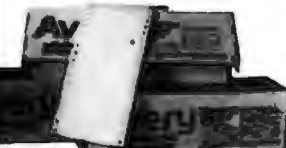

**AVERY LABELS**  
**\$14.95**

Unrated States Post Office approved. 5000 labels per box, 1 1/2 by 1 5/16". AVY-4011 1 box. Also available 2000's (AVY-4011) and removable jigglyback (AVY-4997).

## SWITCHING POWER SUPPLY



**\$49**

Manufactured by Datapower by the Diabolo for diatype data wheel printer. Total weight: 9 V. 3 Amp. 12 V. 1 Amp. -12 V. 1 Amp. Input 117/240V, 1PH-15A 1 line.

## MEMORY

2716 EPROM <b>4.50</b> 450ns	64K DYNAMIC <b>6.95</b> 4164 200ns
16K STATIC <b>7.00</b> 6116 200ns	16K DYNAMIC <b>1.95</b> 4116 200ns



## 2732 EPROM SALE \$7.95

### DYNAMIC MEMORY

4116-150ns 16k	1.31	32-	100-
4116-200ns 16k	1.85	1.85	1.75
4164-150ns 64k Japan 128 refresh	3.75	1.65	1.50
4164-150ns 64k Texas Inst 256 refresh	8.88	6.25	7.00
4164-200ns 64k Japan 128 refresh	7.00	6.05	6.25
4126-200 256k dynamic memory	8.50	7.75	7.50

### STATIC MEMORY

21102-200ns 1k	1.43	1.29	1.19
21102-400ns 1k	1.29	1.15	.99
2112-450ns 2k	3.95	3.50	3.25
214-300ns 4k			
2114-450ns 4k			
4044-750ns 4k			
4044-450ns 4k			
5257-300ns 4k			
6116-P2 100ns 16k 24 pin	7.50	7.25	6.80
6116-P4 200ns 16k 24 pin	7.00	6.75	6.65
6187 2167 100ns 16k 20 pin	9.00	8.50	8.80

### EPROMS

1702-450ns 2k	3.50	2.95	2.75
2708-450ns 8k	4.80	4.15	3.75
2716-450ns 16k	7.95	7.65	7.25
2742-450ns 16k tri-voltage	8.85	5.95	5.45
2716-450ns 16k	8.00	8.00	7.80
2732-450ns 16k	8.29	8.05	6.25
2532-450ns 16k	10.50	8.60	9.50
2716-450ns 16k	14.95	13.75	12.50
27128-450ns 128k			



**ISO-BAR Noise Filter**  
**\$49.95**

Eight recepts in 1/2" chassis size filter and surge suppressor reduces problems caused by voltage spikes by pliers. In-line and bypass power lines. CSC 9R 2116

## SWITCHES

DIP SWITCHES				FOGGLER			
no.	100*	18*		7101 on/off	1.10	1.00	
1	.88	.78	.88	7103 on/off	1.30	1.19	
2	.99	.83	.79	7107 on/off	1.20	1.19	
3	1.03	.91	.87	7108 on/off	1.30	1.19	
4	1.19	.98	.94	7201 depth mount	1.85	1.65	

## CONNECTORS

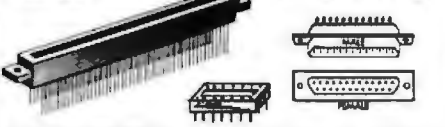

GOLD EDGE CONNECTORS			
5-100 131* connectors	each	30*	
linear socket, 120* pins	\$2.30	\$2.30	
linear wire wrap 131	3.85	7.50	
bullet Hi-Rel. 250*	4.00	4.00	
bullet Hi-Rel. W/F	3.25	4.90	
bullet / Altair-140	6.25	6.50	
.156 Centers (standard)			
22/40 Kern Eyelet	2.90	2.15	
38/72 Digital Group 6/T	5.95	8.20	
38/72 Digital Group W/F	6.80	8.15	
43/88 Motorola 8800 S/T	8.80	8.15	
43/88 Motorola 8800 W/T	7.00	8.85	
INTEGRATED CIRCUIT SOCKETS			
Low Profile Wire Wrap	each 100*	each 100*	
8 pin	\$1.00	\$4.8	8.11
14 pin	1.00	.43	.41
18 pin	.12	.11	.50
18 pin	.15	.13	.48
18 pin	.18	.16	.86
40 pin	.62	.80	1.60
*D Type			
DB9 female	81.90	81.60	81.20
DB9 female	2.23	2.09	1.60
16 pin	1.40	1.35	1.20
16A131* wire	2.38	2.15	2.00
D1118 female	3.25	3.10	2.00
DA board 8/P	1.90	1.33	1.10
DB 23P male	2.50	2.35	2.25
DB 35S female	3.25	3.15	3.03
DB board 2/P	1.30	1.15	1.05
DC 27P male	4.20	4.00	2.70
DC 31S female	4.00	3.75	5.90
DC board 3/P	2.25	2.00	2.25
DD 50P male	3.90	3.70	4.75
DD 50S female	4.40	4.00	4.00
DD 50S hood 2/P	2.60	2.40	2.10
CENTRONICS			
57-50360	7.85	6.75	3.75
RIBBON CABLE CONNECTORS			
17/24 2 disk	4.83	4.41	4.95
20/28 TBS-40	3.85	3.85	4.70
32/40 2 disk	5.90	3.15	4.80



**NEW OLIVETTI 801 \$295**  
Eight Inch Disk Drive

★ OLIVETTI 801	single	*319	309	295
★ OLIVETTI 802/851	double	425	419	410
SHUGART 801/R	single	395	385	375
SHUGART 851/R	double	525	495	475
QUME DATA TRACK 8	double	525	495	475

\* The 8" Olivetti drives are approx. 1/2" wider than the Shugarts.

### Five Inch Disk Drives

OLIVETTI 501/400	single	199	185	175
OLIVETTI 502/451	double	235	225	215

Upon request, all drives are supplied with power connectors and one manual per order.

230 volt 50Hz. 8" add \$50.00 per drive.



**\$995** Eight Inch Subsystem

Two Olivetti 801 disk drives with power supply, 4" exhaust fan complete in dual enclosure with all necessary power cables.

Documentation included. 60 Lbs. CAL-2801  
Signal cable add \$35.00 WCA-550D

Same as above but with:

Shugart 801R	MSD2801	*1195	Olivetti 802	CAL2802	*1250
Shugart 851R	MSD2851	1450	Qume DT8	MSD80T	1450

## SPECIAL

**\$895**

Volume Pricing Upon Request

## Seagate Compatible 7.5 MEGABYTE Winchester Hard Disk Drive

We have priced this so low that the manufacturer has asked not to use their brand name in our advertising. Industry standard Seagate plug compatible. Drive fits into the same space as a 5 1/4" floppy disk drive. CAL-561/2

## CONRAC MONITOR

Nine Inch **\$59**

Requires separate horizontal and vertical sync. Single 12 volt supply. Factory new surplus. Compatible video adapter available (E131) CON-BW9



**TOLL FREE ORDER LINE**  
**(800) 421-5041**  
TECHNICAL & CALIFORNIA  
**(213) 679-9001**

All merchandise sold by California Digital is premium grade. Shipping: First five pounds \$3.00. Each additional \$.50. Foreign orders: 10% shipping. Excess will be refunded. California residents add 6.75 sales tax. COD's discouraged. Open accounts extended to state supported educational institution and companies with a strong D&B Credit. Warehouse: 15608 Inglewood Blvd. Visitors by appointment.







# MICRO SALES

15381 CHEMICAL LANE ★ HUNTINGTON BEACH, CA 92649  
★ (714) 891-2677 ★

## ★ SPECIAL OF THE MONTH ★

ASCII Keyboard On board character PROM  
2716. ASCII inverted data output with doc-  
umentation +5V @ 500 MA



ONLY  
\$39.95

## ★ S-100 SYSTEMS ★

### S-100-12

Complete 12 Slot 3  
board computer with  
Z-80 CPU, 64K Dyn-  
amic Ram, Floppy Disk  
Controller and Disk  
Drives including  
CP/M\*.



With 2 801 Shugart	\$2250.00
With 2 851 Shugart	2500.00
With 2 Qume DT8	2450.00
Less Drives and CP/M*	1350.00
Cabinet Only	250.00

All of the above include Drive Mount Plate Plus AC and DC Cables. Some  
assembly required.

\*CP/M is a Trademark of Digital Research

### S-100-4

Complete 4 slot S-100 computer.  
Perfect for word processing, small  
business accounting, inventory con-  
trol, etc. 1.2 megabytes of storage  
capacity on two 8" floppy drives. (Ex-  
pandable to 2.4 megabytes using  
double sided operation.



- 4MHz Z-80A
- 64K Dynamic Ram
- 2 Serial Ports  
50-19,200 Baud
- 3 Parallel Ports  
(8255)
- Steel Tan and  
Charcoal Case
- Includes CP/M\*

**SPECIAL  
INTRODUCTORY  
OFFER  
\$1595.00**

Complete, ready to attach  
Terminal and Printer  
(Offers ends Sept. 30, 1982)

### XOR Z-80 CPU

\$255.00 A/T

2 Serial/3 Parallel Ports  
On board 2716 PROM  
Z-80 CTC Optional  
Software Baud Rate  
Memory Management A16 - A17  
Serial I/O Cable 2 Ports \$32.00



### XOR DSK

\$275.00 A/T

With WD-1795 Chip Set.  
SS/DD 5" or 8" up to 4 Drives.  
Dual 50 Data Cable - \$35.00



### XOR 64K

★ \$359.00 ★

Dynamic Ram with 4116  
Z-80 Refresh Timing  
I/O Port 40 Bank Select  
4 Layer Construction

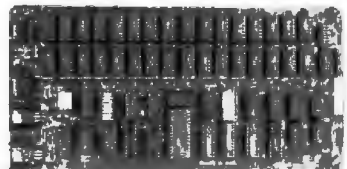

### S-100 MOD KIT by XOR

For test or systems applications.  
Complete S-100 12 Slot Main-  
frame with Disk Drive Power Supply  
for 4 Drives.

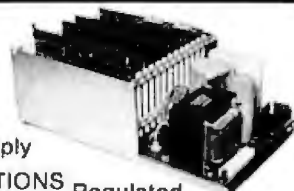

**SPECIFICATIONS** Regulated  
Unregulated  
+8V @ 30 A  
±16V @ 6A  
+5V @ 5A  
+24V @ 3A  
-5V @ 1A

\$199.00 Kit with 6 S-100 Bus Connectors  
\$255.00 Assembled and Tested with 12 Bus Connectors  
\$15.00 AC/DC Drive Cable Set for 2 Drives  
Dimensions 6" x 10" x 18" — Shipping Weight 25 lbs.

## ★ DUAL DRIVE SUBSYSTEMS ★



### HORIZONTAL

Assembled and Tested \$ 235.00  
With 2 801R Shugart 975.00  
With 2 851R Shugart 1225.00

Your Choice of  
**Dual 8" Drive Cabinet**  
with Power Supply, Fan and all Cables  
+5 @ 4A • +24V @ 3A • -5V @ 1A

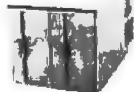

### VERTICAL

★Cabinet Only Special \$ 69.50  
With 2 QUME DT8 1195.00  
With 4 Tandon TM848-1 1995.00

### CABINET With Power Supply



for MINI 5" or WINCHESTER 5"  
+5V @ 4A • +12V @ 3A • -5V @ 1A

Assembled and Tested \$149.50  
Cabinet Only 59.50  
With 2 SA 400 Shugart 595.00  
With 2 SA 450 Shugart 850.00  
With 2 SA 460 Shugart 950.00

### UNIVERSAL POWER SUPPLY



\$69.95

For Big Board, Apple or Aim 65  
+5V @ 3A  
+12V @ .750A  
-12V @ .750A  
-5V @ .500A  
Dimensions: 4" x 4" x 11"

### DISK DRIVE POWER SUPPLY



\$59.95

For 2 8" or 5" Shugart 801R or  
851R, Qume DT-8 with DC  
cables for 8"  
AC cables for 2 drives \$7.50  
Dimensions: 4" x 4" x 11"

### S-100 POWER SUPPLY



\$89.50

+8V @ 30A  
+16V @ 6A  
-16V @ 6A  
PC Board Design  
Dimensions: 5" x 6" x 11"

### S-100 CARD EXTENDER



\$12.50

Kit with all parts,  
fused power lines

### 8" FLOPPY DISKS

SS/DD FOR  
S-100-4, S-100-8  
S-100-12

Fantastic bargain for our  
Special Customers!

\$29.95  
per pkg of 10!

Guaranteed to work 100%  
double density on our  
system!!

# California Computer Systems



- 2810 CPU Only — \$255.00
- 2422 Dsk Cont Only — \$330.00
- 2065C 64K Only — \$320.00
- 2200A Mainframe Only — \$475.00
- CCS Apple Boards Call for prices
- CCS 2200 System Tested and Assembled Only — \$1,625.00

## MICRO SALES

11 EDISON DRIVE ★ NEW LENOX ★ ILLINOIS 60451  
 CALL TOLL FREE: 1-800-435-9357 ★ MONDAY thru SATURDAY  
 (ILLINOIS RESIDENTS CALL: 815-485-4002) ★ 8:00 a.m. to 6:30 p.m.

TERMS: Prepayment — C.O.D. up to \$100.00 — M/C Visa  
 \$5.00 Processing and Handling added to each order PLUS  
 Shipping Charges. Please allow personal check to clear before shipment.  
 15% Restocking Charge for Non-Defective, Returned Merchandise.  
 Prices subject to change without notice.

★ SPECIAL ★ SPECIAL ★ SPECIAL ★

### CCS SYSTEM 2410

#### \*FEATURES\*

- \* DMA Disk Controller
- \* 2-Real Time Clocks
- \* 2-Serial/1-Parallel Port
- \* Hardware Vectored Interrupts
- \* Supports C/PM, M/PM, OASIS
- \*\*\*Comes with C/PM\*\*\*  
 only-\$2,100.00

CONTROLLER BOARD FOR 8" and 5"  
 DRIVES FOR THE Z-89, Z-90, or H-89  
 COMPUTERS....

Comes w/C/PM 2.2 on 8" and 5"  
 media ..... Only \$550.00

### SOFTWARE

ASHTON TATE	
dBASE II .....	\$560.00
DIGITAL RESEARCH	
C BASIC .....	\$118.00
MICRO PRO	
WORDSTAR .....	\$275.00
MAILMERS .....	\$115.00
DATA STAR .....	\$265.00
SUPERSORT I .....	\$190.00
SPELLSTAR .....	\$190.00
MICROSOFT	
BASIC 80 .....	\$290.00
BASIC COMPILER .....	\$320.00
FORTRAN 80 .....	\$400.00
COBOL 80 .....	\$600.00
MACRO 80 .....	\$165.00
SORCIM	
PASCAL/M .....	\$320.00
SUPERCALC .....	\$235.00
SUPERSOFT	
FORTH .....	\$170.00
SSS FORTRAN .....	\$215.00
DISK DOCTOR .....	\$85.00
C COMPILER .....	\$175.00

**WE HAVE COMPLETE LINE OF:** Apple II, TRS-80, IBM, and Heath/Zenith add on drives.

Call For Price!

### FEATURES! TERMINAL

- Feather Touch Capacitance Keyboard
- 60 Key Standard ASCII PLUS • Hex Keypad PLUS • 8 Special Function Keys PLUS • 20 Screen Editing Keys
- SOROC Type Screen Attribute Set
- Half Intensity

### S-100-8

INCLUDING CP/M 2.2\* AND WORDSTAR\*

WITH: 8" SS/DD Drives Only \$2850.00  
 5 1/4" SS/DD Drives Only \$2700.00

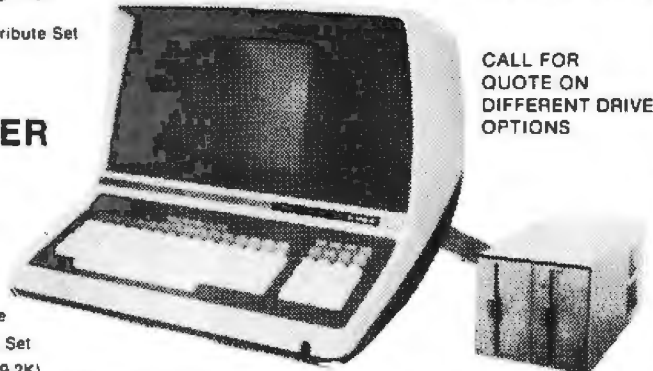

CALL FOR QUOTE ON DIFFERENT DRIVE OPTIONS

### COMPUTER

- 8 Slot S-100
- 64K Dynamic Ram
- 4MHZ Z-80
- Double Density Disk Controller
- Programmable Baud Rate
- Programmable Keyboard Set
- Serial Printer Port (150-19 2K)

WORDSTAR is a TM of Micropro Inc. — CP/M 2.2 is a TM of Digital Research Inc.

### MONITORS

BMC MONITORS—	
W/GREEN SCREEN .....	\$ 95.00
ZENITH VIDEO MONITOR—	
ZVM .....	\$145.00
AMDEK MONITORS—	
AMDEK Color 1 .....	\$399.00
AMDEK Video 300 w/Green Screen .....	\$229.00

### DISK DRIVES

• Shugart 801's .....	\$395.00
• Shugart 851's .....	\$575.00
• Qume DT-8's .....	\$540.00
• SA 400 .....	\$230.00
• SA 450 .....	\$340.00
• SA 410 SS 96 TPI .....	\$375.00
• SA 460 DS 96 TPI .....	\$425.00
• TM 100-1 .....	\$230.00
• TM 100-2 .....	\$340.00
• TM 100-3 .....	\$375.00
• TM 100-4 .....	\$425.00

### TANDON SLIMLINE

• TM 848 - 1 .....	\$480.00
• TM 848 - 2 .....	\$550.00

### PRINTERS

• C-ITOH PROWRITER .....	\$525.00
• C-ITOH F-10 40 CPS .....	\$1,500.00
• C-ITOH Comet II 132 Column Printer 9x7 Dot Matrix .....	\$810.00
• MPI-88G .....	\$600.00
• EPSON MX 80 .....	CALL
• EPSON MX 100 .....	CALL
• Anadex 9501 Graphic Printer .....	\$1,235.00
• OKIDATA 82A .....	\$465.00
• 83A and 84A .....	CALL

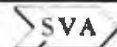

Apple 8" Disk Controller Card	
• ZX4 Dual Density, Single & Double Sided - Auto Boot .....	\$395.00
• Disk 2 + 2 Single Density Single or Dual Sided .....	\$300.00

### TERMINALS

• Adds Regent 20 .....	\$570.00
• Televideo 910 .....	\$575.00
• Televideo 912C .....	\$665.00
• Televideo 925C .....	\$740.00
• Televideo 950 .....	\$950.00
• Ampex Dialog 80 .....	\$895.00
• Zenith Z19 .....	\$745.00



CALL FOR PRICES

\*\*Number of Pins of each I.C. for every Stock purchase

MICROPROCESSOR COMPONENTS

\*Available Kits

INTERMIL

Table with columns: Part No., Price, Part No., Price. Lists various microprocessor components like SN74000, SN74001, etc.

Table with columns: Part No., Price, Part No., Price. Lists static RAM components like 1101, 1102, 1103, etc.

Table with columns: Part No., Price, Part No., Price. Lists dynamic RAM components like 1103, 1104, 1105, etc.

Table with columns: Part No., Price, Part No., Price. Lists various ICs from the INTERMIL section like 74001, 74002, etc.

Table with columns: Part No., Price, Part No., Price. Lists 74LS components like 74LS00, 74LS01, etc.

Table with columns: Part No., Price, Part No., Price. Lists EPROM components like 1702A, 2708, etc.

Table with columns: Part No., Price, Part No., Price. Lists microprocessor chips like Z80, 8080, 8085, etc.

Table with columns: Part No., Price, Part No., Price. Lists 74C-C/MOS components like 74C00, 74C01, etc.

Table with columns: Part No., Price, Part No., Price. Lists 74S/PROMS components like 74S00, 74S01, etc.

Table with columns: Part No., Price, Part No., Price. Lists microprocessor manuals like M-260, M-265, etc.

Table with columns: Part No., Price, Part No., Price. Lists 6800/6800 support devices like 68000, 68001, etc.

Table with columns: Part No., Price, Part No., Price. Lists linear components like LM100, LM101, etc.

Table with columns: Part No., Price, Part No., Price. Lists 8080/8085 support devices like 8080A, 8085A, etc.

Table with columns: Part No., Price, Part No., Price. Lists special function components like 5501, 5502, etc.

Table with columns: Part No., Price, Part No., Price. Lists telephone/keypad chips like 5501, 5502, etc.

BUY NOW... PRICES SLASHED! Shipment in 24 Hours. CONNECTORS. Includes a diagram of a 25 Pin - D Subminiature connector.

Table with columns: Part No., Price, Part No., Price. Lists CA-LINEAR components like CA3010, CA3011, etc.

Table with columns: Part No., Price, Part No., Price. Lists IC sockets like CD-000, CD-001, etc.

Table with columns: Part No., Price, Part No., Price. Lists WIRE WRAP (GOLD) SOCKETS like LEVEL #3, LEVEL #4, etc.

Table with columns: Value, Price, Value, Price. Lists capacitor values and prices like 10pF, 22pF, etc.





# Build a Better Computer

## Save Over \$800.00 on a Powerful Board Set

Full IEEE 696 S-100 signal compliance, 4 MHz Z-80A CPU, extended addressing, 64K of high-speed low-power static RAM, two RS-232 asynchronous serial I/O ports, three parallel I/O ports, software programmable timer, double density disk controller, CP/M 2.2, system monitor/bios/boot firmware in ROM, complete manual set. This special package contains SSM Microcomputer's CB-2, I/O-5, MB64, and Jade Computer's Double-D boards. All necessary firmware and software is included.

The manufacturer's list price on this package is over \$2100.00 ..... **Jade's Package Price only \$1195.00**

### JADE Computer Double-D

Our Best Selling Disk Controller

- IEEE 696 S-100 bus
- Reads and writes single or double density
- Density is software selectable
- CP/M 2.2 compatible in single or double density
- Controls up to four 5 1/4" or 8", single or double-sided drives
- Single or double-sided drives may be mixed in the same system
- On-board Z-80A to assure reliable operation
- EIA level serial printer interface on board, baud rates to 9600 (perfect for despooling operations)
- 2K of RAM on-board
- Uses IBM standard formats
- Designed to meet IEEE signal disciplines
- Works with 8080, 8085, and Z-80 CPU's
- Software programmable head stepping rates
- 4-layer PC board with internal power and ground planes provides very stable, low-noise operation.

The Jade Double-D is the state-of-the-art for double density disk controllers boards. The on-board Z-80A runs simultaneously with and transparent to the S-100 bus. All critical timing is handled on-board, data transfers are fully buffered by sector in the on-board memory, two levels of interrupts are implemented on the Z-80A, and a wait state generator is used to synchronize the on-board processor to the disk transfer rate. The host system need only transfer commands and data through a block of on-board static memory, which can be accessed from the bus. This architecture provides a high degree of timing independence from the host system and extremely fast data transfer rates. Also, since the disk controller program is contained in the on-board RAM, the Double-D's operational characteristics are redefinable at any time during system operation.

The Double-D's speed, versatility, and reliability are unsurpassed by any other S-100 disk controller available on the market today.

The Double-D is completely and professionally documented with both a hardware and software manual. The board is available assembled and tested, as a kit, or as a bare board (the software manual is not included with the bare board). We suggest you order the Double-D as an assembled and tested unit unless you are an experienced kit builder.

IOD-1200B Bare board ..... \$59.95  
 IOD-1200K Kit ..... \$299.95  
 IOD-1200A A & T for 8" ..... \$324.95  
 SFC-58001200E DD boot PROM ..... \$20.00  
 SFC-59002001F CP/M 2.2 for DD ..... \$99.95

### SSM Microcomputer CB-2

Powerful Z-80A S-100 CPU

- Z-80A CPU board
- IEEE 696 S-100 signals
- 2 or 4 MHz switch selectable
- Provision for on-board EPROM or RAM, 2716, 2732, or HM6116
- Dip switch addressing on any 2K or 4K boundary
- One wait state added
- Extended addressing
- Power on/reset firmware jump
- Run/stop and single step switches
- Jumper selectable MWRITE signal
- All lines buffered

The CB-2 Z-80A CPU board operates at 2 or 4 MHz by DIP switch selection and includes two sockets for 2716 or 2732 EPROMs or HM6116 2K RAM chips. Memory sockets can be disabled. Separate run/stop and single step switches allow system evaluation without the use of a front panel.

The CB-2 also features MWRITE for use with or without a front panel, firmware vector jump, and an output port to control 8 extended addressing lines allowing use of more than 65K of memory.

CPU-30300K Kit with manual ..... \$229.95  
 CPU-30300A A & T with manual ..... \$274.95

### SSM Microcomputer I/O-5

2 Serial, 3 Parallel, S-100 I/O

- IEEE 696 S-100 signal discipline
- Two RS-232 asynchronous serial ports
- Three parallel ports
- Independent serial baud rates from 110 to 19,200
- Software-programmable timer for real-time or multi-user applications.

The I/O-5 is the latest in a long line of S-100 interface boards from SSM. The I/O-5 is a two serial, three parallel port interface board. The parallel ports provide a total of 32 bits, supporting various I/O configurations such as a 16-bit software programmable bi-directional interface and two 8-bit interfaces. One 8-bit interface supports direct connection to Centronics compatible printers. The other provides 8-bits of parallel input for such devices as keyboards.

Not only does the I/O-5 give you five (5) interfaces on one board but it also has a software-programmable timer for even greater versatility.

IOI-1015A A & T ..... \$269.95

### SSM Microcomputer MB64

8 or 16 Bit 64K Static RAM Board

- Meets IEEE 696/S-100 standards
- Configured as two 32K byte blocks
- Operates without wait states up to 6 MHz with 8-bit processor, and up to 12 MHz with 16-bit processor
- Up to 8K of 2716 EPROMs can be substituted for RAM
- Provision for battery backup
- Extremely low power consumption
- Less than 35 ma in stand-by mode
- Can be used with Cromemco, North Star, Vector Graphics, Dynabyte, and others
- Can be used to support multi-user applications
- 24-bit extended addressing
- Memory can be disabled in 2K increments
- Supports IO port switching of eight banks of 64K bytes each to extend memory of 8-bit system to 512K bytes
- LEDs indicate which 32K bank is in use.

SSM's MB64 is a fast, reliable, low-cost 64K static memory board for your S-100 computer. It uses state-of-the-art RAM technology to bring you the highest quality available. Its low power RAM generates less heat to give you RAM with increased product life, which in turn gives you better overall system reliability.

MEM-64300A A & T ..... \$499.95

### SSM Microcomputer I/O-8

Eight Serial I/O Ports

- Support for multi-user applications
- IEEE 696 and S-100 compatible
- LED indicators monitor send/receive activity on each port
- Crystal controlled, individually programmable baud rates on each serial port ranging from 110 to 19,200 baud
- Interrupt circuitry provides a variety of interrupt modes
- Timer function provides master interrupt for real time applications

SSM's I/O-8 is state-of-the-art interface technology that gives you eight (8) software programmable serial ports on just one board, minimizing the number of boards required for higher performance and multi-user systems. And, if 8 ports aren't enough, you can use multiple I/O-8's within a single system. This is real Port Power!

IOI-1018A A & T ..... \$469.95

# Printer & Disk Drive Sale

## Printers on Sale

### NEW EPSONS with GRAFTRAX-plus

**MX-80 with GRAFTRAX-plus** 80/132 column, 80 CPS, adjustable pin feed, parallel interface  
**PRM-28080 MX-80 w/GRAFTRAX-plus** ..... \$449.95

**MX-80FT with GRAFTRAX-plus** same as MX-80 with friction feed and pin feed  
**PRM-28082 MX-80FT w/GRAFTRAX-plus** ..... \$539.95

**MX-100 with GRAFTRAX-plus** 132/232 column, correspondence quality, up to 15" paper, friction feed & adjustable pin feed, 18 x 18 dot matrix, 80 CPS.  
**PRM-28100 MX-100 w/GRAFTRAX-plus** ..... \$729.95

**PRA-27084** Serial interface ..... \$54.95  
**PRA-27088** Serial int'l & 2K buffer ..... \$89.95  
**PRA-27081** Apple card ..... \$39.95  
**PRA-27082** Apple cable ..... \$19.95  
**PRA-27086** IEEE 488 card ..... \$59.95  
**PRA-27087** TRS-80 cable ..... \$24.95  
**PRA-27097** GRAFTRAX-plus 80 ..... \$59.95  
**PRA-27197** GRAFTRAX-plus 100 ..... \$64.95  
**PRA-27090** MX-80, FT print head ..... \$44.95  
**PRA-27190** MX-100 print head ..... \$49.95  
**PRA-27063** MX-80 ribbon cart. .... \$13.95  
**PRA-27101** MX-100 ribbon only ..... \$9.95

### BETTER THAN EPSON I - Okidata

**Microline 82A** 80/132 column, 120 CPS, 9 x 9 dot matrix, friction feed, pin feed, adjustable tractor feed (optional), handles 4 part forms up to 9.5" wide, rear & bottom feed, paper tear bar, 100% duty cycle/200,000,000 character print head, bi-directional/logic seeking, both serial & parallel interfaces included, front panel switch & program control of 10 different form lengths, uses inexpensive spool type ribbons, double width & condensed characters, true lower case descenders & graphics  
**PRM-43082** Friction & pin feed ..... \$479.95

**Microline 83A** 132/232 column, 120 CPS, forms up to 15" wide, removable tractor, plus all the features of the 82A.  
**PRM-43083** with FREE tractor ..... \$499.95

**Microline 84** 132/232 column, Hi-speed 200 CPS, full dot graphics built in, plus all the features of the 83A.  
**PRM-43084** Centronics parallel ..... \$1099.95  
**PRM-43085** Serial with 2K buffer ..... \$1149.95

**PRA-27081** Apple card ..... \$39.95  
**PRA-27082** Apple cable ..... \$19.95  
**PRA-27087** TRS-80 cable ..... \$24.95  
**PRA-43081** 2K hi speed serial card ..... \$99.95  
**PRA-43082** Hi-res graphics ROMs 82A ..... \$49.95  
**PRA-43083** Hi-res graphics ROMs 83A ..... \$49.95  
**PRA-43088** Tractor option for 82A ..... \$49.95  
**PRA-43080** Extra ribbons pkg. of 2 ..... \$9.95

### 8023 DOT MATRIX - NEC

100 CPS, proportional spacing, hi-resolution graphics, correspondence quality printing, bi-directional tractor & friction feed.

**NEC-8023A** 8023 parallel ..... \$499.95  
**NEC-8023-01** 8023 ribbon ..... \$11.95

### TP-1 LETTER QUALITY - SCM

12 CPS daisy wheel printer from Smith Corona.  
**PRD-45101** Centronics parallel ..... \$648.95  
**PRD-45102** RS-232C serial ..... \$648.95

### LETTER QUALITY PRINTER - Jade

Uses standard daisy wheels and ribbon cartridges, 16 CPS bi-directional printing, semi-automatic paper loader (single sheet or fan fold), 10/12/15 pitch, up to 16" paper, built-in noise suppression cover.

**PRD-11001** Centronics parallel ..... \$699.95  
**PRD-11002** RS-232C serial model ..... \$969.95  
**PRA-11000** Tractor Option ..... \$169.95

### STARWRITER F-10 - C. Itoh

New 40 CPS daisy wheel printer with full 15" carriage, uses standard Diablo print wheels and ribbons, both parallel and serial interfaces included.  
**PRD-22010** Starwriter F-10 ..... \$1495.95

### PRINTER PALS - F.M.J. Inc.

Desk top printer stand and continuous form paper holder.  
**PRA-99080** for MX-80, MX-80FT, Oki 82A, NEC .. \$29.95  
**PRA-99100** for MX-100, Oki 83A & 84 ..... \$34.95  
**PRA-99700** for letter quality printers ..... \$49.95

## 5 1/4" Disk Drives

**Tandon TM100-1** single-sided double-density 48 TPI  
**MSM-551001** ..... \$219.95 ea 2 for \$199.95 ea

**Shugart SA400L** single-sided double-density 40 track  
**MSM-104000** ..... \$234.95 ea 2 for \$224.95 ea

**Shugart SA455** half-size double-sided 48 TPI  
**MSM-104550** ..... \$349.95 ea 2 for \$329.95 ea

**Shugart SA465** half-size double-sided 96 TPI  
**MSM-104650** ..... \$399.95 ea 2 for \$379.95 ea

**Tandon TM100-2** double-sided double-density 48 TPI  
**MSM-551002** ..... \$294.95 ea 2 for \$269.95 ea

**Shugart SA450** double-sided double-density 35 track  
**MSM-104500** ..... \$349.95 ea 2 for \$329.95 ea

**Tandon TM100-3** single-sided double-density 96 TPI  
**MSM-551003** ..... \$294.95 ea 2 for \$269.95 ea

**Tandon TM100-4** double-sided double-density 96 TPI  
**MSM-551004** ..... \$394.95 ea 2 for \$374.95 ea

**MPI B-51** single-sided double-density 40 track  
**MSM-155100** ..... \$234.95 ea 2 for \$224.95 ea

**MPI B-52** double-sided double-density 40 track  
**MSM-155200** ..... \$344.95 ea 2 for \$334.95 ea

**MPI B-91** single-sided double-density 77 track  
**MSM-155300** ..... \$369.95 ea 2 for \$359.95 ea

**MPI B-92** double-sided double-density 77 track  
**MSM-155400** ..... \$469.95 ea 2 for \$459.95 ea

### 5 1/4" Cabinets with Power Supply

**END-000216** Single cab w/power supply ..... \$69.95  
**END-000226** Dual cab w/power supply ..... \$94.95

## 8" Disk Drives

**Shugart SA810** half-size single-sided double-density  
**MSF-108100** ..... \$424.95 ea 2 for \$394.95 ea

**Shugart SA860** half-size double-sided double-density  
**MSF-108600** ..... \$574.95 ea 2 for \$549.95 ea

**Shugart SA801R** single-sided double-density  
**MSF-10801R** ..... \$394.95 ea 2 for \$389.95 ea

**Shugart SA851R** double-sided double-density  
**MSF-10851R** ..... \$554.95 ea 2 for \$529.95 ea

**Tandon TM848-1** single-sided double-den thin-line  
**MSF-558481** ..... \$379.95 ea 2 for \$369.95 ea

**Tandon TM848-2** double-sided double-den thin-line  
**MSF-558482** ..... \$494.95 ea 2 for \$464.95 ea

**Gume DT-8** double-sided double-density  
**MSF-750080** ..... \$524.95 ea 2 for \$498.95 ea

**Mitsubishi M2894-63** double-sided double-density  
**MSF-289463** ..... \$494.95 ea 2 for \$474.95 ea

**Siemens FDD 100-8** single-sided double-density  
**MSF-201120** ..... \$384.95 ea 2 for \$349.95 ea

## Dual Disk Sub-Systems

### Disk Sub-Systems - Jade

Handsome metal cabinet with proportionally balanced air flow system, rugged dual drive power supply, power cable kit, power switch, line cord, fuse holder, cooling fan, neoprene rubber feet, all necessary hardware to mount 2-8" disk drives, power supply, and fan, does not include signal cable.

**Dual 8" Sub-Assembly Cabinet**  
**END-000420** Bare cabinet ..... \$59.95  
**END-000421** Cabinet kit ..... \$225.00  
**END-000431** A & T ..... \$359.95

**8" Sub-Systems - Single Sided, Double Density**  
**END-000422** Kit w/2 FD100-8Ds ..... \$975.00  
**END-000424** A & T w/2 FD100-8Ds ..... \$1175.00  
**END-000433** Kit w/2 SA-801Rs ..... \$999.95  
**END-000434** A & T w/2 SA-801Rs ..... \$1195.00

**8" Sub-Systems - Double Sided, Double Density**  
**END-000426** Kit w/2 DT-8s ..... \$1224.95  
**END-000427** A & T w/2 DT-8s ..... \$1424.95  
**END-000436** Kit w/2 SA-851Rs ..... \$1274.95  
**END-000437** A & T w/2 SA-851Rs ..... \$1474.95

Prices may be slightly higher at our retail locations. Please contact the store in your area for exact pricing.

## Hard Disk Drives

### 12 MEGABYTE SUB-SYSTEM - DayStar

12 Megabyte Winchester sub-system for most CP/M based microcomputers including Apple II, S-100, IBM PC, NEC, Xerox, TRS-80 II, Heath H-89, and others. Sub-system includes interface, controller, cabinet, power supply, CP/M software patch, & cables - ready to just plug in and run. A 1 Megabyte back-up drive is also available.

**MSH-531010** S-100 sub-system ..... \$2095.00  
**MSH-531020** Apple II sub-system ..... \$2095.00  
**MSH-531030** NEC sub-system ..... \$2095.00  
**MSH-531040** Xerox sub-system ..... \$2095.00  
**MSH-531050** TRS-80 II sub-system ..... \$2095.00  
**MSH-531060** IBM PC sub-system ..... \$2095.00  
**MSH-531099** 1 Megabyte back-up ..... \$699.95

### 12 MEGABYTE WINCHESTER - Tandon

5 1/4" hard disk drive for hi-speed mass storage.  
**MSH-550603** Bare 5 1/4" drive ..... \$1094.95

## Jade Bus Probe

### THE BUS PROBE - Jade

Inexpensive S-100 Diagnostic Analyzer

So your computer is down. And you don't have an oscilloscope. And you don't have a front panel... You're not alone - most computers have their occasional bad days. But without diagnostic equipment such as an oscilloscope (expensive!) or a front panel (expensive!), it can be very difficult to pinpoint the problem. Even if you have an extender board with a superfast probe, you can't see more than one signal at a time. You're stuck, right?

Not anymore. Jade is proud to offer our cost-effective solution to the problems mentioned above: **THE BUS PROBE.**

Whether you're a hobbyist with a cantankerous kluge or a field technician with an anxious computer owner breathing down your neck, you'll find **THE BUS PROBE** speeds your repair time remarkably. Just plug in **THE BUS PROBE** and you'll be able to see all the IEEE S-100 signals in action. **THE BUS PROBE** allows you to see inputs, outputs, memory reads and writes, instruction fetches, DMA channels, vectored interrupts, 8 or 16 bit wide data transfers, plus the three bus supply voltages.

An on-board pulse generator can provide repetitive resets, interrupts, or wait states, for trouble shooting.

**TSX-200B** Bare board ..... \$59.95  
**TSX-200K** Kit ..... \$119.95  
**TSX-200A** A&T ..... \$149.95

## Software

### PLANNER CALC - Target Software

Spread sheet (what if ?) program designed with the user in mind, user oriented (simple english) commands allow you to quickly master this powerful software package, supplied on disk for most CP/M based systems.

**SFA-12251052M** Apple II 5 1/4" CP/M ..... \$49.95  
**SFC-12251050F** SS SD 8" CP/M ..... \$49.95  
**SFC-12251053F** Xerox 8" CP/M ..... \$49.95  
**SFC-12251053M** Xerox 5 1/4" CP/M ..... \$49.95  
**SFX-12251051M** NEC 5 1/4" CP/M ..... \$49.95

## Pac Man

### PAC MAN - Atari

Atari's best selling game for your 800 or 400 computer.  
**SFI-31254022E** Pac Man cartridge ..... \$37.95

## Place Orders Toll Free

Continental U.S. Inside California  
**800-421-5500 800-262-1710**

For Technical Inquires or Customer Service call:  
**213-973-7707**

## JADE Computer Products

4901 W. Rosecrans, Hawthorne, Ca 90250

TERMS of SALE: Cash, checks, credit cards, or Purchase Orders from qualified firms and institutions. Minimum Order \$15.00. California residents add 6% tax. Minimum shipping & handling charge \$3.00. Pricing & availability subject to change

# Disk Drive for Apple \$319.95

## Diskettes

### PREMIUM DISKETTES - Jade

We proudly put our name on these high quality diskettes -

5 1/4" Diskettes, Box of Ten	
MMD-5110103 SS, SD, 01S	\$29.00
MMD-5111003 SS, SD, 10S	\$29.00
MMD-5111603 SS, SD, 16S	\$29.00
MMD-5120103 SS, DD, 01S	\$31.00
MMD-5121003 SS, DD, 010	\$31.00
MMD-5121603 SS, DD, 16S	\$31.00

8" Diskettes, Box of Ten	
MMD-8110103 SS, SD, 01S	\$31.00
MMD-8120103 SS, DD, 01S	\$39.00
MMD-8220103 DS, DD, 01S	\$48.00

### BARGAIN DISKETTES

MMD-5110105 5 1/4" SS, DD, 01S	\$19.95
MMD-5220105 5 1/4" DS, DD, 01S	\$32.95
MMD-8110105 8" SS, SD, 01S	\$24.95
MMD-8120105 8" SS, DD, 01S	\$32.95
MMD-8220105 8" SS, DD, 01S	\$35.95

## Video Monitors

### HI-RES 12" GREEN - Zenith

15 MHz bandwidth 700 lines/inch, P31 green phosphor, switchable 40 or 80 columns, small, light-weight & portable

VDM-201201 List price \$189.95	\$129.95
--------------------------------	----------

### 12" GREEN SCREEN - NEC

20 MHz bandwidth, P31 phosphor ultra-high resolution video monitor with audio.

VDM-561200 List price \$289.95	\$199.95
--------------------------------	----------

### 12" COLOR MONITOR - NEC

High resolution color monitor with audio.

VDC-651212 Color monitor	\$369.95
NEC-1202D RGB color monitor	\$999.95

### 13" COLOR MONITORS - BMC

18 MHz RGB & composite video color monitors

VDC-421320 13" RGB Color	\$329.95
VDC-421310 13" Composite video	\$299.95
VDX-420090 RGB card for Apple	\$149.95

### COLOR MONITORS - Amdtek

Reasonably priced color video monitors.

VDC-80130 13" Color I	\$379.95
VDC-801320 13" Color II	\$894.95
IOV-2300A DVM board for Apple	\$199.95

### AMBER or GREEN MONITORS - Jade

High resolution 18 MHz compact video monitors

VDM-751210 12" Amber phosphor	\$149.95
VDM-751220 12" Green phosphor	\$139.95
VDM-750910 9" Amber phosphor	\$149.95
VDM-750920 9" Green phosphor	\$139.95

## Modems

### SIGNALMAN - Anchor

Direct-connect automatic answer/original selection, 300 Baud full duplex, Bell 103, includes RS-232 cable

IOM-5600A Signalman	\$98.50
---------------------	---------

### SMARTMODEM - Hayes

Sophisticated direct-connect auto-answer/auto-dial modem, touch-tone or pulse dialing, RS-232C interface, programmable

IOM-5400A Smartmodem	\$224.95
IOK-1500A Hayes Chronograph	\$218.95
IOM-2010A Micromodem II	\$328.95
IOM-1100A Micromodem 100	\$368.95

## EPROM Erasers

### ULTRA-VIOLET EPROM ERASERS

Inexpensive erasers for industry or home

XME-3100A Spectronics w/o timer	\$69.50
XME-3101A Spectronics w/ timer	\$84.50
XME-3200A Economy model	\$39.95

## Single User System

### THREE BOARD SET - SD Systems

4 MHz Z-80A CPU, 64K RAM (optional 256K), serial I/O port, parallel I/O port, double density disk controller, CP/M 2.2 & manual set, system monitor, control & diagnostic software. Includes SBC-200, 64K ExpandoRAM II, Versafloppy II, & CP/M 2.2 - all boards are assembled & tested

Board set with 64K of RAM \$1095.00

Board set with 256K of RAM \$1295.00

## Apple II Accessories

### APPLE DISK DRIVE - Fourth Dimension

Totally Apple compatible, 143,360 bytes per drive on DOS 3.3, half-track capability - reads all Apple software, plugs right in to Apple controller as second drive, DOS 3.3, 3.2.1, Pascal, & CP/M compatible.

MSM-123200 Add-on Apple Drive \$319.95

MSM-123100 Controller for above \$89.95

### 16K RAM CARD - for Apple II

Expand your Apple II to 64K, use as language card, full 1 year warranty. Why spend \$175.00?

MEX-16700A Save over \$100.00 \$69.95

### Z-80 CPU CARD - for Apple II

Two computers in one, Z-80 & 6502, more than doubles the power and potential of your Apple, includes Z-80 CPU card CP/M and complete manual set.

CPX-62800A A & T with software \$249.95

### APPLE-CAT - Novation

Software selectable 1200 or 300 baud, direct connect, auto-answer/auto-dial, auxiliary 3-wire RS232C serial port for printer

IOM-5232A Save \$50.00!! \$325.95

### 8" DISK CONTROLLER - Vista

New from Vista Computer, single or double sided, single or double density, compatible with DOS 3.2/3.3, Pascal, & CP/M 2.2, Shugart & Qume compatible

IOD-2700A A & T \$499.95

### 2 MEGABYTES for Apple II

Complete package includes Two 8" double-density disk drives, Vista double-density 8" disk controller, cabinet, power supply, & cables. DOS 3.2/3.3, CP/M 2.2, & Pascal compatible.

1 MegaByte Package Kit \$1495.00

1 MegaByte Package A & T \$1695.00

2 MegaByte Package Kit \$1795.00

2 MegaByte Package A & T \$1995.95

### VISION 80 - Vista Computer

80 column x 24 line video card for Apple II, 128 ASCII characters, upper and lower case, 9 x 10 dot matrix with 3 dot descenders, standard data media terminal control codes, CP/M Pascal & Fortran compatible, 50/60 Hz

IOV-2400A Vista Vision 80 \$299.95

### CPS MULTICARD - Min. Computer

Three cards in one! Real time clock/calendar, serial interface, & parallel interface - all on one card.

IOX-2300A A & T \$179.95

### HI-RES GRAPHICS CARD - Genie

Intelligent printer interface and control card allows full high resolution graphics and screen dumps.

IOP-2405A Genie for Epson \$119.95

IOP-2410A Genie for Okidata \$119.95

IOP-2415A Genie for NEC/C. Itoh \$119.95

## Power Strips

### ISOBAR - GSC

Isolates & protects your valuable equipment from high voltage spikes & AC line noise, inductive isolated ground, 15 amp circuit breaker, U.L. listed

EME-115103 3 socket \$39.50

EME-115105 4 socket \$49.50

EME-115100 8 socket \$54.50

EME-115110 9 socket rackmount \$74.50

## Single Board Computer

### SUPERQUAD - Adv. Micro Digital

Single board, standard size S-100 computer system, 4 MHz Z-80A, single or double density disk controller for 5 1/4" or 8" drives, 64K RAM, extended addressing, up to 4K of EPROM, 2 serial & 2 parallel I/O ports, real time interrupt clock, CP/M compatible

CPC-30800A A & T \$724.95

IOX-4232A Serial I/O adapter \$29.95

### Z-80 STARTER KIT - SD Systems

Complete Z-80 microcomputer with RAM, ROM, I/O, keyboard, display, kludge area, manual, & workbook.

CPS-30100K Kit with workbook \$299.95

CPS-30100A A & T with workbook \$469.95

### AIM-65 - Rockwell International

Complete 6502 microcomputer with alphanumeric display, printer, keyboard, & instruction manual

CPK-50165A 1K AIM-65 \$424.95

CPK-50465A 4K AIM-65 \$474.95

SFK-74600008E 8K Basic ROM \$64.95

SFK-74600004E 4K assembler ROM \$43.95

SFK-74600020E PL 65 ROM \$84.95

SFK-74600010E Forth ROM \$84.95

SFK-74600030E Instant Pascal \$99.95

PSX-030A Power supply \$64.95

ENX-000002 Enclosure \$54.95

### SPECIAL PACKAGE

4K AIM-65, 8K Basic, power supply, & enclosure

Special Package Price \$649.95

## S-100 EPROM Boards

### PROM-100 - SD Systems

2708, 2716, 2732 EPROM programmer with software.

MEM-99520K Kit with software \$189.95

MEM-99520A A & T with software \$249.95

### PB-1 - SSM Microcomputer

2708, 2716 EPROM board with on-board programmer.

MEM-99510K Kit with manual \$154.95

MEM-99510A A & T with manual \$218.95

### EPROM BOARD - Jade

16K or 32K uses 2708 or 2716 EPROMs. 1K boundary.

MEM-16230K Kit w/o EPROMs \$79.95

MEM-16230A A & T w/o EPROMs \$119.95

## S-100 Video Boards

### SPECTRUM COLOR - CompuPro

Full-function color graphics board, up to 8 colors, 256 x 192 graphics, parallel I/O port, 8K RAM

IOV-1870A A & T \$348.95

IOV-1870C CSC \$398.95

### MICROANGELO - Scion

Ultra-high-resolution 512 x 480, 256 color or black & white S-100 video board

IOV-1500A A & T \$999.95

## S-100 MotherBoards

### ISO-BUS - Jade

Silent, simple, and on sale - a better motherboard

6 Slot (5 1/4" x 8 1/2")

MBS-061B Bare board \$10.95

MBS-061K Kit \$39.95

MBS-061A A & T \$59.95

12 Slot (8 1/4" x 8 1/2")

MBS-121B Bare board \$29.95

MBS-121K Kit \$69.95

MBS-121A A & T \$99.95

18 Slot (14 1/2" x 8 1/2")

MBS-181B Bare board \$49.95

MBS-181K Kit \$99.95

MBS-181A A & T \$139.95

### ACTIVE TERMINATOR - CompuPro

A true mother's helper.

TSX-100A A & T \$59.45

Prices may be slightly higher at our retail locations. Please call the store nearest you for local price and availability.

Circle 251 on Inquiry card.

# CompuPro Boards on Sale

## S-100 CPU Boards

### 8086/8087 - CompuPro

16 bit, 8 or 10 MHz 8086 CPU with provisions for 8087 & 80130

CPU-70520A 8 MHz 8086 A & T	\$624.95
CPU-70520C 8 MHz 8086 CSC	\$764.95
CPU-70530A with 8087 A & T	\$1224.95
CPU-70530C with 8087 CSC	\$1455.95

### 8085/8086 - CompuPro

Both 8 & 16 bit CPUs standard 8 bit S-100 bus, up to 8 MHz accesses 16 Megabytes of memory

CPU-20510A 6 MHz A & T	\$398.95
CPU-20510C 6.8 MHz CSC	\$497.95

### CPU-Z - CompuPro

2.4 MHz Z80A CPU, 24 bit addressing.

CPU-30500A 2.4 MHz A & T	\$279.95
CPU-30500C 3.6 MHz CSC	\$374.95

### SBC-200 - SD Systems

4 MHz Z-80A CPU with serial & parallel I/O, 1K RAM, 8K ROM space, monitor PROM included

CPC-30200A A & T	\$399.95
------------------	----------

### THE BIG Z - Jade

2 or 4 MHz switchable Z-80 CPU board with serial I/O, accommodates 270B, 2716, or 2732 EPROM, baud rates from 75 to 9600

CPU-30201B Bare board w/manual	\$35.00
CPU-30201K Kit with manual	\$149.95
CPU-30210A A & T with manual	\$199.95

### CB-2 - SSM Microcomputer

2 or 4 MHz Z-80 CPU board with provision for up to 8K of ROM or 4K of RAM on board, extended addressing, IEEE S-100 front panel compatible.

CPU-30300K Kit with manual	\$229.95
CPU-30300A A & T with manual	\$274.95

### 2810 Z-80 CPU - C.C.S.

2 or 4 MHz Z-80 CPU with serial I/O port & on-board monitor PROM front panel compatible

CPU-30400A A & T with PROM	\$289.95
----------------------------	----------

### 2820 Z-80 DMA CPU - C.C.S.

4 MHz Z-80 CPU board with 2 serial I/O ports & Centronics parallel I/O port, separate data & status ports. DMA daisy chain compatible

CPU-30420A A & T with manual	\$569.95
------------------------------	----------

## S-100 Disk Controllers

### DISK 1 - CompuPro

8" or 5 1/4" DMA disk controller, single or double density, single or double sided, 10 MHz

IOD-1810A A & T	\$449.95
IOD-1810C CSC	\$554.95
SFC-52506580F 8" CP/M 2.2 for Z-80	\$174.95
SFC-52506586F 8" CP/M 2.2 for 8086	\$299.95
SFO-54158000F Oasis single user	\$499.95
SFO-54158002F Oasis multi-user	\$849.95

### VERSAFLOPPY II - SD Systems

Double density disk controller for any combination of 5 1/4" and 8" single or double sided, analog phase-locked loop data separator, vectored interrupts, CP/M 2.2 & Oasis compatible, control/diagnostic software PROM included.

IOD-1160A A & T with PROM	\$359.95
SFC-55009047F CP/M 2.2 with VF II	\$99.95

### 2242 DISK CONTROLLER - C.C.S.

5 1/4" or 8" double density disk controller with on-board boot loader ROM, free CP/M 2.2 & manual set

IOD-1300A A & T with CP/M 2.2	\$399.95
-------------------------------	----------

### DOUBLE D - Jade

High reliability double density disk controller with on-board Z-80A, auxiliary printer port, IEEE S-100, can function in multi-user interrupt driven bus.

IOD-1200B Bare board & hdwr man	\$59.95
IOD-1200K Kit w/hdwr & slwr man	\$299.95
IOD-1200A A & T w/hdwr & slwr man	\$325.95
SFC-59002001F CP/M 2.2 with Double D	\$99.95

## S-100 Memory Boards

### 256K RAMDISK - SD Systems

Expandable RAM III expandable from 64K to 256K using 64K x 1 RAM chips, compatible with CP/M, MP/M, Oasis, Cromemco, & most other Z-80 based systems, functions as ultra-high speed disk drive when used with optional RAMDISK software

MEM-65064A 64K A & T	\$474.95
MEM-65128A 128K A & T	\$574.95
MEM-65192A 192K A & T	\$674.95
MEM-65256A 256K A & T	\$774.95
SFC-55009000F RAMDISK sltwr CP/M 2.2	\$44.95
SFC-55009000F RAMDISK with EXRAM III	\$24.95

### 128K RAM 21 - CompuPro

128K x 8 bit or 64K x 16 bit static RAM board, 12 MHz, 24 bit addressing

MEM-12810A A & T	\$1609.95
MEM-12810C CSC	\$1794.95

### 64K RAM 17 - CompuPro

64K CMOS static RAM board, 10 MHz, low power less than 4 watts, DMA compatible, 24 bit addressing

MEM-64180A 64K A & T	\$549.95
MEM-64180C 64K CSC	\$698.95

### 64K RAM 16 - CompuPro

32K x 16 bit or 64K x 8 bit low power static RAM board, 10 MHz, 24 bit addressing

MEM-32180A RAM 16 A & T	\$598.95
MEM-32180C RAM 16 CSC	\$698.95

### 64K STATIC RAM - SSM

IEEE 696 S-100 standard, up to 6MHz 8 Bit, 12MHz/16 Bit, 24 Bit extended addressing, disable-able in 2K increments

MEM-64300A A & T	\$499.95
------------------	----------

### 64K STATIC RAM - Mem Merchant

64k static S-100 RAM card, 4 to 16K banks up to 8 MHz.

MEM-64400A 64K A & T	\$499.95
----------------------	----------

### 2065 64K RAM - C.C.S.

4 MHz bank port/bank byte selectable, extended addressing, 16K bank selectable, front panel compatible

MEM-64565A 64K A & T	\$349.95
----------------------	----------

### 2066 64K RAM - C.C.S.

64K RAM board with bank and block select switching functions for Cromemco Cromix & Alpha Micro.

MEM-64566A 64K A & T	\$424.95
----------------------	----------

### 64K EXPANDORAM II - SD Systems

Expandable RAM board from 16K to 64K using 4118 RAM chips

MEM-16630A 16K A & T	\$344.95
MEM-32631A 32K A & T	\$364.95
MEM-48632A 48K A & T	\$384.95
MEM-64633A 64K A & T	\$399.95

### MEMORY BANK - Jade

4 MHz S-100 bank selectable expandable to 64K

MEM-99730B Bare board w manual	\$49.95
MEM-99730K Kit with no RAM	\$179.95
MEM-32731K 32K kit	\$199.95
MEM-64733K 64K kit	\$249.95
Assembled & Tested	add \$50.00

### 32K RAM 20 - CompuPro

32K static RAM, up to 10 MHz, disable-able in 4K banks, bank select or 24 bit addressing.

MEM-16180A 16K A & T	\$259.95
MEM-16180C 16K CSC	\$324.95
MEM-24180A 24K A & T	\$324.95
MEM-24180C 24K CSC	\$384.95
MEM-32185A 32K A & T	\$384.95
MEM-32185C 32K CSC	\$449.95

### 16K STATIC RAM - Mem Merchant

4MHz lo-power static RAM board, IEEE S-100, bank selectable, addressable in 4K blocks, disable-able in 1K segments extended addressing.

MEM-16171A 16K A & T	\$149.95
----------------------	----------

## S-100 I/O Boards

### SYSTEM SUPPORT 1 - CompuPro

Real time clock, three 16 bit interval timers, dual interrupt controllers (15 levels), up to 4K EPROM/ROM, RS-232C serial channel, provision for 9511A/9512 main chip.

IOX-1850A SS1 A & T	\$359.95
IOX-1850C SS1 CSC	\$459.95
IOX-1855A with 9511 A & T	\$554.95
IOX-1855C with 9511 CSC	\$654.95
IOX-1860A with 9512 A & T	\$554.95
IOX-1860C with 9512 CSC	\$654.95

### INTERFACER 1 - CompuPro

2 serial I/O ports 50-19.2K baud

IOI-1810A A & T	\$218.95
IOI-1810C CSC	\$288.95

### INTERFACER 2 - CompuPro

3 parallel, 1 serial, & interrupt timer

IOI-1820A A & T	\$218.95
IOI-1820C CSC	\$288.95

### INTERFACER 3 - CompuPro

5 or 8 channel serial I/O board for interrupt driven multi-user systems up to 250K baud.

IOI-1835A 5 port A & T	\$558.95
IOI-1835C 5 port CSC	\$628.95
IOI-1838A 8 port A & T	\$628.95
IOI-1838C 8 port CSC	\$749.95

### INTERFACER 4 - CompuPro

3 serial, 1 parallel, 1 Centronics parallel.

IOI-1840A A & T	\$314.95
IOI-1840C CSC	\$414.95

### MPX - CompuPro

Multi-user I/O multiplexer & interrupt controller with on-board 8085A-2 CPU & 4K or 16K of RAM.

IOI-1875A 4K MPX A & T	\$444.95
IOI-1875C 4K MPX CSC	\$534.95
IOI-1880A 16K MPX A & T	\$584.95
IOI-1880C 16K MPX CSC	\$674.95

### I/O-8 - SSM Microcomputer

Eight software programmable serial I/O ports, 110-19.2K Baud, ideal for multi-user systems

IOI-1018A A & T	\$469.95
-----------------	----------

### I/O-5 - SSM Microcomputer

Two serial & 3 parallel I/O ports, 110-19.2K Baud

IOI-1015A A & T	\$289.95
-----------------	----------

### MPC-4 - SD Systems

Intelligent 4-port serial I/O card, on-board Z-80A, 2K RAM, 4K PROM area, on-board firmware, fully buffered, vectored interrupts, four CTC channels, add to SD Board set for powerful multi-user system

IOI-1504A A & T w/software	\$495.00
----------------------------	----------

### I/O-4 - SSM Microcomputer

2 serial I/O ports plus 2 parallel I/O ports

IOI-1010B Bare board w/manual	\$35.00
IOI-1010K Kit with manual	\$178.95
IOI-1010A A & T with manual	\$249.95

### 2830 6 PORT SERIAL - C.C.S.

Six asynchronous RS-232C serial I/O ports with programmable baud rates.

IOI-1040A A & T with manual	\$529.95
-----------------------------	----------

### 2710 4 PORT SERIAL - C.C.S.

Four RS-232C serial I/O ports with full handshaking.

IOI-1060A A & T with manual	\$318.95
-----------------------------	----------

### 2719 2 SER & 2 PAR - C.C.S.

Two RS-232C serial I/O ports plus two 8 bit parallel I/O ports.

IOI-1080A A & T with manual	\$349.95
-----------------------------	----------

**1**  
ONE

**THERE ARE NO BETTER BOARDS —  
THERE ARE NO BETTER PRICES!**

# CompuPro FROM SYSTEMS PRIORITY ONE ELECTRONICS

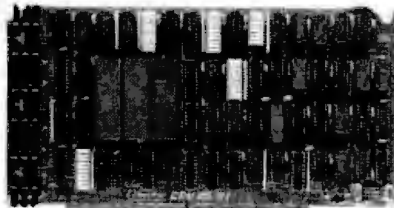

**CPU BOARDS  
CO-PROCESSOR 8086/8087**  
16 bit 8 or 10 MHz 8086 CPU with sockets  
for 8087 and 80130

Part No.	Description	List Price	Our Price
BIGBT106A	A&T 8MHz 8086 only	\$695.00	\$ 495.00
BIGBT106C	CSC 10MHz 8086 only	\$850.00	\$765.00
BIGBT106A07	A&T with 8087 option	\$995.00	\$795.00
BIGBT106C07	CSC with 8087 option*	\$1150.00	\$1065.00

**SAVE \$200.00!!**

**DUAL PROCESSOR 8085-8088**

5 or 8 MHz Provides true 16 Bit Power with a standard  
8 bit S-100 bus

BIGBT1012A	A&T 6MHz	\$425.00	\$325.00
BIGBT1012C	CSC 6/8 MHz	\$525.00	\$425.00

**SAVE \$100.00!!**

TURN PAGE FOR COMPLETE COMPUPRO SYSTEMS

**CPUZ - Z80B CPU NOW 6MHz!**

3/8 MHz Z80B CPU with 24 Bit Addressing.  
FASTEST Z80 CPU AVAILABLE!

BIGBT100A	3/8 MHz A&T	\$295.00	\$225.00
BIGBT100C	3/8 MHz CSC	\$395.00	\$375.00



**DISK CONTROLLERS  
DISK 1 FLOPPY CONTROLLER**

Fast DMA, Soft Sector, Controls 8" or 5 1/4" Single or  
Double Density. OUR BEST!

BIGBT11ACPM	A&T w/CP/M2.2 & BIOS	\$670.00	\$450.00
BIGBT1171C	CSC	\$595.00	\$555.00
BIGBTCPM00*	CP/M 2.2 for Z80/8085 with manuals & BIOS 8" S/D disk	\$795.00	\$175.00
BIGBTCPM05	CP/M for 8088 with manuals & BIOS 8" S/D disk	\$300.00	

**SAVE \$220.00!!**

**DISK 2/SELECTOR CHANNEL  
HARD DISK CONTROLLER**

Fast DMA 2 board set. Controls 4 Shugart 4000 series  
or Fujitsu 2300 type drives. Includes CP/M 2.2\*

BIGBT177A	Assembled & Tested	\$795.00	\$595.00
BIGBT177C	CSC	\$895.00	\$695.00

**SAVE \$200.00!!**

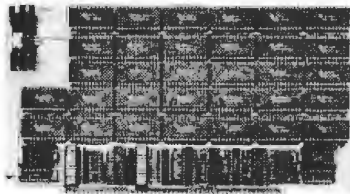

**CMOS RAM SALE!**

**RAM 17 - 64K CMOS STATIC RAM**  
RAM 17, 12 MHz, 2 Wait, DMA Compatible 24 Bit Addressing

Part No.	Description	List Price	Our Price
BIGBT175A04	64K A&T	\$599.00	\$369.00
BIGBT175C04	64K CSC	\$750.00	\$699.00

**SAVE \$236.00!!**

**RAM 16 - 32K x 16 BIT CMOS STATIC RAM**  
8 and/or 16 Bit

816 RAM 16 12 MHz, 32K x 16 or 64K x 8  
IEEE/696 8 or 16 Bit 2 Wait, 24 Bit Addressing

BIGBT180A	64K A&T	\$650.00	\$429.00
BIGBT180C	64K CSC	\$750.00	\$699.00

**SAVE \$221.00!**

**NEW! RAM 21 - 128K STATIC RAM**

816 RAM 21 12MHz, 128K x 8 or 64K x 16  
IEEE/696 8 or 16 Bit 1.2 Amps, 24 Bit Addressing

BIGBT190A	128K A&T	\$1695.00	\$ 995.00
BIGBT190C	128K CSC	\$1895.00	\$1795.00

**SAVE \$700.00!!!**

**M-DRIVE SOLID STATE DISK DRIVE,  
3500% FASTER!**

Not Really, But the Next Best Thing for CompuPro 8085/88  
Users: Call for Detail on M-Drive  
M-Drive requires a 6MHz CPU 8085/88 dual processor, Disk  
1 DMA disk controller and System Support 1 Multifunction  
Board

BIGBTM120KA	128K of A&T memory & M-Drive Software	\$1199.00
BIGBTM120KC	128K of CSC memory & M-Drive Software	\$1399.00
BIGBTM256KA	256K of A&T memory & M-Drive Software	\$2385.00
BIGBTM256KC	256K of CSC memory & M-Drive Software	\$2795.00

**STATIC MEMORY BOARDS**

**RAM 20 - 32K STATIC RAM**  
RAM 20 10 MHz, 4K byte block disable, bank select  
or 24 bit addressing available 8, 16, 24 or 32K

BIGBT184A08	8K A&T	\$210.00	\$180.00
BIGBT184C08	8K CSC	\$280.00	\$260.00
BIGBT184A16	16K A&T	\$285.00	\$260.00
BIGBT184C16	16K CSC	\$355.00	\$325.00
BIGBT184A24	24K A&T	\$355.00	\$325.00
BIGBT184C24	24K CSC	\$425.00	\$385.00
BIGBT184A32	32K A&T	\$425.00	\$295.00
BIGBT184C32	32K CSC	\$495.00	\$450.00



**S-100 MAINFRAME**

110V 60Hz CVT Mainframe uses famous 20 slot  
COMPUPRO Motherboard. (55 lbs.)

BIGBTENC00M	20 Slot Rackmount	\$895.00	\$760.00
BIGBTENC00K	20 Slot Desk Top	\$925.00	\$899.00



**I/O BOARDS**

**SYSTEM SUPPORT 1 MULTIFUNCTION BOARD**

Serial port (software prog. baud), 4K EPROM or RAM  
provision, 15 levels of interrupt, real time clock,  
optional math processor

Part No.	Description	List Price	Our Price
BIGBT102A	Assembled & Tested	\$399.00	\$295.00
BIGBT102C	CSC	\$495.00	\$469.00
BIGBT0231	Math Chip		\$195.00
BIGBT0232	Math Chip		\$195.00
BIGBT02AM1	A&T with 8231 Math Chip		\$490.00
BIGBT02CM1	CSC w/8231 Math Chip		\$635.00
BIGBT02AM2	A&T w/8232 Math Chip		\$490.00
BIGBT02CM2	CSC w/8232 Math Chip		\$635.00

**SAVE \$100.00!!**

**MPX CHANNEL BOARD**

I/O Multiplexer, using 8085A-2 CPU on board with 4K RAM

BIGBT100AA	Assembled & Tested	\$495.00	\$395.00
BIGBT100CA	CSC	\$595.00	\$475.00

With 16K RAM

BIGBT100A15	Assembled & Tested	\$649.00	\$525.00
BIGBT100C15	CSC	\$749.00	\$649.00

**INTERFACER 1**

Two Serial I/O

BIGBT133A	Assembled & Tested	\$249.00	\$199.95
BIGBT133C	CSC	\$324.00	\$298.00

**INTERFACER 2**

Three parallel, one serial I/O board

BIGBT150A	Assembled & Tested	\$249.00	\$199.95
BIGBT150C	CSC	\$324.00	\$299.00

**INTERFACER 3**

Eight channel multi-use serial I/O board

BIGBT1748A	Assembled & Tested	\$699.00	\$469.00
BIGBT1748C	CSC 200 hr. 8 Port	\$849.00	\$750.00
BIGBT1745A	Assembled & Tested	\$599.00	\$399.00
BIGBT1745C	CSC 200hr. 5 port	\$699.00	\$629.00

**INTERFACER 4**

Three Serial, 1 Parallel, 1 Centronics Parallel

BIGBT107A	Assembled & Tested	\$350.00	\$315.00
BIGBT107C	CSC	\$450.00	\$415.00

**SPECTRUM COLOR GRAPHICS**

Color Graphics board with Parallel I/O

BIGBT144A	Assembled & Tested	\$399.00	\$249.00
BIGBT144C	CSC	\$449.00	\$339.00
BIGBT2D	Sublogic Universal Graphics Interpreter Software		\$35.00

**SAVE \$150.00!**

**S-100 MOTHERBOARDS**

Active termination, 8-12-20 Slot

BIGBT153A	A&T 6 slot, 2 lbs.	\$140.00	\$125.00
BIGBT153C	CSC 6 slot, 2 lbs.	\$190.00	\$175.00
BIGBT154A	A&T 12 slot, 3 lbs.	\$175.00	\$155.00
BIGBT154C	CSC 12 slot, 3 lbs.	\$240.00	\$229.00
BIGBT155A	A&T 20 slot, 4 lbs.	\$265.00	\$235.00
BIGBT155C	CSC 20 slot, 4 lbs.	\$340.00	\$319.00

**SAVE!**

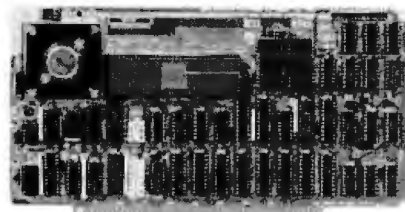

### CPU BOARDS

#### CPU/68000 - 8MHz 68000 CPU

16 bit 68000 CPU with on board ROM containing MACSUBG Monitor or Motorola 68541 Memory Management Unit (MMU).

Part No.	Description	List Price	Our Price
BIDULC700000	A&T with Monitor	\$1195.00	\$1075.00
BIDULC700000	A&T with MMU	\$1495.00	\$1395.00

### MEMORY BOARDS

#### DMEM256K-256K DYNAMIC MEMORY MODULE

256Kb with byte parity error detection for 8 or 16 bit computers

BIDULMEM256	256K A&T	\$1495.00	\$1395.00
-------------	----------	-----------	-----------

#### CMEM NONVOLATILE CMOS MEMORY

Nonvolatile CMOS memory with 3-10 year battery backup on board.

BIDULCMEM8	8K A&T	\$699.00	\$620.00
BIDULCMEM16	16K A&T	\$795.00	\$725.00
BIDULCMEM32	32K A&T	\$995.00	\$940.00

### 2716/2732 EPROM BOARD

#### WITH 16 BIT DATA PATH

Designed to hold 32Kb of 2716 type or 64Kb of 2732 type EPROMs, or ROMs for read only use with 16 bit CPU systems.

BIDULEPROM32	2716 EPROM Board A&T	\$295.00	\$280.00
BIDULEPROM64	2732 EPROM Board A&T	\$295.00	\$280.00

### REAL TIME & DATA ACQUISITION

#### SI04/DMA INTELLIGENT CONTROLLER

4 port RS232 interface with DMA transfers for output. 256b FIFO input buffer. On board 8085A-2 processor, 16 program selectable baud rates and occupies only 16 I/O addresses. Ideal for DUAL UNIX\* or other multi-user systems.

BIDULSI04DMA	Assembled & Tested	\$695.00	\$650.00
--------------	--------------------	----------	----------

#### AIM 12-12 BIT A/D CONVERTER

A/D input module with 12 bit accuracy, 32 input channels and optional instrumentation amplifier

BIDULAIM12	A&T with Instrumentation Amp.	\$745.00	
BIDULAIM12B	A&T without Instrumentation Amp.	\$680.00	

#### AOM 12-12 BIT D/A CONVERTER

D/A output module, 4 channels, 12 bit accuracy. Optional VIC420 industrial output module (4-20Ma), 4 channels, used in conjunction with AOM12

BIDULAOM12	Assembled & Tested	\$875.00	\$840.00
BIDULVIC420	Assembled & Tested	\$675.00	\$640.00

#### CLK24-NONVOLATILE CLOCK/CALENDAR

Day, date, hours, minutes, seconds, and 3-5 year battery backup on board. Read or write directly from I/O port. Jumperable for 64Hz UNIX\* or real time applications.

BIDULCLK24C	A&T w/64Hz Interrupt	\$300.00	\$285.00
-------------	----------------------	----------	----------

### SALE SOFTWARE

#### DIGITAL RESEARCH

BIDIRCMP	CP/M® 2.2 Control Program/Microcomputers	\$150.00	
BIDIRMAC	MAC® Macro Assembler	\$ 80.00	
BIDIRMAC	RMAC® Relocating MAC	\$200.00	
BIDIRSID	SID® Symbolic Instruction Debugger	\$100.00	
BIDIITEX	TEX® Text Formatter	\$100.00	
BIDIRDES	DESPOOL® Background Print Utility	\$ 30.00	
BIDIRC80	CBASIC® Programming Language	\$150.00	
BIDIRC80	CBASIC-86® Programming Language	\$325.00	

#### \*Trademark of Digital Research

#### MICROPRO INTERNATIONAL

BIDMSWSTH	WordStar Version® 3.0	\$249.00	
BIDMSLMRG	Mail Merge®	\$100.00	
BIDMSSPSTH	Spell Star®	\$150.00	
BIDMSCALSTH	Calc Star®	\$200.00	
BIDMSDATSTH	Data Star®	\$200.00	
BIDMSSUPSTH	Supersort®	\$150.00	

\*Trademark of Micropro International

#### SORCIM

BISORSCAL	SUPERCAL® a Superior Electronic Worksheet	\$229.00	
BISORACTI	ACT I® 8080/Z80 Assembler	\$175.00	
BISORACTII	ACT II® 8086/8088 Assembler	\$175.00	
BISORTRNS	TRANS® 8086/8088 Translator	\$125.00	
BISORPMB0	PASCAL/M® REL4 8080/8085/Z-80	\$395.00	
BISORPMB6	PASCAL/M® 8086	\$495.00	

\*Trademark of Sorcim

#### MICROSOFT

BIDMSBAS80	BASIC-80® Version 5.X Extended Disk Basic	\$300.00	
BIDMCPBASC	BASIC® Compiler Version 5.X	\$395.00	
BIDMSBFT	FORTRAN-80®	\$500.00	

\*Trademark of Microsoft/Consumer Products

## MicroFrame®



110V 60Hz CVT Mainframes, the best money can buy  
12 Slot ±8V 17±16V ±2A  
22 Slot±8V @ 30A±16V ±4A

PART NO.	DESCRIPTION	LIST PRICE	SALE
BITEIMCS112	12 Slot Desk	\$755.00	\$620.00
BITEIMCS122	22 Slot Desk	\$910.00	\$745.00
BITEIRM12	12 Slot Rackmount	\$800.00	\$655.00
BITEIRM22	22 Slot Rackmount	\$965.00	\$790.00

Shipping Weight: On 12 Slot Mainframes: 45 lbs  
On 22 Slot Mainframes: 55 lbs

### S-100 MAINFRAME WITH 12 SLOT MOTHERBOARD AND CUTOFFS FOR 3 - 5 1/4" FLOPPY DISK DRIVES

+8V ± 17A ±16V @ 2A +12V ± 1.2A Internal Power Cable

BITEIF12	12 Slot desk	\$745.00	\$605.00
BITEIRF12	12 Slot Rackmount	\$855.00	\$695.00

Shipping Weight: On 12 Slot Desk: 40 lbs.  
On 12 Slot Rackmount: 45 lbs.

### DUAL 8" DISK DRIVE CHASSIS

For two Shugart 801R or two Qume DT-8 size drives with internal power cables provided  
+24V ± 1.5A +5V ± 1.0A - 5V @ 25A

BITEIDFB0	Desk Top	\$565.00	\$480.00
BITEIRFB0	Rackmount	\$725.00	\$650.00

Shipping Weight: On Desk Top: 40 lbs.  
On Rackmount: 45 lbs.

PRIORITY ONE ELECTRONICS is a master distributor for TEL Dealers & OEM's call for quantity pricing.



### SMARTMODEM

• Auto Answer, Auto Dial, Full or Half-Duplex, Loop Back • Serial binary, and asynchronous data formats with 7 or 8 data bits, 1 or 2 stop bits, odd, even or no parity • 0-300 baud • RS232C interface • Z8 Microprocessor with 2Kb control program • 40 character command buffer • Size 1 1/2" x 5 1/2" x 9 1/2"

BIDCH200P	Smartmodem (Sh. Wt. 6 lbs.)	\$279.00	\$225.00
BIDCH400P	Smartmodem 1200 baud (6 lbs.)	\$699.00	\$649.00
BIDCH300P	Chronograph (Sh. Wt. 3 lbs.)	\$249.00	\$205.00
BIDCH100P	Microprogram 100 (Sh. Wt. 4 lbs.)	\$399.00	\$325.00
BIDCH29010	CP/M® 8" Terminal Program for above	\$ 25.00	
BIDCH900P	Microprogram II	\$379.00	\$299.00
BIDCH24010	Datcom (PASCAL patch) for above	\$ 50.00	



### WORLD'S BEST SELLING TERMINAL

Extra Memory Pages FREE!!

BIDPBT19252P	\$749.00	
*TeleVideo 925 w/free 2nd page memory kit, a \$95.00 value		
BIDPBT19504P	\$849.00	
*TeleVideo 950 w/free 2nd, 3rd & 4th page memory kit, \$265.00 value		
BITLV1010	\$809.00	
With emulators & foreign languages		
BITLV1010LK	\$909.00	
Black mode version of above		
(Shipping Weight 37 lbs.)		



### BEST BUYS!

SEND \$1.00 TODAY FOR THE NEW, FULL COLOR SPRING 1982 ENGINEERING SELECTION GUIDE!



## PRIORITY ONE ELECTRONICS

9161 DEERING AVE • CHATSWORTH, CA 91311

ORDER TOLL FREE (800) 423-5922 CA, AK, HI CALL (213) 709-5464

Terms: U.S. VISA, MC, BAC, Check, Money Order. U.S. Funds Only. CA residents add 6 1/2% Sales Tax. MINIMUM PREPAID ORDER \$15.00. Include MINIMUM SHIPPING & HANDLING of \$3.00 for the first 3 lbs plus 40¢ for each additional pound. Orders over 50 lbs. sent freight collect. Just in case, please include your phone number. Prices subject to change without notice. We will do our best to maintain prices through September, 1982. Credit Card orders will be charged appropriate freight. If you haven't received your Spring '82 Engineering Selection Guide, send \$1.00 for your copy today! Sale prices are for prepaid orders only.

## MORROW DESIGNS



### SALE! S-100 5-26 MB HARD DISK SUBSYSTEMS 5 - 16 Mb DMA SUBSYSTEMS

Each subsystem includes DMA Hard Disk Controller, Seagate ST506 5 Mb ST412 10 Mb, or CMI 16Mb 5 1/4" Hard Disk, Cabinet, power supply, CP/M™ 2.2 and Microsoft BASIC.

BIMOSDMM*	Software supplied on 8" IBM 3740 disk with blank I/O and INSTALL program		
BIMOSDMM*28	Software configured for Morrow DJ/2B controller and Mult I/O as console		
BIMOSDMM*DMA	Software configured for Morrow DJ/DMA controller and Mult I/O as console		
BIMOSDMM*NS	Software supplied on 5 1/4" 10 sector North Star disk with blank I/O and INSTALL Program		

Replace \* in above part numbers with B for 5Mb Subsystems 10 for 10Mb Subsystems, or 16 for 16Mb Subsystems  
DISCUSM5 - 5Mb Subsystems \$2195.00 \$1495.00  
DISCUSM10 - 10Mb Subsystems \$2795.00 \$2375.00  
DISCUSM16 - 16Mb Subsystems \$3495.00 \$2975.00  
(order by part numbers listed above)

### DISCUS HDC 20-26 Mb SUBSYSTEMS

Each subsystem includes HDCA3 I/O mapped controller, Shugart SA400B 14" 26Mb or Fujitsu 230B 8" 20Mb Hard Disk, cabinet, power supply, CP/M™ 2.2 & Microsoft BASIC (Shipping Weights: M20 40 lbs., M26 3 boxes 6, 28, & 45 lbs.)  
BIMOSHDC20 Discus M20 A&T \$4495.00 \$3394.00  
BIMOSHDC26 Discus M26 A&T \$4495.00 \$3394.00

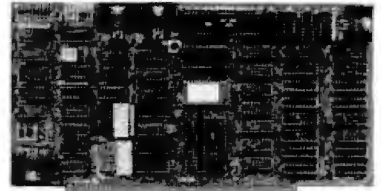

### VIDEO AND I/O

#### VB 3 - HIGH RESOLUTION VIDEO

80 x 25 or 50 character video display Memory Mapped, Parallel Keyboard port

BISSMVB3AZ480	x 24 A&T	\$499.00	\$419.00
BISSMVB3UP	80 x 50 Line Upgrade		\$ 39.00

#### I/O 4

Two serial I/O, two parallel I/O  
Assembled & Tested \$290.00 \$260.00

#### NEW!

#### I/O 5

2 Serial, 3 parallel including 1 Centronics  
Assembled & Tested \$329.00 \$290.00

#### NEW!

#### I/O 8

8 Port Serial I/O with Timer  
Assembled & Tested \$550.00 \$469.00

### CPU, RAM & PROM

#### CB2 Z80 CPU

2/4 MHz w/ accept 2716, or 2732, or RAM  
Assembled & Tested \$299.00 \$280.00  
SSM Z80M SSM Z80 Monitor \$ 89.00

#### MB10A 16/8K 8/16 BIT STATIC RAM

16K byte /8K word, 24 bit extended addressing, "M write," Phantom disable, addressable in 4K blocks  
Assembled & Tested \$299.00 \$275.00

#### MB8A 1K/16K EPROM BOARD

1K/16K 2708 EPROM board, disable in 1K increments  
Assembled & Tested \$179.00 \$150.00

#### PBI PROM PROGRAMMER

Programs 2708 or 2716's, operates as a 4K/8K EPROM BOARD AS WELL  
Assembled & Tested \$265.00 \$210.00



## COMPLETE **CompuPro** SYSTEMS

**FREE SUPERCALC-86! FREE dBASE III!  
AND A TELEVIDEO TERMINAL FOR ONLY \$1.00!!**

**WHY SETTLE FOR LESS?!**



### PERFORMANCE, QUALITY, RELIABILITY HIGH PERFORMANCE SYSTEMS DESIGNED TO EXPAND WITH YOUR NEEDS

All CompuPro systems have been designed with your future in mind. Each system is expandable so you can upgrade your system as your needs continue to grow. Hard disk storage is also available with the new DISK 2 DMA Winchester disk controller. Unlike many "personal" computers, your CompuPro system will not become obsolete when it is time to expand. The modular design of the IEEE 696/S-100 bus allows you to plug in additional boards when they are needed. CompuPro system components feature the latest state-of-the-art technology to prevent obsolescence.

Each CompuPro system component is fully assembled and tested under rigorous burn-in conditions at the factory and then shipped to Priority 1 Electronics, your authorized CompuPro Systems Center, for final integration and configuration. CompuPro systems carry the best warranty in the business: on full year. The Qume drives have a full six month warranty, the best drive warranty anywhere. The components are integrated into a complete system by a factory trained Priority 1 Electronics technician. The systems are then partially disassembled for shipping. After a short time for unpacking and check-out, your CompuPro system will be ready to load and go!

#### SYSTEM BASICS

All systems include a CPU 8085/88 Dual Processor or CPU (8085 runs at 6MHz, the 8088 runs at 8MHz); Disk 1 lightning fast DMA floppy disk controller, CP/M<sup>®</sup> 2.2 and CP/M 86<sup>™</sup> operating systems; Sorcim's SuperCalc-86<sup>™</sup> electronic spread sheet program; two double-sided, double-density Qume DT-8 disk drives in an attractive desk top enclosure; rugged Desk Enclosure 2 with 20 slot actively terminated motherboard, fan, air and line filters, and constant voltage power supply for years of reliable operation; internal I/O cables and floppy disk data cable; complete documentation for each system component with a system integration guide. In addition to the above hardware and software, each configuration adds a unique combination of RAM, I/O, and other special purpose boards.

#### System 816/A — Entry Level Single-User System

System 816/A is an excellent choice for an entry level, single user system that's designed with future expansion in mind. 816/A includes Interfacar 4 (three serial I/O ports, parallel port, and Centronics/Epson-style port), two RAM 17s for 128K of fast, static memory, and System Support 1 (clock/calendar, RAM/ROM/match processor options, RS-232C serial port, interrupt controllers, interval timers, and more), and Ashton-Tate's dBase Junior<sup>™</sup>, an upgradeable subset of their popular dBase II data base management software. This combination of components means superb computing today with an option for future expansion — all the way up to a multi-user system. System 816/A is priced at \$5495.00, a savings of over \$1000.00 compared to all components purchase separately.

**BIGBTSYS816ADA** Single User System Desk Top, Assembled & Tested **\$5495.00**  
**BITLV910\*** or **BITLV910BLK\*** TeleVideo 910 or 910 BLK with purchase of above system **\$1.00**

#### System 816/B — M-Drive Single user System

System 816/B is an ultra-high performance single user system which includes Interfacar 3-5 (five serial ports), 256K of fast, static RAM, System Support 1, and Ashton-Tate's complete dBase II<sup>™</sup> data base management software. Plus, System 816/B's implementation of CP/M<sup>®</sup> includes M-Drive software, which turns the system RAM into a pseudo-disk drive for exceptionally fast computing. This system sells for only \$6995.00, a savings of over \$1800.00 compared to all components purchased separately.

**BIGBTSYS816BDA** M-Drive System Desk Top, Assembled & Tested **\$6995.00**  
**BIPDBTLV9252P\*** TeleVideo 925 w/2nd page of memory - with purchase of above system **\$1.00**

#### System 816/C — Entry Level Multi-User System

System 816/C is the only high performance multi-user system which allows both 8 and 16 bit programs to run simultaneously, it also makes for an unparalleled single user system. It includes Interfacar 3-8 (eight serial ports), 384K of fast, static RAM, System Support 1, dBase II<sup>™</sup>, SuperCalc-86<sup>™</sup>, M-Drive software, and CompuPro's MP/M 816<sup>™</sup> multi-user operating system that allows you to run both 8 and 16 bit software *simultaneously*. System 816/C supports up to three users simply by adding appropriate terminals; for more users, just add more CompuPro RAM and terminals. The system is priced at \$8995.00, a savings of over \$2300.00 compared to all components purchased separately.

**BIGBTSYS816COA** Multi-User System Desk Top, Assembled & Tested **\$8995.00**  
**BIPDBTLV9252P\*** TeleVideo 925 with 2nd page of memory - with purchase of above system **\$1.00**

\*Limit 1 terminal at \$1.00 per system. Purchase of 8' RS232 Cable, Part Number **CNDW523220F** at \$19.95, is required for system/terminal integration.

Rack mount and CSC systems are also available; please call or write for details. All CompuPro systems are shipped via motor or air freight collect; please specify at time of order. All boards are shipped in standard configurations.

\*CP/M, CP/M 86, and MP/M are trademarks of Digital Research. MP/M 816 is used under license from Digital Research. SuperCalc-86 is a trademark of SORCIM. dBase II and dBase Junior are trademarks of Ashton-Tate.

**5" DISKETTES  
SOFT SECTOR  
40 TRACK SINGLE SIDED  
DOUBLE DENSITY WITH  
HUB REINFORCING RINGS  
PKG. OF 10/\$19.95**

**BONUS!**

**FREE!! CASSETTE 10  
LIBRARY CASE WITH  
PACKAGE OF 10 DISKETTES  
at \$4.25 VALUE**



Part No.	Description	Price
BIPR180	package of 80 less Library Case	\$120.00
BIPR180D	package of 108" S.S./D.D. Diskettes no sleeves	\$20.00
5 or more packages.....		\$18.99

**SMITH-CORONA TP-1  
LETTER QUALITY -  
ELECTRONIC TEXT  
PRINTER**

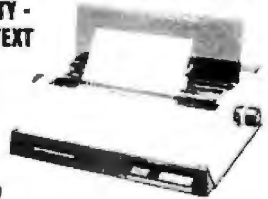

**\$649.00**  
**BISCM7P1S10** (Serial)  
**BISCM7P1P10** (Parallel)  
• 12 CPS • 10 CPI • 6LPI • SERIAL OR PARALLEL INTERFACE  
• 50-19.2K Baud • Friction Feed • 88 Character  
**BISCM12625** TP1 Black Milar Ribbon **\$3.50**  
**BISCM12658** TP1 Black Fabric Ribbon **\$7.50**



**FCC CLASS 2  
APPROVED  
DATA DISPLAY  
MONITORS**



**SPECIFICATIONS:**  
**Viewing Screen** 12" diagonal; 75 square inches  
DM2112: P31 phosphor  
**Scanning System** 525 lines; 60 fields/second; overscan  
**Horizontal Resolution** 600 lines, center  
**Signal Input** 1.0 volt p-p composite video; 75 ohms

#### BISYODM2112

List Price: \$160.00 **SALE: \$119.00**  
**OTHER SANYO MONITORS ON SALE TOO!!**

Part No.	Description	List Price	SALE
BISTOYB4509	9" B&W P4, 10MHz (15 lbs)	\$190.00	\$140.00
BISTOYB5100CX	9" Green, P31, 10MHz (15 lbs)	\$200.00	\$150.00
BISYODM0012CX	12" B&W P4, 18MHz (24 lbs)	\$250.00	\$185.00
BISYODM0112CX	12" Green, P31, 18MHz (24 lbs)	\$260.00	\$188.00
BISYODM0013	13" Color, 16 x 64 (35 lbs)	\$470.00	\$375.00
BISYODM0113*	13" RGB Color (35 lbs)	\$895.00	\$785.00

\*As used with IBM P.C.

#### APPLE DISK DRIVES



Give your APPLE II<sup>®</sup> a Fourth Dimension — the totally compatible 5 1/4" drive that takes your system farther, faster. With read/write electronics so advanced that reading errors are virtually eliminated. With a track zero microswitch that keeps boot and track access smooth and quiet. With the ability to read half-track software and up to 143,360 bytes on DOS 3.3\*. With similar performance on DOS 3.2.1\*, Pascal<sup>™</sup> or CP/M<sup>®</sup> operating systems. And, the disk enclosure mates perfectly with APPLE cabinetry.

#### EXTENDED WARRANTY

Fourth Dimension offers a 12 month parts and labor warranty at no cost to you! (Gee, this really looks good!)

**BIFD540A** List Price: \$419.00 **SALE: \$369.00**  
**2 or More, only \$350.00 each**

**BIFD540AC\*** APPLE II<sup>®</sup> Disk Drive Controller **\$115.00**  
\*Sold only with purchase of Fourth Dimension Drive



**FUJITSU FROM SELLUM  
LETTER QUALITY PRINTERS**

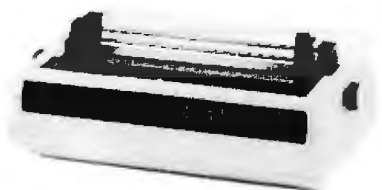

**80 CHARACTERS PER SECOND**

The Fujitsu SP83 letter quality printer from Sellum is not only the fastest daisy wheel letter quality printer on the market, it is also the most versatile. Its four interfaces and five personality protocols make it compatible with just about any computer and word processing package on the market today. The printer is built to be solid and quiet; it won't shake the office down with every carriage return. It also has a 16K buffer (48K optional). The buffer allows your computer to send data out to the printer and not have to wait for it before allowing you to continue. No more staring at the screen waiting for the printer to finish!

**Interfaces:** • RS232C and Current Loop • Centronics type parallel • IEEE488 • All are DIP switch selectable

**Personality Protocols:** • NEC5510 • DIABLO 630 • QUME Sprint 9 • IBM Personal Computer • ATARI (Centronics 737)

**More Special Features:** • 280 CPU • 50-19.2K baud on serial interface • Distinct alarm sound for each error condition • Intelligent bi-directional logic seeking • Complete word processing features including sub and super script, underlining, and double-strike characters • Auto reprint • Auto Clear • Proportional spacings and supports automatic justification • Front panel forms control • 12K ROM • Complete Vector plotting routines • Compatible with most mechanical sheet feeders • Quiet - 60db • Six month warranty

Part No.	Description	List Price	Our Price
BISLNF06	Printer w/16K Buffer	\$3495.00	\$2795.00
BISLNF06A4	Printer w/48K buffer	\$3895.00	\$3095.00
BISLNF06FT	Optional vertical forms tractor		\$200.00
BISLNF025000	RS-232 Cable		\$86.00
BISLNF038001	Centronics Parallel Cable		\$80.00

Call for pricing on sheet feed options & cables not listed (Printer shipped via motor freight collect)

**Para Dynamics**



**18 SLOT S-100 MAINFRAME**

CVT Power Supply, forced air cooling; security lock 120 or 220V AC at 50 or 60Hz+8V@20A, ±16@3.5

BIPDR2010	Desk Top	\$799.00	\$699.00
BIPDR2018	Rack Mount	\$849.00	\$749.00

**8 SLOT S-100 MAINFRAME WITH**

**CUTOUTS FOR 2 5 1/4" DISK DRIVES**

+5@5A, -5@500MA, +8@15A, +12@6A, +16@2, -16@2			
BIPDR2580	Desk Top	\$899.00	\$799.00
BIPDR258R	Rack Mount	\$949.00	\$849.00

**DISK DRIVE FACILITY**

Accommodates two 8" floppy drives, of Shugart, Qume, or similar design and dimensions. 110 or 220V AC at 50 or 60Hz CVT power.

BIPDR2200	Desk Top	\$659.00	\$579.00
BIPDR220R	Rack Mount	\$679.00	\$595.00

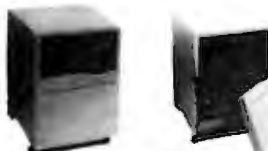

**PRONTO**

Free standing cabinet. Will accept 2, 8" Floppy disks and 1, 8" rigid disk. 18 slot card cage will accept the double height 10" x 10" S-100 cards (Alpha Micro and others) CVT Power Supply.

+24@7A, +16@2.2A, -16@3.5A, +8@20A, +5@5A			
BIPDR218	PRONTO	\$1295.00	\$1129.00
PRONTO COMPLETE WITH POWER SUPPLY POWER-UP SEQUENCER			
with sequencer		\$1395.00	\$1249.00

Shipped motor freight collect

Circle 379 on Inquiry card.

**FREE TRACTOR AND  
FREE OKIGRAPH!!  
OKIDATA**



**COMPARE OKIDATA'S FEATURES  
TO ANY OTHER PRINTER!  
COMPARE PRIORITY ONE'S PRICES  
TO ANY - THEN DECIDE!**

Don't be fooled by those who try to "soak" you for the options

- BI-DIRECTIONAL: 120 CPS • 80 CPL @ 10CPI for 82A
- 9 x 8 Matrix (Alphanumeric) • 132CPL @ 10CPI for 83A&84
- 6x9 or 12 Matrix for graphics • 82A & 83A have both Centronics Parallel & 1200 baud Serial I/O
- 10 different character sets • Sell Test

All three printers feature 10 front panel switch selectable for lengths: 10 lengths from 3" to 14" Front or bottom paper loading of up to 4 part forms and tear bar All of these features make OKIDATA the best value in low cost printers!

Part No.	Description	List Price	SALE
BIPDR082ATG	Okidata 82A w/tractor and graphics	\$539.00	
BIPDR083ATG	Okidata 83A w/tractor & graphics	\$750.00	
BIPDR082RF	9600 Baud 2K serial buffer/interface with simultaneous purchase of printer	\$150.00	\$ 99.00
BIOKIDAT84AP	132 column printer parallel interface with graphics and tractor	\$1019.00	
BIOKIDAT84AS	132 column printer 9600 baud serial 2K interface, graphics, and tractor	\$1119.00	
QUMDRAPLINTC*	Apple Parallel Interface w/Cable	\$75.00	

\*Sold only with printer

**COMPARE PRICES!!**

**ADDS**  
Applied Digital Data Systems Inc.

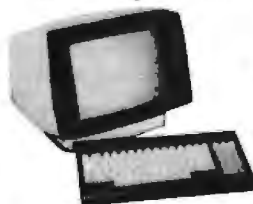

**SALE!**  
Green Screen  
**\$525.00**  
Black & White  
**\$479.00**

**VIEWPOINT - ADDS**

Detachable keyboard, RS232 interface and auxiliary port. 80 x 24 display, tiltable screen.

BIA00VPR	ADDS 3A, P31 Green Phosphor	\$699.00	\$525.00
BIA00VPRW	P4 Black & White	\$699.00	\$479.00

**VISUAL 50**

- Low profile detached keyboard features sculptured keys with matte finish
- Screen tilts and swivels
- 80 x 24 display with 25th status line
- 7 x 9 dot matrix with full decoders
- RS-232 Serial interface w/auxiliary RS-232 port
- 128 Character ASCII set and 31 character line drawing set



**INTRODUCTORY OFFER!!**

BIVLS00W	Non glare Black & White	\$695.00	\$650.00
BIVLS00R	P31 green display	\$750.00	\$685.00

(Shipping Weight 37 lbs.)

**SEND \$1.00 TODAY  
FOR THE NEW, FULL COLOR  
SPRING 1982 ENGINEERING  
SELECTION GUIDE!**



**PRIORITY ONE ELECTRONICS**

9161 DEERING AVE • CHATSWORTH, CA 91311

**ORDER TOLL FREE (800) 423-5922 - CA, AK, HI CALL (213) 709-5464**

Terms: U.S. VISA, MC, BAC, Check, Money Order, U.S. Funds Only CA residents add 6 1/2% Sales Tax. MINIMUM PREPAID ORDER \$15.00. Include MINIMUM SHIPPING & HANDLING of \$3.00 for the first 3 lbs., plus 25¢ for each additional pound. Orders over 50 lbs. sent freight collect. Just in case, please include your phone number. Prices subject to change without notice. We will do our best to maintain prices through September, 1982. Credit Card orders will be charged appropriate freight. If you haven't received your Spring '82 Engineering Selection Guide, send \$1.00 for your copy today! Sale prices are for prepaid orders only.

**Tandon**

Tandon 8M-800 Thinline is exactly half the size of conventional 8" floppy disk drive.



Exactly one-half the height of any other model. Proprietary, high-resolution, read-write heads patented by Tandon.

D.C. only operation - no A.C. required. Industry standard interface.

Three millisecond track-to-track access time (9 lbs.)

BITNDTM441	Single Sided \$380.00	2 or more \$370.00
BITNDTM442	Double Sided \$485.00	2 or more \$485.00

**TANDON 5 1/4" DRIVES**

BITNDTM1001*	Single Sided, 250KB (5 lbs.)	\$ 105.00 ea
	2 or More \$180.00	
BITNDTM1002*	Double Sided, 500KB	\$295.00 ea.
	2 or More \$270.00	
BITNDTM1003	Single Sided, 500KB	\$295.00 ea.
	2 or More \$270.00	
BITNDTM1004	Double Sided, 1000KB	\$365.00 ea.
	2 or More \$375.00	

\*As used in the IBM P.C.

**MITSUBISHI ELECTRIC**



Better Than QUME!  
Better Than SHUGART!

8", Double-sided, double-density, interchangeable with QUME & Shugart

BIMITM2084B3	Sh. Weight 16 lbs.	\$499.00
BIMITM2084B3	M Manual	\$ 16.00

2 or More \$475.00 each

**A. Shugart 801R**

Single sided, double density - most popular 8" drive

BISHUG01R	\$394.00 ea. or 2 or more (16 lbs) for \$389.00	
BISHUG001RM	Manual for 801R drives	\$ 10.00

**INTERNATIONAL INSTRUMENTATION, INC.**

**OUR BEST!!**



**UNIVERSAL DISK ENCLOSURES**

• Accepts any combination of 8" drives (QUME/Shugart 801R type or 1/2 size Tandon type) • Also accepts hard disks • Positive pressure • Optional Disk environment monitor shows supply voltage and internal cabinet temperature • Internal power and data cables provided.

UNIVERSAL DRIVE CABINET complete with power supply, fan and filter, and all internal cables for attachment of two 8" floppy drives.

BIIUD004	Dual Drive Cabinet (Sh. Wt. 40 lbs)	\$495.00	\$450.00
BIIUD004E	With purchase of two 8" Desk Drives		\$399.00
BIIUD004EM	w/Environmental Monitor installed	\$584.95	\$535.00
BIIUD004EM	With purchase of two 8" Desk Drives		\$485.00
BIIUD004RUR	Dual Drive cabinet with Augmentation power supply module to increase 5V supply from 5 amps to 9 amps for use with two hard disks or 4 Tandon drives. Also includes Desk Environment Monitor (45 lbs)	\$733.00	\$690.00
BIIUD004RUR	19" Rack Mount kit UDE004		\$ 89.95

THIN THREE DRIVE CABINET complete with power supply, and all internal cables for attachment of three thin 8" floppy drives (Tandon type). One AC power connector is also provided for use with full size drive.

BIIID00TT Three Drive Cabinet (Sh. Wt. 35 lbs) \$495.00 \$450.00

BIIID00TTM with Environmental Monitor installed \$584.95 \$535.00

5 1/4" CABINETS - VISTA

BIVISS001 Single 5" with P.S. \$ 85.00

BIVISS002 Dual 5" with P.S. \$110.00



# SPECIAL PURCHASES!



## 64K IEEE-S100 DYNAMIC MEMORY CARD

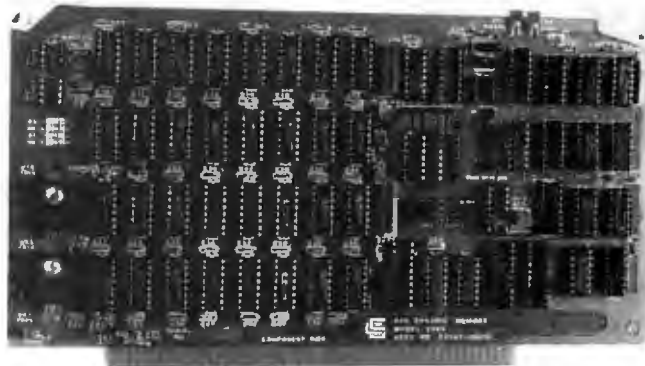

- 2 or 4 MHz operation
- Designed to IEEE proposed S-100 bus standards
- Supports IMSAI-type front panels
- Operates with either an 8080 or Z-80 based S-100 system providing processor-transparent refreshes with both
- Bank-select system allows system memory expansion
- Bank-select port's address is jumper selectable
- Any 16K block can be made bank-independent
- All 64K can be made bank-enabled on power-on and reset
- Fully buffered address and data lines

- Configuration as a 16K, 32K, or 48K board without the removal of RAMs
- Fail-safe refresh circuitry for extended Wait States
- Board configuration with reliable easy-to-configure Berg jumpers
- Supports DMA
- Jumper-selectable Phantom input
- Uses Popular 4116 RAMs
- Assembled & tested
- All ICs in sockets
- Full Factory Warranty

**SAVE  
\$130.00!!**

**BICCS20653**

SHIPPING WEIGHT 2 lbs.

LIST PRICE: \$350.00

SAVE \$130.00!!

**\$249.00 ea or 4/\$880.00**

## CompuPro **RAM 21**

### 128K 12MHz S-100 STATIC MEMORY 8 OR 16 BIT

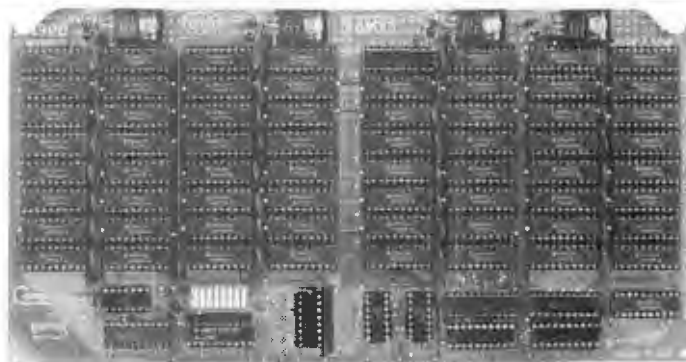

The days of "Out of Memory" are gone at last! CompuPro has introduced the largest static S-100 IEEE/696 RAM board ever to be produced. The RAM 21 is arranged either as a 128K x 8 bit wide or 64K x 16 bit wide board, using a high speed, ultra low low power proprietary static RAM. CompuPro has also included 24 bit addressing for up to 16 megabyte capability and power consumption so low your mainframe will never know it's there!

- Meets or exceeds all IEEE 696/S-100 specifications
- Fully static design uses less power than dynamics (1.2 amps typical)
- 24 bit extended addressing
- 8 bit (128K) or 16 bit (64K) operation
- Addressable as one block
- 16K window deselect, dip switch selectable
- Switch selectable PHANTOM disable
- 12 MHz CPU operation
- 16K x 1 static RAM
- Thorough bypassing of all supply lines
- Capable of DMA processing
- 128K Static, 1.2 amps
- NMOS high speed low power memory ICs

**BIGBT190A**

List Price: \$1695.00

**SALE PRICE:**

**\$995.00**

**SAVE \$700.00!!**



Circle 380 on Inquiry card.

SEE IMPORTANT NOTICE ON PAGE 604



# WE JUST BURNED TANDON'S PRICE SHEET!

SPECIFICATIONS:	TM100-1
TPI	48
Tracks/Diskette	40
Capacity Per Side (unformatted) Double Density	250KB
Access Time	
Track-to-Track Average	5 ms
Head Settle Time	75 ms
	15 ms
Mechanical Dimensions:	
Width: 5.75 in. Height: 3.25 in. Depth: 8.00 in.	
DC Voltage Requirements	+12V±5
Current Requirements	900mA/600mA

BITND1001 Bare Drive	
Qty - 1	\$195.00 ea.
2 - 9	\$180.00 ea.
10 - 24	\$170.00 ea.
25+	\$160.00 ea.

OEM and Dealer Inquiries invited  
(Shipping Weight 4 lbs. each)

Priority One Electronics has burned up Tandon's price sheet with our special purchase of Tandon TM100-1 5 1/4" 40 track double density disk drives! We purchased a large quantity of new, factory-sealed drives from a large OEM who simply bought too many. This is strictly a "one-shot" deal, when these are gone there will be no more! In fact, we are selling these drives below our regular cost as a volume purchaser! At these low prices, these drives will not last long! So, if you ever thought of expanding the disk capacity of your computer, now is the time!

Tandon drives are known throughout the industry for their quality and reliability. That is why major computer manufacturers such as IBM have chosen Tandon drives for inclusion in their products. The TM100-1 is the same drive used in IBM's Personal Computer. Now you can add more disk storage to your PC and save hundreds of dollars! But you don't have to own an IBM Personal Computer to take advantage of this incredible Tandon sale! The Tandon TM100-1 has the industry standard interface for 5 1/4" drives so it is compatible with just about every computer on the market!

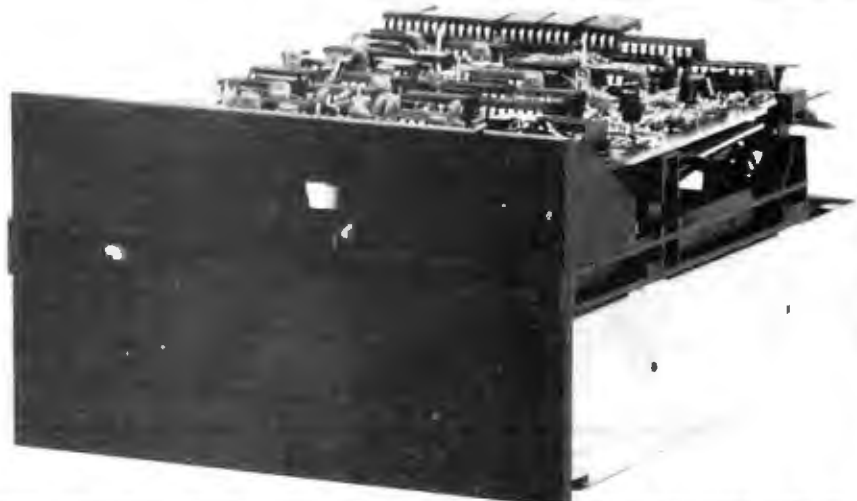

## NO ONE CAN TOUCH US!

WE ARE THE NATION'S LARGEST  **HITACHI** DISTRIBUTOR  
Hitachi Denshi, Ltd.



**WE WILL BEAT ANY ADVERTISED PRICE ON HITACHI OSCILLOSCOPES!!  
CALL FOR PRICES TOO LOW TO PUBLISH!!**

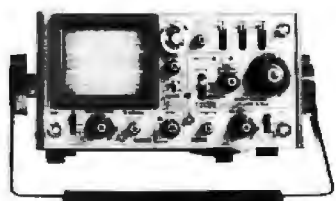

HERE IS ONE EXAMPLE...  
**BIHITV550B**  
50MHz DUAL TRACE WITH 3RD TRACE TRIGGER VIEW  
LIST PRICE \$1745.00  
**SALE:**  
**\$995.00**

**BIHITV1050**  
100MHz DUAL TRACE WITH 3RD & 4TH TRACE TRIGGER VIEW  
**CALL**  
**BIHITV352**  
35MHz DUAL TRACE WITH DELAY  
**BIHITV202**  
20MHz DUAL TRACE  
**CALL**

**BIHITV302**  
30MHz DUAL TRACE INTERNAL DELAY LINE  
**BIHITV152**  
15MHz DUAL TRACE  
**CALL**

**BIHITV509**  
50MHz DUAL TRACE WITH CALIBRATED VARIABLE DELAY  
**CALL**  
**BIHITV209**  
20MHz DUAL TRACE WITH 2 HOUR BATTERY BACK-UP  
**CALL**

- ACCESSORIES**
- BIHITC1530 Dust Cover for V302 & V152 \$35.00
  - BIHITC2035 Dust Cover for HITV202 & V352 \$35.00
  - BIHITC5010 Front Cover for HITV550B & V1050 \$18.00
  - BIHITAP5010 Accessory Pouch for HITV550B & V1050 \$40.00
  - BIHITV1050M HITV1050 Service Manual \$58.00
  - BIHITV1520M HITV152B Service Manual \$50.00
  - BIHITV202M HITV202 Service Manual \$50.00
  - BIHITV3020M HITV302B Service Manual \$50.00
  - BIHITV352M HITV352 Service Manual \$50.00
  - BIHITV5500M HITV550B Service Manual \$50.00
  - BIHITC5010 Vinyl Cover for HITV1050 & V550B \$30.00

- \$35.00
- \$35.00
- \$18.00
- \$40.00
- \$58.00
- \$50.00
- \$50.00
- \$50.00
- \$50.00
- \$30.00

**1 PRIORITY ONE ELECTRONICS**  
9161 Deering Ave., Chatsworth, CA 91311

**ORDER TOLL FREE (800) 423-5922 - CA, AK, HI CALL (213) 709-5464**  
Terms: U.S. VISA, MC, BAC, Check, Money Order, U.S. Funds Only. CA residents add 6 1/2% Sales Tax. MINIMUM PREPAID ORDER \$15.00. Include MINIMUM SHIPPING & HANDLING of \$3.00 for the first 3 lbs. plus 40¢ for each additional pound. Orders over 50 lbs. sent freight collect. Just in case, please include your phone number. Prices subject to change without notice. We will do our best to maintain prices through September, 1982. Credit Card orders will be charged appropriate freight. If you haven't received your Spring '82 Engineering Selection Guide, send \$1.00 for your copy today! Sale prices are for prepaid orders only.

Circle 380 on Inquiry card.

**SEE IMPORTANT NOTICE ON PAGE 604**

1 ONE

**SIERRA DATA SCIENCES**

&

**MICROPOLIS™**

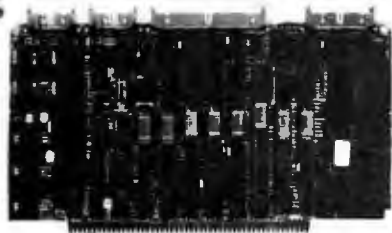

**SBC MASTER PROCESSOR**

This is absolutely the most complete single board computer available. **NO EXTERNAL INTERFACE BOARDS ARE NEEDED!**

- Z80A CPU
- 64K Bank Switchable Memory
- 4K EPROM
- Auto Boot
- NEC 765 FDC with PLL interface to all Shugart compatible drives (5 1/4" or 8")
- 2 RS-232C Serial ports (Z80ASIO, up to 19.2K BAUD)
- 2 parallel Ports (Z80 APIO)
- 4 Timers (Z80ACTC)
- IEEE 696/S-100 Compatible
- CP/M and TURBODOSS compatible
- ALL SIERRA PRODUCTS CARRY A FULL ONE YEAR WARRANTY

The Sierra SBC was designed to meet the needs of single-user systems as well as multi-user systems in a number of configurations (i.e., Time sliced single processor operation, loosely coupled multi-processor operation, etc.) This flexibility provides SBC users with a natural growth path without the need to discard previous system components in most cases. In turn, users with larger requirements may build sophisticated multi-user systems right from the start.

**SBC MASTER PROCESSOR WITH OPTIONAL MICROPOLIS 8" WINCHESTER HARD DISK INTERFACE!**

An optional Intelligent Winchester Adapter allows the Sierra SBC to be interfaced to a Micropolis MicroDisk™. This allows the user to add reliable mass storage at a reasonable price.

As an added bonus during our September SALE, Priority One Electronics will supply the Sierra version of CP/M® 2.2 at no additional charge. **THAT'S A SAVINGS OF \$200.00!!!**

**BIPDBSCCPM** A&T w/BIOS & CP/M® 2.2 List Price \$1095.00

**SALE: \$895.00**

**SBC SLAVE PROCESSOR**

Similar to above with 16K EPROM, X-Buss Expansion Interface and optional on board EPROM burner.

- Z80A CPU
- 64K Bank Switchable Memory
- 16K EPROM
- 2 RS-232C Serial ports (Z80ASIO, up to 19.2K Baud)
- 4 Parallel Ports (Z80APIO)
- 4 Timers (Z80ACTC)

**BIPDBSCSL** Assembled & Tested List Price \$795.00

**SALE \$750.00**



**SDS MICROPOLIS HARD DISK INTERFACE**

Micropolis 1220/1260 microDisk series interface adapter with software drivers, cabling, and mounting hardware.

**BIPDBSDI** Assembled & Tested List Price \$150.00

**MICROPOLIS 12631 45MB 8" WINCHESTER DISK**

The Micropolis MicroDisk is an 8" three platter disk with 36Mb formatted capacity. Winchester technology is incorporated in the MicroDisk design, which is packaged in two sections. The lower half, which contains the three platters, disk heads, and positioner, is completely sealed for years of reliable operation. The upper half, which is accessible for maintenance, contains four circuit boards, including the Micropolis intelligent controller. The drive is shock mounted in attractive Micropolis desk top enclosure with power supply.

**BIMCP12631** Assembled & Tested List Price \$6629.00

(Shipped Motor Freight Collect)

**SALE \$3995.00**

**SIERRA/MICROPOLIS SBC PACKAGE**

Sierra SBC, CP/M, Micropolis Interface, and Micropolis 12631 MicroDisk.

**BIPDBSCSTB1** Shipped Motor Freight Collect List Price \$6629.00

**SALE \$4495.00**

**QT COMPUTER SYSTEMS INC.**

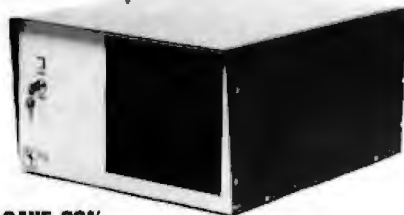

**SAVE 20% S-100 MAINFRAMES FOR DUAL 8" HARD AND FLOPPY DISKS**

The Q.T. MFD series mainframe is designed to be the most versatile and the most compact system enclosure on the market today. In addition to a 6, 8, or 12 slot S-100 card cage, the mainframe is designed to support two 8" floppy or hard disk drives. It is ideal for the new generation of Single Board Computers and highly density RAM cards that do not require many slots. Now you can have a complete dual floppy or hard disk system in one convenient enclosure at a remarkably low price.

**FEATURES:**

- Accommodates any combination of standard 8" floppy or hard disk drive (801R, DTB, Fujitsu hard disk, etc.)
- IEEE S-100 Silence+ 6, 8, or 12 slot motherboard available for quiet operation with high speed processors
- Keypad power Switch
- Reset Switch on Front Panel
- Anodized 6, 8, or 12 slot card cages
- Quiet fan with filter provides cool clean systems operating featuring positive air pressure
- Detachable line cord plugs directly into EMI noise filter for electrical noise suppression
- Two AC convenience outlets on rear panel for peripherals
- 15-DB25 out outs for mounting I/O connectors
- 2-50 pin plug out outs
- Dimensions: 9 3/4" x 17" x 21" (HxWxD) (Sh. Wt. 48 lbs.)
- Power Supply +15@7A, +24V@7A, +8@18A, ±18@3A, 5@1A

Part No.	Description	List Price	SALE Price
BQTCMF00	without Motherboard	\$600.00	\$480.00
BQTCMF06	with 6 slot Motherboard	\$675.00	\$540.00
BQTCMF08	with 8 slot Motherboard	\$700.00	\$560.00
BQTCMF12	with 12 slot Motherboard	\$750.00	\$600.00

**QT MAINFRAMES SAVE 10%**

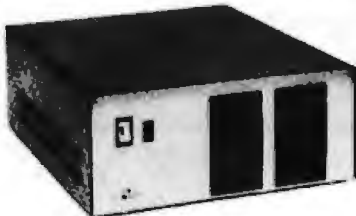

**MF+MD (Accepts 2 5 1/4" Disk Drives)**

Includes cabinet, IEEE S-100 motherboard (6, 8, or 12 slot) and dual mini-disk provision with disk drive power supply. The hefty power supply is rated at +16V@18A, ±12@3A, and ±16V@3A. The QT MF+MD is fan cooled, has AC line filter to eliminate EMI and is fully factory assembled and tested. Power and reset switches are located on the front panel. AC Convenience outlets, twelve DB25 cutouts and two 50 pin plug cutouts are on the rear panel.

Part No.	Description	List Price	SALE Price
BQTCMF00	without motherboard	\$425.00	\$382.50
BQTCMF06	with 6 slot motherboard	\$500.00	\$450.00
BQTCMF08	with 8 slot motherboard	\$550.00	\$495.00
BQTCMF12	with 12 slot motherboard	\$600.00	\$540.00

The above mainframes are also available with an optional augmentation supply for 5 1/4" hard disks; add the suffix MD to the above part numbers and add \$150.00 to the price.

**QT MF+**

This cabinet is similar to above but without the cutouts for 5 1/4" disks. Power Supply: +8V@18A, ±16V@3A

Part No.	Description	List Price	SALE Price
BQTCMF	without motherboard	\$400.00	\$360.00
BQTCMF6	with 6 slot motherboard	\$450.00	\$405.00
BQTCMF8	with 8 slot motherboard	\$500.00	\$450.00
BQTCMF12	with 12 slot motherboard	\$550.00	\$495.00

(Shipping Weight 40 lbs.)

**QT SINGLE 8" DISK CABINET**

Accepts one 8" disk drive (Shugart, Remex, PerSci, Siemens, etc.). Fan cooled with AC line filter to eliminate EMI!

Part No.	Description	List Price	SALE Price
BQTCSD00	For single 8" floppy disk	\$250.00	\$225.00
BQTCSD08	For 8" hard disk or tape streamer	\$295.00	\$265.50
BQTCSD07	For 2 Tandem Thinlike drives	\$295.00	\$265.50

(Shipping Weight 22 lbs.)

**QT DUAL 8" DISK CABINET**

Capable of powering one Winchester hard disk and one floppy disk, simultaneously. Accepts two 8" disk drives (Shugart or size equivalent). Fan cooled. (5@1A, +5V@3A, +24V@3A)

Part No.	Description	List Price	SALE Price
BQTCDD08H	Horizontal Mount (Sh. Wt. 24 lbs.)	\$360.00	\$325.00

**CLOCK CALENDARS FOR S-100, APPLE, AND TRS-80**



**SAVE 10%**

The Clock/Calendar+ utilizes the popular MSM5832 real time Clock/Calendar chip designed for use in bus-oriented microprocessor applications. The 32.768MHz crystal controlled time base will provide addressable 4-bit I/O data of SECONDS, MINUTES, HOURS, DAY OF WEEK, DATE, MONTH, YEAR. The data access is controlled by a 4-bit address, read, write, and hold inputs. Z80 or 6080 compatible. 18 Month battery back-up on board.

Part No.	Description	List Price	SALE Price
BQTCCE0A	S-100, A&T	\$165.00	\$148.50
BQTCCE0A	Apple II, A&T	\$150.00	\$135.00
BQTCCE0B00	TRS-80, A&T	\$150.00	\$135.00

**SBC 2/4 Z80 S-100 SINGLE BOARD COMPUTER**

The QT Computer SBC 2/4 Processor Board is a versatile and powerful Z80 based design which is compatible with the proposed IEEE S-100 bus standard. Although the SBC 2/4 may be used as the host CPU of a large system, it has all the necessary features to be used as a standalone computer system.

- Z80A 8 bit CPU
- 2 or 4 MHz Switch selectable
- 1K RAM (which can be located at any 1K boundary)
- One parallel I/O port
- One serial I/O port
- Power on jump to on board 1K or 2K boundary
- Full 64K use of RAM allowed in shadow mode
- DMA compatibility allows MWRIT signal generation on CPU board or elsewhere in system under DMA logic or front panel control
- Two programmable timers available for use by programs run with the SBC+2/4 timer output and controls available for use on CPU board.

(Shipping Weight 2 lbs.)

Part No.	Description	List Price	SALE Price
BQTCSC24A	Assembled & Tested	\$325.00	\$290.00

Circle 381 on Inquiry card.



## NEW 4 1/2 DIGIT HANDHELS!

The FLUKE 8060A and 8062A offer the most powerful combination of capabilities ever in a handheld DMM, including these:

- 4 1/2 digit resolution
- 10µV V, 10mA, 10M sensitivity
- 100KHz True RMA (8060A)
- 30KHz True RMS (8062A)
- Relative Reference
- Constant current diode test
- Self diagnostics
- Basic DC accuracy of 0.04% (8060A); 0.05% (8062A)

The 8060A also offers dBm, relative dB, frequency measurements to 200KHz, Auto ranging megohms to 300kΩ, and conductance (2000 nS).

**BIFLU8000A** with safety designed test leads \$349.00  
**BIFLU8002A** with safety designed test leads \$279.00

## 3 1/2 DIGIT HANDHELS: THE WORLD STANDARD

- dc voltage
- ac voltage
- dc current
- ac current
- resistance
- diode test
- conductance
- high-speed continuity beeper
- temperature (via K-type thermocouple)
- peak hold on voltage and current
- functions 0.1% basic dc accuracy (8024B & 8020B) 0.25% basic dc accuracy (8021B & 8022B)
- visual logic level detector
- and continuity indicators

Extensive overload 3 1/2-digit resolution protection with 600V double-fused current input. Safety-designed test leads. Two-year parts and Two-year labor warranty Calibration Cycle.

**BIFLU8024B** (All 11 functions) \$239.00  
**BIFLU8020B** (First 8 functions) \$189.00  
**BIFLU8021B** (First 7 functions) \$149.00  
**BIFLU8022B** (First 6 functions) \$139.00

## page NC Drilled Prototyping Boards



### S-100 BOARDS

PART NO.	DESCRIPTION	PRICE		
		1-4	5-9	10-24
BIPBP1001	\$100 Bare Board	\$18.95	\$13.95	\$11.95
BIPBP1002	\$100 Horizontal Busses	\$22.95	\$18.95	\$17.95
BIPBP1003	\$100 Vertical Busses	\$22.95	\$18.95	\$17.95
BIPBP1004	\$100 Pads Per Hole	\$23.95	\$20.95	\$18.95

### APPLE BOARDS

BIPBP5001	Apple Bare Board	\$15.95	\$13.95	\$11.95
BIPBP5002	Apple Horizontal Busses	\$22.95	\$18.95	\$17.95
BIPBP5004	Apple Pads Per Hole	\$23.95	\$20.95	\$18.95

### GENERAL PURPOSE PLUGBOARDS

BIPBP4411	4.5"x6" 22/44 156" Bare Board	\$ 8.95	\$ 8.95	\$ 7.95
BIPBP4413	4.5"x6" 22/44 156" Vertical Buss	\$13.95	\$12.50	\$11.50
BIPBP4414	4.5"x6" 22/44 156" Pads Per Hole	\$14.95	\$13.50	\$12.50
BIPBP4421	4.5"x9.5" 22/44 156" Bare Board	\$10.95	\$ 9.95	\$ 8.95
BIPBP4423	4.5"x9.5" 22/44 156" Vertical Buss	\$14.95	\$13.50	\$12.50
BIPBP4424	4.5"x9.5" 22/44 156" Pads Per Hole	\$15.95	\$14.50	\$13.50
BIPBP7211	4.5"x6" 36/72 1" Bare Board	\$ 8.95	\$ 8.95	\$ 7.95
BIPBP7213	4.5"x6" 36/72 1" Vertical Buss	\$13.95	\$12.50	\$11.50
BIPBP7214	4.5"x6" 36/72 1" Pads Per Hole	\$14.95	\$13.50	\$12.50
BIPBP7221	4.5"x9.5" 36/72 1" Bare Board	\$10.95	\$ 9.95	\$ 8.95
BIPBP7223	4.5"x9.5" 36/72 1" Vertical Buss	\$14.95	\$13.50	\$12.50
BIPBP7224	4.5"x9.5" 36/72 1" Pads Per Hole	\$15.95	\$14.50	\$13.50

## RS232 and "D" SUB-MINIATURE CONNECTORS



SOLDER TYPE

P=Plug, Male Type — S=Socket, Female Type — C=Cover, Hood

PART NO.	DESCRIPTION	PRICE		
		1-9	10-24	25-99
BICNDDE9P	9 Pin Male	\$ 2.10	\$ 1.80	\$ 1.70
BICNDDE9S	9 Pin Female	\$ 2.70	\$ 2.40	\$ 2.10
BICNDDE9C	9 Pin Cover	\$ 1.50	\$ 1.25	\$ 1.10
BICNDDA15P	15 Pin Female	\$ 2.75	\$ 2.45	\$ 2.15
BICNDDA15S	15 Pin Female	\$ 3.95	\$ 3.60	\$ 3.20
BICNDDA15C	15 Pin Cover	\$ 1.50	\$ 1.30	\$ 1.10
BICNDDA25P	25 Pin Male	\$ 3.00	\$ 2.75	\$ 2.25
BICNDDA25S	25 Pin Female	\$ 4.00	\$ 3.75	\$ 3.00
BICNDDBS1212	1 Pc. Grey Hood	\$ 1.80	\$ 1.45	\$ 1.30
BICNDDBS25	2 Pc. Grey Hood	\$ 1.90	\$ 1.25	\$ 1.10
BICNDDBS1228	2 Pc. Black Hood	\$ 1.80	\$ 1.55	\$ 1.45
BICNDDBS37P	37 Pin Male	\$ 8.00	\$ 5.10	\$ 4.45
BICNDDBS37S	37 Pin Female	\$ 8.70	\$ 7.70	\$ 6.70
BICNDDBS37C	37 Pin Cover	\$ 1.80	\$ 1.55	\$ 1.30
BICNDDBS50P	50 Pin Male	\$ 8.75	\$ 7.75	\$ 6.70
BICNDDBS50S	50 Pin Female	\$11.85	\$10.25	\$ 8.90
BICNDDBS50C	50 Pin Cover	\$ 2.80	\$ 1.80	\$ 1.60
BICNDDBS418	Hardware Set 2/Pr RS232, DB25P, EIA	\$ 1.80	\$ .80	\$ .70
BICNDDBS232BF	Class 1 Cable 8 Con 8 Ft	\$18.95	\$17.95	\$15.95
BICNDDBS7303S	Cent. 700 Series/ Epson Printer Conn.	\$ 8.00	\$ 7.50	\$ 6.00
BICNDDBS7308S	IDC Version of Above	\$ 8.85	\$ 8.00	\$ 6.00



## NEW FROM Vector



### IBM PC PROTOTYPING BOARDS

Part No.	Description	1-5	6-24	25*
BIVCT4013	3 Hole Solder Board	\$59.00	\$53.10	\$47.20
BIVCT4013-1	Bare Board	\$37.00	\$33.30	\$29.60
BIVCT4013-2	Wire Wrapping Board	\$99.00	\$53.10	\$47.20
BIVCT3000-22	Extender	\$22.35	\$20.12	

\*IBM is a trademark of International Business Machines

# PRENTICE



## THE STAR OUR MOST POPULAR MODEM

### We've Sold Thousands!

- 0 to 300 baud
- Bell 103 and 113
- Exclusive triple seal acoustic chamber
- Self Test ±0.2% frequency stability, crystal controller
- Receiver Sensitivity of -50dB on -53dB off
- FSK Modulation
- RS232 Compatible
- Switches: Originate/Off/Answer Full Duplex/Test/Half Duplex
- Indicators: Transmit Data, Receive Data, Carrier Ready Test

Part No.	Description	List Price	SALE
BIPINSTAR	RS232, TTL, 20Ma Current Loop	\$199.00	\$127.00

SEND \$1.00 TODAY FOR THE NEW FULL COLOR, SPRING 1982 ENGINEERING SELECTION GUIDE



## PRIORITY ONE ELECTRONICS

9161 DEERING AVE • CHATSWORTH, CA 91311

ORDER TOLL FREE (800) 423-5922 - CA, AK, HI CALL (213) 709-5464

Terms: U.S. VISA, MC, BAC, Check, Money Order, U.S. Funds Only. CA residents add 6 1/2% Sales Tax. MINIMUM PREPAID ORDER \$15.00. Include MINIMUM SHIPPING & HANDLING of \$3.00 for the first 3 lbs., plus 40¢ for each additional pound. Orders over 50 lbs. sent freight collect. Just in case, please include your phone number. Prices subject to change without notice. We will do our best to maintain prices through September, 1982. Credit Card orders will be charged appropriate freight. If you haven't received your Spring 82 Engineering Selection Guide, send \$1.00 for your copy today! Sale prices are for prepaid orders only.

## MICROCOMPUTER PRODUCTS MEMORY 8080 SERIES

PART NO.	PRICE	PART NO.	PRICE
B14118AC20	\$738.00	B14NS0080A	\$5.50
B12018P3	\$722.00	B14NS0085A	\$19.95
B12114N3L	\$728.00	B10P8212N	\$2.95
B15257N3L	\$750.00	B10P8214N	\$5.25
B12732	\$798.00	B10P8218N	\$2.95
B12716	\$748.00	B10P8224N	\$3.25
B12708	\$720.00	B10P8224-4N	\$9.85
		B10P8226N	\$3.50
		B10P8226N	\$5.55
		B10P8238N	\$5.55
		B14NS0250N	\$15.95
		B14NS0251N	\$7.50
		B14NS0253N	\$17.95
		B14NS0255N	\$8.80
		B14NS0257N	\$16.45
		B14NS0259N	\$18.00
		B14NS0259N	\$59.95
		B14NS0275N	\$59.95
		B14NS0278N	\$24.95
		<b>FLOPPY DISC CONTROLLER</b>	
		B14F17718-01	\$24.95
		B14F17918-01	\$44.95

PROTECT YOUR INVESTMENT PROTECT YOUR DATA WITH

## ISOBAR

With Built-In Noise Filters and Surge Suppressors



**ISOLATES SENSITIVE AND VALUABLE EQUIPMENT FROM:** Equipment interaction - Damaging High Voltage Spikes - AC line noise and hash. **PROTECTS AGAINST:** Voltage transients caused by lightning, contact switching, turn-off of inductive components, noise due to electromagnetic coupling. **USE THE GSC ISOBAR TO ISOLATE:** Microprocessor from peripherals - Lab instruments from noisy equipment - Sensitive pre-amp or tape deck from power amplifier. **THE GSC ISOBAR ELIMINATES:** Equipment interaction - Equipment damage from power line spikes and surges - Errors - False printouts - Disk Skips - Audio or video hash. **FEATURES:** Inductively isolated ground - Sockets individually filter isolated - Circuit breaker protected at 15A. **VOLTAGE TRANSIENT SPIKE PROTECTION:** 2000 A peak for up to 6 Sec. duration spikes 1000A 8/20 Sec protection from repeated spikes. **LOAD HANDLING:** 1875 W max. total load; 15W per socket. **INPUT:** 125 VAC, 15 amps; standard 3-prong plug. **IBAR 3 -** Three common outlets built-in circuit breaker, pilot light, hang-up bracket and a 6-foot cord.

	List Price	Our Price
BIG0FIBAR3	Sh. Wt. 3 lbs	\$59.95 \$42.00
IBAR 46 -	Four independently isolated outlets. Built-in 15A circuit breaker, pilot light, switch, and 6-foot cord.	
BIG0FIBAR46	Sh. Wt. 4 lbs.	\$79.95 \$49.95
IBAR 88 -	8 outlets, grouped to form 4 independently isolated sets of two. Built-in 15A circuit breaker, on/off switch, pilot light.	
BIG0FIBAR88	Sh. Wt. 5 lbs.	\$84.95 \$54.95
IBAR 88M -	Eight rear-mounted outlets grouped to form four independently isolated sets of two, plus one non-isolated convenience outlet on front face 19" rack mount cabinet. Built-in 15A circuit breaker, pilot light, on/off switch, and 6-foot cord.	
BIG0FIBAR88M	Sh. Wt. 6 lbs	\$99.95 \$74.95

## RS232 Breakout Box

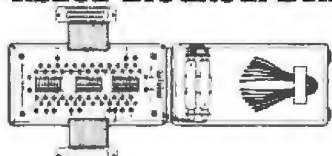

A must for every technician, repair man or systems integrator

Databox is contained in a tough, plastic case and is powered by two 1.5 volt penlight batteries. No power is consumed by the tester when not in use. Dimensions: 2.9"x5.5"x1.45" Weight: 10 oz. w/batteries. B10NW232BX \$199.00 \$158.00

**T1 SPECIAL PURCHASE GOLD 16 PIN LOW PROFILE IC. C95 SOCKETS**  
 B11G16LP package of 100 ..... \$18.00  
 B11G18LP package of 1000 ..... \$120.00  
 OEMS Stock up at this low price!!

# 38% Price Increase Next Month BUT YOU CAN BEAT IT!!

Effective with the next issue in October, BYTE is raising its advertising rates 38%. Did you know that it costs \$4300.00 to run a full page ad in BYTE? With the new rates, that cost will jump to \$5,950.00 per page\* As high as that sounds, BYTE is still the best value in the industry, both for advertisers and for readers. As BYTE's circulation continues to grow, so do the costs of paper and postage. Since 1977, BYTE's cost of paper has increased 40% and postage has increased by a whopping 175%! As you can guess, *these high advertising costs will be passed on to the public in the form of higher prices.* It will be difficult for us, or for any advertiser, to offer sale prices on special purchases or to advertise small parts in our monthly ads. For example, we could not offer the Morrow Designs DISCUS M5 at \$1495.00 under the new rates. We will, however, continue to run our six to eight pages of advertising each month because our

sales from BYTE are consistently ten times higher than from any other magazine we've advertised in. We have no plans to stop offering special sales or to stop selling small parts. On the contrary, they will continue to be featured in periodic sale flyers and in our semi-annual catalog. But to receive these catalogs and flyers you must be on our mailing list. *To get on our mailing list, all you have to do is circle the reader service number that appears at the bottom of this page on your Reader Service post card.* You will then be assured of receiving the latest information on new products, special purchases, and all-around good deals! In the mean time, look over the many specials in our nine pages of ads this month; you may never see prices like these again!

**CIRCLE NUMBER 527 ON READER SERVICE CARD**

\*Figures based on full page black & white ad; one time insertion rate. These rates may vary depending upon ad frequency and position.

## 5Mb S-100 HARD DISK SUB-SYSTEM \$1495.00 5Mb S-100 HARD DISK BACK-UP \$1100.00\*

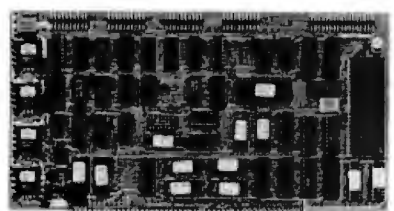

*Winchester speed, 5Mb capacity and reliability for only \$1495.00! The DISCUS M5 from Morrow Designs includes a 5Mb Seagate ST508 Winchester drive installed in a cabinet with cables and power supply, a DMA hard disk controller, CP/M® 2.2 operating system and Microsoft's BASIC programming language. Sounds to good to be true? There's more... a 5Mb add-on drive for additional storage or back-up is only \$1100.00. It's faster and more reliable than tape and costs less!*

**KEY FEATURES:**

- Storage capacity of 6.38Mb unformatted, 5Mb formatted
- Band actuator and stepper motor head positioning
- 50 megabit/second transfer rate
- Same track capacity as a double density 8 inch floppy
- 170 millisecond random average access time, reducible to 95 ms via a sample software algorithm
- The only single S-100 DMA Hard disk controller board on the market today
- Fully compatible with high speed 6MHz and 8MHz CPUs of today and tomorrow
- DMA bus arbitration as outlined by the IEEE 696 standard
- Controls 1 to 4 soft sectored Winchester drives
- ST506 or SA 1000 interface compatible
- Variable sector length (256,512,1024, or 2048 byte sectors)
- Automatic CRC generation and checking
- Addresses 1 to 16 heads
- Addresses an infinite number of tracks
- Contains its own on-board microprocessor — Signetics 8X300
- 24-bit address burst DMA transfers
- Channel driven for enhanced speed
- All disk driver routines resident on the controller
- Variable format
- No buffering required
- Maximum transfer rate 5,000,000 bits per second
- Due to this high transfer rate, a minimum CPU speed of 2.5MHz is required



The DMAHDC has been designed for expansion. One to four drives can be attached directly and controlled. One to sixteen drive heads may be addressed. Any number of tracks may be specified during the seek routine by specifying one to two hundred and fifty-six tracks one or more times. Each of the expansion abilities prepare the user to upgrade his system as technology advances to additional platters and tracks.

**DISCUS M5 WITH DMA HARD DISK CONTROLLER**  
BIMDSOMAMS Software supplied on 8" IBM3740 disk with blank I/O and INSTALL program

BIMDSOMAMS2B Software configured for Morrow DJ/2B controller and Mult I/O as console

BIMDSOMAMS50MA Software configured for Morrow DJ/DMA controller and Mult I/O as console

BIMDSOMAMS55 Software supplied on 5 1/4" soft sector (IBM/Cromemco disk w/blank I/O and INSTALL program  
BIMDSOMAMS5M Software supplied on 5 1/4" 10 sector North Star disk with blank I/O and INSTALL program  
DISCUS M5 5Mb Subsystem List Price \$2195.00

**SALE PRICE \$ 1495.00**

(order by part numbers listed above; shipping weight 17 lbs.)

**DISCUS M5 ADD-ON DRIVE**

MOSADM5 5Mb Add-On Drive List Price \$1645.00

**SALE PRICE \$ 1100.00\***

\*With purchase of above M5 subsystem or with previous purchase of M5 subsystem from Priority One Electronics. Proof of prior M5 purchase required with order.

**CIRCLE OUR READER SERVICE NUMBER!!**



**PRIORITY ONE ELECTRONICS**



9161 DEERING AVE • CHATSWORTH, CA 91311

**ORDER TOLL FREE (800) 423-5922 - CA, AK, HI CALL (213) 709-5464**

Terms: U.S. VISA, MC, BAC, Check, Money Order, U.S. Funds Only. CA residents add 6 1/2% Sales Tax. MINIMUM PREPAID ORDER \$15.00. Include MINIMUM SHIPPING & HANDLING of \$3.00 for the first 3 lbs. plus 40¢ for each additional pound. Orders over 50 lbs. sent freight collect. Just in case, please include your phone number. Prices subject to change without notice. We will do our best to maintain prices through September, 1982. Credit Card orders will be charged appropriate freight. If you haven't received your Spring '82 Engineering Selection Guide, send \$1.00 for your copy today! Sale prices are for prepaid orders only.

Circle 527 on Inquiry card.

# Unclassified Ads

**FOR SALE:** Original IMSAI 8080 S-100 mainframe, processor board, front panel 20-A supply, 12K RAM, 4-port parallel I/O, 22-slot motherboard, universal cassette interface, extender board, Cromemco color TV Dazzler, Polymorphic Systems black-and-white TV interface, Wameco EPROM board, Smith KBD-3 encoded keyboard, RF modulator, complete documentation of all boards and 8080 manuals, and software on paper tape for 8080 and Dazzler. Will accept best offer. Roger French, 1170 Parkview Dr., Manon, IA 52302, [319] 377-6255.

**FOR SALE:** BYTE #1: \$10 or best offer. Keyboard Microcomputing #1, 2, 3, 4, 5: \$5 or best offer each. Clive Frazier, POB 972, Windemere, FL 32786

**FOR SALE:** Teletype Model 43 30-cps dot-matrix printer terminal, RS-232 interface, pin feed, and Hall-effect keyboard. In good condition. \$800 or best offer. Richard Rostrum, 7344 North Hoyne, Chicago, IL 60645, [312] 973-5064 evenings, 927-5510 days.

**WANTED:** FORTRAN compiler or interpreter for Apple II Plus to be used in teaching introductory course. Limited language subset acceptable and graphics ability desirable. Institutional license required. Avery Catlin, POB 3726, Charlottesville, VA 22903, [804] 924-3337.

**WANTED:** Info Terminal Communications of Raleigh, North Carolina. Video Terminal Model TC275. D. Boone, POB 330, Valley Mills, TX 76689.

**FOR SALE:** 48K Apple II with two disk drives and manuals. Xerox 1730 printer and tractor feed. Virtually brand new. Best offer over \$4500. F. O'Neill, 154 East 46th St., New York, NY 10017, [212] 599-5845

**FOR SALE:** Sanyo 9-inch monitor in excellent condition. Best offer takes it. I will pay first-class shipping and insurance. Chuck Miller, 7th USAAD, APO NY 09169.

**WANTED:** Old-style Memory Plus circuit board manufactured by the Computerst. This board contains 8K bytes of 2102-type RAM and sockets for EPROMs. It was made for the AIM/SYMAKIM type microcomputer. Jerry Stoker, 8325 Kirm Dr. NE, Albuquerque, NM 87109, [505] 821-3354.

**FOR SALE:** North Star Horizon computer with 32K, two quad-density floppy-disk drives, two serial and one parallel ports, North Star DOS and BASIC (factory assembled), \$2100. Inertube terminal with printer port, graphics, and full keyboard with numeric pad. \$500. Centronics 103 printer with bidirectional dot matrix, 132-column tractor feed, two character sizes, 165 cps, and RS-232C interface. \$400. All in excellent condition with manuals. All offers considered. Bill Novak, 12 Mechanicsville Rd., Granby, CT 06035, [203] 529-2550 8-4 ET.

**FOR SALE:** Microace computer with 8K ROM and 2K RAM options, assembled and tested, for \$125. Price includes shipping. Postal money order only please. David M. Hofmann, 389A Dyer Dr., FPO San Francisco 96630.

**FOR SALE:** S. D. System S-100 boards. SBC-100, Expandoram I 64K, and Versafloppy II disk controller. \$250 each or \$700 for all three. Also have an Altair 680B 6800 microcomputer with 16K static RAM \$150 each for microcomputer or 16K RAM board: \$275 for both. E. Cummins, 5124 Walden Mill Dr., Norcross, GA 30092, [404] 447-9060.

**WANTED:** Apple II (48K) with Autostart ROM, Applesoft card, compatible disk drive and controller (preferably Apple), black-and-white 13-inch monitor, joysticks, and compatible printer. All must be in good to excellent condition. Items may be separate from different individuals. Send model year, purchase price, and asking price. Bob Koskovich, Organization COMPU, 125 East Hermosa Dr., San Gabriel, CA 91775.

**FOR SALE:** Surplus electronic components: resistors, capacitors, transistors, crystals, switches, LEDs, panels, knobs, potentiometers, PC boards, diodes, rectifiers, etc. Also have about 150 ICs and 40-pin unidentified Intel chip. Will sell any or all for 25% of list. Please write or call as soon as possible. Steve Riley, 30 Kim Court W, Westerville, OH 43081, [614] 891-4986 or Phillip Drayer, 6342 Freeman Rd., Westerville, OH 43081, [614] 882-4930.

**FOR SALE:** Processor Technology SOL-20 with 48K RAM, Helios II dual 8-inch disk system, 12-inch monochrome video monitor, Digital Equipment LA-180 DECprinter I with serial interface, PTSDOS Version 1.5 disk operating system, Extended Disk BASIC and FORTRAN, and instruction manuals. \$4000 without DECprinter. \$6000 with DECprinter Patrick J Edwards, 1600 West Crosby, Stton, TX 79364.

**GERMANY:** Computer hobbyist (6800, W/H-89, S-100) seeks friends near Frankfurt with interest in hardware/software and local/remote networks. Also have lots of hardware to swap and sell. 8-inch floppy-disk drives, modems, VDUs, hard disks, 9-track tape drives, card reader, keyboards, monitors, character- and line-printers, scopes, and more. I am looking for a letter-quality printer and old EDP stuff like core memories, type elements, pdcs, hammer modules, hard-wired ROMs, etc. Defects are okay. Also looking for programs: games, utilities, data management, etc., for Heath H-89 (CP/M+HDOS), S- and 8-inch. Rolf Petersen, 06003-7455 evenings and weekends.

**WANTED:** Student experimenter just starting in computers desperately seeking advice how to implement KIM/SYM-I microcomputers for robotics use. All replies will be greatly appreciated. Brian Jacoby, RR 1, Box 157, Vesta, MN 56292.

**FOR SALE:** MITS Altair 8800b mainframe, dual double-density Shugart SA-400 drives, 38K of static RAM, quad parallel ports, triple serial ports, Heathkit H-19 smart video terminal, Heathkit H-14 smart line printer, CP/M 2.0, North Star 5.0 DOS/Monitor/BASIC, and miscellaneous hardware/software. Fully integrated, functional, with all documentation. \$3500 (package only). G. Godden, 18401 67th West, Lynnwood, WA 98036, (206) 776-6124.

**FOR SALE:** Godbout S-100 desktop computer enclosure with Godbout 20-slot motherboard and CVT power supply. Bought new last summer. Never used. Will accept reasonable offer. S. Dimitroulias, 191 Hempstead St., New London, CT 06320, (203) 443-1398 (no collect calls).

**FOR SALE:** First two years of BYTE: \$120 or best offer. First three years of Klobaud Microcomputing: \$108 or best offer. First seven Bug Books, one through five: \$35. All in like-new condition. L. Chambers, 4530 Sheridan St., Davenport, IA 52806.

**WANTED:** LNW-80 owners to write me. User group interests; possible software exchange. Interests are high-resolution graphics, animation, cartooning, A-D-A, and music. Don Ball, POB 72, Saline, MI 48176.

**FOR SALE:** PET stuff: IEEE-488 auto answer/originate modem TNW-103; \$150. PET to S-100 interface, supports DMA Inc. Dazzler; \$100. S-100 box, 22-slot bus, and power supply; \$75. Two S-100 BK memory boards; \$75 each. Dazzler color graphics board, \$100. Everything for \$400. Larry Shaw, 215 Hazel Ave., Mill Valley, CA 94941, [415] 383-1092.

**FOR SALE:** 24K Atan 800 with 810 disk. DOS 1 plus extra disk in three-ring binder with vinyl disk holders, BASIC, Super Breakout, and Star Raider cartridges, RF adapter, two joysticks, and set of paddles. All support documentation plus Atari's newsletters \$1300 or best offer. Cliff Fuhrmann, 1833 35th St. NW, Rochester, MN 55901, [507] 286-1842.

**FOR SALE:** HP-9815 with RS-233 option. Has the diagnostic tapes with an extra tape for personal use. Totally operational with very small amount of operating time on it. Approximately four years old. \$1000. Richard Grancorvitz, Norland Corporation, Rte. #4, Norland Dr., Fort Atkinson, WI 53538, [414] 563-8456 or 563-9145.

**FOR SALE:** Ohio Scientific C3A with 48K, OS65U operating system, and two Siemens disk drives. Also, Intel SDK-51 8051 microcomputer development tool, assembled and working. Best offers. Neal Erzenauer, 2180 Old Hwy. 8, St. Paul, MN 55112, [612] 780-4880.

**FOR SALE:** TRS-80 accessories. Percom data separator, \$15. Percom Doubler I with documentation and DBLDS without double-density disk chip; \$30. Double Zap II, double-density patch for NEWDOS/80 V1 with documentation and original disk; \$20. Radio Shack Modem I, 300 bps/originate only/acoustic coupler; \$75. All items guaranteed working/postpaid. Kerry Chesbro, 13605 115th Ave. NE, Kirkland, WA 98033, (206) 821-2042 evenings.

**FOR SALE:** S-100 hardware. Integrand 800D desktop mainframe with 15 connectors, eight RS-232 cutouts, and 15-A power supply; \$300. SD Expandoram I with 16K 4116 RAM, 2 MHz; \$200. SSM VBI-B 64 by 16 video board; \$150. SSM PB-1 2708/2716 PROM programmer; \$150. Jade P/S I/O with one parallel port and two serial ports (one is cassette); \$100. Must sell, prices negotiable. Douglas Zimmerman, 2824 St. Paul St., Baltimore, MD 21218, [301] 889-1698.

**FOR SALE:** Three Okidata Model CP110 bidirectional 5 by 7 dot-matrix printers. Parallel I/O, 110 cpi, 70 lpm, 80-character buffer, frictionfeed, 80-column, 6-bit ASCII code, uppercase, and punctuation. Roll paper or single sheet. \$300 each. Danny Kile, 534 Elden Ave. NW, Roanoke, VA 24019, [703] 366-4480.

**FOR SALE:** Super E# 1802 computer. Fully expandable S-100 computer. Excellent starter system. Includes Lo Address option and standard case. Full documentation. Three months old, in good condition. Call for more information. \$100 or best offer. Alex Segal, 17 Fox Run Rd., Bedford, MA 01730, [617] 275-7534.

**WANTED:** SwTPC computer, disk, and cassette I/O. Send description and phone number. Kearney Hill, 1027 Whitner, Emporia, KS 66801, [316] 343-1915.

**WANTED:** 48K Apple II with autostart ROM. One disk drive with a 3.3 controller card. A black-and-white or color monitor, or an RF modulator. For a 15-year-old paying for it himself (so unfortunately it would have to be paid for a little at a time on an unmet payment basis until I can get a job this year). Kerwin Thomas, 1528 Kinsdale St., Philadelphia, PA 19126, [215] 224-8645.

**FOR SALE:** 22-slot motherboard from QT Systems installed in Vector CCK-100 card cage; \$180. Eight new and two used Vector prototyping boards (8800V) for \$13 each. Also, integrated circuits in limited quantities: 20 74LS670s and 25 74LS645-1s for \$2 piece. All prices do not include postage. Jack C. Garden, POB 1317, Lake Dallas, TX 75065, [817] 497-2083.

**FOR SALE:** 16K static RAM board; \$150. Vector Graphic 2K EPROM, 1K RAM board, \$75. Heunscn Speechlab with microphone; \$100. All works well. Richard DeMayo, 7852 Bartholomew Dr. NE, North Ft. Myers, FL 33903, [813] 997-3047.

**FOR SALE:** Radio Shack Model 1, Level 2 with 16K (\$849). With 16K expansion interface (\$499), two mini-disk drives (\$1000), Base 2 Inc. Model 800 printer (\$649), desk for equipment (\$50), Visicalc (\$100), one Budget Management (\$24.95), Standard & Poor's Stockpak system (\$49.95). Used only six months. Cost \$2520; make offer. Walter H. Niles, 101 Country Ridge Dr., Port Chester, NY 10573.

**UNCLASSIFIED POLICY:** Readers who are soliciting or giving advice, or who have equipment to buy, sell or swap should send in a clearly typed notice to that effect. To be considered for publication, an advertisement must be clearly noncommercial, typed double spaced on plain white paper, contain 75 words or less, and include complete name and address information.

These notices are free of charge and will be printed one time only on a space available basis. Notices can be accepted from individuals or bona fide computer users clubs only. We can engage in no correspondence on these and your confirmation of placement is appearance in an issue of BYTE.

Please note that it may take three or four months for an ad to appear in the magazine.

# Unclassified Ads

**WANTED AND FOR SALE:** I need a single-density mini-floppy for the North Star Horizon. For sale or trade, ASR33 Teletype with paper-punch unit. Ron Magazzu, 126 Highfield Lane, Nutley, NJ 07110

**FOR SALE:** OSI CIP (Model I) software. Programs include fast arcade games, utilities, and tiny compiler etc. from Aardvark. They are on original cassette tapes complete with all instruction/documentation. Total cost of the 12 programs was \$150; will sell for \$75. Joseph Liu, 808 West 2nd Ave, #2, Chico, CA 95926. (916) 893-4310

**WANTED:** Goodwill. Student without pride or money looking for handouts. I am desperate for a start in electronics and computers. I need used, surplus, out-of-date, or damaged equipment (circuit boards, terminals, printers, computers, TVs, radios, any electrical or mechanical parts), documentation, schematics, magazines, etc. Write or call me and I will make the shipping arrangements. Scott A. Jones, 8095 North Meridian St., Indianapolis, IN 46260. (317) 251-6499 evenings

**WANTED:** I live in a remote area of Michigan and own a TRS-80 Model II. I would like to correspond with other TRS-80 Model II owners. James R. Young, POB 336, Ludington, MI 49431

**WANTED:** Young, poor, but talented independent software developer (recent computer-science graduate) looking for wonderfully cheap microcomputer hardware and software to work with and build on. Send offer with full description. Jim Talley, 929 Dumaine St., #5, New Orleans, LA 70116.

**FOR SALE:** 1200 bps modem (Anderson Jacobson ADAC 1200). Operates either acoustically coupled or directly connected. Documentation included. \$275. Tom Alexander, 333 A St. NE, Washington, DC 20002. (202) 547-0355.

**FOR SALE:** Hewlett-Packard HP-85 computer. Please mail your best offer, name, and telephone number. You can pick it up in New York City or receive it by mail. Dr Gregory M. Hunter, 35 Stevens St., Danbury, CT 06810

**FOR SALE:** Digital Group 280 Bytemaster fully integrated computer with 64K dynamic memory, detachable keyboard, built-in monitor, and single-density 5¼-inch disk drive. Prewired for up to four 5¼- or 8-inch disk drives and for a parallel port to printer. Very expandable. Excellent condition. DISKMON, BASIC, assembler, and disassembler. Full documentation and two boxes of disks. Best offer over \$1500. Brent Dowd, 5289 South Manitou Rd., Littleton, CO 80123. (303) 797-7512.

**FOR SALE:** Carterphone Selectric terminal with Worldwide ASCII conversion. Mechanically okay, but has some electronic glitches (will not execute ASCII carriage return consistently from Apple II; shift key occasionally hangs keyboard). Sold as is. First certified check or money order for \$350 gets it; will ship freight collect. Herb Rand, POB 136, Sweet Bnar, VA 24595

**FOR SALE:** Digital Group 32K dynamic-memory board; \$225. I/O parallel board; \$25. Video interface (64 by 16) and audio interface; \$75. Motherboard with some connectors; \$20. Two Phi-Decks and controller; \$200. 280 processor board; \$50. Phi-Deck and audio software; \$50. Also, 12A-5V ovp power supply; \$75. Jeff Ryder, 1983 McKelvey Hill Dr. Apt. E. St. Louis, MO 63043. (314) 878-6620 after 6 p.m.

**FOR SALE:** TRS-80 Model I, Level II with 16K, cassette recorder, and instruction manuals. Best offer. G. Zaybal, 5810 Buck Court, Westmont, IL 60559. (312) 387-5934 days, 964-1551 after 5 p.m.

**FOR SALE:** Intel 8086 microprocessor chips at one-third the normal price. 16-bit, prime, and unused. I have 10 of these left over from a project. \$30 each. Programmers' manuals: \$4 each. Bob Rockinson, RD #1 Maiden Rd., Coal Center, PA 15423. (412) 938-7050.

**WANTED:** Could anybody send me a copy of the three-part article "APL Interpreter for Microcomputers" (BYTE August, September, and October 1977 and corrections in November and December 1977) and information about building APL interpreters in general (especially for the 6502)? This is a cry for help because in Austria I won't get any support of this kind! Wolfgang Niesch, Pacassstr. 28, A-1130 Vienna, Austria

**FOR SALE:** IMSAI 8080 microprocessor complete with front panel, case, power supply, 22-slot motherboard with 14 edge connectors already soldered, IMSAI MPU B processor board, and MITS 4K RAM. Fully burned-in and tested. Complete with original documentation and manuals. Never used, hence, in brand-new condition. Best offer/\$500. Peter Kaezopoliski, 8200 Boulevard East, North Bergen, NJ 07047. (201) 869-8448 evenings.

**FOR SALE OR SWAP:** TRS-80 Color Computer program packs: Quasar Command, Project Nebula, Sking, Chess, Bustout, Music, Pinball, Personal Finance, and Color File. Plus on tape: Pyramid (adventure), Quest (semiadventure), and Star Trek (game). Original price \$335. Will sell for \$167.50. All new in original boxes. Will send C.O.D. (or send check or your listing) Bland's Nursery c/o Shane Bland, Hwy 54 West R.R. 3, Linton, IN 47441. (812) 847-9427.

## BOMB

### BYTE's Ongoing Monitor Box

Article #	Page	Article	Author(s)
1	24	Quinti-Maze	Tsuk
2	34	Three Dee Tee	Stuart
3	54	The Epson QX-10/Valdocs System	Williams
4	64	Build the Microvox Text-to-Speech Synthesizer, Part I: Hardware	Ciarcia
5	92	The Apple III and Its New Profile	Moore
6	136	Computers Can Play a Dual Role for Disabled Individuals	Vanderhelden
7	166	A New Horizon for Nonvocal Communication Devices	Demasco,
8	186	Minspeak	Foulds
9	204	The FDA Regulation of Computerized Medical Devices	Baker
10	218	Talking Terminals	Jorgens,
11	231	The Cognivox VIO-1003: Voice Recognition and Output for the Apple II	Bruch,
12	240	The Abilityphone	Houston
13	250	Braille Writing in Pascal	Stoffel
14	276	Adaptive-Firmware Card for the Apple II	Murray
15	318	User's Column: Letters, Pascal, CB/80, and Cardfile	Rush
16	342	Logo: An Approach to Educating Disabled Children	Fant
17	398	Model III A to D Revisited	Schwejda,
18	420	The Case of the Purloined Object Code: Can It Be Solved? Part I: The Problems	Vanderhelden
19	440	A Comparison of Five Compilers for Apple BASIC	Pournelle
20	466	Digital Troubleshooting with Signature Analysis	Weir,
21	476	Program Your Own Text Editor, Part I: Avoid Complex Commands by Using Instant Updating	Russell,
22	513	A Weaving Simulator	Valente
23	520	Turn Your Apple II Into a Storage Oscilloscope	Barden
24	531	Pickles & Trout CP/M for the TRS-80 Model II	Stern
25	537	TRS-80 Disk Editor/Assemblers	Taylor,
			Taylor
			Plubeni
			Fobes
			Helser
			Korba
			Smith
			Danelluk

### BASIC Wins BOMB

Our congratulations to Thomas E. Kurtz for his article "On the Way to Standard BASIC," which captured first place in the June BOMB results. The first-place prize of \$100 is on its way to the author. A very close second place goes to Rod Daynes for "The Videodisc Interfacing Primer," a concise guide to developing your own interactive videodisc programs. Rod will receive the second-place award of \$50. Jerry Pournelle's User's Column and Steve Leibson's Input/Output Primer, Part 5: Character Codes share the honors for third place.



# Reader Service

Inquiry No.	Page No.	Inquiry No.	Page No.	Inquiry No.	Page No.	Inquiry No.	Page No.
1	47th STREET PHOTO 374	530	CHIPS & DALE 394	168	DOKAY COMP.PROD.INC. 567	253	JDR MICRODEVICES 580, 581
2	800 SOFTWARE 197	85	CHRISLIN INDUSTRIES 441	169	DRAKE, R.L. CO. 471	254	JDR MICRODEVICES 582, 583
3	A.S.T.RESEARCH 151	86	CMC,INTL 205	170	DREAM ELECTRONICS 560	255	JDR MICRODEVICES 584, 585
4	AB COMPUTERS 555	87	CMC,INTL 377	171	DUAL SYS.CONTROL CORP. 82	256	KADAK PRODUCTS 443
5	ABM PRODUCTS 365	88	COGITATE 566	172	DYMARC IND. 505	257	KERN PUBLISHING 340
6	ABW CORP. 542	89	COLONIAL DATA SERV. 140	173	DYSAN CORP. 360, 361	258	KERN PUBLISHING 341
509	ADAVISION INC. 534	90	COLUMBIA MICROSYS.INC. 324	174	E.T.S. CENTER 496	259	KIAI SYSTEMS 211
9	ADDMASTER CORP. 568	91	COLUMBIA NATIONAL 419	176	ECONOMY PERIPHERALS 556	260	KROWN COMPUTING 566
10	ADV.COMP.PROD. 574, 575	93	COMMODORE BUSN.MACH. 258, 259	177	ECOSOFT 507	261	LABORATORY COMP.SYS. 407
11	ADV. DIGITAL PROD. 560	94	COMMUNICAL INC. 511	178	EDGE MICROSYSTEMS 478	262	LABORATORY MICROSYS. 558
12	ADV.MICRO DIGITAL CORP. 273	95	COMMUNICATION CABLE 560	179	EDMUND SCIENTIFIC CO. 493	264	LEADING EDGE PROD CIII
13	ADV.SYS.CONCEPTS 560	96	COMMUNICATIONS ELECTR. 571	180	EDUCATIONAL MICROCOMP. 379	265	LEGEND INDUSTRIES 253
15	AEGIS SYSTEMS 154	97	COMMUNICATION RESEARCH CORP. 86	181	ELCOMP PUBLISHING INC. 400	266	LIFEBOAT ASSOC. 181
511	AFTERTHOUGHT ENG. 458	98	COMPONENTS EXPRESS 465	182	ELECTROLABS 573	267	LIFEBOAT ASSOC. 499
16	ALABAMA DEVELPMT. OFFICE 233	99	COMPUADD 564	513	ELECTRONIC CONTROL 535	268	LINK FLIGHT SIMULATION 460
*	ALF PRODUCTS, INC. 130	100	COMPULINK CORP. 45	183	ELECTRONIC SPCUSTS. 514	269	LNW RESEARCH 147
515	ALIEN GROUP 459	101	COMPUPROG/GODBOU 184, 185	184	ELECTRONIC SYS.FURN. 524	269	LOGICAL DEVICES 504
17	ALPHA BYTE COMP.PROD. 52, 53	102	COMPUSERVE 93	185	ELLIS COMPUTING 388	270	LOMAS DATA PRODUCTS 230
18	ALPHA BYTE COMP.PROD. 359	383	COMPUSHACK 435	186	EMERGING TECH.CONSLT. 507	272	LYBEN COMP.SYS. 407
19	ALPHA SOFTWARE 19	517	COMPUTER AGE 541	*	EMPIRICAL RESRCH. GRP. 94	273	LYBEN COMP.SYS. 558
20	ALSPA COMP.SYS. 173	104	COMPUTER CHANNEL 268	188	ENERCOMP 339	274	LYBEN COMP.SYS. 564
21	ALTOS COMP.SYS. 280, 281	105	COMPUTER DYNAMICS 478	189	ENTERCOMP 478	275	LYBEN COMP.SYS. 568
22	AMDEK CORP. 73	505	COMPUTER ENTREPRENEUR 451	190	ENTEX INDUSTRIES 468	276	LYBEN COMP.SYS. 572
23	AMER.SMALL BUSN.COMP. 397	106	COMPUTER EXCHANGE 284, 285	190	ENVIRONMENTAL CONTROL SYS. 385	277	MACROTECH COMP.PROD. 303
24	AMER.SQUARE COMP. 308, 309	107	COMPUTER FURN. & ACCSS. 452	191	EPSON AMERICA 129	278	MACROTECH INT'L. 183
25	ANADEX 143	108	COMPUTER GRAPHICS WORLD 384 A & B	192	EPSON AMERICA 332, 333	279	MAGNOLIA MICROSYS. 572
26	ANCIE LABS 367	109	COMPUTER INNOVATIONS 465	193	ESSEX PUBLISHING 473	280	MAILCOMP INC. 429
27	ANDERSON JACOBSON 278	110	COMP. LEARNING TREE 188	194	EVOLUTIONARY ELECTR.INC. 465	281	MANCHESTER EQUIPMENT 475
28	ANN ARBOR TERMINALS 243	112	COMPUTER MAIL ORDER 228, 229	195	EXPOTEK 46	282	MARCEY,INC. 399
29	ANTEX DATA SYS. 104	113	COMPUTER PARTS EXCH. 484	196	F.T.G.DATA SERV. 558	283	MARYMAC INDUSTRIES 291
30	APPARAT INC. 328, 329	114	COMPUTER PLUS 244	197	FLOPPY DISK SERV.INC. 315	285	MAXELL DATA PRODUCTS 51
31	APPLEWARE,INC. 556	115	COMPUTER RESOURCES 467	198	FORMULA INT'L. 437	287	MAXTEK 508
14	APPLIED BUSN. CONCEPTS 562	116	COMPUTER SHOPPER 396	507	FOURTH DIMENSION 157	287	MBP SFTW. & SYS.TECH. 457
*	APPLIED CREATIVE TECH. 491	117	COMPUTER SHOPPER 566	200	FREDERICK COMP.PROD. 533	288	MC NEILL 469
32	ARBA 40	118	COMPUTER SPLCLTES. 300, 301	202	FRANKLIN COMP.CORP. 164, 165	289	MCGRRAW-HILL BOOK STORE 392
33	ARCHIVE 219	119	COMPUTER TOOLBOX,INC. 560	534	FRONTIER TECH. CORP. 44	290	MCILLAN BOOK CLUBS 432, 433
34	ARTIFICIAL INT'L.RESRCH. 407	120	COMPUTER WRHSE. 321	201	FUJITA,RICHARD & ASSOC. 556	292	MEDIA DISTRIBUTING 373
35	ASAP COMP.PROD.INC. 67	121	COMPUTERS WHOLESALE 271	202	G & G ENGINEERING 331	292	MEMOREX MEDIA PROD. 179
36	ASAP COMP.PROD.INC. 382	122	COMPUTERTIME INC. 492	*	G&M SYSTEMS 283	293	MEMORY MERCHAND 85
37	ASC ASSOCIATES 556	123	COMPUTERWORLD INT'L 338	203	G-H COMPUTER SYS. 564	506	MERIDIAN 428
38	ASC COMP.SYS. 535	124	COMPUTERWORLD INT'L 384	205	GENERAL SOFTWARE INC. 196	296	METASOFT CORP 159
39	ASHTON-TATE 216, 217	125	COMPUVIEW PROD.INC. 68, 69	206	GENSTAR REI SALES CO. 16	296	METASOFT CORP 159
*	ASPEN SFTW.CO. 42	126	CONCORD COMP.PROD. 312	207	GILTRONIX,INC. 556	297	MFJ ENTERPRISES INC 142
40	ATARI 111	127	CONCURRENT CORP. 314	208	GLADSTONE ELEC. 564	297	MICRO AGE COMP.STORE 107
41	ATLANTIC CABINET CORP. 556	128	CONSUMER COMP. 236, 237	208	GNOSIS 489	298	MICRO BASICS 562
42	AUDEC CORP. 564	129	CONTEXT MANGMNT.SYS. 8	210	H&E COMPUTRONICS 393	298	MICRO BUSINESS WORLD 353
43	AUTOMATED EQUIPMNT. 350	130	CONTEXT MANGMNT.SYS. 9	211	H.E.I., INC. 376	300	MICRO COM 235
*	AUTOMATED PRGRM. METHODS 570	131	CONTINENTAL RESOURCES 562	212	HALDO PRODUCTS 560	111	MICRO COMP.SERV.CNTR. 495
44	AUTOMATED BUSN.MACH. 299	132	CONTROL C SOFTWARE 102	213	HAYES MICROCOMP.PROD. 207	420	MICRO CONTROL SYS 313
45	AVOCET 485	133	CONTROL DATA 215	532	HAYES MICROCOMP.PROD. 146	301	MICRO DATA-TEK 498
46	B&B ELECTR. 570	134	COSMIC COMP.UNLTD. 568	214	HEATH COMPANY 97	302	MICRO DEVELOPMENTS 464
47	BADGE-A-MINIT 473	271	COST PLUS COMP 568	216	HEWLETT-PACKARD 190, 191	303	MICRO MAGAZINE 302
48	BAUSCH & LOMB INSTR.SYS. 141	135	CPU SHOP, THE 559	217	HEWLETT-PACKARD 190, 191	304	MICRO MANAGEMENT SYS. 28
49	BAUSCH & LOMB INSTR.SYS. 141	136	CREATIVITY UNLTD. 407	218	HEWLETT-PACKARD 190, 191	305	MICRO MATCH 475
50	BAY TECHNICAL ASSOC. 510	137	CROMEMCO CII, 1	219	HEWLETT-PACKARD 190, 191	306	MICRO MIDWEST 286
*	BELL, JOHN ENGR. 557	138	CROMEMCO 2	220	HEWLETT-PACKARD 190, 191	246	MICRO MINT 572
51	BINARY CORP. 492	139	CUSTOM COMP.SYS. 378	*	HILTON HOTEL CORP. 319	310	MICRO MINT 529
52	BISON PRODUCTS 327	516	CUSTOM COMP.TECH. 506	221	HOURLASS SYSTEMS 404	311	MICRO PRO INT'L 279
53	BISON PRODUCTS 327	*	CYBERNETICS INC. 131	222	HOURLASS SYSTEMS 405	111	MICRO SCI 239
54	BISON PRODUCTS 327	140	D & W DIGITAL 487	223	HYPERTEK, INC. 416	312	MICRO SCI 467
55	BISON PRODUCTS 327	142	DATA ACCESS CORP. 287	224	HYTOR, INC. 570	313	MICRO TECHNOLOGY 478
56	BISON PRODUCTS 327	143	DATA EXCHANGE 492	225	I.B.C. 37	*	MICRO WEST 30
57	BLACKBEARD ASSOC. 560	522	DATA-MAIL 448	539	I.C.R. FUTURESOF 387	314	MICRO WORKS, THE 473
58	BLAISE COMPUTING INC. 407	144	DATA MANAGEMENT SYS. 568	226	I.O. SYSTEMS 177	286	MICROCOMP.BUSN.INC. 149
59	BLAT RESRCH. & DEVELP. 471	145	DATA SOURCE SYS.CORP. 304	227	I/O TECHNOLOGY 195	316	MICRODYNAMICS 558
*	BOTTOM LINE, THE 238	146	DATA TECH INDUSTRIES 81	228	IBM 118, 117	*	MICROHOUSE 12, 13
62	BOWER-STEWART 558	147	DATA-ED 14	229	IMPERIAL MICRO SUPPLY 570	317	MICROMAIL 124
63	BRIDGE COMPUTER 222	148	DATA-RITE INDUSTRIES 417	230	INDEPENDENT BUS.SYS. 241	318	MICROPERIPH.CORP,THE 566
64	BRIDGE COMPUTER 568	149	DATABIT INC. 460	518	INFO. RESOURCES 541	541	MICROSOFT 15
65	BRIDGE COMPUTER 324	148	DATAFACE 306	232	INNOVATIVE MEASUREMNTS. 310	542	MICROSOFT 145
66	BROKERSOFT INC. 570	149	DATASOUTH COMP.CORP. 75	233	INNOVATIVE SOFTWARE 439	319	MICROSOFT 344, 345
67	BYTE BOOKS 160, 161	150	DATASOUTH COMP.CORP. 210	234	INSTITUTE -SCITF.ANALYSIS 588	320	MICROSOFT 295
68	BYTE BOOKS 343	151	DATAWARE,INC. 564	235	INT'L.MICRO SYS. 290	321	MICROTECH 263
70	BYTE BOOKS 380, 381	141	DAVONG SYS.INC. 395	236	INTERCONTL MICRO SYS 356, 357	322	MICROTECH EXPORTS 438
71	BYTE BOOKS 483	152	DAY STAR TECHNOLOGY 49	237	INTEGRAL DATA SYS. 453	323	MIKOS 474
504	BYTE BOOKS 483	153	DEALIN' ELECTR. 558	238	INTEGRAND 522	324	MILLER MICROCOMP.SERV. 462
*	BYTE BACK ISSUES 390	154	DECISION RESOURCES 87	239	INTEL CORP 208, 209	325	MINI MICRO MART 269
*	BYTE PUBL. INC. 514	155	DENNISON KYBE CORP. 155	240	INTELLIGENT ARTEFACTS 448	326	MINI MICRO MART 569
72	BYTEK COMP. SYS. 262	156	DESTEK GROUP,THE 264, 265	242	INTERACTIVE MICROWRE. 509	327	MONARCHY ENG.INC. 566
73	BYTEWRITER 20	157	DIGITAL EQUIPMNT.CORP. 90, 91	243	INTERACTIVE STRUCT. 122	328	MORROW DESIGNS 296, 297
74	C-SYSTEMS 564	160	DIGITAL EQUIPMNT.CORP. 336, 337	241	INTERBUSINESS CORP. 570	330	MOUNTAIN VIEW PRESS 203
75	CALIF. DATA CORP. 556	161	DIGITAL MARKETING 6	243	INTERSTATE TELEPHONE CO. 158	331	MTI SYSTEMS CORP. 525
*	CALIF. DIGITAL 566, 587	78	DIGITAL MEDIA 562	244	INTERTEC DATA SYS. 41	332	MULTITECH ELECTR.INC. 287
*	CALIF.MICRO COMP. 364	162	DIGITAL MICROSYSTEMS 105	245	INTERTEC DATA SYS. 43	333	MUSYS 450
76	CALTA COMP.SYS.LTD. 564	163	DIGITAL PRESS 371	247	IPEX INT'L. 570	334	NAT'L.DATA SUPPLIES 26
78	CDR SYSTEMS 478	164	DIGITAL RESEARCH 29	248	ISOTECH, INC. 132	335	NAT'L.INTEGRATED SFTW. 120
79	CENTENNIAL SOFTWARE 320	165	DIGITAL RESRCH. COMP. 576, 577	249	J.C.SYSTEMS 503	336	NAT'L.SOFTWARE SYS. 252
81	CENTRE COMP.CONSTNTS. 566	166	DISCOUNT SOFTWARE 368, 369	250	JADE COMP.PROD. 592, 593	337	NEBS 497
82	CER-TEK INC 562	167	DISTRIBUTED COMP.TECH 560	251	JADE COMP.PROD. 594, 595	338	NEC HOME ELECTR.USA 115
83	CHAPIN ASSOCIATES 558			252	JAMECO ELECTR. 590, 591	339	NEC INFORMATION SYS. 11
536	CHECKMATE 539					340	NEC INFORMATION SYS, 163
537	CHECKMATE 539					341	NEECO 403
540	CHECKMATE 568					342	NETRONICS 479
84	CHECKS-TO-GO 18					343	NETRONICS 561

To get further information on the products advertised in BYTE, fill out the reader service card with your name and address. Then circle the appropriate numbers for the advertisers you select from the list. Add a 20-cent stamp to the card, then drop it in the mail. Not only do you gain information, but our advertisers are encouraged to use the marketplace provided by BYTE. This helps us bring you a bigger BYTE. The index is provided as an additional service by the publisher, who assumes no liability for errors or omissions. \*Correspond directly with company.

# Reader Service

Inquiry No.	Page No.	Inquiry No.	Page No.	Inquiry No.	Page No.	Inquiry No.	Page No.
355	DRYX SOFTWARE 148	391	QUARK ENGINEERING 21	428	SLUDER 496	462	THUNDERWARE 127
	OSBORNE COMPUTERS 31	392	QUASAR COMPANY 223	429	SOFTWAREHOUSE,THE 409	464	TNW CORP. 262
	OWENS ASSOC. 138, 139	494	QUBIE DIST. 389	430	SOFTWARE STORE 562	465	TRANSNET CORP. 503
510	PACIFIC COMPUTER 456	394	QUCES 212, 213	431	SOFTWEST PROD. 407	499	TRATEC 298
356	PACIFIC EXCHANGES 324, 478, 556, 562, 566, 570	395	QUENTIN RESEARCH INC. 425		SOLID STATE SALES 519	466	TRISTAR DATA SYS. 430
362	PALOMAR COMP.EQUIP. 578, 579	396	QUEST ELECTR. 563	432	SONICS MICRO SYS. 121	467	TSK ELECTR.CORP. 189
363	PAN AMERICAN ELEC INC. 477	397	QUEST RESEARCH INC. 564	433	SOUTHERN COMP.SYS. 226	468	U.S. MICRO SALES 568, 589
364	PANASONIC 100, 101	398	QUICK TAX 72	525	SPECTRA MARKETING 459	469	US ROBOTICS 38
365	PC' 330	399	QUME CORP. 27	434	SSM MICRO COMP. PROD. 388	470	UNISOURCE ELECTR.INC 512
366	PC MAGAZINE 247	401	R.R. SOFTWARE 335	435	STACKWORKS 467	471	VANDATA 156
367	PEACHTREE SOFTWARE 152, 153		R.T.I. RESEARCH TECH. 411	436	STANDARD SFTW.CORP. 449	472	VECTOR ELECTR. 471
368	PEGASUS DATA SYS 510	402	RACET COMPUTES 366	437	STAR MICRONICS 348, 349	473	VECTOR ELECTR. 471
	PERCOM DATA 7, 307	403	RADGO SALES CO. 508	438	STATIC MEMORY SYS 391	474	VECTOR ELECTR. 471
369	PERIPHERALS UNLTD. 325	404	RADIO SHACK CIV	439	STRAWBERRY TREE COMP. 501	475	VECTOR ELECTR. 471
370	PERIPHIX INC. 436	405	RANA SYSTEMS 32, 33	440	STROBE 125	476	VECTOR ELECTR. 471
371	PERSONAL COMP.SYS 486	406	RCA 144	441	SUBLOGIC 150	477	VECTOR ELECTR. 471
372	PERSONAL SYS.TECHN. 427	407	RCE 326	442	SUNNY INT'L 573	478	VECTOR ELECTR. 471
	PHASE ONE SYS.INC. 251	408	RED BARON COMP.PROD. 316, 317	443	SUNTRONICS 408	514	VEYTEC INC. 530
373	PHONE I.INC. 70	409	RENAISSANCE TECHN. 347	528	SUNTRONICS 572	479	VICTOR BUSN.MACH. 89
374	PICKLES & TROUT 288	529	RICKER DATA 572	444	SUPERSOFT 167	480	VIDEX 17
508	PION INC. 519	410	ROSEN GRANDON ASSOC. 572	445	SUPERSOFT 169		VISICORP INC. 95
	POTOMAC MICRO-MAGIC 214	411	S C DIGITAL 480	446	SUPERSOFT 171	481	VISTA COMPUTER CO. 123
376	PRACTICAL PERIPH. 22, 23		S-100 INC 475	535	SYNERGETIC SOLUTIONS 539	502	VISUAL TECH 83
377	PRINCETON GRAPHIC SYS. 137	412	SAGE COMP. TECH. 47	447	SYSTEMED 566		VR DATA 227, 477
103	PRINTER BASE CO., THE 509	413	SATURN SYSTEMS INC. 99	448	SYSTEMS PLUS INC. 351	482	VYNET CORP. 477
378	PRIORITY ONE 596, 597	414	SAVVY MARKTG.INT'L. 119	449	TAB BOOKS 413	483	WASHINGTON COMP.SERV. 565
379	PRIORITY ONE 598, 599	415	SCIENTIFIC ENG. 566	450	TAB BOOKS 454	484	WEST STAR MICRO 523
380	PRIORITY ONE 600, 601	416	SCION CORP. 5	451	TARBELL ELECTR. 499	485	WESTERN ELECTRONICS 224
381	PRIORITY ONE 602, 603	417	SCOTIA SOFTWARE 489	452	TATUM LABS 407	486	WESTICO INC. 221
527	PRIORITY ONE 604		SCOTSDALE SYSTEMS 346	526	TECH DATA CORP. 562		WHITESMITHS LTD. 488
382	PROCESSOR INTERFACES INC. 568	418	SEATTLE COMP. PRODS. 277	453	TECMAR INC. 39	488	WILD HARE COMP.SYS. 423
384	PROMPT DOC CO., THE 193	419	SEATTLE COMP. PRODS. 334	454	TECMAR INC. 415	490	WINCHENDON GRP.,THE 407
	PROMPT DOC CO.,THE 311		SEIKOSHA CORP. 133		TEKTRONIX INC. 225, 406	481	WINTER CORP. 572
385	PROTECTO ENTERPR. 558	421	SEITZ TECH.PRODUCTS 562	456	TELECON SYSTEMS 558	482	WINTERHALTER & ASSOC. 469
386	PROTECTO ENTERPR. 568	422	SENECA ELECTRONICS 500	457	TELETEK 113	495	X COMP 199
387	PURCHASING AGENT,THE 50	423	SIERRA COMP.PROD. 504	458	TELEVIDEO INC 174, 175		XITEN SYSTEMS 431
388	QUADRAM CORP. 134, 135	424	SIERRA DATA SCIENCES 109	459	TERMINALS TERRIFIC 274	497	YORK 10 COMPUTERWARE 407
389	QUADRAM CORP. 421	426	SIGMATEK 572	460	TEXAS COMP.SYS. 401	498	ZYNAR LTD. 363
390	QUALITY SOFTWARE 445		SINCLAIR RESEARCH 200, 201, 305	461	TEXAS INSTRUMENTS 103		
524	QUANTECKNA 275		SINGER CO. 461	538	TEXAS INSTRUMENTS 289		
		427	SINGLE SOURCE SOLUTIONS 572	512	THREE M STATIC CONTROL 455		

\*Correspond directly with company.

## National Advertising Sales Representatives:

**Northeast (617) 444-3946**  
ME, NH, VT, MA, CT, RI, DE, MD, VA,  
WV, OK, TX, Upstate NY, Eastern  
Canada

Hajar Associates  
280 Hillside Ave.  
Needham Heights, MA 02194

**Mid Atlantic (201) 741-7744**  
NY, NYC, NJ, PA

Hajar Associates  
321 Broad St.  
Red Bank, NJ 07701

**Southeast (305) 628-3525**  
NC, SC, GA, FL, AL, MS, TN,  
KY, LA

Hajar Associates  
Diplomat Bldg.  
5400 Diplomat Circle  
Suite 205  
Orlando, FL 32810

**Midwest (312) 966-0160**  
MN, WI, MI, IA, IL, IN, OH,  
MO, NE, KS, ND, SD, AR

Hajar Associates  
5225 Old Orchard Rd.  
Suite 50  
Skokie, IL 60076

**Northwest (415) 964-0706**  
AK, HI, WA, OR, ID, MT, WY,  
Northern California, Nevada Except  
Las Vegas, Western Canada

Hajar Associates  
1000 Elwell Ct.  
Suite 124  
Palo Alto, CA 94303

**Southwest (714) 540-3554**  
UT, CO, AZ, NM, Las Vegas,  
Southern California

Hajar Associates  
3303 Harbor Blvd.  
Suite H-4A  
Costa Mesa, CA 92626

## European Advertising Sales Representatives:

Mr. Simon Smith  
McGraw-Hill Publishing Co.  
34 Dover St.  
London W1X 3RA  
England  
01 493 1451

Mr. Andrew Karnig  
Andrew Karnig & Associates  
Kungsholmsgatan 10  
112 27 Stockholm, Sweden  
08 51-68-70

Mr. Hans Csokor  
Publimedia  
Relsnerstrasse 61  
A-1037 Vienna, Austria

Mr. Fritz Krusebecker  
McGraw-Hill Publishing Co.  
Liebigstrasse 27C  
D-6000 Frankfurt/Main 1  
West Germany  
72-01-81

Mr. Michael Sales  
McGraw-Hill Publishing Co.  
17 rue Georges Bizet  
F 75116 Paris  
France  
720-33-42

Mr. Elio Gonzaga  
McGraw-Hill Publishing Co.  
Via Bracchini 1  
20123 Milan, Italy  
88-90-617

Mrs. Gurlt Gepner  
McGraw-Hill Publishing Co.  
115 Yosephthal St.  
Bat Yam, Israel  
866-561

Mrs. Maria Sarmiento  
Pedro Teixeira 8, Off. 320  
Iberia Mart I  
Madrid 4, Spain  
45-52-891

# BYTE READER SERVICE

SEPTEMBER 1982  
4192

For fastest service transfer mailer label from wrapper to coupon provided at the right. Requests cannot be honored unless zip code is given. This card valid for 90 days only. **NOTE**—If label is missing or defaced fill out coupon carefully—**PLEASE PRINT**—this is the only way to get requested material to you.

Name \_\_\_\_\_  
(Title) \_\_\_\_\_ (Company) \_\_\_\_\_  
Address \_\_\_\_\_  
City \_\_\_\_\_ State \_\_\_\_\_ Zip \_\_\_\_\_

1 21 41 61 81	101 121 141 161 181	201 221 241 261 281	301 321 341 361 381	401 421 441 461 481	501 521 541 561 581	601 621 641 661 681
2 22 42 62 82	102 122 142 162 182	202 222 242 262 282	302 322 342 362 382	402 422 442 462 482	502 522 542 562 582	602 622 642 662 682
3 23 43 63 83	103 123 143 163 183	203 223 243 263 283	303 323 343 363 383	403 423 443 463 483	503 523 543 563 583	603 623 643 663 683
4 24 44 64 84	104 124 144 164 184	204 224 244 264 284	304 324 344 364 384	404 424 444 464 484	504 524 544 564 584	604 624 644 664 684
5 25 45 65 85	105 125 145 165 185	205 225 245 265 285	305 325 345 365 385	405 425 445 465 485	505 525 545 565 585	605 625 645 665 685
6 26 46 66 86	106 126 146 166 186	206 226 246 266 286	306 326 346 366 386	406 426 446 466 486	506 526 546 566 586	606 626 646 666 686
7 27 47 67 87	107 127 147 167 187	207 227 247 267 287	307 327 347 367 387	407 427 447 467 487	507 527 547 567 587	607 627 647 667 687
8 28 48 68 88	108 128 148 168 188	208 228 248 268 288	308 328 348 368 388	408 428 448 468 488	508 528 548 568 588	608 628 648 668 688
9 29 49 69 89	109 129 149 169 189	209 229 249 269 289	309 329 349 369 389	409 429 449 469 489	509 529 549 569 589	609 629 649 669 689
10 30 50 70 90	110 130 150 170 190	210 230 250 270 290	310 330 350 370 390	410 430 450 470 490	510 530 550 570 590	610 630 650 670 690
11 31 51 71 91	111 131 151 171 191	211 231 251 271 291	311 331 351 371 391	411 431 451 471 491	511 531 551 571 591	611 631 651 671 691
12 32 52 72 92	112 132 152 172 192	212 232 252 272 292	312 332 352 372 392	412 432 452 472 492	512 532 552 572 592	612 632 652 672 692
13 33 53 73 93	113 133 153 173 193	213 233 253 273 293	313 333 353 373 393	413 433 453 473 493	513 533 553 573 593	613 633 653 673 693
14 34 54 74 94	114 134 154 174 194	214 234 254 274 294	314 334 354 374 394	414 434 454 474 494	514 534 554 574 594	614 634 654 674 694
15 35 55 75 95	115 135 155 175 195	215 235 255 275 295	315 335 355 375 395	415 435 455 475 495	515 535 555 575 595	615 635 655 675 695
16 36 56 76 96	116 136 156 176 196	216 236 256 276 296	316 336 356 376 396	416 436 456 476 496	516 536 556 576 596	616 636 656 676 696
17 37 57 77 97	117 137 157 177 197	217 237 257 277 297	317 337 357 377 397	417 437 457 477 497	517 537 557 577 597	617 637 657 677 697
18 38 58 78 98	118 138 158 178 198	218 238 258 278 298	318 338 358 378 398	418 438 458 478 498	518 538 558 578 598	618 638 658 678 698
19 39 59 79 99	119 139 159 179 199	219 239 259 279 299	319 339 359 379 399	419 439 459 479 499	519 539 559 579 599	619 639 659 679 699
20 40 60 80 100	120 140 160 180 200	220 240 260 280 300	320 340 360 380 400	420 440 460 480 500	520 540 560 580 600	620 640 660 680 700

**BYTE'S BOMB** is your direct line to the editor's desk. Each month, the authors of the two top-rated articles receive bonuses based on your evaluation. First look at the list of this month's articles and corresponding article numbers (located in the unclassified ads section on the page preceding the Reader Service list), then rate each article you've read as **Excellent, Good, Fair, or Poor**, based on your overall impression of the article, by circling the appropriate number in each column below. Your feedback helps to produce the best possible magazine each month.

Article No.	1	2	3	4	5	6	7	8	9	10	11	12	13	14	15	16	17	18	19	20	21	22	23	24	25
<b>Excellent</b>	801	805	809	813	817	821	825	829	833	837	841	845	849	853	857	861	865	869	873	877	881	885	889	893	897
<b>Good</b>	802	806	810	814	818	822	826	830	834	838	842	846	850	854	858	862	866	870	874	878	882	886	890	894	898
<b>Fair</b>	803	807	811	815	819	823	827	831	835	839	843	847	851	855	859	863	867	871	875	879	883	887	891	895	899
<b>Poor</b>	804	808	812	816	820	824	828	832	836	840	844	848	852	856	860	864	868	872	876	880	884	888	892	896	900

Comments \_\_\_\_\_

# BYTE READER SERVICE

SEPTEMBER 1982  
4192

For fastest service transfer mailer label from wrapper to coupon provided at the right. Requests cannot be honored unless zip code is given. This card valid for 90 days only. **NOTE**—If label is missing or defaced fill out coupon carefully—**PLEASE PRINT**—this is the only way to get requested material to you.

Name \_\_\_\_\_  
(Title) \_\_\_\_\_ (Company) \_\_\_\_\_  
Address \_\_\_\_\_  
City \_\_\_\_\_ State \_\_\_\_\_ Zip \_\_\_\_\_

1 21 41 61 81	101 121 141 161 181	201 221 241 261 281	301 321 341 361 381	401 421 441 461 481	501 521 541 561 581	601 621 641 661 681
2 22 42 62 82	102 122 142 162 182	202 222 242 262 282	302 322 342 362 382	402 422 442 462 482	502 522 542 562 582	602 622 642 662 682
3 23 43 63 83	103 123 143 163 183	203 223 243 263 283	303 323 343 363 383	403 423 443 463 483	503 523 543 563 583	603 623 643 663 683
4 24 44 64 84	104 124 144 164 184	204 224 244 264 284	304 324 344 364 384	404 424 444 464 484	504 524 544 564 584	604 624 644 664 684
5 25 45 65 85	105 125 145 165 185	205 225 245 265 285	305 325 345 365 385	405 425 445 465 485	505 525 545 565 585	605 625 645 665 685
6 26 46 66 86	106 126 146 166 186	206 226 246 266 286	306 326 346 366 386	406 426 446 466 486	506 526 546 566 586	606 626 646 666 686
7 27 47 67 87	107 127 147 167 187	207 227 247 267 287	307 327 347 367 387	407 427 447 467 487	507 527 547 567 587	607 627 647 667 687
8 28 48 68 88	108 128 148 168 188	208 228 248 268 288	308 328 348 368 388	408 428 448 468 488	508 528 548 568 588	608 628 648 668 688
9 29 49 69 89	109 129 149 169 189	209 229 249 269 289	309 329 349 369 389	409 429 449 469 489	509 529 549 569 589	609 629 649 669 689
10 30 50 70 90	110 130 150 170 190	210 230 250 270 290	310 330 350 370 390	410 430 450 470 490	510 530 550 570 590	610 630 650 670 690
11 31 51 71 91	111 131 151 171 191	211 231 251 271 291	311 331 351 371 391	411 431 451 471 491	511 531 551 571 591	611 631 651 671 691
12 32 52 72 92	112 132 152 172 192	212 232 252 272 292	312 332 352 372 392	412 432 452 472 492	512 532 552 572 592	612 632 652 672 692
13 33 53 73 93	113 133 153 173 193	213 233 253 273 293	313 333 353 373 393	413 433 453 473 493	513 533 553 573 593	613 633 653 673 693
14 34 54 74 94	114 134 154 174 194	214 234 254 274 294	314 334 354 374 394	414 434 454 474 494	514 534 554 574 594	614 634 654 674 694
15 35 55 75 95	115 135 155 175 195	215 235 255 275 295	315 335 355 375 395	415 435 455 475 495	515 535 555 575 595	615 635 655 675 695
16 36 56 76 96	116 136 156 176 196	216 236 256 276 296	316 336 356 376 396	416 436 456 476 496	516 536 556 576 596	616 636 656 676 696
17 37 57 77 97	117 137 157 177 197	217 237 257 277 297	317 337 357 377 397	417 437 457 477 497	517 537 557 577 597	617 637 657 677 697
18 38 58 78 98	118 138 158 178 198	218 238 258 278 298	318 338 358 378 398	418 438 458 478 498	518 538 558 578 598	618 638 658 678 698
19 39 59 79 99	119 139 159 179 199	219 239 259 279 299	319 339 359 379 399	419 439 459 479 499	519 539 559 579 599	619 639 659 679 699
20 40 60 80 100	120 140 160 180 200	220 240 260 280 300	320 340 360 380 400	420 440 460 480 500	520 540 560 580 600	620 640 660 680 700

To get further information on the products advertised in BYTE, fill out the reader service card with your name and address. Then circle the appropriate numbers for the advertisers you select from the list. Add a 20-cent stamp to the card, then drop it in the mail. Not only do you gain information, but our advertisers are encouraged to use the marketplace provided by BYTE. This helps us bring you a bigger BYTE. The index is provided as an additional service by the publisher, who assumes no liability for errors or omissions.

PLACE  
STAMP  
HERE

**BYTE**

READER SERVICE  
PO BOX 298  
DALTON, MA 01226  
USA

PLACE  
STAMP  
HERE

**BYTE**

READER SERVICE  
PO BOX 298  
DALTON, MA 01226  
USA

# BYTE

## SUBSCRIPTIONS

For a subscription to BYTE, please complete this card

Name \_\_\_\_\_

Address \_\_\_\_\_

City \_\_\_\_\_

State \_\_\_\_\_ Zip \_\_\_\_\_ Country \_\_\_\_\_

Card No. \_\_\_\_\_

Expiration date \_\_\_\_\_

Four digits above name—Master Charge only \_\_\_\_\_

Signature \_\_\_\_\_ Date \_\_\_\_\_

Please allow eight weeks for processing. Thank you.

USA

Canada  
Mexico

- 1 year  
 2 years  
 3 years

- \$19  
 \$34  
 \$49

- \$21  
 \$38  
 \$55

- \$43 Europe (air delivery) payment enclosed  
 \$35 Elsewhere (surface mail) payment enclosed

(Air mail rates available upon request)

**Please remit in US funds drawn on a US bank. Thank you.**

- Check enclosed (**Bonus** [North America only] one EXTRA issue—receive 13 issues for the price of 12)



- Bill me (North America only)

4192

# BYTE

## SUBSCRIPTIONS

For a subscription to BYTE, please complete this card

Name \_\_\_\_\_

Address \_\_\_\_\_

City \_\_\_\_\_

State \_\_\_\_\_ Zip \_\_\_\_\_ Country \_\_\_\_\_

Card No. \_\_\_\_\_

Expiration date \_\_\_\_\_

Four digits above name—Master Charge only \_\_\_\_\_

Signature \_\_\_\_\_ Date \_\_\_\_\_

Please allow eight weeks for processing. Thank you.

USA

Canada  
Mexico

- 1 year  
 2 years  
 3 years

- \$19  
 \$34  
 \$49

- \$21  
 \$38  
 \$55

- \$43 Europe (air delivery) payment enclosed  
 \$35 Elsewhere (surface mail) payment enclosed

(Air mail rates available upon request)

**Please remit in US funds drawn on a US bank. Thank you.**

- Check enclosed (**Bonus** [North America only] one EXTRA issue—receive 13 issues for the price of 12)



- Bill me (North America only)

4192

*Note our special offer!  
 Send cash with your order  
 and receive 13 issues  
 for the price of 12 for  
 each year you subscribe.  
 (North America only, please.)*

# Don't Miss An Issue!

## Have BYTE delivered to your door.

Each month BYTE will bring you the latest in microcomputer technology.

DISCOVER and IMPLEMENT new ideas. Don't miss the original information presented in the pages of BYTE.

With BYTE you'll always be among the first to know about the important breakthroughs, worthwhile new equipment, and innovative projects in the world of computing.

CHALLENGE US to deliver the very best ideas in microcomputers and advanced technology to you. Return the attached card today!

Subscribe to BYTE—the world's leading computer magazine.

PLACE  
STAMP  
HERE

**BYTE** SUBSCRIPTIONS  
PO Box 590  
Martinsville NJ 08836  
USA

PLACE  
STAMP  
HERE

**BYTE** SUBSCRIPTIONS  
PO Box 590  
Martinsville NJ 08836  
USA

# THE LEADING EDGE IN PRINTERS

ONE GREAT LINE. ONE GREAT WARRANTY.

Finally, there's one full family of printers that covers every business or word processing application—all from C. Itoh, a company known for packing more product into less price, and all distributed exclusively by Leading Edge, a company known for searching out and providing that very thing. Which means that one call to one source can get you any printer, any time you need it, for any purpose. All backed by a full years' warranty from Leading Edge. (Try *that* on any other line of printers.)

## THE PRO'S.

**The Prowriters: business printers—and more.** The "more" is a dot-matrix process with more dots. It gives you denser, correspondence quality copy (as opposed to business quality copy, which looks like a bad job of spray-painting).

**Prowriter:** 120 cps. 80 columns dot matrix compressable to 136. 10" carriage. Parallel or serial interface.

**Prowriter 2:** Same as Prowriter, except 15" carriage allows full 136 columns in normal print mode. Parallel or serial interface.



## THE STAR.

**The Starwriter F-10.** In short (or more precisely, in a sleek 6" high, 30-pound unit), it gives you more of just about everything—except bulk and noise—than any other printer in its price range. It's a 40 cps letter-quality daisy-wheel with a bunch of built-in functions to simplify and speed up word processing. It plugs into almost any micro on the market, serial or parallel.



## THE MASTER.

**The Printmaster F-10.** Does all the same good stuff as the Starwriter except, at 55 cps, the Master does it faster.



Distributed Exclusively by Leading Edge Products, Inc., 225 Turnpike Street, Canton, Massachusetts 02021.  
Call: toll-free 1-800-343-6833; or in Massachusetts call collect (617) 828-8150. Telex 951-624.

# Three Outstanding and Affordable Modems Available for You . . . Only at Radio Shack!

Auto-Dial, Auto-Answer  
Direct-Connect Modem II  
**249<sup>00</sup>**



Telephone Interface II  
**199<sup>00</sup>**



Direct-Connect Modem I  
**149<sup>00</sup>**



## You'll Want to See Our Complete Line Of Data Communications Accessories

**Direct-Connect Modem II.** Designed and built by Radio Shack. Fully programmable! Built-in 6805 microprocessor uses a 25-character register to store commands and parameters for automatic dial-up using tone and/or pulse train, programmed pauses, operational mode changes, and more. With appropriate software, it can even operate unattended for late night, low-cost access to your data base. Features Bell 103J compatible, 300 baud operation with both local and loop-back testing. Connects directly with modular phone jack. (26-1173)

**Direct-Connect Modem I.** Our lowest priced full-duplex modem. 300 baud, Bell 103J compatible answer/originate modes. For simplex operation without RS-232C board in 16K Model I computers, just add optional software and cable. For modular phone jacks. (26-1172)

**Telephone Interface II.** Really easy to use! Just dial the desired phone number, place the telephone handset on the interface and you're ready to transfer data and programs anywhere in America! 300 baud originate/answer operation. Full or half-duplex. (26-1171)

**TRS-80<sup>®</sup> Accessories.** Our null-modem extender allows two computers to communicate without a modem. Use with our 10', 25', 50', or 100' cables—expand even further with cable extenders.



**Get "On Line" Today!** Visit your nearby Radio Shack Computer Center, store or participating dealer—we're your datacomm headquarters!

**Radio Shack<sup>®</sup>**  
The biggest name in little computers™  
A DIVISION OF TANDY CORPORATION

Circle 404 on inquiry card.

Send me a free TRS-80 Computer Catalog.

Mail To: Radio Shack, Dept. 83-A-156  
300 One Tandy Center, Fort Worth, Texas 76102

NAME \_\_\_\_\_

ADDRESS \_\_\_\_\_

CITY \_\_\_\_\_ STATE \_\_\_\_\_ ZIP \_\_\_\_\_

Retail prices may vary at individual stores and dealers. TRS-80 modems are FCC registered. Multi-line use requires modification or an adapter.